



Project Manual

for the

Liberty High School Stadium Improvements

BID SET NOT FOR CONSTRUCTION

December 21, 2018

DSA File Number: 7-H4
DSA Application Number: 01-117742
PTN Number: 61721-0066
Bid Number: U1809L

Owner:
Liberty Union High School District
850 2nd Street
Brentwood, California 95402

Architect:
Quattrocchi Kwok Architects
636 Fifth Street
Santa Rosa, CA 95404
P: 707.576.0829
F: 707.576.0295

Architect's Project No.: 1722.00

DOCUMENT 00 0107

PROFESSIONAL SEALS AND DSA IDENTIFICATION STAMP

DIVISION OF THE STATE ARCHITECT IDENTIFICATION STAMP

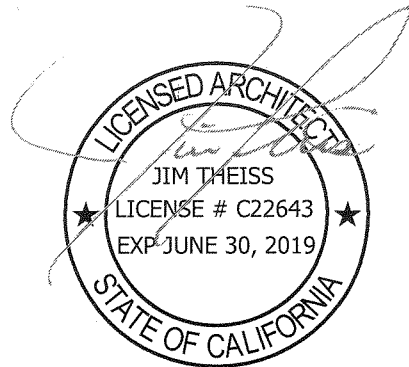

Date: 08/31/2018

Architect

QUATTROCCHI KWOK ARCHITECTS

636 Fifth Street
Santa Rosa, CA 95404
P: 707-576-0829
Jim Theiss
Lic: C22643



Civil Engineer

CARLSON BARBEE & GIBSON

2633 Camino Ramon, Ste. 350
San Ramon, CA 94583
P: 925-866-0322
Jason Vogan
Lic: 59299

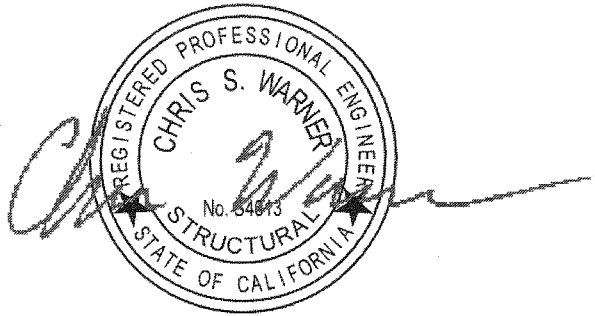

Structural Engineer
ZFA
1212 Fourth Street, Suite Z
Santa Rosa, CA 95404
P: 707-526-0992
Chris Warner
Lic: S4613

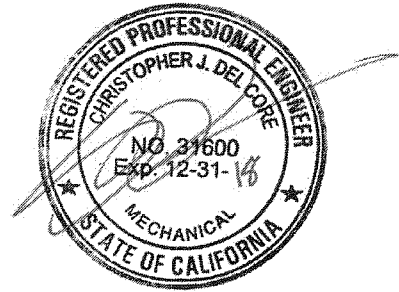

Mechanical Engineer
COSTA ENGINEERS
3274 Villa Lane
Napa, Ca. 94558
P: 707-252-9177
Chris DelCore
Lic: M31600

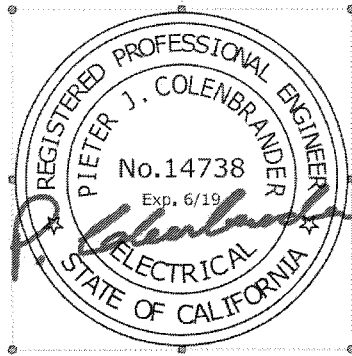

Electrical Engineer
O'MAHONY & MYER
4340 Redwood Hwy., Suite 245
San Rafael, CA 94903
P: 415-492-0420
Pieter Colenbrander
Lic: E14738



Landscape Architect
GSM LANDSCAPE ARCHITECTS, INC
1700 Soscol Avenue, Suite 23
Napa, CA 94559
P: 707-255-4630
Gretchen Stranzl McCann
Lic: 2790

END OF SECTION

DOCUMENT 00 0110

TABLE OF CONTENTS

00 0101 - COVER
00 0107 - PROFESSIONAL SEALS AND DSA IDENTIFICATION STAMP
00 0110 - TABLE OF CONTENTS
00 0115 - LIST OF DRAWINGS
00 3100 - INFORMATION AVAILABLE TO BIDDERS

DIVISION 00 PROCUREMENT AND CONTRACTING REQUIREMENTS

LIBERTY UNION HIGH SCHOOL BIDDING DOCUMENTS FOR STADIUM IMPROVEMENTS AT
LIBERTY HIGH SCHOOL
00 7300 - SUPPLEMENTAL GENERAL CONDITIONS

TECHNICAL SPECIFICATIONS

DIVISION 01 - GENERAL REQUIREMENTS

01 2600 - MODIFICATION PROCEDURES
01 3300 - SUBMITTALS
01 3546 -CONSTRUCTION INDOOR AIR QUALITY PLAN
01 3900 - COORDINATION AND MEETINGS
01 4000 - QUALITY CONTROL
01 4200 - REFERENCE STANDARDS
01 4523 - TESTING AND INSPECTION SERVICES
01 5000 - TEMPORARY FACILITIES
01 5600 - TEMPORARY CONTROLS
01 6000 - PRODUCT REQUIREMENTS
01 6116 - VOLITILE ORGANIC COMPOUND RESTRICTIONS
01 6116.01 - ACCESSORY MATERIAL VOC CONTENT CERTIFICATION FORM
01 7419 - CONSTRUCTION WASTE MANAGEMENT
01 7500 - STARTING OF SYSTEMS
01 7513 -EXECUTION REQUIREMENTS
01 8113 -SUSTAINABLE DESIGN REQUIREMENTS

DIVISION 02 - EXISTING CONDITIONS

02 4116 -BUILDING DEMOLITION

DIVISION 03 - CONCRETE

03 1000 -CONCRETE FORMING AND ACCESSORIES
03 2000 -CONCRETE REINFORCING
03 3000 -CAST-IN-PLACE CONCRETE
03 3511 -CONCRETE FLOOR FINISHES

DIVISION 04 - MASONRY

NOT USED

DIVISION 05 - METALS

05 1200 -STRUCTURAL STEEL FRAMING
05 3000 - METAL DECKING
05 5000 -METAL FABRICATIONS

DIVISION 06 - WOOD, PLASTICS AND COMPOSITES

06 1000 -ROUGH CARPENTRY
06 1733 -WOOD I-JOISTS
06 1800 -GLUED LAMINATED CONSTRUCTION
06 2000 -FINISHED CARPENTRY
06 4100 -ARCHITECTURAL WOOD CASEWORK

DIVISION 07 - THERMAL AND MOISTURE PROTECTION

07 1113 -BITUMINOUS DAMPPROOFING
07 2100 -BOARD AND BATT [BUILDING] INSULATION
07 2129 -SPRAYED INSULATION
07 2500 -WEATHER BARRIERS
07 2633 -WATER VAPOR EMISSION CONTROL
07 4113 -METAL ROOF PANELS
07 5200 -MODIFIED BITUMINOUS MEMBRANE ROOFING
07 6200 -SHEET METAL FLASHING AND TRIM
07 7100 -ROOF SPECIALTIES
07 8400 -FIRE STOPPING
07 9200 -JOINT SEALERS
07 9513 -EXPANSION JOINTS COVER ASSEMBLIES

DIVISION 08 - OPENINGS

08 1113 - HOLLOW METAL DOORS AND FRAMES
08 3100 - ACCESS DOORS AND PANELS
08 3323 - OVERHEAD COILING DOORS
08 4313 - ALUMINUM ENTRANCES AND STOREFRONTS
08 5600 - SPECIAL WINDOWS
08 6200 - UNIT SKYLIGHTS
08 7100 -DOOR HARDWARE
DOOR HARDWARE MANUFACTURER CUT SHEETS
08 8000 -GLAZING
08 8300 -MIRRORS
08 9100 - LOUVERS

DIVISION 09 - FINISHES

09 0511 -CONCRETE FLOOR PREPARATION
09 0512 -CONCRETE FLOOR MOISTURE CONTENT AND PH TESTING
09 2116 -GYPSUM BOARD ASSEMBLIES

09 2513 -ACRYLIC-MODIFIED PORTLAND CEMENT PLASTER
09 3000 -TILING
09 6500 -RESILIENT FLOORING
09 6566 -RESILIENT ATHLETIC FLOORING
09 6700 -FLUID-APPLIED FLOORING
09 7723 -WALL PANELS
09 9113 -EXTERIOR PAINTING
09 9123 -INTERIOR PAINTING
09 9623 -ANTI-GRAFFITI COATINGS

DIVISION 10 - SPECIALTIES

10 0610 -EXTERIOR SIGNAGE
10 1101 -VISUAL DISPLAY BOARDS
10 1400 -SIGNAGE
10 2113 -REINFORCED COMPOSITE TOILET COMPARTMENTS
10 2800 -TOILET ACCESSORIES
10 4400 -FIRE PROTECTION SPECIALTIES

DIVISION 11 - EQUIPMENT

11 4000 -FOODSERVICE EQUIPMENT
11 5200 -AUDIO-VISUAL EQUIPMENT

DIVISION 12 - FURNISHINGS

12 3600 -COUNTERTOPS

DIVISION 13 - SPECIAL CONSTRUCTION

13 3430 -PRE-ENGINEERED GRANDSTAND AND PRESS BOX
13 4713 -CATHODIC PROTECTION SYSTEM

DIVISION 14 THROUGH DIVISION 20

NOT USED

DIVISION 21 - FIRE SUPPRESSION

21 0000 - FIRE PROTECTION GENERAL
21 0500 - OVERHEAD FIRE PROTECTION SYSTEM
21 1000 - UNDERGROUND FIRE SERVICE

DIVISION 22 - PLUMBING

22 0000 -PLUMBING
PLUMBING FIXTURE MANUFACTURER CUT SHEETS
22 1100 -SITE WATER DISTRIBUTION

DIVISION 23 - HEATING VENTILATING AND AIR CONDITIONING (HVAC)

23 0000 -HEATING, VENTILATING, AIR CONDITIONING

23 0500 -GENERAL MECHANICAL
23 0593 -TESTING, ADJUSTING, AND BALANCING FOR HVAC
23 0923 -ENERGY MANAGEMENT SYSTEM FOR HVAC (EMS)

DIVISION 25 - INTEGRATED AUTOMATION

NOT USED

DIVISION 26 - ELECTRICAL

26 0500 -BASIC ELECTRICAL REQUIREMENTS
26 0800 -TESTING
26 2400 -SERVICE & DISTRIBUTION SYSTEM
26 2700 -BASIC ELECTRICAL MATERIALS AND METHODS
26 5101 -LIGHTING
26 5601 -SITE LIGHTING
26 5700 -LOW VOLTAGE LIGHTING CONTROL SYSTEM

DIVISION 27 - COMMUNICATIONS

27 0000 - TELECOMMUNICATIONS SYSTEM

DIVISION 28 - ELECTRONIC SAFETY AND SECURITY

28 3100 -FIRE ALARM SYSTEM - VOICE EVAC
-FIRE ALARM CUT SHEETS

DIVISION 31- EARTHWORK

31 1000 -SITE CLEARING
31 2000 -EARTHWORK
31 2313 -SUBGRADE PREPERATION & BASE MATERIAL
31 2333 -TRENCHING AND BACKFILL

DIVISION 32- EXTERIOR IMPROVEMENTS

32 1216 -ASPHALT CONCRETE PAVING
32 1313 - CONCRETE PAVING
32 1723 -PAVEMENT MARKING
32 3113 -CHAIN LINK FENCES AND GATES
32 3119 -ORNAMENTAL STEEL FENCES AND GATES
32 3121 -DOUBLE HEAVY-DUTY SWING GATE
32 8000 -IRRIGATION SYSTEM
32 9000 -LANDSCAPE PLANTING

DIVISION 33 - UTILITIES

33 3100 - SITE SANITARY SEWERAGE
33 4000 -SITE STORM DRAINAGE

DIVISIONS 34 THROUGH 48

NOT USED

END OF TABLE OF CONTENTS

DOCUMENT 00 0115 - LIST OF DRAWINGS

VOLUME 1

GENERAL

- G-0.1 COVER SHEET
- G-0.2 ABBREVIATIONS AND NOTES
- G-0.2.1 SHEET INDEX
- G-0.3 FIRE DEPARTMENT APPROVAL PLAN
- G-0.4 ACCESS AND CODE COMPLIANCE PLAN
- G-0.5 CODE ANALYSIS PLAN

CIVIL

- C-1.0 EXISTING CONDITIONS / DEMOLITION
- C-2.1 HORIZONTAL CONTROL
- C-2.2 HORIZONTAL CONTROL
- C-3.1 UTILITY PLAN
- C-3.2 UTILITY PLAN
- C-4.1 GRADING AND DRAINAGE
- C-4.2 GRADING AND DRAINAGE
- C-5.0 DETAILS
- C-6.0 STORMWATER CONTROL PLAN
- C-7.0 STRIPING AND SLURRY SEAL LIMITS
- C-8.0 EROSION CONTROL PLAN
- C-9.0 NORTH AREA

LANDSCAPE

- L1.0 MATERIAL AND DETAIL REFERENCE PLAN
- L1.1 MATERIAL AND DETAIL REFERENCE PLAN
- L1.2 CONSTRUCTION DETAILS
- L1.3 CONSTRUCTION DETAILS
- L1.4 CONSTRUCTION DETAILS
- L2.0 LAYOUT PLAN
- L2.1 LAYOUT PLAN
- L3.0 IRRIGATION PLAN
- L3.1 IRRIGATION PLAN
- L3.2 IRRIGATION LEGEND
- L3.3 IRRIGATION NOTES & SCHEDULES
- L3.4 IRRIGATION DETAILS
- L3.5 IRRIGATION DETAILS
- L3.6 IRRIGATION DETAILS
- L3.7 IRRIGATION DETAILS
- L3.8 IRRIGATION DETAILS
- L4.0 PLANTING PLAN
- L4.1 PLANTING PLAN

ARCHITECTURAL

A-1.1 SITE AND EGRESS PLAN

BUILDING A - CONCESSIONS BUILDING

- A-A2.1 BLDG A FLOOR PLAN
- A-A3.1 BLDG A REFLECTED CEILING PLAN
- A-A4.1 BLDG A ROOF PLAN
- A-A5.1 BLDG A EXTERIOR ELEVATIONS
- A-A6.1 BLDG A SECTIONS
- A-A6.2 BLDG A WALL SECTIONS
- A-A6.3 BLDG A WALL SECTIONS
- A-A7.1 BLDG A INTERIOR ELEVATIONS
- A-A7.2 BLDG A INTERIOR ELEVATIONS
- A-A7.3 BLDG A INTERIOR ELEVATIONS

BUILDING B - FITNESS BUILDING

- A-B2.1 BLDG B FLOOR PLAN
 - A-B3.1 BLDG B REFLECTED CEILING PLAN
 - A-B4.1 BLDG B ROOF PLAN
 - A-B5.1 BLDG B EXTERIOR ELEVATIONS
 - A-B6.1 BLDG B SECTIONS
 - A-B6.2 BLDG B WALL SECTIONS
 - A-B7.1 BLDG B INTERIOR ELEVATIONS
 - A-B7.2 BLDG B INTERIOR ELEVATIONS
 - A-B7.3 BLDG B INTERIOR ELEVATIONS
- A-8.1 DOOR & WINDOW SCHEDULE
- A-9.1 WALL DETAILS
- A-9.2 ROOFING DETAILS -BUR
- A-9.3 ROOFING DETAILS -PERFORMED METAL
- A-9.4 ROOFING DETAILS -RAIN CANOPY
- A-9.5 OPENING DETAILS
- A-9.6 EXTERIOR DETAILS
- A-10.1 CEILING DETAILS
- A-10.2 INTERIOR DETAILS
- A-10.3 BLDGS A & B SIGNAGE PLANS & DETAILS

STRUCTURAL

- S-0.1 GENERAL NOTES
- S-1.1 TYPICAL CONCRETE DETAILS
- S-1.2 TYPICAL WOOD DETAILS
- S-1.3 TYPICAL WOOD DETAILS
- S-A2.1 CONCESSION BLDG FDN & ROOF PLAN
- S-B2.1 FITNESS BLDG FDN & ROOF PLAN
- S-4.1 FOUNDATION DETAILS

- S-6.1 FRAMING DETAILS
- S-7.1 RAIN CANOPY DETAILS

MECHANICAL

- M-1.1 MECHANICAL SCHEDULES & LEGENDS
- M-2.1 BLDG A AND BLDG B MECHANICAL FLOOR PLANS
- M-3.1 BLDG A AND BLDG B ROOF PLAN
- M-4.1 MECHANICAL DETAILS
- M-5.1 CONTROL DIAGRAMS
- M-5.2 CONTROL DIAGRAMS

PLUMBING

- P-1.1 PLUMBING SCHEDULES & LEGENDS
- P-2.1 BLDG A PLUMBING FLOOR PLANS
- P-2.2 BLDG B PLUMBING FLOOR PLANS
- P-3.1 BLDG A CONCESSIONS ENLARGED PLUMBING PLANS
- P-3.2 STADIUM TOILETS ENLARGED PLUMBING PLANS
- P-3.3 BLDG B FITNESS ENLARGED PLUMBING PLANS
- P-4.1 BLDG B PLUMBING ROOF PLAN
- P-5.1 PLUMBING DETAILS

ELECTRICAL

- E-0.1 SYMBOLS LIST, GENERAL NOTES & LIST OF DRAWINGS
- E-1.1 SITE PLAN - ELECTRICAL
- E-A2.1 CONCESSION BUILDING FLOOR PLAN - LIGHTING & LUMINAIRE SCH.
- E-B2.1 FITNESS BUILDING FLOOR PLAN - LIGHTING
- E-A3.1 CONCESSION BUILDING FLOOR PLAN - ELECTRICAL
- E-B3.1 FITNESS BUILDING FLOOR PLAN - ELECTRICAL
- E-5.1 SINGLE LINE DIAGRAMS
- E-5.2 LIGHTING DETAILS
- E-6.1 SCHEDULES
- E-6.2 SCHEDULES
- E-7.1 DETAILS DIAGRAM
- E-8.1 TITLE- 24 DOCUMENTATION
- E-8.2 TITLE- 24 DOCUMENTATION

FIRE ALARM

- FE-0.1 FIRE ALARM EQUIPMENT LIST & NOTES
- FE-1.1 SITE PALAN - FIRE ALARM
- FE-A3.1 CONCESSION BUILDING & PORTABLE RESTROOMS FLOOR PLANS - FIRE ALARM
- FE-B3.1 FITNESS BUILDING FLOOR PLAN - FIRE ALARM
- FE-5.1 FIRE ALARM RISER DIAGRAM
- FE-6.1 FIRE ALARM CALCULATIONS

FIRE PROTECTION

- FP-0.1 LEGEND, NOTES AND DETAILS - FIRE PROTECTION

| | |
|---------|---|
| FP-1.1 | SITE PLAN FIRE PROTECTION |
| FP-B2.1 | BUILDING B PIPING PLAN - FIRE PROTECTION |
| FP-B3.1 | BUILDING B CEILING PLAN - FIRE PROTECTION |
| FP-6.1 | DETAILS - FIRE PROTECTION |
| FP-6.2 | DETAILS AND SEISMIC BRACING CALCS - FIRE PROTECTION |

CATHODIC PROTECTION

| | |
|--------|------------|
| CP-1.2 | CP DETAILS |
| CP-1.3 | CP DETAILS |

FOODSERVICE

| | |
|------|---|
| K1.0 | FOODSERVICE EQUIPMENT FLOOR PLAN |
| K2.0 | FOODSERVICE EQUIPMENT ELECTRICAL PLAN |
| K3.0 | FOODSERVICE EQUIPMENT PLUMBING PLAN |
| K4.0 | FOODSERVICE EQUIPMENT BUILDING CONDITIONS |
| K5.0 | FOODSERVICE EQUIPMENT ELEVATIONS |
| K6.0 | FOODSERVICE EQUIPMENT ANCHORAGE DETAILS |

TITLE 24 COMPLIANCE DOCUMENTATION

| | |
|-----|-------------------|
| T-1 | TITLE 24 - BLDG A |
| T-2 | TITLE 24 - BLDG A |
| T-3 | TITLE 24 - BLDG A |
| T-4 | TITLE 24 - BLDG B |
| T-5 | TITLE 24 - BLDG B |

VOLUME 2

GENERAL

| | |
|---------|-------------|
| G-0.1 | COVER SHEET |
| G-0.2.1 | SHEET INDEX |

BLEACHER

| | |
|-------|--------------------------------|
| 1/29 | COVER |
| 2/29 | GENERAL NOTES |
| 3/29 | FOOTING LAYOUT |
| 4/29 | FOOTING DETAILS |
| 5/29 | RAMP FOOTING LAYOUT |
| 6/29 | UNDERSTRUCTURE LAYOUT |
| 7/29 | UNDERSTRUCTURE STRINGER LAYOUT |
| 8/29 | RAMP UNDERSTRUCTURE LAYOUT |
| 9/29 | SECTION VIEW |
| 10/29 | SECTION VIEW |
| 11/29 | SECTION VIEW @ PRESSBOX |
| 12/29 | SIGHT LINES |
| 13/29 | SEATING LAYOUT |
| 14/29 | SEAT BRACKET LAYOUT |

| | |
|-------|-------------------|
| 15/29 | EXIT RAMPS |
| 16/29 | EXIT STAIRS |
| 17/29 | EXIT DETAILS |
| 18/29 | EXIT DETAILS |
| 19/29 | EXIT DETAILS |
| 20/29 | EXIT DETAILS |
| 21/29 | PRESS BOX |
| 22/29 | PRESS BOX |
| 23/29 | PRESS BOX DETAILS |
| 24/29 | PRESS BOX DETAILS |
| 25/29 | PRESS BOX DETAILS |
| 26/29 | CEILING DETAIL |
| 27/29 | PLANK DETAILS |
| 28/29 | DETAILS |
| 29/29 | DETAILS |

PORTABLE TOILET BUILDING

ARCHITECTURAL

| | |
|-------------------|--|
| A-0 | COVER SHEET |
| A-0A | T & I FORMS |
| A-0.0 | BUILDING OPTIONS SCHEDULE |
| A-0.1 | SYMBOLS LEGEND, ABBREVIATION, AND ADA SIGNAGE |
| A-0.2 | SCHEDULES |
| A-0.5A | ENERGY COMPLIANCE FORMS |
| A-0.5B | ENERGY CALC'S PRF FORMS ZONE 14 WORST CASE (MODEL E) |
| A-0.5C | ENERGY CALC'S PRF FORMS ZONE 15 WORST CASE (MODEL E) |
| A-0.5D | ENERGY CALC'S PRF FORMS ZONE 16 WORST CASE (MODEL E) |
| A-0.6A | CERTIFICATE OF COMPLIANCE FORMS |
| A-0.6B | CERTIFICATE OF COMPLIANCE FORMS |
| A-0.7 | DESIGN ENERGY VALUES BY ZONE & GREEN SPECIFICATIONS |
| A-1.01 | FLOOR PLAN - "MODEL A-1" OR "MODEL A-2" |
| A-1.02 | FLOOR PLAN - "MODEL B-1" OR "MODEL B-2" |
| A-1.03 | FLOOR PLAN - "MODEL C-1" OR "MODEL C-2" |
| A-1.04 | FLOOR PLAN - "MODEL D-1" OR "MODEL E" |
| A-2.01 | REFLECTED CEILING PLAN - "MODEL A-1" OR "MODEL A-2" |
| A-2.02 | REFLECTED CEILING PLAN - "MODEL B-1" OR "MODEL B-2" |
| A-2.03 | REFLECTED CEILING PLAN - "MODEL C-1" OR "MODEL C-2" |
| A-2.04 | REFLECTED CEILING PLAN - "MODEL D-1" OR "MODEL E" |
| A-2.20 | CEILING DETAILS - T-GRID |
| A-2.21 | CEILING DETAILS - HARBUR |

| | |
|-------------------|---|
| A-3.01 | ROOF PLAN - 0.018" METAL DECK- MONO OR DUAL SLOPE |
| A-3.11 | ROOF PLAN - 0.009" METAL DECK- MONO OR DUAL SLOPE |
| A-3.01 | ROOF PLAN - TPO - MONO OR DUAL SLOPE - PARAPET |
| A-3.11 | ROOF PLAN - TPO ROOF - MONO OR DUAL SLOPE |
| A-3.50 | ROOF DETAILS - 0.018" METAL DECK |
| A-3.01 | ROOF DETAILS - 0.009" METAL DECK |
| A-3.01 | ROOF DETAILS - 0.009" METAL DECK |
| A-3.01 | ROOF DETAILS - PARAPET DETAIL |
| A-3.01 | ROOF DETAILS - TPO ROOF |
| A-4.01 | EXTERIOR ELEVATIONS - "MODEL A-1" - MONO OR DUAL SLOPE |
| A-4.11 | EXTERIOR ELEVATIONS - "MODEL A-1" - MONO OR DUAL SLOPE / PARAPET |
| A-4.02 | EXTERIOR ELEVATIONS - "MODEL A-2" - MONO OR DUAL SLOPE |
| A-4.12 | EXTERIOR ELEVATIONS - "MODEL A-2" - MONO OR DUAL SLOPE / PARAPET |
| A-4.03 | EXTERIOR ELEVATIONS - "MODEL B-1" - MONO OR DUAL SLOPE |
| A-4.13 | EXTERIOR ELEVATIONS - "MODEL B-1" - MONO OR DUAL SLOPE / PARAPET |
| A-4.04 | EXTERIOR ELEVATIONS - "MODEL B-2" - MONO OR DUAL SLOPE |
| A-4.14 | EXTERIOR ELEVATIONS - "MODEL B-2" - MONO OR DUAL SLOPE / PARAPET |
| A-4.05 | EXTERIOR ELEVATIONS - "MODEL C-1" - MONO OR DUAL SLOPE |
| A-4.15 | EXTERIOR ELEVATIONS - "MODEL C-1" - MONO OR DUAL SLOPE / PARAPET |
| A-4.06 | EXTERIOR ELEVATIONS - "MODEL C-2" - MONO OR DUAL SLOPE |
| A-4.16 | EXTERIOR ELEVATIONS - "MODEL C-2" - MONO OR DUAL SLOPE / PARAPET |
| A-4.07 | EXTERIOR ELEVATIONS - "MODEL D-1" - MONO OR DUAL SLOPE |
| A-4.17 | EXTERIOR ELEVATIONS - "MODEL D-1" - MONO OR DUAL SLOPE / PARAPET |
| A-4.08 | EXTERIOR ELEVATIONS - "MODEL E" - MONO OR DUAL SLOPE |
| A-4.18 | EXTERIOR ELEVATIONS - "MODEL E" - MONO OR DUAL SLOPE / PARAPET |
| A-5.01 | CROSS SECTION - MONO SLOPE - 0.018" OR BUILT UP ROOF DECK |
| A-5.02 | CROSS SECTION - DUAL SLOPE - 0.018" OR BUILT UP ROOF DECK |
| A-5.03 | CROSS SECTION - MONO SLOPE - 0.009" ROOF DECK |
| A-5.04 | CROSS SECTION - DUAL SLOPE - 0.009" ROOF DECK |
| A-5.05 | CROSS SECTION |
| A-5.50 | ARCHITECTURAL DETAILS - WOOD STUD - WOOD SIDING |
| A-5.51 | ARCHITECTURAL DETAILS - WOOD STUD - PLASTER |
| A-5.52 | ARCHITECTURAL DETAILS - WOOD STUD - WOOD SIDING - 1 HOUR RATED |
| A-5.53 | ARCHITECTURAL DETAILS - WOOD STUD - PLASTER - 1 HOUR RATED |
| A-5.50 | ARCHITECTURAL DETAILS - STEEL STUD - WOOD SIDING |
| A-5.51 | ARCHITECTURAL DETAILS - STEEL STUD - PLASTER |
| A-5.52 | ARCHITECTURAL DETAILS - STEEL STUD - WOOD SIDING - 1 HOUR RATED |
| A-5.53 | ARCHITECTURAL DETAILS - STEEL STUD - PLASTER - 1 HOUR RATED |
| A-5.54 | ARCHITECTURAL DETAILS - 1 HOUR RATED OPTIONS |

| | |
|-------------------|--|
| A-5.70 | ARCHITECTURAL DETAILS - FLOOR |
| A-5.80 | ARCHITECTURAL DETAILS - MISCELLANEOUS/OPTIONS |
| A-5.81 | ARCHITECTURAL DETAILS - MISCELLANEOUS/OPTIONS |

| | |
|-------------------|--|
| A-6.01 | INTERIOR ELEVATIONS - WALL MOUNTED |
| A-6.02 | INTERIOR ELEVATIONS - FLOOR MOUNTED |

FOUNDATION

| | |
|-------------------|---|
| F-0.01 | WOOD FOUNDATION PLAN - 12' x 10' (50 PSF) |
| F-0.02 | WOOD FOUNDATION PLAN - 12' x 40' (50+15 PSF) |
| F-0.03 | WOOD FOUNDATION PLAN - 12' x 10' (100 PSF) |
| F-0.04 | WOOD FOUNDATION PLAN - 12' x 10' (150 PSF) |
| F-0.50 | FOUNDATION DETAILS - WOOD |

| | |
|-------------------|--|
| F-1.01 | CONCRETE FOUNDATION PLAN - ABOVE GRADE - WOOD FLOOR |
| F-1.11 | CONCRETE FOUNDATION PLAN - ABOVE GRADE - CONCRETE FLOOR |
| F-1.50 | CONCRETE FOUNDATION DETAILS - ABOVE GRADE |

| | |
|-------------------|--|
| F-2.01 | CONCRETE FOUNDATION PLAN - BELOW GRADE - WOOD FLOOR |
| F-2.11 | CONCRETE FOUNDATION PLAN - BELOW GRADE - CONCRETE FLOOR |
| F-2.50 | CONCRETE FOUNDATION DETAILS - BELOW GRADE |
| F-2.51 | FOUNDATION DETAILS - CONCRETE |

STRUCTURAL

| | |
|-------------------|---|
| S-0.1 | STRUCTURAL SPECIFICATIONS |
| S-1.01 | FLOOR FRAMING PLAN - WOOD FLOOR |
| S-1.11 | FLOOR FRAMING PLAN - CONCRETE FLOOR |
| S-1.50 | FLOOR FRAMING DETAILS - WOOD FLOOR |
| S-1.50 | FLOOR FRAMING DETAILS - CONCRETE FLOOR |

| | |
|-------------------|---|
| S-2.01 | ROOF FRAMING PLAN - 0.010", BUILT UP, OR TPO ROOF - MONO SLOPE |
| S-2.02 | ROOF FRAMING PLAN - 0.008" - MONO SLOPE |

| | |
|-------------------|---|
| S-2.11 | ROOF FRAMING PLAN - 0.018", BUILT UP, OR TPO ROOF - DUAL SLOPE |
| S-2.40 | ROOF FRAMING PLAN - 0.008" - DUAL SLOPE |
| S-2.40 | ROOF FRAMING PLAN - DUAL / MONO SLOPE - PARAPET |

| | |
|-------------------|--|
| S-2.50 | ROOF FRAMING DETAILS - MONO SLOPE |
| S-2.51 | ROOF FRAMING DETAILS - DUAL SLOPE |
| S-2.60 | ROOF MISC. DETAILS |
| S-2.70 | ROOF FRAMING DETAILS - PARAPET |

| | |
|-------------------|---|
| S-3.01 | BUILDING SECTION - MONO SLOPE ROOF |
| S-3.02 | BUILDING SECTION - DUAL SLOPE ROOF |

| | |
|-------------------|--|
| S-3.03 | BUILDING SECTION - 0.030' MONO SLOPE ROOF |
| S-3.04 | BUILDING SECTION - 0.030' DUAL SLOPE ROOF |

| | |
|--------|--------------------------------------|
| S-5.00 | WALL FRAMING ELEVATIONS - WOOD STUDS |
| S-5.10 | WALL FRAMING DETAILS - WOOD STUDS |
| S-5.11 | WALL FRAMING DETAILS - WOOD STUDS |

| | |
|-------------------|--|
| S-5.20 | WALL FRAMING ELEVATIONS - STEEL STUDS |
| S-5.21 | WALL FRAMING DETAILS - STEEL STUDS |
| S-5.24 | WALL FRAMING DETAILS - STEEL STUDS |

PLUMBING

| | |
|--------------------|--|
| P-1.01A | PLUMBING PLAN AND ISOMETRICS - ADULT "MODEL A-1" OR "MODEL A-2" |
| P-1.01E | PLUMBING PLAN AND ISOMETRICS - ELEM. "MODEL A-1" OR "MODEL A-2" |
| P-1.02A | PLUMBING PLAN AND ISOMETRICS - ADULT "MODEL B-1" OR "MODEL B-2" |
| P-1.02E | PLUMBING PLAN AND ISOMETRICS - ELEM. "MODEL B-1" OR "MODEL B-2" |
| P-1.03A | PLUMBING PLAN AND ISOMETRICS - ADULT "MODEL C-1" OR "MODEL C-2" |
| P-1.03E | PLUMBING PLAN AND ISOMETRICS - ELEM. "MODEL C-1" OR "MODEL C-2" |
| P-1.04A | PLUMBING PLAN AND ISOMETRICS - ADULT "MODEL D-1" OR "MODEL D-2" |
| P-1.04E | PLUMBING PLAN AND ISOMETRICS - ELEM. "MODEL D-1" OR "MODEL D-2" |

| | |
|--------|-------------------------------|
| P-2.01 | PLUMBING DETAILS AND SCHEDULE |
|--------|-------------------------------|

MECHANICAL

| | |
|-------------------|---|
| M-0.1 | MECHANICAL NOTES, SCHEDULES, AND DETAILS |
| M-1.01 | MECHANICAL PLAN - WALL MOUNT "MODEL E" |
| M-2.01 | MECHANICAL PLAN - ROOF MOUNT "MODEL E" |

ELECTRICAL

| | |
|-------------------|--|
| E-1.01 | ELECTRICAL PLAN AND SCHEDULE - "MODEL A-1" OR "MODEL A-2" |
| E-1.02 | ELECTRICAL PLAN AND SCHEDULE - "MODEL B-1" OR "MODEL B-2" |
| E-1.03 | ELECTRICAL PLAN AND SCHEDULE - "MODEL C-1" OR "MODEL C-2" |
| E-1.04 | ELECTRICAL PLAN AND SCHEDULE - "MODEL D-1" OR "MODEL D-2" |

RAMP

| | |
|-------------------|--|
| R-1.01 | STANDARD RAMP PLAN |
| R-1.02 | OFFSET RAMP PLAN |
| R-1.03 | RAMP LANDING |
| R-1.04 | STANDARD LANDING WITH STEPS |
| R-1.05 | SWITCHBACK RAMP PLAN |
| R-2.01 | RAMP DETAILS |

RELOCATABLE SHEETS

| | |
|--------------------|--|
| REL-101 | BUILDING RELOCATION DETAILS |
|--------------------|--|

END OF TABLE OF LIST OF DRAWINGS

DOCUMENT 00 3100

INFORMATION AVAILABLE TO BIDDERS

PART 1 GENERAL

1.01 GEOTECHNICAL INVESTIGATION

A. Geotechnical Investigations for Liberty High School Campus Expansion and Memorandum are available for review through the Liberty Union High School District website at www.luhSD.net as well as through Lathrop Construction by sending an email to maria.galligan@lathropconstruction.com.

B. All Contractor Classifications licensed by the California State Contractors' License Board may purchase copies of the Geotechnical Investigations for the cost of printing at the facilities of Draftech Blueprinting, Inc., 1544 Terrace Way, Santa Rosa, CA 95404, (707) 578-9442. Orders shall be placed through the Architect's Office. Purchased copies are non-refundable.

C. Bidders are strongly encouraged to review this document(s) prior to bidding.

PART 2 PRODUCTS

2.01 Not Used.

PART 3 EXECUTION

3.01 Not Used.

END OF DOCUMENT

LIBERTY UNION HIGH SCHOOL DISTRICT

BIDDING DOCUMENTS

FOR THE

LIBERTY UNION HIGH SCHOOL DISTRICT

FOR

STADIUM IMPROVEMENTS

AT

LIBERTY HIGH SCHOOL

850 Second Street, Brentwood, CA 94513

Project No. 1722.00

DSA Application No. 01-11742

Bid No: U1809L

LIBERTY UNION HIGH SCHOOL DISTRICT

20 Oak Street, Brentwood, CA 94513

September 5, 2018

THIS PAGE INTENTIONALLY LEFT BLANK FOR PRINTING PURPOSES

NOTICE INVITING BIDS 1

INSTRUCTIONS TO BIDDERS 5

CHECKLIST OF MANDATORY BID FORMS 13

DESIGNATION OF SUBCONTRACTORS 15

DESIGNATION OF SUBCONTRACTORS FORM 16

BID FORM 18

CONTRACTOR’S CERTIFICATE REGARDING WORKERS’ COMPENSATION FORM..... 24

NON-COLLUSION DECLARATION..... 25

BID GUARANTEE FORM..... 26

BID BOND FORM..... 27

ACKNOWLEDGMENT OF BIDDING PRACTICES REGARDING INDEMNITY FORM..... 31

DISABLED VETERAN BUSINESS ENTERPRISE (DVBE) PARTICIPATION STATEMENT 32

CONTRACTOR’S CERTIFICATE REGARDING DRUG-FREE WORKPLACE..... 33

CONTRACTOR’S CERTIFICATE REGARDING ALCOHOLIC BEVERAGE AND TOBACCO-
FREE CAMPUS POLICY 34

AGREEMENT FORM..... 36

PAYMENT BOND..... 41

PERFORMANCE BOND..... 44

GUARANTEE 48

ESCROW AGREEMENT FOR SECURITY DEPOSITS IN LIEU OF RETENTION..... 49

INSURANCE DOCUMENTS & ENDORSEMENTS..... 52

| | |
|--|---|
| CONTRACTOR CERTIFICATION REGARDING BACKGROUND CHECKS | 54 |
| CONTRACTOR CERTIFICATION REGARDING BACKGROUND CHECKS | 55 |
| ARTICLE 1 | DEFINITIONS..... 56 |
| 1.1 | BASIC DEFINITIONS 56 |
| 1.2 | EXECUTION, CORRELATION AND INTENT 61 |
| 1.3 | OWNERSHIP AND USE OF ARCHITECT'S DRAWINGS, SPECIFICATIONS AND OTHER DOCUMENTS..... 65 |
| ARTICLE 2 | DISTRICT 66 |
| 2.1 | INFORMATION AND SERVICES REQUIRED OF THE DISTRICT 66 |
| 2.2 | DISTRICT'S RIGHT TO CARRY OUT THE WORK DUE TO PARTIAL DEFAULT IN A SPECIFIC SEGREGATED AREA OF WORK (48 HOUR NOTICE TO CURE AND CORRECT) 69 |
| ARTICLE 3 | THE CONTRACTOR..... 71 |
| 3.1 | SUPERVISION AND CONSTRUCTION PROCEDURES 71 |
| 3.2 | SUPERVISION 72 |
| 3.3 | LABOR AND MATERIALS 73 |
| 3.4 | WARRANTY 76 |
| 3.5 | TAXES..... 77 |
| 3.6 | PERMITS, FEES AND NOTICES..... 77 |
| 3.7 | SUBMITTALS REQUIRED AT THE COMMENCEMENT OF THE PROJECT 78 |
| 3.8 | DOCUMENTS, SAMPLES, AND COMPUTER AT THE SITE..... 79 |
| 3.9 | SUBMITTALS INCLUDING SHOP DRAWINGS, PRODUCT DATA, AND SAMPLES 79 |
| 3.10 | SUBSTITUTIONS..... 85 |
| 3.11 | INTEGRATION OF WORK 87 |
| 3.12 | CLEANING UP..... 88 |
| 3.13 | ACCESS TO WORK..... 89 |
| 3.14 | ROYALTIES AND PATENTS 90 |
| 3.15 | INDEMNIFICATION 90 |
| 3.16 | SUBMISSION OF DAILY REPORTS 90 |
| 3.17 | AS-BUILT DRAWINGS AND ANNOTATED SPECIFICATIONS 91 |
| 3.18 | EQUIPMENT MANUALS..... 92 |
| 3.19 | DIR REGISTRATION 93 |
| ARTICLE 4 | ADMINISTRATION OF THE CONTRACT AND CLAIMS..... 94 |
| 4.1 | ARCHITECT 94 |
| 4.2 | ARCHITECT'S ADMINISTRATION OF THE CONTRACT..... 94 |
| 4.3 | PROJECT INSPECTOR..... 96 |
| 4.4 | STOP WORK ORDER..... 98 |
| 4.5 | RESPONSIBILITY FOR ADDITIONAL CHARGES INCURRED BY THE DISTRICT FOR PROFESSIONAL SERVICES..... 98 |
| 4.6 | DISPUTES AND CLAIMS 99 |

| | | |
|------------|---|-----|
| ARTICLE 5 | SUBCONTRACTORS | 108 |
| 5.1 | DEFINITIONS..... | 108 |
| ARTICLE 6 | CONSTRUCTION BY DISTRICT OR BY SEPARATE CONTRACTORS..... | 110 |
| 6.1 | DISTRICT’S RIGHT TO PERFORM CONSTRUCTION AND TO AWARD SEPARATE CONTRACTS..... | 110 |
| 6.2 | CONSTRUCTIVE OWNERSHIP OF PROJECT SITE AND MATERIAL | 112 |
| 6.3 | DISTRICT’S RIGHT TO CLEAN UP | 112 |
| ARTICLE 7 | CHANGES IN THE WORK | 113 |
| 7.1 | CHANGES..... | 113 |
| 7.2 | CHANGE ORDERS (“CO”) | 114 |
| 7.3 | CONSTRUCTION CHANGE DOCUMENT (CCD Category A, and CCD Category B) and WORK DIRECTIVE (WD)..... | 114 |
| 7.4 | REQUEST FOR INFORMATION (“RFI”) | 115 |
| 7.5 | REQUEST FOR PROPOSAL (“RFP”)..... | 116 |
| 7.6 | CHANGE ORDER REQUEST (“COR”)..... | 117 |
| 7.7 | COST OF CHANGE ORDERS..... | 117 |
| ARTICLE 8 | TIME AND SCHEDULE | 124 |
| 8.1 | DEFINITIONS..... | 124 |
| 8.2 | HOURS OF WORK..... | 126 |
| 8.3 | PROGRESS AND COMPLETION | 126 |
| 8.4 | EXTENSIONS OF TIME - LIQUIDATED DAMAGES..... | 130 |
| ARTICLE 9 | PAYMENTS AND COMPLETION..... | 134 |
| 9.1 | CONTRACT SUM | 134 |
| 9.2 | COST BREAKDOWN | 134 |
| 9.3 | PROGRESS PAYMENTS..... | 135 |
| 9.4 | APPLICATIONS FOR PROGRESS PAYMENTS..... | 137 |
| 9.5 | STOP NOTICE CLAIMS AND WARRANTY OF TITLE | 139 |
| 9.6 | DECISIONS TO WITHHOLD PAYMENT..... | 140 |
| 9.7 | NONCONFORMING WORK..... | 141 |
| 9.8 | SUBCONTRACTOR PAYMENTS | 142 |
| 9.9 | COMPLETION OF THE WORK..... | 142 |
| 9.10 | PARTIAL OCCUPANCY OR USE..... | 147 |
| 9.11 | COMPLETION AND FINAL PAYMENT | 148 |
| 9.12 | SUBSTITUTION OF SECURITIES | 151 |
| ARTICLE 10 | PROTECTION OF PERSONS AND PROPERTY | 152 |
| 10.1 | SAFETY PRECAUTIONS AND PROGRAMS | 152 |
| 10.2 | SAFETY OF PERSONS AND PROPERTY | 154 |
| 10.3 | EMERGENCIES | 157 |
| 10.4 | HAZARDOUS MATERIALS | 157 |
| 11 | INSURANCE AND BONDS..... | 185 |
| | PERFORMANCE AND PAYMENT BONDS..... | 185 |

| | | |
|-------|--|-----|
| 11.1 | BOND REQUIREMENTS | 185 |
| 12 | UNCOVERING AND CORRECTION OF WORK..... | 186 |
| 12.1 | COMPLIANCE WITH TITLE 24 INSTALLATION REQUIREMENTS | 186 |
| 12.2 | SPECIAL NOTICE OF AMERICAN'S WITH DISABILITIES ACT | 186 |
| 12.3 | UNCOVERING OF WORK..... | 187 |
| 12.4 | CORRECTION OF WORK..... | 187 |
| 13 | MISCELLANEOUS PROVISIONS..... | 189 |
| 13.1 | GOVERNING LAW | 189 |
| 13.2 | SUCCESSORS AND ASSIGNS | 189 |
| 13.3 | WRITTEN NOTICE..... | 189 |
| 13.4 | RIGHTS AND REMEDIES | 189 |
| 13.5 | TESTS AND INSPECTIONS..... | 189 |
| 13.6 | TRENCH EXCAVATION | 190 |
| 13.7 | WAGE RATES, TRAVEL, AND SUBSISTENCE | 191 |
| 13.8 | RECORDS OF WAGES PAID | 193 |
| 13.9 | APPRENTICES | 195 |
| 13.10 | ASSIGNMENT OF ANTITRUST CLAIMS | 196 |
| 13.11 | STATE AND DISTRICT CONDUCTED AUDITS | 196 |
| 13.12 | STORM WATER POLLUTION PREVENTION | 198 |
| 14 | TERMINATION OR SUSPENSION OF THE CONTRACT..... | 202 |
| 14.1 | TERMINATION BY THE CONTRACTOR FOR CAUSE..... | 202 |
| 14.2 | TERMINATION BY THE DISTRICT FOR CAUSE..... | 202 |
| 14.3 | TERMINATION OF CONTRACT BY DISTRICT (CONTRACTOR NOT AT FAULT) | 203 |
| 14.4 | REMEDIES OTHER THAN TERMINATION | 204 |
| 15 | DEBARMENT..... | 206 |
| | DEBARMENT MEANS THERE HAS BEEN A FINDING THAT THE CONTRACTOR IS NOT RESPONSIBLE. | 206 |
| 15.1 | BOARD FINDING..... | 206 |
| 15.2 | HEARING AND PRESENTATION OF EVIDENCE | 206 |

NOTICE INVITING BIDS

LIBERTY UNION HIGH SCHOOL DISTRICT

NOTICE IS HEREBY GIVEN that the Liberty Union High School District, acting by and through its Governing Board, hereinafter referred to as "District", will receive prior to 2:00PM on the January 22, 2019 sealed bids for the award of a Contract for the following:

BID NO. U1809L

Liberty High School Stadium Improvements (as described below):

Project will provide a new pre-engineered 2,200 seating capacity home bleacher and press box. A new single-story Fitness Building will be provided underneath the new bleacher. The Fitness Building is approximately 4,170 square feet and consists of a Weight Room, Team Room, Toilet Rooms and Storage Rooms. The Fitness Building is construction Type 5-A and Occupancy Type E, and will be protected automatic fire sprinkler system. Adjacent site development will include four exterior basketball courts and fenced exterior storage areas.

Project will provide a new Concession Building and Stadium Entry Plaza. The single-story Concession Building is approximately 2,300 square feet and primary spaces include a Concession area, bulk Storage Room, Girls Toilet Room, Boys Toilet Room, and a Ticket Window room. The building is of Type 5-B construction and Occupancy Type B. The building will not be provided automatic fire sprinkler system.

Project will include providing a pad and utility service to a District provided pre-manufactured portable Toilet Building at the northeast corner of the football field. The Toilet Building is approximately 480 square feet (12'x40').

New site work will include a new Stadium Entry plaza with concrete paving and landscaping. The existing student parking lots will be adjusted to allow for the entry plaza with new perimeter parking stalls.

Liberty High School Stadium Improvements:

All bids shall be made and presented only on the forms presented by the District. Bids shall be received in the Office of the Liberty Union High School District at 20 Oak Street, Brentwood, California 94513 and shall be opened and publicly read aloud at the above state time and place. Any bids received after the time specified above or after any extensions due to material changes shall be returned unopened.

The Contract Time is 171 calendar days.

CONTRACTOR should consult the General Conditions, Supplementary Conditions, and General Requirements regarding Milestones and Liquidated Damages.

Additive/ Deductive Bid Alternates (See Section 13 of Instruction to Bidders)

NONE

Miscellaneous Information

Bids shall be received in the place identified above and shall be opened and publicly read aloud at the above-stated time and place.

The bid documents are available on the Liberty Union High School District website at www.luhisd.net as well as through Lathrop Construction by sending an email to maria.galligan@lathropconstruction.com.

PREQUALIFICATION OF PRIME CONTRACTORS AND MEP SUBCONTRACTORS IS REQUIRED FOR THIS PROJECT. Prequalification questionnaires will be available with the bid documents mentioned above and will also be distributed at the mandatory Pre-Bid Conference. Completed prequalification questionnaires must be returned to the district by Tuesday, January 8, 2019.

There will be a mandatory Pre-Bid Conference on January 4th, 2019 at 10AM at the Liberty Union High School District Office, 20 Oak Street, Brentwood, CA 94513. Any Contractor bidding on the Project who fails to attend the entire mandatory job walk and conference will be deemed a non-responsive bidder and will have its bid returned unopened.

Each bidder shall be a licensed contractor pursuant to the California Business and Professions Code, and be licensed to perform the work called for in the Contract Documents. The successful bidder must possess a valid and active Class A or B License at the time of bid and throughout the duration of this Contract. The Contractor's California State License number shall be clearly stated on the bidder's proposal

Subcontractors shall be licensed pursuant to California law for the trades necessary to perform the Work called for in the Contract Documents.

Each bid must strictly conform with and be responsive to the Contract Documents as defined in the General Conditions.

The District reserves the right to reject any or all bids or to waive any irregularities or informalities in any bids or in the bidding.

Each bidder shall submit with its bid — on the form furnished with the Contract Documents — a list of the designated subcontractors on this Project as required by the Subletting and Subcontracting Fair Practices Act, California Public Contract Code section 4100 et seq.

In accordance with California Public Contract Code section 22300, the District will permit the substitution of securities for any moneys withheld by the District to ensure performance under the Contract. At the request and expense of the Contractor, securities equivalent to the amount withheld shall be deposited with the District, or with a state or federally chartered bank as the escrow agent, who shall then pay such moneys to the Contractor. Upon satisfactory completion of the Contract, the securities shall be returned to the Contractor.

Each bidder's bid must be accompanied by one of the following forms of bidder's security: (1) cash; (2) a cashier's check made payable to the District; (3) a certified check made payable to the District; or (4) a bidder's bond executed by a California admitted surety as defined in Code of Civil Procedure section 995.120, made payable to the District in the form set forth in the Contract Documents. Such bidder's security must be in an amount not less than ten percent (10%) of the maximum amount of bid as a guarantee that the bidder will enter into the proposed Contract, if the same is awarded to such bidder, and will provide the required Performance and Payment Bonds, insurance certificates and any other required documents. In the event of failure to enter into said Contract or provide the necessary documents, said security will be forfeited.

The Contractor and all subcontractors shall comply with the requirements set forth in Division 2, Part 7, Chapter 1 of the Labor Code. The District has obtained from the Director of the Department of Industrial Relations the general prevailing rate of per diem wages and the general prevailing rate for holiday and overtime work in the locality in which this work is to be performed for each craft, classification or type of worker needed to execute the Contract. These per diem rates, including holiday and overtime work, as well as employer payments for health and welfare, pension, vacation, and similar purposes, are on file at the District, and are also available from the Director of the Department of Industrial Relations. Pursuant to California Labor Code section 1720 et seq., it shall be mandatory upon the Contractor to whom the Contract is awarded, and upon any subcontractor under such Contractor, to pay not less than the said specified rates to all workers employed by them in the execution of the Contract.

A contractor or subcontractor shall not be qualified to bid on, be listed in a bid proposal, subject to the requirements of Section 4104 of the Public Contract Code, or engage in the performance of any contract for public work, as defined in the Labor Code, unless currently registered and qualified to perform public work pursuant to Labor Code section 1725.5. It is not a violation of this section for an unregistered contractor to submit a bid that is authorized by Section 7029.1 of the Business and Professions Code or by Section 10164 or 20103.5 of the Public Contract Code, provided the contractor is registered to perform public work pursuant to Section 1725.5 at the time the contract is awarded.

The Contractor and all subcontractors shall furnish certified payroll records as required pursuant Labor Code section 1776 directly to the Labor Commissioner in accordance with Labor Code section 1771.4 on at least on a monthly basis (or more frequently if required by the District or the Labor Commissioner) and in a format prescribed by the Labor Commissioner. Monitoring and enforcement of the prevailing wage laws and related requirements will be performed by the Labor Commissioner/ Department of Labor Standards Enforcement (DLSE).

No bidder may withdraw any bid for a period of ninety (90) calendar days after the date set for the opening of bids.

Separate payment and performance bonds, each in an amount equal to 100% of the total Contract amount, are required, and shall be provided to the District prior to execution of the Contract and shall be in the form set forth in the Contract Documents.

All bonds (Bid, Performance, and Payment) must be issued by a California admitted surety as defined in California Code of Civil Procedure section 995.120.

Where applicable, bidders must meet the requirements set forth in Public Contract Code section 10115 et seq., Military and Veterans Code section 999 et seq. and California Code of Regulations, Title 2, Section 1896.60 et seq. regarding Disabled Veteran Business Enterprise ("DVBE") Programs. Forms are included in this Bid Package.

Any request for substitutions pursuant to Public Contract Code section 3400 must be made at the time of Bid on the Substitution Request Form set forth in the Contract Documents and included with the bid.

No telephone or facsimile machine will be available to bidders on the District premises at any time.

It is each bidder's sole responsibility to ensure its bid is timely delivered and received at the location designated as specified above. Any bid received at the designated location after the scheduled closing time for receipt of bids shall be returned to the bidder unopened.

LIBERTY UNION HIGH SCHOOL DISTRICT

INSTRUCTIONS TO BIDDERS

1. **Preparation of Bid Form.** Proposals under these specifications shall be submitted on the blank forms furnished herewith at the time and place stated in the Notice Inviting Bids. All blanks in the bid form must be appropriately filled in, and all proposed prices must be stated clearly and legibly in both words and numerals. All bids must be signed by the bidder in permanent blue ink and submitted in sealed envelopes, bearing on the outside, the bidder's name, address, telephone number, and California Contractor's License number, and the name of the Project for which the bid is submitted. The District reserves the right to reject any bid if all of the above information is not furnished. It is each bidder's sole responsibility to ensure its bid is timely delivered and received at the location designated as specified above. Any bid received at the designated location after the scheduled closing time for receipt of bids shall be returned to the bidder unopened.

2. **Bid Security.** Each bid must be accompanied by one of the following forms of bidder's security: (1) cash; (2) a cashier's check made payable to the District; (3) a certified check made payable to the District; or (4) a bidder's bond executed by a California admitted surety as defined in Code of Civil Procedure section 995.120, made payable to the District, in the form set forth in the Contract Documents. Such bidder's security must be in an amount not less than ten percent (10%) of the maximum amount of such bidder's bid as a guarantee that the bidder will enter into the Contract, if the same is awarded to such bidder, and will provide the required Performance and Payment Bonds, insurance certificates and any other required documents. In the event that a bidder is awarded the Contract and such bidder fails to enter into said Contract or provide the surety bond or bonds within five (5) calendar days after award of the Contract to bidder, said security will be forfeited.

3. **Signature.** The bid form, all bonds, all designations of subcontractors, the Contractor's Certificate, the Agreement, and all Guarantees must be signed in permanent blue ink in the name of the bidder and must bear the signature in longhand of the person or persons duly authorized to sign the bid.

If bidder is a corporation, the legal name of the corporation shall first be set forth, together with two signatures: one from the President and one from the Secretary or Assistant Secretary. Alternatively, the signature of other authorized officers or agents may be affixed, if a certified copy of the resolution of the corporate board of directors authorizing them to do so is provided to the District. Such documents shall include the title of such signatories below the signature and shall bear the corporate seal.

If bidder is a partnership, the true name of the firm shall first be set forth, together with the names of all persons comprising the partnership or co-partnership. The bid must be signed by all partners comprising the partnership unless proof in the form of a certified copy of a statement of partnership acknowledging the signer to be a general partner is presented to the District, in which case the general partner may sign.

Bids submitted as joint ventures must so state and be signed by each joint venturer.

Bids submitted by individuals must be signed by the bidder unless an up to date power-of-attorney is on file in the District office, in which case, said person may sign for the individual.

The above rules also apply in the case of the use of a fictitious firm name. In addition, however, where a fictitious name is used, it must be so indicated in the signature.

4. Modifications. Changes in or additions to the bid form, recapitulations of the work bid upon, alternative proposals, or any other modification of the bid form which is not specifically called for in the Contract Documents may result in the District's rejection of the bid as not being responsive to the Notice Inviting Bids. **No oral or telephonic modification of any bid submitted will be considered.**

5. Erasures, Inconsistent or Illegible Bids. The bid submitted must not contain any erasures, interlineations, or other corrections unless each such correction creates no inconsistency and is suitably authenticated by affixing in the margin immediately opposite the correction the signature or signatures of the person or persons signing the bid. In the event of inconsistency between words and figures in the bid price, words shall control figures. In the event that the District determines that any bid is unintelligible, inconsistent, or ambiguous, the District may reject such bid as not being responsive to the Notice Inviting Bids.

6. Examination of Site and Contract Documents. Each bidder shall visit the site of the proposed work and become fully acquainted with the conditions relating to the construction and labor so that the facilities, difficulties, and restrictions attending the execution of the work under the Contract are fully understood. Bidders shall thoroughly examine and be familiar with the drawings and specifications and all other documents and requirements that are attached to and/or contained in the Project Manual or other documents issued to bidders. The failure or omission of any bidder to receive or examine any Contract Documents, form, instrument, addendum, or other document or to visit the site and become acquainted with conditions there existing shall not relieve any bidder from obligations with respect to the bid or to the contract. The submission of a bid shall be taken as prima facie evidence of compliance with this Section. Bidders shall not, at any time after submission of the bid, dispute, complain, or assert that there were any misunderstandings with regard to the nature or amount of work to be done.

7. Withdrawal of Bids. Any bid may be withdrawn, either personally or by written request, at any time prior to the scheduled closing time for receipt of bids. The bid security for bids withdrawn prior to the scheduled closing time for receipt of bids, in accordance with this paragraph, shall be returned upon demand therefor.

No bidder may withdraw any bid for a period of ninety (90) calendar days after the date set for the opening of bids.

8. Agreements, Insurance and Bonds. The Agreement form which the successful bidder, as Contractor, will be required to execute, and the forms and amounts of surety bonds and insurance endorsements which Contractor will be required to be furnished at the time of execution of the Agreement, are included in the bid documents and should be carefully examined by the bidder. The number of executed copies of the Agreement, the Performance Bond, and the Payment Bond required is three (3). Payment and Performance bonds must be executed by an admitted surety insurer as defined in Code of Civil Procedure 995.120.

9. Interpretation of Plans and Documents/Pre-Bid Clarification. If any prospective bidder is in doubt as to the true meaning of any part of the Contract Documents, or finds discrepancies in, or omissions, a written request for an interpretation or correction thereof may be submitted to the District. The bidder submitting the request shall be responsible for its prompt delivery. **Any interpretation or correction of the Contract Documents will only be made by Addendum duly issued, and a copy of such Addendum will be made available for each contractor receiving a set of the Contract Documents.** No person is authorized to make any oral interpretation of any provision in the Contract Documents, nor shall any oral interpretation be binding on the District. If discrepancies on drawings, specifications or elsewhere in the Contract Documents are not covered by addenda, bidder shall include in their bid methods of construction

and materials for the higher quality and complete assembly. Each request for clarification shall be submitted in writing, via email, to only the following persons:

TO: Avian Soupholphakdy (QKA Architects)
avians@qka.com

Each transmitted request shall contain the name of the person and/or firm filing the request, address, telephone, and fax number, Specifications and/or Drawing number. Bidder is responsible for the legibility of hand written requests. Pre-bid clarification request shall be filed a minimum of **six (6)** days prior to bid opening. Requests received less than **six (6)** days before bid opening shall not be considered or responded to. A written response to timely pre-bid clarifications requests which materially affects the bidders price will be made by Bid Clarification or Addendum issued by the District not less than seventy-two (72) hours prior to bid opening.

10. Bidders Interested in More Than One Bid. No person, firm, or corporation shall be allowed to make, or file, or be interested in more than one prime bid for the same work unless alternate bids are specifically called for. A person, firm, or corporation that has submitted a proposal to a bidder, or that has quoted prices of materials to a bidder, is not thereby disqualified from submitting a proposal or quoting prices to other bidders or making a prime proposal.

11. Award of Contract. The Contract will be awarded to the lowest responsive responsible bidder by action of the governing Board. The District reserves the right to reject any or all bids, or to waive any irregularities or informalities in any bids or in the bidding. In the event an award is made to bidder, and such bidder fails or refuses to execute the Contract and provide the required documents within five (5) calendar days after award of the Contract to bidder, the District may award the Contract to the next lowest responsible and responsive bidder or release all bidders. **Each bid must conform and be responsive to the Contract Documents as defined in the General Conditions.**

12. Bid Protest Procedure. Any bidder may file a bid protest. The protest shall be filed in writing with the District's Facilities Director not more than five (5) business days after the date of the bid opening. An e-mail address shall be provided and by filing the protest, protesting bidder consents to receipt of e-mail notices for purposes of the protest and protest related questions and protest appeal, if applicable. The protest shall specify the reasons and facts upon which the protest is based.

a. Resolution of Bid Controversy: Once the bid protest is received, the apparent lowest responsible bidder will be notified of the protest and the evidence presented. If appropriate, the apparent low bidder will be given an opportunity to rebut the evidence and present evidence that the apparent low bidder should be allowed to perform the Work. If deemed appropriate by the District, an informal hearing will be held. District will issue a written decision within fifteen (15) calendar days of receipt of the protest, unless factors beyond the District's reasonable control prevent such resolution. The decision on the bid protest will be copied to all parties involved in the protest.

b. Appeal: If the protesting bidder or the apparent low bidder is not satisfied with the decision, the matter may be appealed to the Chief Business Officer or their designee, within three (3) business days after receipt of the District's written decision on the bid protest. The appeal must be in writing and sent via overnight registered mail with all accompanying information relied upon for the appeal and an e-mail address from which questions and responses may be provided to:

**Liberty Union High School District
Business Department
20 Oak Street, Brentwood, CA 94513**

c. Appeal Review: The Chief Business Officer or their designee shall review the decision on the bid protest from the Director of Facilities and issue a written response to the appeal, or if appropriate, appoint a Hearing Office to conduct a hearing and issue a written decision. The written decision of the Chief Business Officer or the Hearing Officer shall be rendered within fifteen (15) calendar days and shall state the basis for the decision. The decision concerning the appeal will be final and not subject to any further appeals.

d. Reservation of Rights to Proceed with Project Pending Appeal. The District reserves the right to proceed to award the Project and commence construction pending an Appeal. If there is State Funding or a critical completion deadline, the District may choose to shorten the time limits set forth in this Section if written notice is provided to the protesting party. E-mailed notice with a written confirmation sent by First Class Mail shall be sufficient to constitute written notice. If there is no written response to a written notice shortening time, the District may proceed with the award.

e. Finality. Failure to comply with this Bid Protest Procedure shall constitute a waiver of the right to protest and shall constitute a failure to exhaust the protesting bidder's administrative remedies.

13. Alternates. If alternate bids are called for, the Contract may be awarded at the election of the Governing Board to the lowest responsible and responsive bidder using the method and procedures outlined in the Notice Inviting Bids and as specified in the section entitled Alternate/Deductive Bid Alternates.

a. Subcontractor Listing for Alternates. If alternate bids are called for and the bidder intends to use different or additional subcontractors, a separate list of subcontractors must be submitted for each such alternate.

14. Evidence of Responsibility. Upon the request of the District, a bidder whose bid is under consideration for the award of the Contract shall submit promptly to the District satisfactory evidence showing the bidder's financial resources, surety and insurance claims experience, construction experience, completion ability, workload, organization available for the performance of the Contract, and other factors pertinent to a Project of the scope and complexity involved.

15. Listing Subcontractors. Each bidder shall submit with his bid, on the form furnished with the Contract Documents, a list of the names, license numbers, scopes of work, locations of the places of business, contact information, and Department of Industrial Relations ("DIR") registration numbers of each subcontractor who will perform work or labor or render service to the bidder in or about the project, or a subcontractor who under subcontract to the bidder, specially fabricates and installs a portion of the work, in an amount in excess of one-half of 1 percent of the bidder's total bid as required by the Subletting and Subcontracting Fair Practices Act (Public Contract Code section 4100, et seq.) Pursuant to Labor Code section 1725.5, all subcontractors (of any tier) performing work on this Project must be properly registered with DIR.

16. Workers' Compensation. In accordance with the provisions of Labor Code section 3700, the successful bidder as the Contractor shall secure payment of compensation to all employees. The Contractor shall sign and file with the District the following certificate prior to performing the work under this contract: "I am aware of the provisions of Section 3700 of the Labor Code, which requires every employer to be insured against liability for workers' compensation or to undertake self-insurance in accordance with the

provisions of that code, and I will comply with such provisions before commencing the performance of the work of this contract.” The form of such certificate is included as a part of the Bid Documents.

17. Contractor’s License. To perform the work required by this notice, the Contractor must possess the Contractor’s License as specified in the Notice Inviting Bids, and the Contractor must maintain the license throughout the duration of the contract. If, at the time of bid, bidder is not licensed to perform the Project in accordance with Division 3, Chapter 9, of the Business and Professions Code for the State of California and the Notice to Contractors calling for bids, such bid will not be considered and the Contractor will forfeit its bid security to the District.

18. Anti-Discrimination. It is the policy of the District that in connection with all work performed under contracts, there be no discrimination against any prospective or active employee engaged in the work because of race, color, ancestry, national origin, religious creed, sex, age, or marital status. The Contractor agrees to comply with applicable federal and California laws, including, but not limited to, the California Fair Employment and Housing Act, beginning with Government Code section 12900 and Labor Code section 1735. In addition, the Contractor agrees to require like compliance by any subcontractors employed on the work by such Contractor.

19. Preference for Materials and Substitutions.

a. One Product Specified. Unless the Plans and Specifications state that no Substitution is permitted, whenever the Contract Documents indicate any specific article, device, equipment, product, material, fixture, patented process, form, method, construction, or any specific name, make, trade name, or catalog number, with or without the words, “or equal,” such specification shall be read as if the language “or equal” is incorporated.

b. Request for Substitution. Bidder may, unless otherwise stated, offer any material, process, article, etc., which is materially equal or better in every respect to that so indicated or specified (“Specified Item”) and will completely accomplish the purpose of the Contract Document. If bidder desires to offer a Substitution for a Specified Item, such bidder must make a request in writing on the District’s Substitution Request Form and submit the completed Request Form for review within the time frame established by Project Requirements Specification Section 01 6000, article 3.01. The Request Form must be accompanied by evidence in full conformance with Specification Section 01 6000 including whether the proposed substitution:

- 1) Is equal in quality, service, and ability to the Specified Item as demonstrated by a side by side comparison of key characteristics and performance criteria (CSI comparison chart);
- 2) Will entail no changes in detail, construction and scheduling of related work;
- 3) Will be acceptable in consideration of the required design and artistic effect;
- 4) Will provide no cost disadvantage to the District;
- 5) Will require no excessive or more expensive maintenance, including adequacy and availability of replacement parts; and
- 6) Will require no change in the Contract Time.

After the District’s receipt of such evidence by bidder, the District will make its final decision as to whether the bidder’s request for Substitution for any Specified Items will be granted. The District shall have sole discretion in deciding as to whether a proposed request for Substitution is equal to or better than a Specified Item. Any request for Substitution which is granted by the District shall be documented and processed through a Bid Clarification or Addendum. The District may condition its approval of any Substitution upon delivery to the District of an extended warranty or other assurances of

adequate performance of the Substitution. Any and all risks of delay due to DSA, or any other governmental agency having jurisdiction shall be on the bidder.

20. Disqualification of Bidders and Proposals. More than one proposal for the same work from any individual, firm, partnership, corporation, or association under the same or different names will not be accepted; and reasonable grounds for believing that any bidder is interested in more than one proposal for the work will be cause for rejecting all proposals in which such bidder is interested and the bidder will forfeit their bid security to the District.

21. Unbalanced or Altered Bids. Proposals in which the prices are obviously unbalanced, and those which are incomplete or show any alteration of form, or contain any additions or conditional or alternate bids that are not called for or otherwise permitted, may be rejected. A proposal on which the signature of the bidder has been omitted may be rejected. If, in the District's sole discretion, it determines any pricing, costs or other information submitted by a bidder may result in an unbalanced bid, the District may deem such bid non-responsive. A bid may be determined by the District to be unbalanced if the bid is based on prices significantly less than cost for some work and prices which are significantly overstated in relation to cost for other work, and if there is a reasonable doubt that the bid will result in the lowest overall cost to the District even though it may be the low evaluated bid, or if it is so unbalanced as to be tantamount to allowing an advanced payment.

22. Employment of Apprentices. The Contractor and all Subcontractors shall comply with the provisions of California Labor Code including, but not limited to sections 1777.5, 1777.6, and 1777.7 concerning the employment of apprentices. The Contractor and any Subcontractor under him shall comply with the requirements of said sections, including applicable portions of all subsequent amendments in the employment of apprentices; however, the Contractor shall have full responsibility for compliance with said Labor Code sections, for all apprenticeable occupations, regardless of any other contractual or employment relationships alleged to exist.

23. Non-Collusion Declaration. Public Contract Code section 7106 requires bidders to submit declaration of non-collusion with their bids. This form is included with the bid documents and must be signed and dated by the bidder under penalty of perjury.

24. Wage Rates, Travel and Subsistence.

a. The Contractor and all subcontractors shall comply with the requirements set forth in Division 2, Part 7, Chapter 1 of the Labor Code. Pursuant to Labor Code section 1770 et seq., the District has obtained from the Director of the Department of Industrial Relations the general prevailing rate of per diem wages and the general prevailing rate for holiday and overtime work in the locality in which this work is to be performed for each craft, classification or type of worker needed to execute the contract. Copies are available from the District to any interested party on request and are also available from the Director of the Department of Industrial Relations. The Contractor shall obtain copies of the above-referenced prevailing wage sheets and post a copy of such wage rates at appropriate, conspicuous, weatherproof points at the Site.

b. Any worker employed to perform work on the Project and such work is not covered by any classification listed in the published general prevailing wage rate determinations or per diem wages determined by the Director of the Department of Industrial Relations, shall be paid not less than the minimum rate of wages specified therein for the classification which most nearly corresponds to the employment of such person in such classification.

c. Holiday and overtime work, when permitted by law, shall be paid for at the rate set forth in the prevailing wage rate determinations issued by the Director of the Department of Industrial Relations

or at least one and one-half (1½) times the specified basic rate of per diem wages, plus employer payments, unless otherwise specified in the Contract Documents or authorized by law.

d. These per diem rates, including holiday and overtime work, and employer payments for health and welfare, pension, vacation, and similar purposes, are on file at the administrative office of the District, located as noted above and are also available from the Director of the Department of Industrial Relations. It is the Contractor's responsibility to ensure the appropriate prevailing rates of per diem wages are paid for each classification. It shall be mandatory upon the Contractor to whom the Contract is awarded, and upon any subcontractor under such Contractor, to pay not less than the said specified rates to all workers employed by them in the execution of the Contract.

25. DIR Registration of Contractor and Subcontractors. A contractor or subcontractor shall not be qualified to bid on, be listed in a bid proposal, subject to the requirements of Section 4104 of the Public Contract Code, or engage in the performance of any contract for public work, as defined in the Labor Code, unless currently registered and qualified to perform public work pursuant to Section 1725.5. It is not a violation of this section for an unregistered contractor to submit a bid that is authorized by Section 7029.1 of the Business and Professions Code or by Section 10164 or 20103.5 of the Public Contract Code, provided the contractor is registered to perform public work pursuant to Section 1725.5 at the time the contract is awarded.

This Project is a public works project as defined in Labor Code section 1720. Each contractor bidding on this Project and all subcontractors (of any tier) performing any portion of the Work must comply with the Labor Code sections 1725.5 and 1771.1 and must be properly and currently registered with DIR and qualified to perform public works pursuant to Labor Code section 1725.5 throughout the duration of the Project. For more information and up to date requirements, contractors are recommended to periodically review the DIR's website at www.dir.ca.gov. Contractor shall be solely responsible for ensuring compliance with Labor Code section 1725.5 as well as any requirements implemented by DIR applicable to its services or its subcontractors throughout the term of the Agreement and in no event shall contractor be granted increased payment from the District or any time extensions to complete the Project as a result of contractor's efforts to maintain compliance with the Labor Code or any requirements implemented by the DIR. Failure to comply with these requirements shall be deemed a material breach of this Agreement and grounds for termination for cause. The contractor and all subcontractors shall furnish certified payroll records as required pursuant Labor Code section 1776 directly to the Labor Commissioner in accordance with Labor Code section 1771.4 on at least on a monthly basis (or more frequently if required by the District or the Labor Commissioner) and in a format prescribed by the Labor Commissioner. The District reserves the right to withhold contract payments if the District is notified, or determines as the result of its own investigation, that contractor is in violation of any of the requirements set forth in Labor Code section 1720 et seq. at no penalty or cost to the District. Monitoring and enforcement of the prevailing wage laws and related requirements will be performed by the Labor Commissioner/ Department of Labor Standards Enforcement (DLSE).

26. No Telephone or Facsimile Availability. No telephone or facsimile machine will be available to bidders on the District premises at any time.

27. Obtaining Bidding Documents. Bidding Documents, may be obtained from:

Liberty Union High School District Website – www.luhsd.net

Lathrop Construction – email Maria Galligan at maria.galligan@lathropconstruction.com

Bidder shall utilize a complete set of Bidding Documents in preparing a bid. The failure or omission of bidder to receive any Bidding Document, form, instrument, Addendum, or other document shall not relieve bidder from any obligations with respect to the bid and/or Contract.

28. Addenda. Clarification or any other notice of a change in the Bidding Documents will be issued only by the District and only in the form of a written Addendum, transmitted by fax, e-mail, or available for pick up to all who are known by the issuing office to have received a complete set of Bidding Documents. Any other purported Addenda are void and unenforceable.

Bidder is responsible for ascertaining the disposition of all Addenda issued regardless of District notification and to acknowledge all Addenda in the submitted sealed bid prior to the bid opening. Copies of Addenda will be made available for inspection wherever Bidding Documents are on file for inspection. Each Addendum will be numbered, dated, and identified with the Project number. Oral statements or any instructions in any form, other than Addendum as described above, shall be void and unenforceable. Addenda issued by the District and not noted as being acknowledged by bidder as required in the Bid Form, may result in the bid being deemed non-responsive.

29. Debarment. Bidder may also be subject to debarment, in addition to seeking remedies for False Claims under Government Code section 12650 et seq. and Penal Code section 72, the District may debar a Contractor pursuant to Article 15 of the General Conditions if the Board, or the Board may designate a hearing officer who, in his or her discretion, finds the Contractor has done any of the following:

- a. Intentionally or with reckless disregard, violated any term of a contract with the District
- b. Committed an act or omission which reflects on the Contractor's quality, fitness or capacity to perform work for the District;
- c. Committed an act or offense which indicates a lack of business integrity or business honesty; or,
- d. Made or submitted a false claim against the District or any other public entity (See Government Code section 12650, et seq., and Penal Code section 72)

CHECKLIST OF MANDATORY BID FORMS

(For Contractor's use and reference only. Additional documents may be required so bidders should carefully review all Contract Documents and Bid Documents)

- Designation of Subcontractors
- Bid Form
- Contractor's Certificate Regarding Workers Compensation
- Non-Collusion Declaration
- Bid Bond (or Bid Guarantee form if Security is other than Bid Bond)
- Acknowledgment of Bidding Practices Regarding Indemnity
- DVBE Participation Statement
- Contractor's Certificate Regarding Drug-Free Work Place
- Contractor's Certificate Regarding Alcoholic Beverage and Tobacco-Free Campus Policy

PRE-BID CLARIFICATION FORM (For Contractor's Use)

| | | | |
|-----------------|--|--------|----------------|
| PROJECT NAME: | Liberty High School Stadium Improvements | | |
| PROJECT NUMBER: | TBD | | |
| TO: | Avian Soupholphakdy | EMAIL: | avians@qka.com |

| | | | |
|---------------------------|--|-----------------|--|
| DATE: | | | |
| FROM: | | EMAIL: | |
| DOCUMENT/DIVISION NUMBER: | | DRAWING NUMBER: | |

| |
|--------------------------|
| REQUESTED CLARIFICATION: |
| |

| |
|---|
| RESPONSE TO CLARIFICATION: Only by Bid Clarification or Addendum |
| |

Attach additional numbered sheets as necessary; however, only one (1) request shall be contained on each submitted form.

DESIGNATION OF SUBCONTRACTORS

In compliance with the Subletting and Subcontracting Fair Practices Act (California Public Contract Code section 4100 et seq.,) and any amendments thereof, each Bidder shall set forth below: (a) the name, license number, and location of the place of business of each subcontractor who will perform work or labor or render service to the Contractor, who will perform work or labor or work or improvement to be performed under this Contract, or a subcontractor licensed by the State of California who, under subcontract to the Contractor, specially fabricates and installs a portion of the work or improvements according to detailed Drawings contained in the Plans and Specifications in an amount in excess of one-half of one percent of the Contractor's total bid; and (b) the portion and description of the work which will be done by each subcontractor under this Act. The Contractor shall list only one subcontractor for each such portion as is defined by the Contractor in this bid. All subcontractors shall be properly licensed by the California State Licensing Board.

If a Contractor fails to specify a subcontractor, or if a Contractor specifies more than one subcontractor for the same portion of work to be performed under the Contract in excess of one-half of one percent of the Contractor's total bid, the Contractor shall be deemed to have agreed that the Contractor is fully qualified to perform that portion, and that the Contractor alone shall perform that portion.

No Contractor whose bid is accepted shall (a) substitute any subcontractor, (b) permit any subcontractor to be voluntarily assigned or transferred or allow the relevant portion of the work to be performed by anyone other than the original subcontractor listed in the original bid, or (c) sublet or subcontract any portion of the work in excess of one-half of one percent of the Contractor's total bid where the original bid did not designate a subcontractor, except as authorized in the Subletting and Subcontracting Fair Practices Act.

Subletting or subcontracting of any portion of the work in excess of one-half of one percent of the Contractor's total bid where no subcontractor was designated in the original bid shall only be permitted in cases of public emergency or necessity, and then only after a finding, reduced to writing as a public record, of the authority awarding this Contract setting forth the facts constituting the emergency or necessity.

All subcontractors (of any tier) performing any portion of the Work must comply with the Labor Code sections 1725.5 and 1771.1 and must be properly and currently registered with the California Department of Industrial Relations and qualified to perform public works pursuant to Labor Code section 1725.5 throughout the duration of the Project.

NOTE: If alternate bids are called for and bidder intends to use different or additional subcontractors on the alternates, a separate list of subcontractors must be provided for each such Alternate.

DESIGNATION OF SUBCONTRACTORS FORM

| Scope of Work | Name of Subcontractor | Location & Place of Business | License Type and Number | DIR Registration Number | <i>E-Mail & Telephone*</i> |
|----------------------|------------------------------|---|--------------------------------|--------------------------------|---------------------------------------|
| | | | | | |
| | | | | | |
| | | | | | |
| | | | | | |
| | | | | | |
| | | | | | |
| | | | | | |
| | | | | | |
| | | | | | |

| Scope of Work | Name of Subcontractor | Location & Place of Business | License Type and Number | DIR Registration Number | <i>E-Mail & Telephone*</i> |
|---------------|-----------------------|------------------------------|-------------------------|-------------------------|--------------------------------|
| | | | | | |
| | | | | | |
| | | | | | |

* This information must be provided at the time of submission of bid or must be provided within 24 hours after the time set for the opening of bids. Bidders who choose to provide this information within 24 hours after the time set for the opening of bids are solely responsible to ensure the District receives this information in a timely manner. The District is not responsible for any problems or delays associated with emails, faxes, delivery, etc. Absent a verified fax or email receipt date and time by the District, the District's determination of whether the information was received timely shall govern and be determinative. Bidder shall not revise or amend any other information in this form submitted at the time of bid. The information submitted at the time of bid shall govern over any conflicts, discrepancies, ambiguities or other differences in any subsequent Subcontractor Designation Forms submitted by the bidder.

Proper Name of Bidder: _____
Date: _____
Name: _____
Signature of Bidder _____
Representative: _____
Address: _____
Phone: _____

BID FORM

FOR

**Liberty High School Stadium Improvements
850 Second Street, Brentwood, CA 94513**

Project No. 1722.00

Bid No. U1809L

FOR

LIBERTY UNION HIGH SCHOOL DISTRICT

CONTRACTOR
NAME:

ADDRESS:

TELEPHONE:

()

FAX:

()

EMAIL

TO: Liberty Union High School District, acting by and through its Governing Board, herein called "District".

1. Pursuant to and in compliance with your Notice Inviting Bids and other documents relating thereto, the undersigned bidder, having familiarized himself with the terms of the Contract, the local conditions affecting the performance of the Contract, the cost of the work at the place where the work is to be done, with the Drawings and Specifications, and other Contract Documents, hereby proposes and agrees to perform within the time stipulated, the Contract, including all of its component parts, and everything required to be performed, including its acceptance by the District, and to provide and furnish any and all labor, materials, tools, expendable equipment, and utility and transportation services necessary to perform the Contract and complete all of the Work in a workmanlike manner required in connection with the construction of:

LIBERTY HIGH SCHOOL STADIUM IMPROVEMENTS (as described below):

Project will provide a new pre-engineered 2,200 seating capacity home bleacher and press box. A new single-story Fitness Building will be provided underneath the new bleacher. The Fitness Building is approximately 4,170 square feet and consists of a Weight Room, Team Room, Toilet Rooms and Storage Rooms. The Fitness Building is construction Type 5-A and Occupancy Type E, and will be protected automatic fire sprinkler system. Adjacent site development will include four exterior basketball courts and fenced exterior storage areas.

Project will provide a new Concession Building and Stadium Entry Plaza. The single-story Concession Building is approximately 2,300 square feet and primary spaces include a Concession area, bulk Storage Room, Girls Toilet Room, Boys Toilet Room, and a Ticket Window room. The building is of Type 5-B construction and Occupancy Type B. The building will not be provided automatic fire sprinkler system.

Project will include providing a pad and utility service to a District provided pre-manufactured portable Toilet Building at the northeast corner of the football field. The Toilet Building is approximately 480 square feet (12'x40').

New site work will include a new Stadium Entry plaza with concrete paving and landscaping. The existing student parking lots will be adjusted to allow for the entry plaza with new perimeter parking stalls.

For the:

LIBERTY HIGH SCHOOL STADIUM IMPROVEMENTS

BID SCHEDULE NO. U1809L

Liberty High School Stadium Improvements

in the District described above, all in strict conformance with the drawings and other Contract Documents on file at the Facilities Office of said District for amounts set forth herein.

2. BIDDER ACKNOWLEDGES THE FOLLOWING BID CLARIFICATION OR ADDENDUM:

| | | | | | | | |
|--------|--------|--------|--------|--------|--------|--------|--------|
| Number | Number | Number | Number | Number | Number | Number | Number |
| _____ | _____ | _____ | _____ | _____ | _____ | _____ | _____ |

Liberty High School Stadium Improvements
Liberty Union High School District

Bid Set
Page 19

Acknowledge the inclusion of all addenda issued prior to bid in the blanks provided above. Your failure to do so may render your bid non-responsive.

3. TOTAL CASH PURCHASE PRICE IN WORDS & NUMBERS:

_____ DOLLARS
(\$ _____)

4. TIME FOR COMPLETION: The District may give a notice to proceed within ninety (90) days of the award of the bid by the District. Once the Contractor has received the notice to proceed, the Contractor shall complete the work in the time specified in the Agreement. By submitting this bid, Contractor has thoroughly studied this Project and agrees that the Contract Time for this Project is adequate for the timely and proper completion of the Project. Further, Contractor has included in the analysis of the time required for this Project, Rain Days, Governmental Delays, and the requisite time to complete Punch List.

In the event that the District desires to postpone giving the notice to proceed beyond this ninety (90) day period, it is expressly understood that with reasonable notice to the Contractor, giving the notice to proceed may be postponed by the District. It is further expressly understood by the Contractor, that the Contractor shall not be entitled to any claim of additional compensation as a result of the postponement of giving the notice to proceed.

If the Contractor believes that a postponement will cause a hardship to it, the Contractor may terminate the contract with written notice to the District within ten (10) days after receipt by the Contractor of the District's notice of postponement. Should the Contractor terminate the Contract as a result of a notice of postponement, the District shall have the authority to award the Contract to the next lowest responsible bidder, if applicable.

It is understood that the District reserves the right to reject any or all bids and/or waive any irregularities or informalities in this bid or in the bid process. The Contractor understands that it may not withdraw this bid for a period of ninety (90) days after the date set for the opening of bids.

5. Attached is bid security in the amount of not less than ten percent (10%) of the bid:

Bid bond (10% of the Bid), certified check, or cashier's check (circle one)

6. The required List of Designated Subcontractors is attached hereto.

7. The required Non-Collusion Declaration is attached hereto.

8. The Substitution Request Form, if applicable, is attached hereto.

9. It is understood and agreed that if written notice of the acceptance of this bid is mailed, telegraphed, or delivered to the undersigned after the opening of the bid, and within the time this bid is required to remain open, or at any time thereafter before this bid is withdrawn, the undersigned will execute and deliver to the District a Contract in the form attached hereto in accordance with the bid as accepted, and that he or she will also furnish and deliver to the District the Performance Bond and Payment Bond, all within five (5) calendar days after award of Contract, and that the work under the Contract shall be commenced by the undersigned bidder, if awarded the Contract, by the start date provided in the District's Notice to Proceed, and shall be completed by the Contractor in the time specified in the Contract Documents.

10. The names of all persons interested in the foregoing proposal as principals are as follows:

(IMPORTANT NOTICE: If bidder or other interested person is a corporation, state the legal name of such corporation, as well as the names of the president, secretary, treasurer, and manager thereof; if a co-partnership, state the true names of the firm, as well as the names of all individual co-partners comprising the firm; if bidder or other interested person is an individual, state the first and last names in full.)

11. PROTEST PROCEDURES. If there is a bid protest, the grounds shall be submitted as set forth in the Instructions to Bidders.

12. The undersigned bidder shall be licensed and shall provide the following California Contractor's license information:

License Number: _____

License Expiration Date: _____

Name on License: _____

Class of License: _____

DIR Registration Number: _____

If the bidder is a joint venture, each member of the joint venture must include the above information.

13. Time is of the essence regarding this Contract, therefore, in the event the bidder to whom the Contract is awarded fails or refuses to post the required bonds and return executed copies of the Agreement form within five (5) calendar days from the date of receiving the Notice of Award, the District may declare the bidder's bid deposit or bond forfeited as damages.

14. The bidder declares that he/she has carefully examined the location of the proposed Project, that he/she has examined the Contract Documents, including the Plans, General Conditions, Supplemental Conditions, Addenda, and Specifications, all others documents and requirements that are attached to and/or contained in the Project Manual, all other documents issued to bidders and read the accompanying instructions to bidders, and hereby proposes and agrees, if this proposal is accepted, to furnish all materials and do all work required to complete the said work in accordance with the Contract Documents, in the time and manner therein prescribed for the unit cost and lump sum amounts set forth in this Bid Form.

15. DEBARMENT. In addition to seeking remedies for False Claims under Government Code section 12650 et seq. and Penal Code section 72, the District may debar a Contractor pursuant to Article 15 of the

General Conditions if the Board, or the Board may designate a hearing officer who, in his or her discretion, finds the Contractor has done any of the following:

- a. Intentionally or with reckless disregard, violated any term of a contract with the District;
- b. Committed an act or omission which reflects on the Contractor's quality, fitness or capacity to perform work for the District;
- c. Committed an act or offense which indicates a lack of business integrity or business honesty; or
- d. Made or submitted a false claim against the District or any other public entity. (See Government Code section 12650, et seq., and Penal Code section 72)

16. DESIGNATION OF SUBCONTRACTORS. In compliance with the Subletting and Subcontracting Fair Practices Act (California Public Contract Code section 4100 et seq.) and any amendments thereof, each bidder shall list subcontractors on the District's form Subcontractor list. This subcontractor list shall be submitted with the bid and is a required form

I agree to receive service of notices at the e-mail address listed below.

I the below-indicated bidder, declare under penalty of perjury that the information provided and representations made in this bid are true and correct.

Proper Name of Company

Name of Bidder Representative

Street Address

City, State, and Zip

()
Phone Number

()
Fax Number

E-Mail

By: _____ Date: _____
Signature of Bidder Representative

NOTE: If bidder is a corporation, the legal name of the corporation shall be set forth above together with the signature of authorized officers or agents and the document shall bear the corporate seal; if bidder is a partnership, the true name of the firm shall be set forth above, together with the signature of the partner or partners authorized to sign contracts on behalf of the partnership; and if bidder is an individual, his signature shall be placed above.

All signatures must be made in permanent blue ink.

CONTRACTOR'S CERTIFICATE REGARDING WORKERS' COMPENSATION
FORM

Labor Code section 3700 in relevant part provides:

Every employer except the State shall secure the payment of compensation in one or more of the following ways:

1. By being insured against liability to pay compensation by one or more insurers duly authorized to write compensation insurance in this State.
2. By securing from the Director of Industrial Relations a certificate of consent to self-insure, which may be given upon furnishing proof satisfactory to the Director of Industrial Relations of ability to self-insure and to pay any compensation that may become due to employees.
3. For any county, city, city and county, municipal corporation, public district, public agency, or any political subdivision of the state, including each member of a pooling arrangement under a joint exercise of powers agreement (but not the state itself), by securing from the Director of Industrial Relations a certificate of consent to self-insure against workers' compensation claims, which certificate may be given upon furnishing proof satisfactory to the director of ability to administer workers' compensation claims properly, and to pay workers' compensation claims that may become due to its employees. On or before March 31, 1979, a political subdivision of the state which, on December 31, 1978, was uninsured for its liability to pay compensation, shall file a properly completed and executed application for a certificate of consent to self-insure against workers' compensation claims. The certificate shall be issued and be subject to the provisions of Section 3702.

I am aware of the provisions of Labor Code section 3700 which require every employer to be insured against liability for workers' compensation or to undertake self-insurance in accordance with the provisions of that code, and I will comply with such provision before commencing the performance of the work of this Contract.

(Signature)

(Print)

(Date)

In accordance with Article 5 (commencing at section 1860), Chapter 1, Part 7, Division 2 of the Labor Code, the above certificate must be signed and submitted with the Contractor's bid.

NON-COLLUSION DECLARATION

The undersigned declares:

I am the _____ [Title] of _____ [Name of Company], the party making the foregoing bid.

The bid is not made in the interest of, or on behalf of, any undisclosed person, partnership, company, association, organization, or corporation. The bid is genuine and not collusive or sham. The bidder has not directly or indirectly induced or solicited any other bidder to put in a false or sham bid. The bidder has not directly or indirectly colluded, conspired, connived, or agreed with any bidder or anyone else to put in a sham bid, or to refrain from bidding. The bidder has not in any manner, directly or indirectly, sought by agreement, communication, or conference with anyone to fix the bid price of the bidder or any other bidder, or to fix any overhead, profit, or cost element of the bid price, or of that of any other bidder. All statements contained in the bid are true. The bidder has not, directly or indirectly, submitted his or her bid price or any breakdown thereof, or the contents thereof, or divulged information or data relative thereto, to any corporation, partnership, company, association, organization, bid depository, or to any member or agent thereof, to effectuate a collusive or sham bid, and has not paid, and will not pay, any person or entity for such purpose.

Any person executing this declaration on behalf of a bidder that is a corporation, partnership, joint venture, limited liability company, limited liability partnership, or any other entity, hereby represents that he or she has full power to execute, and does execute, this declaration on behalf of the bidder.

I declare under penalty of perjury under the laws of the State of California that the foregoing is true and correct and that this declaration is executed on _____ [Date], at _____ [City], _____ [State].

Signed: _____

Typed Name: _____

BID GUARANTEE FORM

(Use only when not using a Bid Bond)

Accompanying this proposal is a cashier's check payable to the order of the Liberty Union High School District or a certified check payable to the order of the Liberty Union High School District in an amount equal to ten percent (10%) of the base bid and alternates (\$_____).

The proceeds of this check shall become the property of said District, if, this proposal shall be accepted by the District through the District's Governing Board, and the undersigned fails to execute a Contract with and furnish the sureties required by the District within the required time; otherwise, said check is to be returned to the undersigned.

Bidder

Note: Use this form, in lieu of Bid Bond form, when a cashier's check or certified check is accompanying the bid

BID BOND FORM

KNOW ALL MEN BY THESE PRESENT that we, the undersigned, (hereafter called "Principal"), and _____ (hereafter called "Surety"), are hereby held and firmly bound unto the Liberty Union High School District (hereafter called "District") in the sum of _____ (\$_____) for the payment of which, well and truly to be made, we hereby jointly and severally bind ourselves, successors, and assigns.

SIGNED this _____ day of _____, 20__.

The condition of the above obligation is such that whereas the Principal has submitted to the District a certain Bid, attached hereto and hereby made a part hereof, to enter into a Contract in _____ writing _____ for _____ the _____ construction _____ of _____.

NOW, THEREFORE,

- a. If said Bid is rejected, or
- b. If said Bid is accepted and the Principal executes and delivers a Contract or the attached Agreement form within five (5) calendar days after acceptance (properly completed in accordance with said Bid), and furnishes bonds for his faithful performance of said Contract and for payment of all persons performing labor or furnishing materials in connection therewith,

Then this obligation shall be void; otherwise, the same shall remain in force and effect.

Surety, for value received, hereby stipulates and agrees that no change, extension of time, alteration, or addition to the terms of the Contract, or the call for bids, or the work to be performed thereunder, or the specifications accompanying the same, shall in anyway affect its obligation under this bond, and it does hereby waive notice of any such change, extension of time, alteration, or addition to the terms of said Contract, or the call for bids, or the work, or to the specifications.

In the event suit is brought upon this bond by the District and judgment is recovered, the Surety shall pay all costs incurred by the District in such suit, including without limitation, attorneys' fees to be fixed by the court.

IN WITNESS WHEREOF, Principal and Surety have hereunto set their hands and seals, and such of them as are corporations have caused their corporate seals to be hereto affixed and these presents to be signed by their proper officers, on the day and year first set forth above.

(Corporate Seal)

By _____
Principal's Signature

Typed or Printed Name

Principal's Title

(Corporate Seal)

By _____
Surety's Signature

Typed or Printed Name

Title

(Attached Attorney in Fact Certificate)

Surety's Name

Surety's Address

Surety's Phone Number

IMPORTANT:

Surety companies executing bonds must possess a certificate of authority from the California Insurance Commissioner authorizing them to write surety insurance defined in California Insurance Code section 105, and if the work or project is financed, in whole or in part, with federal, grant, or loan funds, it must also appear on the Treasury Department's most current list (Circular 570 as amended).

THIS IS A REQUIRED FORM.

Any claims under this bond may be addressed to:

(Name and Address of Surety)

(Name and Address of agent or representative for service of process in California if different from above)

(Telephone Number of Surety and agent or representative for service of process in California).

ACKNOWLEDGMENT OF BIDDING PRACTICES REGARDING INDEMNITY FORM

TO: Liberty Union High School District

RE: Project Number _____

Construction Contract for _____

Please be advised that with respect to the above-referenced Project the undersigned Contractor on behalf of itself and all subcontractors hereby waives the benefits and protection of Labor Code section 3864, which provides:

“If an action as provided in this chapter is prosecuted by the employee, the employer, or both jointly against the third person results in judgment against such third person, the employer shall have no liability to reimburse or hold such third person harmless on such judgment or settlement in the absence of a written agreement to do so executed prior to the injury.”

This Agreement has been signed by an authorized representative of the contracting party and shall be binding upon its successors and assignees. The undersigned further agrees to promptly notify the District of any changes of ownership of the contracting party or any subcontractor while this Agreement is in force.

Contracting Party

Name of Agent/Title

DISABLED VETERAN BUSINESS ENTERPRISE (DVBE) PARTICIPATION
STATEMENT

Each bidder must complete this form in order to comply with the Liberty Union High School District ("District") policy for participation of disabled veteran business enterprises (School District projects funded in whole or in part by the State of California pursuant to the Leroy F. Greene School Facilities Act of 1998. (Education Code §17070.10, *et seq.*)

Project Name: _____

Bid No.: _____

DSA No.: _____

The undersigned, on behalf of the Contractor named below, certifies that the Contractor has made reasonable efforts to secure participation by DVBE in the Contract to be awarded for the above-referenced Bid No., including participation by DVBE subcontractors and/or material suppliers. **Check only one of the following:**

- The Contractor was unable after reasonable efforts to secure DVBE participation in the Contract for the above-referenced Project/Bid No. However, the Contractor will use DVBE services if the opportunity arises at any time during construction of the Project. Upon completion of the Project, the Contractor will report to the District the total dollar amount of DVBE participation in any Contract awarded to Contractor, and in any change orders, for the above-referenced Project.

- The Contractor has secured DVBE participation in the Contract for the above referenced Project/Bid No., and anticipates that such DVBE participation will equal approximately _____dollars (\$_____), which represents approximately _____percent (___%) of the total Contract for such Project. Upon completion of the Project, Contractor will report to the District the actual total dollar amount of DVBE participation in the Contract awarded to Contractor, and in any change orders, for such Project

Company: _____

Name: _____

Title: _____

Signature: _____

Date: _____

CONTRACTOR’S CERTIFICATE REGARDING DRUG-FREE WORKPLACE

This Drug-Free Workplace Certification form is required from all successful bidders pursuant to the requirements mandated by Government Code section 8350 et seq., the Drug-Free Workplace Act of 1990. The Drug-Free Workplace Act of 1990 requires that every person or organization awarded a contract or grant for the procurement of any property or service from any State agency must certify that it will provide a drug-free workplace by performing certain specified acts. In addition, the Act provides that each contract or grant awarded by a State agency may be subject to suspension of payments or termination of the contract or grant, and the Contractor or grantee may be subject to debarment from future contracting, if the contracting agency determines that specified acts have occurred.

Pursuant to Government Code section 8355, every person or organization awarded a contract or grant from a State agency shall certify that it will provide a drug-free workplace by doing all of the following:

1. Publishing a statement, notifying employees that the unlawful manufacture, distribution, dispensation, possession, or use of a controlled substance is prohibited in the person’s or organization’s workplace, and specifying actions which will be taken against employees for violations of the prohibition.
2. Establishing a drug-free awareness program to inform employees about all of the following:
 - a. The dangers of drug abuse in the workplace;
 - b. The person’s or organization’s policy of maintaining a drug-free workplace;
 - c. The availability of drug counseling, rehabilitation and employee-assistance programs; and
 - d. The penalties that may be imposed upon employees for drug abuse violations;
3. Requiring that each employee engaged in the performance of the contract or grant be given a copy of the statement required by subdivision (a) and that, as a condition of employment on the contract or grant, the employee agrees to abide by the terms of the statement.

I, the undersigned, agree to fulfill the terms and requirements of Government Code section 8355 listed above and will (a) publish a statement notifying employees concerning the prohibition of controlled substance at the workplace, (b) establish a drug-free awareness program, and (c) require each employee engaged in the performance of the contact be given a copy of the statement required by section 8355(a) and require such employee agree to abide by the terms of that statement.

I also understand that if the Liberty Union High School District determines that I have either (a) made a false certification herein, or (b) violated this certification by failing to carry out the requirements of Section 8355, that the contract awarded herein is subject to termination, suspension of payments, or both. I further understand that, should I violate the terms of the Drug-Free Workplace Act of 1990, I may be subject to debarment in accordance with the requirements of Section 8350 et seq.

I acknowledge that I am aware of the provisions of Government Code section 8350 et seq. and hereby certify that I will adhere to the requirements of the Drug-Free Workplace Act of 1990.

DATE: _____

By: _____
Signature

**CONTRACTOR’S CERTIFICATE REGARDING ALCOHOLIC BEVERAGE AND
TOBACCO-FREE CAMPUS POLICY**

The Contractor agrees that it will abide by and implement the District’s Alcoholic Beverage and Tobacco-Free Campus Policy, which prohibits the use of alcoholic beverages and tobacco products, of any kind and at any time, in District-owned or leased buildings, on DISTRICT property and in DISTRICT vehicles. The Contractor shall procure signs stating “ALCOHOLIC BEVERAGE AND TOBACCO USE IS PROHIBITED” and shall ensure that these signs are prominently displayed in all entrances to school property at all times.

DATE: _____

CONTRACTOR

By: _____

Signature

[End of Bid Documents to be Submitted with Bid]

AGREEMENT FORM

THIS AGREEMENT, entered into this ____ day of _____, 20__ in the County of Contra Costa of the State of California, by and between the Liberty Union High School District, hereinafter called the “District”, and _____, hereinafter called the “Contractor”.

WITNESSETH that the District and the Contractor for the consideration stated herein agree as follows:

ARTICLE 1 - SCOPE OF WORK: The Contractor shall furnish all labor, materials, equipment, tools, and utility and transportation services, and perform and complete all work required in connection with Liberty High School Stadium Improvement (“Project”) in strict accordance with the Contract Documents enumerated in Article 7 below. The Contractor shall be liable to the District for any damages arising as a result of a failure to comply with that obligation, and the Contractor shall not be excused with respect to any failure to so comply by an act or omission of the Architect, Engineer, Inspector, Division of the State Architect (DSA), or representative of any of them, unless such act or omission actually prevents the Contractor from fully complying with the Contract Documents and the Contractor protests, in accordance with the Contract Documents, that the act or omission is preventing the Contractor from fully complying with the Contract Documents. Such protest shall not be effective unless reduced to writing and filed with the District office within seven (7) days of the date of occurrence of such act or omission preventing the Contractor from fully complying with the Contract Documents.

ARTICLE 2 - TIME OF COMPLETION: The District may give notice to proceed within ninety (90) days of the award of the bid by the District. Once the Contractor has received a notice to proceed, the Contractor shall reach Substantial Completion (See Article 1.1.46) of the Work within one hundred seventy-one (171) calendar days from receipt of the Notice to Proceed. This shall be called Contract Time. (See Article 8.1.1). It is expressly understood that time is of the essence.

Contractor has thoroughly studied the Project and has satisfied itself that the time period for this Project was adequate for the timely and proper completion of the Project within each milestone and within the Contract time. Further, Contractor has included in the analysis of the time required for this Project, items set forth in General Conditions Article 8.3.2.1, Submittal Schedules, Rain Day Float, and Governmental Delay Float.

In the event that the District desires to postpone giving the notice to proceed beyond this ninety (90) day period, it is expressly understood that with reasonable notice to the Contractor, giving the notice to proceed may be postponed by the District. It is further expressly understood by the Contractor, that the Contractor shall not be entitled to any claim of additional compensation as a result of the District’s postponement of giving the notice to proceed.

If the Contractor believes that a postponement will cause hardship to it, the Contractor may terminate the Contract with written notice to the District within ten (10) days after receipt by the Contractor of the District’s notice of postponement. It is further understood by the Contractor that in the event that the Contractor terminates the Contract as a result of postponement by the District, the District shall only be obligated to pay the Contractor for the work performed by the Contractor at the time of notification of postponement. Should the Contractor terminate the Contract as a result of a notice of postponement, the District shall have the authority to award the Contract to the next lowest responsible bidder.

ARTICLE 3 - LIQUIDATED DAMAGES: It being impracticable and infeasible to determine the amount of actual damage, it is agreed that the Contractor will pay the District the sum of Two Thousand Dollars (\$2,000) per calendar day for each and every day of delay beyond the Contract Time set forth in Article 2 of this Agreement (inclusive of Milestones that are critical on the critical path or noted as critical to the District) as liquidated damages and not as a penalty or forfeiture. In the event Liquidated Damages are not paid, the Contractor further agrees that the District may deduct such amount thereof from any money due or that may become due the Contractor under the Contract (See Article 9.6 and 2.2 of the General Conditions).

ARTICLE 4 - CONTRACT PRICE: The District shall pay to the Contractor as full consideration for the faithful performance of the Contract, subject to any additions or deductions as provided in the Contract Documents, the sum of _____ DOLLARS (\$ _____), said sum being the total amount stipulated in the Bid Contractor submitted. Payment shall be made as set forth in the General Conditions.

Should any Change Order result in an increase in the Contract Price, the cost of such Change Order shall be agreed to in advance by the Contractor and the District, subject to the monetary limitations set forth in Public Contract Code section 20118.4. In the event that the Contractor proceeds with a Change in work without an agreement between the District and Contractor regarding the cost of a Change Order, the Contractor waives any Claim of additional compensation for such additional work.

ARTICLE 5 - HOLD HARMLESS AGREEMENT: Contractor shall defend, indemnify and hold harmless District, Architect, Inspector, the State of California and their officers, employees, agents and independent contractors from all liabilities, claims, actions, liens, judgments, demands, damages, losses, costs or expenses of any kind arising from death, personal injury, property damage or other cause based or asserted upon any act, omission, or breach connected with or arising from the progress of Work or performance of service under this Agreement or the Contract Documents. As part of this indemnity, Contractor shall protect and defend, at its own expense, District, Architect, Construction Manager, Inspector, the State of California and their officers, employees, agents and independent contractors from any legal action including attorney's fees or other proceeding based upon such act, omission, breach or as otherwise required by this Article.

Furthermore, Contractor agrees to and does hereby defend, indemnify and hold harmless District, Architect, Construction Manager, Inspector, the State of California and their officers, employees, agents and independent contractors from every claim or demand made, and every liability, loss, damage, expense or attorney's fees of any nature whatsoever, which may be incurred by reason of:

(a) Liability for (1) death or bodily injury to persons; (2) damage or injury to, loss (including theft), or loss of use of, any property; (3) any failure or alleged failure to comply with any provision of law or the Contract Documents; or (4) any other loss, damage or expense, sustained by any person, firm or corporation or in connection with the Work called for in this Agreement or the Contract Documents, except for liability resulting from the sole or active negligence, or the willful misconduct of the District.

(b) Any bodily injury to or death of persons or damage to property caused by any act, omission or breach of Contractor or any person, firm or corporation employed by Contractor, either directly or by independent contract, including all damages or injury to or death of persons, loss (including theft) or loss of use of any property, sustained by any person, firm or corporation, including the District, arising out of or in any way connected with Work covered by this Agreement or the Contract Documents, whether said injury or damage occurs either on or off District property, but not for any loss, injury, death or damages caused by the sole or active negligence or willful misconduct of the District.

(c) Any dispute between Contractor and Contractor's subcontractors/supplies/ Sureties, including, but not limited to, any failure or alleged failure of the Contractor (or any person hired or employed directly or indirectly by the Contractor) to pay any Subcontractor or Materialman of any tier or any other person employed in connection with the Work and/or filing of any stop notice or mechanic's lien claims.

(d) Any claims, allegations, penalties, assessments, or liabilities to the extent caused by the Contractor's failure or the failure of any Subcontractor of any tier, to fully comply with the DIR registration requirements under Labor Code section 1725.5 at all times during the performance of any Work on the Project and shall reimburse the District for any penalties assessed against the District arising from any failure by the Contractor or any Subcontractor of any tier from complying with Labor Code sections 1725.5 and 1771.1. Nothing in this paragraph, however, shall require the Contractor or any Subcontractor to be liable to the District or indemnify the District for any penalties caused by the District in accordance with Labor Code section 1773.3 (g).

Contractor, at its own expense, cost, and risk, shall defend any and all claims, actions, suits, or other proceedings that may be brought or instituted against the District, its officers, agents or employees, on account of or founded upon any cause, damage, or injury identified herein Article 5 and shall pay or satisfy any judgment that may be rendered against the District, its officers, agents or employees in any action, suit or other proceedings as a result thereof.

The Contractor's and Subcontractors' obligation to defend, indemnify and hold harmless the Owner, Architect, Inspector, the State of California and their officers, employees, agents and independent contractors hereunder shall include, without limitation, any and all claims, damages, and costs for the following: (1) any damages or injury to or death of any person, and damage or injury to, loss (including theft), or loss of use of, any property; (2) breach of any warranty, express or implied; (3) failure of the Contractor or Subcontractors to comply with any applicable governmental law, rule, regulation, or other requirement; (4) products installed in or used in connection with the Work; and (5) any claims of violation of the Americans with Disabilities Act ("ADA").

ARTICLE 6 - PROVISIONS REQUIRED BY LAW: Each and every provision of law and clause required to be inserted in this Contract shall be deemed to be inserted herein, and this Contract shall be read and enforced as though it were included herein, and if through mistake or otherwise any such provision is not inserted or is not inserted correctly, then upon application of either party the Contract shall forthwith be physically amended to make such insertion or correction.

ARTICLE 7 - COMPONENT PARTS OF THE CONTRACT: The Contract entered into by this Agreement consists of the following Contract Documents, all of which are component parts of the Contract as if herein set out in full or attached hereto.

Notice Inviting Bids
Instructions to Bidders
Designation of Subcontractors
Non-Collusion Declaration
Bid Guarantee Form
Bid Bond
Bid Form
Contractor's Certificate Regarding Worker's Compensation
Acknowledgment of Bidding Practices Regarding Indemnity

DVBE Participation Statement and Close-Out Forms
Agreement Form
Payment Bond
Performance Bond
Guarantee
Escrow Agreement for Security Deposit In Lieu of Retention
Workers' Compensation/Employers Liability Endorsement
General Liability Endorsement
Automobile Liability Endorsement
Contractor's Certificate Regarding Drug-Free Workplace
Contractor's Certificate Regarding Alcohol and Tobacco
Contractor's Certificate Regarding Background Checks
General Conditions
Supplementary and Special Conditions
Specifications
All Bid Clarifications and Addenda as Issued
Drawings/Plans
Substitution Request Form
Requirements, Reports and/or Documents in the Project Manual or Other Documents Issued to Bidders

All of the above named Contract Documents are intended to be complementary. Work required by one of the above named Contract Documents and not by others shall be done as if required by all.

ARTICLE 8 - PREVAILING WAGES: Wage rates for this Project shall be in accordance with the general prevailing rate of holiday and overtime work in the locality in which the work is to be performed for each craft, classification, or type of work needed to execute the Contract as determined by the Director of the Department of Industrial Relations. Copies of schedules of rates so determined by the Director of the Department of Industrial Relations are on file at the administrative office of the District and are also available from the Director of the Department of Industrial Relations. Monitoring and enforcement of the prevailing wage laws and related requirements will be performed by the Labor Commissioner/ Department of Labor Standards Enforcement (DLSE).

The following are hereby referenced and made a part of this Agreement and Contractor stipulates to the provisions contained therein.

1. Chapter 1 of Part 7 of Division 2 of the Labor Code (Section 1720 et seq.)
2. California Code of Regulations, Title 8, Chapter 8, Subchapters 3 through 6 (Section 16000 et seq.)

ARTICLE 9 - RECORD AUDIT: In accordance with Government Code section 8546.7 (and Davis Bacon, if applicable) and Article 13.11 of the General Conditions, records of both the District and the Contractor shall be subject to examination and audit for a period of five (5) years after a Final Retention Payment or the Recording of a Notice of Completion, whichever occurs first.

ARTICLE 10 - CONTRACTOR'S LICENSE: The Contractor must possess throughout the Project a Class A or B Contractor's License, issued by the State of California, which must be current and in good standing.

IN WITNESS WHEREOF, this Agreement has been duly executed by the above named parties, on the day and year first above written.

LIBERTY UNION HIGH SCHOOL DISTRICT:

CONTRACTOR:

Type or Printed Name

Typed or Printed Name

Title (Authorized Officers or Agents)

Title

Signature

Signature

Dated: _____

Dated: _____

(CORPORATE SEAL)

PAYMENT BOND

(CALIFORNIA PUBLIC WORK)

KNOW ALL MEN BY THESE PRESENTS:

THAT WHEREAS, the LIBERTY UNION HIGH SCHOOL DISTRICT (sometimes referred to hereinafter as "Obligee") has awarded to _____ (hereinafter designated as the "Principal" or "Contractor"), an agreement for the work described as follows: _____ (hereinafter referred to as the "Public Work"); and

WHEREAS, said Contractor is required to furnish a bond in connection with said Contract, and pursuant to California Civil Code section 9550;

NOW, THEREFORE, We, _____, the undersigned Contractor, as Principal; and _____, a corporation organized and existing under the laws of the State of _____, and duly authorized to transact business under the laws of the State of California, as Surety, are held and firmly bound unto the LIBERTY UNION HIGH SCHOOL DISTRICT and to any and all persons, companies, or corporations entitled by law to file stop notices under California Civil Code section 9100, or any person, company, or corporation entitled to make a claim on this bond, in the sum of _____ Dollars (\$ _____), such sum being not less than one hundred percent (100%) of the total amount payable by said Obligee under the terms of said Contract, for which payment will and truly to be made, we bind ourselves, our heirs, executors and administrators, successors and assigns, jointly and severally, firmly by these presents.

THE CONDITION OF THIS OBLIGATION IS SUCH that if said Principal, its heirs, executors, administrators, successors, or assigns, or subcontractor, shall fail to pay any person or persons named in Civil Code section 9100; or fail to pay for any materials, provisions, or other supplies, used in, upon, for, or about the performance of the work contracted to be done, or for any work or labor thereon of any kind, or for amounts due under the Unemployment Insurance Code, with respect to work or labor thereon of any kind; or shall fail to deduct, withhold, and pay over to the Employment Development Department, any amounts required to be deducted, withheld, and paid over by Unemployment Insurance Code section 13020 with respect to work and labor thereon of any kind, then said Surety will pay for the same, in an amount not exceeding the amount herein above set forth, and in the event suit is brought upon this bond, also will pay such reasonable attorneys' fees as shall be fixed by the court, awarded and taxed as provided in California Civil Code section 9550 et seq.

This bond shall inure to the benefit of any person named in Civil Code section 9100 giving such person or his/her assigns a right of action in any suit brought upon this bond.

It is further stipulated and agreed that the Surety of this bond shall not be exonerated or released from the obligation of the bond by any change, extension of time for performance, addition, alteration or modification in, to, or of any contract, plans, or specifications, or agreement pertaining or relating to any scheme or work of improvement herein above described; or pertaining or relating to the furnishing of labor, materials, or equipment therefor; nor by any change or modification of any terms of payment or extension of time for payment pertaining or relating to any scheme or work of improvement herein above described; nor by any rescission or attempted rescission of the contract, agreement or bond; nor by any conditions

precedent or subsequent in the bond attempting to limit the right of recovery of claimants otherwise entitled to recover under any such contract or agreement or under the bond; nor by any fraud practiced by any person other than the claimant seeking to recover on the bond; and that this bond be construed most strongly against the Surety and in favor of all persons for whose benefit such bond is given; and under no circumstances shall the Surety be released from liability to those for whose benefit such bond has been given, by reason of any breach of contract between the Obligee and the Contractor or on the part of any obligee named in such bond; that the sole condition of recovery shall be that the claimant is a person described in California Civil Code section 9100, and who has not been paid the full amount of his or her claim; and that the Surety does hereby waive notice of any such change, extension of time, addition, alteration or modification herein mentioned.

IN WITNESS WHEREOF this instrument has been duly executed by the Principal and Surety above named, on the _____ day of _____, 20__.

PRINCIPAL/CONTRACTOR:

By: _____

SURETY:

By: _____

Attorney-in-Fact

IMPORTANT: THIS IS A REQUIRED FORM.

Surety companies executing bonds must possess a certificate of authority from the California Insurance Commissioner authorizing them to write surety insurance defined in California Insurance Code section 105, and if the work or project is financed, in whole or in part, with federal, grant or loan funds, Surety's name must also appear on the Treasury Department's most current list (Circular 570 as amended).

Any claims under this bond may be addressed to:

(Name and Address of Surety)

(Name and Address of agent or representative for service for service of process in California)

Telephone: _____

Telephone: _____

A notary public or other office completing this certificate verifies only the identity of the individual who signed the document to which this certificate is attached, and not the truthfulness, accuracy, or validity of that document.

STATE OF CALIFORNIA)

) ss.

COUNTY OF)

On _____, before me, _____, personally appeared _____, who proved on the basis of satisfactory evidence to be the person(s) whose name(s) is/are subscribed to the within instrument and acknowledged to me that he/she/they executed the same in his/her/their authorized capacity(ies) as the Attorney-in-Fact of _____ (Surety) and acknowledged to me that by his/her/their signature(s) on the instrument the person(s), or the entity upon behalf of which the person(s) executed the instrument.

I certify under PENALTY OF PERJURY under the laws of the State of California that the foregoing paragraph is true and correct.

WITNESS my hand and official seal.

Notary Public in and for said State

(SEAL)

Commission expires: _____

NOTE: A copy of the power-of-attorney to local representatives of the bonding company must be attached hereto.

PERFORMANCE BOND
(CALIFORNIA PUBLIC WORK)

KNOW ALL MEN BY THESE PRESENTS:

THAT WHEREAS, the LIBERTY UNION HIGH SCHOOL DISTRICT (sometimes referred to hereinafter as "Obligee") has awarded to _____ (hereinafter designated as the "Principal" or "Contractor"), an agreement for the work described as follows: _____ (hereinafter referred to as the "Public Work"); and

WHEREAS, the work to be performed by the Contractor is more particularly set forth in that certain contract for said Public Work dated _____, (hereinafter referred to as the "Contract"), which Contract is incorporated herein by this reference; and

WHEREAS, the Contractor is required by said Contract to perform the terms thereof and to provide a bond both for the performance and guaranty thereof.

NOW, THEREFORE, we, _____, the undersigned Contractor, as Principal, and _____, a corporation organized and existing under the laws of the State of _____, and duly authorized to transact business under the laws of the State of California, as Surety, are held and firmly bound unto the LIBERTY UNION HIGH SCHOOL DISTRICT in the sum of _____ Dollars (\$ _____), said sum being not less than one hundred percent (100%) of the total amount payable by said Obligee under the terms of said Contract, for which amount well and truly to be made, we bind ourselves, our heirs, executors, administrators, successors, and assigns, jointly and severally, firmly by these presents.

THE CONDITION OF THIS OBLIGATION IS SUCH THAT, if the bounded Contractor, his or her heirs, executors, administrators, successors or assigns, shall in all things stand to and abide by, and well and truly keep and perform the covenants, conditions, and agreements in said Contract and any alteration thereof made as therein provided, on his or her part, to be kept and performed at the time and in the manner therein specified, and in all respects according to their intent and meaning; and shall faithfully fulfill guarantees of all materials and workmanship; and indemnify, defend and save harmless the Obligee, its officers and agents, as stipulated in said Contract, then this obligation shall become null and void; otherwise it shall be and remain in full force and effect.

The Surety, for value received, hereby stipulates and agrees that it shall not be exonerated or released from the obligation of this bond (either by total exoneration or pro tanto) by any change, extension of time, alteration in or addition to the terms of the contract or to the work to be performed there under or the specifications accompanying the same, nor by any change or modification to any terms of payment or extension of time for any payment pertaining or relating to any scheme of work of improvement under the contract. Surety also stipulates and agrees that it shall not be exonerated or released from the obligation of this bond (either by total exoneration or pro tanto) by any overpayment or underpayment by the Obligee that is based upon estimates approved by the Architect. The Surety stipulates and agrees that none of the aforementioned changes, modifications, alterations, additions, extension of time or actions shall in any way affect its obligation on this bond, and it does hereby waive notice of any such changes, modifications,

alterations, additions or extension of time to the terms of the contract, or to the work, or the specifications as well notice of any other actions that result in the foregoing.

Whenever Principal shall be, and is declared by the Oblige to be, in default under the Contract, the Surety shall promptly either remedy the default, or shall promptly take over and complete the Contract through its agents or independent contractors, subject to acceptance and approval of such agents or independent contractors by Oblige as hereinafter set forth, in accordance with its terms and conditions and to pay and perform all obligations of Principal under the Contract, including, without limitation, all obligations with respect to warranties, guarantees and the payment of Liquidated Damages; or, at Oblige's sole discretion and election, Surety shall obtain a bid or bids for completing the Contract in accordance with its terms and conditions, and upon determination by Oblige of the lowest responsible bidder, arrange for a contract between such bidder and the Oblige and make available as Work progresses (even though there should be a default or succession of defaults under the contract or contracts of completion arranged under this paragraph) sufficient funds to pay the cost of completion less the "balance of the Contract Price" (as hereinafter defined), and to pay and perform all obligations of Principal under the Contract, including, without limitation, all obligations with respect to warranties, guarantees and the payment of Liquidated Damages. The term "balance of the Contract Price," as used in this paragraph, shall mean the total amount payable to Principal by the Oblige under the Contract and any modifications thereto, less the amount previously paid by the Oblige to the Principal, less any withholdings by the Oblige allowed under the Contract. Oblige shall not be required or obligated to accept a tender of a completion contractor from the Surety.

Surety expressly agrees that the Oblige may reject any agent or contractor which may be proposed by Surety in fulfillment of its obligations in the event of default by the Principal. Unless otherwise agreed by Oblige, in its sole discretion, Surety shall not utilize Principal in completing the Contract nor shall Surety accept a bid from Principal for completion of the work in the event of default by the Principal.

No final settlement between the Oblige and the Contractor shall abridge the right of any beneficiary hereunder, whose claim may be unsatisfied.

The Surety shall remain responsible and liable for all patent and latent defects that arise out of or relate to the Contractor's failure and/or inability to properly complete the Public Work as required by the Contract and the Contract Documents. The obligation of the Surety hereunder shall continue so long as any obligation of the Contractor remains.

Contractor and Surety agree that if the Oblige is required to engage the services of an attorney in connection with enforcement of the bond, Contractor and Surety shall pay Oblige's reasonable attorneys' fees incurred, with or without suit, in addition to the above sum.

In the event suit is brought upon this bond by the Oblige and judgment is recovered, the Surety shall pay all costs incurred by the Oblige in such suit, including reasonable attorneys' fees to be fixed by the Court.

IN WITNESS WHEREOF, we have hereunto set our hands and seals this ____ day of _____, 20__.

PRINCIPAL/CONTRACTOR:

By: _____

SURETY:

By: _____

Attorney-in-Fact

The rate of premium on this bond is _____ per thousand.

The total amount of premium charged: \$ _____ (This must be filled in by a corporate surety).

IMPORTANT: THIS IS A REQUIRED FORM.

Surety companies executing bonds must possess a certificate of authority from the California Insurance Commissioner authorizing them to write surety insurance defined in California Insurance Code section 105, and if the work or project is financed, in whole or in part, with federal, grant or loan funds, Surety's name must also appear on the Treasury Department's most current list (Circular 570 as amended).

Any claims under this bond may be addressed to:

(Name and Address of Surety)

(Name and Address of agent or representative for service for service of process in California)

Telephone: _____

Telephone: _____

GUARANTEE

Guarantee for _____ . We hereby guarantee that the _____, which we have installed in _____ has been done in accordance with the Contract Documents, including without limitation, the drawings and specifications, and that the work as installed will fulfill the requirements included in the bid documents. The undersigned and its surety agrees to repair or replace any or all such work, together with any other adjacent work, which may be displaced in connection with such replacement, that may prove to be defective in workmanship or material within a period of One (____1____) year from the date of the Notice of Completion of the above-mentioned structure by the Liberty Union High School District, ordinary wear and tear and unusual abuse or neglect excepted.

In the event the undersigned or its surety fails to comply with the above-mentioned conditions within a reasonable period of time, as determined by the District, but not later than ten (10) days after being notified in writing by the District or within forty eight (48) hours in the case of an emergency or urgent matter, the undersigned and its surety authorizes the District to proceed to have said defects repaired and made good at the expense of the undersigned and its surety, who will pay the costs and charges therefor upon demand. The undersigned and its surety shall be jointly and severally liable for any costs arising from the District's enforcement of this Guarantee.

Countersigned

(Proper Name)

(Proper Name)

By: _____

By: _____

(Signature of Subcontractor or Contractor)

(Signature of General Contractor if for Subcontractor)

Representatives to be contacted for service:

Name: _____

Address: _____

Phone Number: _____

ESCROW AGREEMENT FOR SECURITY DEPOSITS IN LIEU OF RETENTION

This Escrow Agreement is made and entered into by and between the Liberty Union High School District Oak Street, Brentwood, CA 94513 hereinafter called "Owner", and _____ whose address is _____, hereinafter called "Contractor", and _____ whose address is _____, hereinafter called "Escrow Agent".

For the consideration hereinafter set forth, the Owner, Contractor and Escrow Agent agree as follows:

1. Pursuant to Section 22300 of the Public Contract Code of the State of California, Contractor has the option to deposit securities with Escrow Agent as a substitute for Retention earnings required to be withheld by Owner pursuant to the Construction Contract entered into between the Owner and Contractor for _____ in the amount of _____ dated _____ (hereinafter referred to as the "Contract"). Alternatively, on written request of the Contractor, the Owner shall make payments of the Retention earnings directly to the escrow agent. When Contractor deposits the securities as a substitute for Contract earnings, the Escrow Agent shall notify the Owner within ten (10) days of deposit. The market value of the securities at the time of the substitution shall be at least equal to the cash amount then required to be withheld as Retention under the terms of the Contract between the Owner and Contractor. Securities shall be held in the name of the Owner, and shall designate the Contractor as beneficial owner.
2. The Owner shall make progress payments to the Contractor for such funds which otherwise would be withheld from progress payments pursuant to the Contract provisions, provided that the Escrow Agent holds securities in the form and amount specified above.
3. When the Owner makes payments of Retentions earned directly to the Escrow Agent, the Escrow Agent shall hold them for the benefit of the Contractor until such time as the escrow created under this Contract is terminated. The Contractor may direct the investment of the payments into securities. All terms and conditions of this Agreement and the rights and responsibilities of the parties shall be equally applicable and binding when the Owner pays the Escrow Agent directly.
4. Contractor shall be responsible for paying all fees for the expenses incurred by Escrow Agent in administering the Escrow Account and all expenses of the Owner. These expenses and payment terms shall be determined by the Owner, Contractor, and Escrow Agent.
5. The interest earned on the securities or the money market accounts held in escrow and all interest earned on that interest shall be for the sole account of Contractor and shall be subject to withdrawal by Contractor at any time and from time to time without notice to the Owner.
6. Contractor shall have the right to withdraw all or any part of the principal in the Escrow Account only by written notice to Escrow Agent accompanied by written authorization from the Owner to the Escrow Agent that Owner consents to the withdrawal of the amount sought to be withdrawn by Contractor.
7. The Owner shall have a right to draw upon the securities in the event of default by the Contractor. Upon seven (7) days' written notice to the Escrow Agent from the Owner of the notice of default under Article 2.2, Article 9.6 or Article 14, the Escrow Agent shall immediately convert the securities to cash and shall distribute the cash as instructed by the Owner.

8. Upon receipt of written notification from the Owner certifying that the Contract is final and complete, and that the Contractor has complied with all requirements and procedures applicable to the Contract, Escrow Agent shall release to Contractor all securities and interest on deposit less escrow fees and charges of the Escrow Account. The escrow shall be closed immediately upon disbursement of all moneys and securities on deposit and payment of fees and charges.

9. Escrow Agent shall rely on the written notifications from the Owner and the Contractor pursuant to Sections (5) to (8), inclusive, of this Agreement and the Owner and Contractor shall hold Escrow Agent harmless from Escrow Agent's release and disbursement of the securities and interest as set forth above.

10. The names of the persons who are authorized to give written notice or to receive written notice on behalf of the Owner and on behalf of Contractor in connection with the foregoing, and exemplars of their respective signatures are as follows:

On behalf of Owner:

Title

Name

Signature

Address

On behalf of Contractor:

Title

Name

Signature

Address

On behalf of Agent:

Title

Name

Signature

Address

At the time the Escrow Account is opened, the Owner and Contractor shall deliver to the Escrow Agent a fully executed counterpart of this Agreement.

IN WITNESS WHEREOF, the parties have executed this Agreement by their proper officers on the date set forth above.

OWNER

CONTRACTOR

Title

Title

Name

Name

Signature

Signature

INSURANCE DOCUMENTS & ENDORSEMENTS

The OCIP insurance documents and required endorsements must be provided to the Liberty Union High School District within five (5) calendar days after receipt of notification of award. If the apparent low bidder fails to provide the documents required below, the District may award the Contract to the next lowest responsible and responsive bidder or release all bidders, and the bidder's bid security will be forfeited. All insurance provided by the bidder shall fully comply with the requirements set forth in Article 11 of the General Conditions.

11. DISABLED VETERAN BUSINESS ENTERPRISE (DVBE) CONTRACTOR CLOSE-OUT STATEMENT

The Contractor shall complete this form, as a condition to Final Payment, for purposes of reporting participation by Disabled Veteran Business Enterprises (DVBE) in the Contract for the Project/Bid No. specified below.

Project Name: _____

Bid No.: _____

DSA No.: _____

| Name | Address/Phone | Category of Work* | \$ Amount of Contract |
|------|---------------|-------------------|-----------------------|
| | | | |
| | | | |
| | | | |
| | | | |
| | | | |

* Categories of work include: (1) construction services (specify services that DVBE will provide); (2) architecture and engineering services; (3) procurement of materials, supplies and equipment; and (4) information technology.

The undersigned, on behalf of the Contractor, certifies that DVBE participation on the Contract for Bid No. _____ equaled _____ dollars (\$ _____), which represents approximately _____ percent (____%) of the total Contract price including change orders for the Project.

Company: _____

Name: _____

Title: _____

Signature: _____

Date: _____

CONTRACTOR CERTIFICATION REGARDING BACKGROUND CHECKS

(Modernization Projects)

_____ certifies that it has performed one of the following:
[Name of contractor/consultant]

- Pursuant to Education Code section 45125.1, Contractor has conducted criminal background checks, through the California Department of Justice, of all employees providing services to the _____ District, pursuant to the contract/purchase order dated _____, and that none have been convicted of serious or violent felonies, as specified in Penal Code sections 1192.7(c) and 667.5(c), respectively.

As further required by Education Code section 45125.1, attached hereto as Attachment "A" is a list of the names of the employees of the undersigned who may come in contact with pupils.

OR

- Pursuant to Education Code section 45125.2, Contractor will ensure the safety of pupils by one or more of the following methods:
 - 1. The installation of a physical barrier at the worksite to limit contact with pupils.
 - 2. Continual supervision and monitoring of all employees of the entity by an employee of the entity whom the Department of Justice has ascertained has not been convicted of a violent or serious felony.

I declare under penalty of perjury under the laws of the United States that the foregoing is true and correct.

Date _____, 20__

[Name of Contractor/Consultant]

By its: _____

ATTACHMENT A:

CONTRACTOR CERTIFICATION REGARDING BACKGROUND CHECKS

(INSERT NAMES OF EMPLOYEES WHO MAY COME IN CONTACT WITH PUPILS)

GENERAL CONDITIONS

ARTICLE 1 DEFINITIONS

1.1 BASIC DEFINITIONS

NOTE: The following shall not be construed as a comprehensive list of all definitions in the Contract Documents and there may be other definitions set forth in the Contract Documents. Additionally, any references to any DSA forms, documents or requirements shall be construed to incorporate any updates, supplements, or additions. The Contractor shall be required to meet the latest DSA requirements applicable to the Project.

1.1.1 Action of the Governing Board is a vote of a majority of the District's Governing Board.

1.1.2 Approval means written authorization through action of the Governing Board. The Governing board has delegated to the Superintendent or Chief Business Officer the authority to approve certain modifications, Change Orders or Immediate Change Directives. In no case shall the Superintendent or Chief Business Officer have authority to approve total Change Orders or Modifications to the Project exceeding 10% of the Contract Sum.

1.1.3 Architect means the architect, engineer, or other design professional engaged by the District to design and perform general observation of the work of construction and interpret the Drawings and Specifications for the Project. (See ARTICLE 4)

1.1.4 As-Builts are a set of Plans and Specifications maintained by the Contractor clearly showing all changes, revisions, substitutions, field changes, final locations, and other significant features of the Project. The As-Builts shall be maintained continuously throughout the Work for the Project and is both a prerequisite to the issuance of Payment Application and a requirement for Contract Close-Out. (See Article ARTICLE 1)

1.1.5 Beneficial Occupancy is the point in time when a building or buildings are fit for occupancy is fit for occupancy and its intended use. Basic requirements are the building is safe, at or near Substantial Completion, and all fire/ life safety items are approved and operational. The fact that a building is occupied does not mean that the building is ready for Beneficial Occupancy if there are elements that are unsafe or if fire/ life safety items are not approved and operational. Taking occupancy on a structure that is under a fire watch is not considered beneficial occupancy. Further, taking of Beneficial Occupancy is not a point in time when retention is due unless the entire school has obtained a Certificate of Substantial Completion that meets the definition of 1.1.46.

1.1.6 Claims. A Claim is a request for payment, supported by back-up documentation which includes, invoices time sheets, or other documents substantiating legitimacy or entitlement that is submitted during the Project or immediately following the Project made prior to the Final Retention Payment Application and prior to Final Completion of the Project. A "Claim" means a separate demand by the Contractor for (1) time extension, (2) payment of money or damages arising from Work done by or on behalf of the Contractor pursuant to the CONTRACT and payment of which is not otherwise expressly provided for or the claimant is not otherwise entitled to, or (3) and amount the payment of which is disputed by the District. (See Article 4.6)

1.1.7 Change Order (CO). A CO is a written instrument prepared by the Architect and signed by the District (as authorized by the District's Governing Board), the Contractor, and the Architect, stating their agreement upon (1) A description of a change in the Work, (2) The amount of the adjustment in the Contract Sum, if any; and (3) The extent of the adjustment in the Contract Time, if any. (See Article 7.2)

GENERAL CONDITIONS

1.1.8 Change Order Request (COR). A COR is a written request supported by backup documentation prepared by the Contractor requesting that the District and the Architect issue a CO based upon a proposed change, or a change that results in an adjustment in cost, time or both, or arising from an RFP, CCD or ICD. (See Article 7.6)

1.1.9 Close-Out means the process for Final Completion of the Project, but also includes the requirements for the DSA Certification that the Project is Complete (See DSA Certification Guide). (See Article 9.9)

1.1.10 Construction Change Document (CCD). A Construction Change Document is a DSA term that is utilized to address changes to the DSA approved Plans and Specifications. There are two types of Construction Change Documents. (1) DSA approved CCD Category A for work affecting structural, access or fire/ life safety of the Project which will require a DSA approval; and, (2) CCD Category B for work NOT affecting structural safety, access compliance or fire/ life safety that will not require a DSA approval (except to confirm that no approval is required). Both CCD Category A and Category B shall be set forth in DSA Form 140 and submitted to DSA as required. (See Article 7.3)

1.1.11 Complete/ Completion/ Final Completion means that all Work in the Contract Documents is finished, the requirements of the Contract Documents have been met, the Project has been Closed Out, and all Work has ceased on the Project. This may also be referred to as Final Completion. In most cases, the recording of a Notice of Completion shall represent Completion of the Project. Beneficial Occupancy does not mean the Work is Complete.

1.1.12 Completion Date is the date when all Work for the Project shall be Substantially Complete and is the date assigned at the end of the Contract Time for the Project. (See Article 1.1.46)

1.1.13 Construction Manager. The Construction Manager is a consultant to the District contracted to assist in Project planning, management and construction of the Project. If there is a Construction Manager, they may assist in various aspects of the Project including, but not limited to Monitoring the progress of the construction, reviewing and monitoring the schedule, progress of work, monitoring pay requests, facilitating communications, advising the District and its Board of Education on various aspects of the construction process, monitoring the RFI, COR, CCD, ICD, RFP, Claims, Disputes and other Project related processes.

1.1.14 Contract or Agreement when the terms are used in these General Conditions shall be references to the Contract Documents as defined herein.

1.1.15 Contract Documents (sometimes referred to as Construction Documents) consist of the Agreement between District and Contractor (hereinafter the Agreement or Contract), Conditions of the Contract (General, Supplementary and other Conditions), Drawings, Specifications, Addenda issued prior to bid, instructions to bidders, notice to bidders, and the requirements contained in the Bid Documents, other documents listed in the Agreement, and Modifications issued after execution of the Contract. A Modification is a written amendment to the Contract signed by parties, a Change Order, a Construction Change Document, or a written order for a minor change in the Work issued by the Architect. The Contract Documents collectively form the Contract. The Contract represents the entire and integrated Agreement between the parties hereto and supersedes prior negotiations, representations, or agreements, either written or oral. The Contract may be amended or modified only by a written Modification. The Contract Documents shall not be construed to create a contractual relationship of any kind between the Architect and Contractor, between the District and any Subcontractor or Sub-subcontractor, or between any persons or entities other than the District and the Contractor. The Architect shall, however, be entitled to performance and enforcement of obligations under the Contract intended to facilitate performance of the Architect's duties.

GENERAL CONDITIONS

1.1.16 Contract Time is the time period specified in the Contract Documents in which the Project shall be completed. This is sometimes referred to a Contract Duration, or “time in which the Contractor has to complete the Project”. (See Article 8.1.1)

1.1.17 Contractor, District, and Architect are those mentioned as such in the Agreement. They are treated throughout the Contract Documents as if they are of singular number and neuter gender. Any reference to “Owner” shall mean “District” or Liberty Union High School District.

1.1.18 Cure is the act of remedying a material failure to perform under the terms of the Contract Documents during the time provided to correct Contractor’s Default. Specific time periods are provided to Cure and Correct a Contractor Default under Article 14 and for a Partial Default under Article 2.2 as well as elsewhere in the Contract Documents.

1.1.19 Days mean calendar days unless otherwise specifically stated.

1.1.20 Default is a material breach of Contract. A Termination for Cause under Article 14 is a declaration of Default of the Contract and shall act as a demand upon the Surety to perform under the terms of the Performance Bond. Partial Defaults may also be tendered to the Surety at District’s discretion. (See Article 2.2)

1.1.21 Dispute. A dispute is a disagreement on terms or conditions of the Project where the Contractor’s opinion of the Project, Payment, Change Order or Request for Proposal differs from that of the District or Architect. A dispute only rises to the level of a claim once the dispute is assembled with back-up documentation and presented for evaluation. (See Article 4.6)

1.1.22 District Representative is the person designated by the District to represent the District during the Construction for the Project. This District Representative shall have the delegated authority as further defined in Article 1.1.2. This District Representative may be an employee of the District who may have the delegated authority as set forth in Article 1.1.3, and may also include Construction Managers. In some cases, the District and its Board may be assisted by a Construction Manager. When a Construction Manager is assisting the District, the Contractor, Architect, and Inspector shall have a primary contact with the District’s Construction Manager who will advise the District.

1.1.23 Drawings/Plans are graphic and pictorial portions of the Contract Documents prepared for the Project and approved changes thereto, wherever located and whenever issued, showing the design, location, and scope of the Work, generally including Plans, elevations, sections, details, schedules, and diagrams as drawn or approved by the Architect. Sometimes Drawings will also be included in Addenda, Change Orders, and Specifications.

1.1.24 DSA is the Division of State Architect. DSA is the agency that provides design and construction oversight for K-12 Schools, Community Colleges, and State Funded Charter School Projects. DSA is the responsible agency for this Project and Contractor has submitted a bid for the Project since Contractor is familiar with Contractor’s responsibilities under the DSA requirements more thoroughly set forth at Title 24 of the California Code of Regulations. Contractor agrees to abide by the jurisdiction of DSA and shall construct the Project to conform with the approved Plans, Specifications, Addenda, and Change Orders (inclusive of approved CCD’s and ICD’s issued by the District pending CCD approval). See DSA website.

1.1.25 Emergency shall be defined as a sudden, unexpected occurrence, involving a clear and imminent threat to the continuation of school classes, a critical path delay that will result in not being able to occupy the school when students arrive to use the facility, danger from the facility or from outside the facility, Act of God, or

GENERAL CONDITIONS

other action which requires immediate action to prevent or mitigate loss of, or damage to, life, health, property, or essential public services.

1.1.26 Float the total number of days an activity may be extended or delayed without delaying the Completion Date shown in the schedule. Float will fall into three categories: (1) Rain Days; (2) Governmental Delays; and, (3) Project Float. (See Article 8.1.4)

1.1.27 Immediate Change Directive. (ICD) A written order prepared by the Architect and signed by the District and the Architect, directing a change in the Work where the Work must proceed immediately and stating a proposed basis for adjustment, if any, in the Contract Sum or Contract Time, or both. (See Article 7.3)

1.1.28 Inspector of Record (IOR)/ Project Inspector (PI) is the individual retained by the District in accordance with Title 24 of the California Code of Regulations and who will be assigned to the Project

1.1.29 Notice of Non-Compliance (DSA Form 154) is a document issued by the Inspector if there is a deviation from the DSA approved Plans, Specifications, and Change Orders. (See Article 7.1.2)

1.1.30 Payment Application or Certificate of Payment is the Contractor's certified representation of the actual level of Work performed on the Project. Payment Applications are sometimes also called "Certificate of Payment", "Request for Payment", "Payment Application", or similar terms, and shall follow the Schedule of Values that are approved by the Architect, Inspector and District. (See Article 9.3)

1.1.31 Project is the complete construction of the Work performed in accordance with the Contract Documents.

1.1.32 Project Manual is the volume assembled for the Work which may include, without limitation, the bidding requirements, sample forms, Conditions of the Contract, and Specifications.

1.1.33 Provide shall include "provide complete in place," that is "furnish and install complete."

1.1.34 Punch List/ Punch Item/ Incomplete Punch Item is a list of minor repair items, prepared after the issuance of a Certificate of Substantial Completion, by the Inspector and Architect of Work required in order to complete the Contract Documents and ensure compliance with the DSA Approved Plans so the Project may be Closed Out. Issuance of the Retention Payment is dependent of the proper completion of the Punch List. (See Article 9.9)

1.1.34.1 *Contractor's List of Punch Items* is a list of minor repair items the Contractor submits when the Contractor considers the Work Substantially Complete. Submission of this List of Incomplete Punch Items is the Contractor's representation that the Project is Substantially Complete. (See Article 9.9.1.1)

1.1.35 Request for Information (RFI) is a written request prepared by the Contractor requesting the Architect to provide additional information necessary to clarify or amplify an item which the Contractor believes is not clearly shown or called for in the Drawings or Specifications, or to address problems which have arisen under field conditions. (See Article 7.4)

1.1.36 Request for Proposal (RFP) is a written request prepared by the Architect (and/or CM) requesting the Contractor to submit to an estimate of the effect of a proposed change on the Contract Price and (if applicable) the Contract Time. (See Article 7.5)

GENERAL CONDITIONS

1.1.37 Safety Orders are those issued by any city, county, state or federal agency having jurisdiction over the Project.

1.1.38 Schedule is the Contractor's view of the practical way in which the Work will be accomplished. In this Agreement there is a requirement for a Baseline Schedule and regular Schedule Updates that show all Work to be completed during the Contract Time and shall include all items listed under Article 8.3.2.9. See Article 8 of the General Conditions.

1.1.39 Schedule of Values is a detailed breakdown of the Contract Price for each Project, building, Phase of Work or Site as determined by the District. This Schedule of Values shall adequately detail the price for the Work so Progress Payments Applications can be meaningfully reviewed by the Inspector, Architect of Record, Engineer of Record, and District. (See Article 9.2)

1.1.40 Separate Contracts are Contracts that the District may have with other Contractors, vendors, suppliers, or entities to perform Work on the Project. This may include, but is not limited to Multi-Prime Trade Contractors, furniture installers, testing agencies, clean-up contractors, or network or low voltage contractors. Contractor shall plan for certain other contractors that may also be working on the Project site and address these other contractors in Contractor's Schedule. (See Article 6)

1.1.41 Site refers to the grounds of the Project as defined in the Contract Documents and such adjacent lands as may be directly affected by the performance of the Work.

1.1.42 Specifications are that portion of the Contract Documents consisting of the written requirements for material, equipment, construction systems, instructions, quality assurance standards, workmanship, and performance of related services.

1.1.43 Standards, Rules, and Regulations referred to are recognized printed standards and shall be considered as one and a part of these Specifications within limits specified. Federal, state and local regulations are incorporated into the Contract Documents by reference.

1.1.44 Stop Work Order, or an Order to Comply, is issued when either (1) the Work proceeds without DSA approval; (2) the Work proceeds without a DSA Inspector of Record, or (3) where DSA determines that the Work is not being performed in accordance with applicable rules and regulations, and would compromise the structural integrity of the Project or would endanger lives. If a Stop Work Order is issued, the Work in the affected area shall cease until DSA withdraws the Stop Work Order. Pursuant to Education Code section 17307.5(b), the District shall not be held liable in any action filed against the District for any delays caused by compliance with the Stop Work Order

1.1.45 Subcontractor, as used herein, includes those having direct or indirect contracts with Contractor and ones who furnished labor, material or services for a special design according to Plans, Drawings, and Specifications of this Work.

1.1.46 Substantial Completion/ Substantially Complete(d) is not reached unless and until each of the following four (4) conditions have been met: (1) all contractually required items have been installed with the exception of only minor and Incomplete Punch List Items (See Article 9.9.1.2); (2) All Fire/Life Safety Systems have been installed, and are working and signed off on the DSA Form 152 Inspection Card, and all building systems including mechanical, electrical and plumbing are all functioning; (3) all other items DSA Form 152 Inspection Card for the Project have been approved and signed off; and (4) the Project is fit for occupancy and its intended use. For the purposes of this Contract, any references to Completion Date means Substantial Completion Date.

GENERAL CONDITIONS

1.1.47 Substitution is a change in product, material, equipment, or method of construction from those required by the Construction Documents proposed by the Contractor. For this Project, a Substitution is subject to the filing of a Construction Substitution Request Form during the time of bid and meeting the requirements of Article ARTICLE 1.

1.1.48 Supplementary Conditions/ Supplementary General Conditions/ Special Conditions are terms that are sometimes used interchangeably and refer to any additional requirements or changes to the General Conditions as noted.

1.1.49 Surety is the person, firm, or corporation that executes as a bid bond, Payment Bond or Performance Bond guarantor on the Contractor's Bid, Contractor's Performance on the Contract and Payment of the Contractor's Subcontractors, material suppliers, vendors and labor on the Project. The Surety is bound to the same extent as the Contractor is bound once a Default occurs. A default includes a Termination for Substantial Failure to Perform under Article 14, but also includes any breach of Contract and is subject to the requirements and responsibilities as set forth in the Performance Bond.

1.1.50 Work shall include all labor, materials, services and equipment necessary for the Contractor to fulfill all of its obligations pursuant to the Contract Documents. It shall include the initial obligation of any Contractor or Subcontractor who performs any portion of the Work, to visit the Site of the proposed Work (a continuing obligation after the commencement of the Work), to fully acquaint and familiarize itself with the conditions as they exist and the character of the operations to be carried out under the Contract Documents, and make such investigation as it may see fit so that it shall fully understand the facilities, physical conditions, and restrictions attending the Work under the Contract Documents. Each such Contractor and its Subcontractors shall also thoroughly examine and become familiar with the Drawings, Specifications, and associated Contract Documents and bid documents before preparing and submitting any bid.

1.1.51 Workers include laborers, workers, and mechanics.

1.2 EXECUTION, CORRELATION AND INTENT

1.2.1 Correlation and Intent

1.2.1.1 *Documents Complementary and Inclusive.* The Contract Documents are complementary and are intended to include all items required for the proper execution and completion of the Work. All Contract Documents form the Contractor's Contract with the District. Any item of Work mentioned in the Specifications and not shown on the Drawings, or shown on the Drawings and not mentioned in the Specifications, shall be provided by Contractor as if shown or mentioned in both. The Contractor is bound to provide the Work complete and is under a legal duty to carefully study Plans and schedule operations well ahead of time and identify inconsistencies with the Plans and Specifications and call such inconsistencies to the attention of the Architect or Registered Engineer through the Inspector under Section 4-343(b) of Title 24.

1.2.1.2 *Work to be Complete.* Contractor has thoroughly studied the Contract Documents and understands that the District contracted with Contractor to provide a complete Project which means complete systems and buildings. The entire set of Contract Documents shows a complete Project and Contractor agrees that there are multiple disciplines putting together a set of Contract Documents. Thus, if portions of a system are shown on some Drawings and not others, this does not mean the Contractor is to only provide part of a system. For example, if an air conditioning unit is shown on the mechanical Drawings, the plumbing for the air conditioning is shown on another Drawing, and the electrical shown on the electrical Drawings, the Contractor is to provide a complete and working air conditioning

GENERAL CONDITIONS

system. The only time when an item is supplied incomplete is if the system is shown specifically as incomplete since others will be completing the system. Work includes, but is not limited to materials, workmanship, and manufacture of fabrication of components for the Project.

1.2.1.3 *Coverage of the Drawings and Specifications.* The Drawings and Specifications generally describe the Work to be performed by Contractor. Generally, the Specifications describe Work which cannot be readily indicated on the Drawings and indicate types, qualities, and methods of installation of the various materials and equipment required for the Work. It is not intended to mention every item of Work in the Specifications, which can be adequately shown on the Drawings, or to show on the Drawings all items of Work described or required by the Specifications even if they are of such nature that they could have been shown. All materials or labor for Work, which is shown on either the Drawings or the Specifications (or is reasonably inferable therefrom as being necessary to complete the Work), shall be provided by the Contractor. The Contractor is responsible for the whole Project as contractually set forth as the Contract Documents. It is intended that the Work be of sound, quality construction, and the Contractor shall be responsible for the inclusion of adequate amounts to cover installation of all items indicated, described, or implied in the portion of the Work to be performed by them.

1.2.1.4 *Conflicts.* In the event there is a discrepancy between the various Contract Documents, it is intended that the more stringent, higher quality, and greater quantity of Work shall apply.

1.2.1.5 *Conformance with Laws.* Each and every provision of law required by law to be inserted in this Contract shall be deemed to be inserted herein, and the Contract shall be read and enforced as though it were included herein, even if through mistake or otherwise any such provision is not inserted, or is not correctly inserted.

Before commencing any portion of the Work, Contractor shall check and review the Drawings and Specifications for such portion for conformance and compliance with all laws, ordinances, codes, rules and regulations of all governmental authorities and public and municipal utilities affecting the construction and operation of the physical plant of the Project, all quasi-governmental and other regulations affecting the construction and operation of the physical plant of the Project, and other special requirements, if any, designated in the Contract Documents. Such checking shall include review of Title 24 of the California Code of Regulations, California Building Code, local utility, local water connection, local grading and all other applicable agencies. In the event Contractor observes any violation of any law, ordinance, code, rule or regulation, or inconsistency with the Contract Documents, Contractor shall, within five (5) days, notify the Inspector, Architect and District in writing of same and shall ensure that any such violation or inconsistency shall be corrected in the manner provided hereunder prior to the construction of that portion of the Project. (See Title 24 Section 4-343)

The Contractor shall bear all expenses of correcting Work done contrary to said laws, ordinances, rules, and regulations if the Contractor performed same (1) without first consulting the Architect for further instructions regarding said Work or (2) disregarded the Architect's instructions regarding said Work.

1.2.1.6 *Ambiguity and Inconsistency.* Before commencing any portion of the Work, Contractor shall carefully examine all Drawings and Specifications and other information given to Contractor as to materials and methods of construction and other Project requirements. Prior to commencing any portion of the Work, Contractor shall notify Architect and District in writing of any perceived or alleged error, inconsistency, conflict, ambiguity, or lack of detail or explanation in the Drawings and Specifications in the manner provided herein. If the Contractor or its Subcontractors, material or equipment suppliers, or any of their officers, agents, and employees performs, permits, or causes

GENERAL CONDITIONS

the performance of any Work under the Contract Documents, which it knows or should have known to be in error, inconsistent, or ambiguous, or not sufficiently detailed or explained, Contractor shall bear any and all costs arising therefrom including, without limitation, the cost of correction thereof without increase or adjustment to the Contract Price or the time for performance. Contractor shall maintain an adequate inspection system and perform personal observations and review work and pre-plan the project to ensure the Work performed under the Contract conforms to Contract requirements. Contractor shall maintain records of such review and observation to ensure strict compliance with the terms of the Contract.

1.2.1.7 *Typical Parts and Sections.* Whenever typical parts or sections of the Work are completely detailed on the Drawings, and other parts or sections which are of the same construction are shown in outline only, the complete or more detailed shall apply to the Work which is shown in outline.

1.2.1.8 *Dimensions.* Dimensions of Work shall not be determined by scale or rule. Figured dimensions shall be followed at all times. If figured dimensions are lacking on Drawings, Architect shall supply them on request. The Architect's decisions on matters relating to aesthetic effect will be final.

1.2.2 Bid Clarifications, Addenda and Deferred Approvals

1.2.2.1 *Bid Clarifications and Addenda* are the changes in Specifications, Drawings, Contract Documents, and Plans which have been authorized in writing by the District or Architect, and which alter, explain, or clarify the Contract Documents. Addenda shall govern over all other Contract Documents. Subsequent addenda issued shall govern over prior addenda unless otherwise specified in the addenda.

1.2.2.2 *Deferred Approvals.* Deferred Approvals are Submittals that are reviewed by the Architect (or Engineer of Record) and submitted to DSA for approval based on thorough detailing of manufacturer and Project specific design. See Article ARTICLE 1 and ARTICLE 1. The Deferred Approval item cannot be fully detailed on the originally approved Drawings or Specifications because of variations in product design and manufacture. Contract Documents which require Deferred Approval items are meant to be for illustration purposes only. Approval of Plans for such a portion of the Work may be deferred until the material suppliers and Subcontractors are selected. All Deferred Approvals are noted in the Plans and Specifications. Contractor is responsible for all Deferred Approval requirements set forth in the Contract Documents. Contractor is responsible to comply with all laws, building codes, Title 24 and regulations necessary to obtain all necessary approvals, including those required from the Division of the State Architect ("DSA") and the State Fire Marshall. Contractor shall not be granted an extension of time for failure to plan, schedule for and obtain necessary approvals. Contractor shall Schedule all Deferred Approval items in the Baseline Schedule and Schedule Updates under Article ARTICLE 1

1.2.3 Specification Interpretation

1.2.3.1 *Titles.* The Specifications are separated into titled sections for convenience only and not to dictate or determine the trade or craft involved.

1.2.3.2 *As Shown, Etc.* Where "as shown," "as indicated," "as detailed," or words of similar import are used, reference is made to the Drawings accompanying the Specifications unless otherwise stated. Where "as directed," "as required," "as permitted," "as authorized," "as accepted," "as selected," or words of similar import are used, the direction, requirement, permission, authorization, approval, acceptance, or selection by Architect is intended unless otherwise stated.

GENERAL CONDITIONS

1.2.3.3 *General Conditions.* The General Conditions and Supplementary General Conditions are a part of the Contract Documents which further defines and refines the Contract entered between the Contractor and District.

1.2.3.4 *Abbreviations.* In the interest of brevity, the Specifications are written in an abbreviated form and may not include complete sentences. Omission of words or phrases such as “Contractor shall,” “shall be,” etc., are intentional. Nevertheless, the requirements of the Specifications are mandatory. Omitted words or phrases shall be supplied by inference in the same manner as they are when a “note” occurs on the Drawings. In the interest of brevity, the Contract Documents frequently omit modifying words such as “all” and “any” and articles such as “the” and “an,” but the fact that a modifier or an article is absent from one statement and appears in another is not intended to affect the interpretation of either statement.

1.2.3.5 *Plural.* Words in the singular shall include the plural whenever applicable or the context so indicates.

1.2.3.6 *Metric.* The Specifications may indicate metric units of measurement as a supplement to U.S. customary units. When indicated thus: 1” (25 mm), the U. S. customary unit is specific, and the metric unit is nonspecific. When not shown with parentheses, the unit is specific. The metric units correspond to the “International System of Units” (SI) and generally follow ASTM E 380, “Standard for Metric Practice.”

1.2.3.7 *Standard Specifications.* Any reference to standard specifications of any society, institute, association, or governmental authority is a reference to the organization’s standard specifications, which are in effect at the date of the Contractor’s proposal unless directed otherwise. If applicable specifications are revised prior to completion of any part of the Work, the Contractor may, if acceptable to Architect, perform such Work in accordance with the revised specifications. The standard specifications, except as modified in the Specifications for the Project, shall have full force and effect as though printed in the Specifications. Architect will furnish, upon request, information as to how copies of the standard specifications referred to may be obtained.

1.2.4 Rules of Document Interpretation

1.2.4.1 In the event of conflict within the Drawings, the following rules shall apply:

- a. General Notes, when identified as such, shall be incorporated into other portions of Drawings.
- b. Schedules, when identified as such, are complementary with other notes and other portions of Drawings including those identified as General Notes.
- c. Larger scale Drawings shall take precedence over smaller scale Drawings.
- d. At no time shall the Contractor base construction on scaled Drawings.

1.2.4.2 Specifications shall govern as to materials, workmanship, and installation procedures.

GENERAL CONDITIONS

1.2.4.3 If Contractor observes that Drawings and Specifications are in conflict, Contractor shall, prior to commencing work, notify the Architect in writing for the purposes of obtaining an interpretation of the Contract Documents.

1.2.4.4 In the case of conflict or inconsistencies, the order of precedence shall be as follows:

- a. General Conditions take precedence over Drawings and Specifications.
- b. Supplemental Conditions take precedence over General Conditions.
- c. The Agreement Form shall take precedence over the Supplemental Conditions.
- d. In the case of disagreement or conflict between or within Specifications, and Drawings, the more stringent, higher quality, and greater quantity of Work shall apply.
- e. Addenda shall take precedence over Drawings and Specifications.
- f. General Conditions shall take precedence over Addenda.
- g. Drawings and Specifications take precedence over the Soils Report.

1.3 **OWNERSHIP AND USE OF ARCHITECT'S DRAWINGS, SPECIFICATIONS AND OTHER DOCUMENTS**

The Drawings, Specifications, and other Contract Documents for the Project are the property of the District and/or Architect pursuant Contract requirements between the District and Architect. The Contractor may retain one Contract record set. Neither the Contractor nor any Subcontractor, or material or equipment supplier shall own or claim a Copyright in the Drawings, Specifications, and other documents prepared by the Architect. All copies except the Contractor's record set, shall be returned or properly accounted for upon completion of the Work. The Drawings, Specifications, and other documents prepared by the Architect, and copies thereof furnished to the Contractor are not to be used by the Contractor or any Subcontractor, Sub-subcontractor, or material or equipment supplier on other projects or for additions to this Project outside the scope of the Work. The District and/or Architect hereby grants the Contractor, Subcontractors, Sub-subcontractors, and material or equipment suppliers a limited license to use applicable portions of the Drawings, Specifications, and other documents prepared for the Project in the execution of their Work under the Contract Documents. Submittal or distribution to meet official regulatory requirements or for other purposes in connection with this Project is not to be construed as publication in derogation of the District's property interest or other reserved right.

GENERAL CONDITIONS

ARTICLE 2 DISTRICT

2.1 INFORMATION AND SERVICES REQUIRED OF THE DISTRICT

2.1.1 Site Survey

The District will furnish, at its expense, a legal description of the Site and a land survey showing the boundaries of the Site. Contractor shall be responsible for all surveys regarding location of construction, grading and site work.

2.1.2 Soils

When required by the scope of the Project, the District will furnish, at its expense, the services of geotechnical engineers or consultants when reasonably required and deemed necessary by the Architect or as required by local or state codes. Such services, with written reports and appropriate written professional recommendations, may include test boring, test pits, soil bearing values, percolation tests, air and water pollution tests, and ground corrosion and resistivity tests, including necessary operations for determining subsoil, air, and water conditions.

2.1.3 Soils Report Part of the Contract Documents: Contractor Reliance

A soils investigation report has been obtained from test holes at the Site, and such report is incorporated into this Contract and made available for the Contractor's use in preparing its bid and Work under this Contract. Where the Plans and Specifications are more specific and provide more significant structure, systems, reinforcing, thicknesses, or construction methods, the Drawings shall control over the soils report. The soils report is available at the Architect's office for review and it is Contractor's responsibility to ensure that Contractor has reviewed the soils investigation report. Any information obtained from such report or any other information given on Drawings as to subsurface soil condition or to elevations of existing grades or elevations of underlying rock is approximate only. If, during the course of Work under this Contract, Contractor encounters subsurface conditions which differ materially from those indicated in the soils report, then Contractor shall notify the District within five (5) calendar days of discovery of the condition, and changes to the Contract Price may be made in accordance with Article 7 entitled "Changes in the Work." Contractor agrees that no claim against District will be made by Contractor for damages and hereby waives any rights to damages in the event the Contractor fails to notify District within the five-day period mentioned above.

WARNING: DISTRICT DOES NOT WARRANT THE SOILS AT THE PROJECT SITE. CONTRACTOR HAS REVIEWED AND IS FAMILIAR WITH THE REQUIREMENTS OF THE SOILS INVESTIGATION REPORT. CONTRACTOR UNDERSTANDS THAT PLANS, DRAWINGS AND SPECIFICATIONS SUPERSEDE THE SOILS REPORT IF THERE ARE CONFLICTS. FURTHER, IN ADDITION TO THE INFORMATION IN THE SOILS REPORT, CONTRACTOR HAS CONDUCTED AN INDEPENDENT INVESTIGATION OF THE PROJECT SITE AND THE SOILS CONDITIONS OF THE SITE. DISTRICT DOES NOT WARRANT THE SOILS CONDITIONS OF THE SITE AND CONTRACTOR IS FULLY RESPONSIBLE TO ASCERTAIN SITE CONDITIONS FOR THE PURPOSES OF DETERMINING CONSTRUCTION MEANS AND METHODS PRIOR TO COMMENCING CONSTRUCTION.

GENERAL CONDITIONS

2.1.4 Utilities

2.1.4.1 *Location of Point of Connection.* The locations shown for the point of connection are approximate. It shall be the responsibility of the Contractor to determine the exact location of all service connections.

2.1.4.2 *Regional Notification Center.* Contractor, except in an emergency, shall contact the appropriate regional notification center at least two (2) business days prior to commencing any excavation if the excavation will be conducted in an area or in a private easement which is known, or reasonably should be known, to contain subsurface installations other than the underground facilities owned or operated by the District, and obtain an inquiry identification number from that notification center. See Government Code section 4216.3. No excavation shall be commenced and carried out by the Contractor unless such an inquiry identification number has been assigned to the Contractor or any Subcontractor of the Contractor and the District has been given the identification number by the Contractor. Any damages arising from failure to make appropriate regional notification shall be at the sole risk of Contractor. Contractor shall solely be responsible for any fines, penalties or damages for violation of this Article and Government Code section 4216.6 or 4216.7. Any delays caused by failure to make appropriate regional notification shall be at the sole risk of Contractor and shall not be considered for extension of time pursuant to Article 8.4.

2.1.4.3 *Utilities - Removal and Restoration.* The District has endeavored to determine the existence of utilities at the Site of the Work from the records of the District of known utilities in the vicinity of the Work. The positions of these utilities as derived from such records are shown in the Contract Documents. Thus, the locations of the main or trunklines located on the Drawings are approximate locations and not exact.

No excavations were made to verify the locations shown for underground utilities. Other than the main or trunkline, which the District has endeavored to locate on the Plans, service connections or laterals to these utilities may not be shown on the Plans. It shall be the responsibility of the Contractor to determine the exact location of all service connections. The Contractor shall make its own investigations, including exploratory excavations, to determine the locations and type of service connections, prior to commencing work which could result in damage to such utilities. The Contractor shall immediately notify the District's representative as to any utility main or trunkline discovered by Contractor in a different position than provided by the Regional Notification Center. With respect to main or trunklines, Contractor is to immediately notify District if the location is substantially different than as shown in the Contract Documents.

Contractor shall coordinate its Work with all utilities, including, but not limited to electricity, water, gas and telephone and meet with said utilities prior to the start of any work. Contractor shall show timing of all utility coordination activities under the Scheduling requirements of Article 8.

2.1.4.4 *Other Utilities.* In case it should be necessary to remove, relocate, or temporarily maintain a utility because of interference with the Work, the work on the utility shall be performed and paid for as follows:

When it is necessary to remove, relocate or temporarily maintain a service connection, the cost of which is not required to be borne by the owner of the service connection, the Contractor shall bear all expenses incidental to the work on the service connection. The work on the service connection shall be done in a manner satisfactory to the owner thereof; it being understood that the owner

GENERAL CONDITIONS

of the service connection has the option of doing such work with his own forces or permitting the work to be done by the Contractor.

When it is necessary to remove, relocate, or temporarily maintain a utility which is in the position shown on the Plans, the cost of which is not required to be borne by the owner thereof, the Contractor shall bear all expenses incidental to the work on the utility. The work on the utility shall be done in a manner satisfactory to the owner thereof; it being understood that the owner of the utility has the option of doing such work with his own forces or permitting the work to be done by the Contractor.

When it is necessary to remove, relocate, or temporarily maintain a utility which is not shown on the Plans or is in a position different from that shown on the Plans and were it in the position shown on the Plans would not need to be removed, relocated, or temporarily maintained, and the cost of which is not required to be borne by the owner thereof, the District will make arrangements with the owner of the utility for such work to be done at no cost to the Contractor, or will require the Contractor to do such work in accordance with Article 7 or will make changes in the alignment and grade of the Work to obviate the necessity to remove, relocate, or temporarily maintain the utility. Changes in alignment and grade will be ordered in accordance with Article 7 herein.

No representations are made that the obligations to move or temporarily maintain any utility and to pay the cost thereof is or is not required to be borne by the owner of such utility, and it shall be the responsibility of the Contractor to investigate to find out whether said cost is required to be borne by the owner of the utility.

The right is reserved to governmental agencies and to owners of utilities to enter at any time upon any street, alley, right-of-way, or easement for the purpose of making changes in their property made necessary by the Work and for the purpose of maintaining and making repairs to their property.

2.1.5 Existing Utility Lines; Removal, Relocation

2.1.5.1 *Main or Trunkline Facilities.* If the Contractor while performing the Contract discovers utility facilities not identified in the Contract Documents, Contractor shall notify the District and utility in writing prior to commencing work.

The owner of the public utility shall have the sole discretion to perform repairs or relocation work or permit the Contractor to do such repairs or relocation work at a reasonable price.

The Contractor shall exercise reasonable care and shall be compensated by the District for the actual verified field costs of locating, and removing, relocating, protecting or temporarily maintaining such main or trunkline utility facilities located in a substantially different location than in the Plans and Specifications, and for equipment in use on the project necessarily idled during such work. This Work shall be performed in accordance with Article 7 of these General Conditions.

2.1.5.2 *Assessment.* Nothing in these subparagraphs shall be deemed to require the District to indicate the presence of existing service laterals or appurtenances whenever the presence of such utilities on the Site can be inferred from the presence of other visible facilities, such as buildings, or meter junction boxes on or adjacent to the Site and could be inferred from the Main or Trunkline shown on the Drawings.

GENERAL CONDITIONS

2.1.5.3 *Notification.* If the Contractor, while performing Work under this Contract, discovers utility facilities not identified by the District in the Contract Documents. Contractor shall, within five (5) days, notify the District and the utility in writing. If Contractor fails to notify the District within forty eight hours after discovery of any utility facilities not identified by District in the Contract Documents, Contractor waives all rights to be compensated for any extra Work or damages resulting from such discovered utilities.

2.1.6 Easements

District shall secure and pay for easements for permanent structures or permanent changes in existing facilities, if any, unless otherwise specified in the Contract Documents.

2.2 **DISTRICT'S RIGHT TO CARRY OUT THE WORK DUE TO PARTIAL DEFAULT IN A SPECIFIC SEGREGATED AREA OF WORK (48 HOUR NOTICE TO CURE AND CORRECT)**

If the Contractor Defaults or neglects to carry out the Work in accordance with the Contract Documents, the District may provide forty-eight (48) hour written notice to cure (a shorter period of time in the case of Emergency or a critical path delay as defined in Article 2.2.1) Contractor's Partial Default in a specific segregated area of work. The District's right to issue a Partial Default of the Contractor's Work and take over that segregated area of Work includes, but is not limited to:

1. Failure to supply adequate workers on the entire Project or any part thereof;
2. Failure to supply a sufficient quantity of materials;
3. Failure to perform any provision of this Contract;
4. Failure to comply with safety requirements, or due to Contractor is creation of an unsafe condition;
5. Cases of bona fide emergency;
6. Failure to order materials in a timely manner;
7. Failure to prepare Deferred Approval items or Shop Drawings in a timely manner;
8. Failure to comply with Contractor's Baseline or Update Schedule, meet critical Milestones which would result in a delay to the critical path, or delay the Contract Time;
9. Failure to comply with the Subletting and Subcontracting Fair Practices, Public Contract Code section 4100, et seq.
10. Failure to meet the requirements of the Americans with Disabilities Act;
11. Failure to complete Punch List work;
12. Failure to proceed on an Immediate Change Directive
13. Failure to correct a Notice of Deviation

GENERAL CONDITIONS

If during the forty eight (48) hour period, the Contractor fails to Cure and correct the deficiency noted in the 48 hour notice of Partial Default with diligence and promptness, the District may correct such deficiencies without prejudice to other remedies the District may have, including a Termination for Cause as set forth in Article 14. If there are inadequate funds remaining the Project balance or in the Retention Escrow to address at least 150% of the costs set forth in the Article 2.2 notice, the District may copy the Surety on the written notice of Partial Default. If a notice to the Surety is provided, except in the cases of emergency or critical path delay, the Surety has the option to take over and complete the Work described in the written notice if Surety personally delivers notice to District that it intends to perform such work. In the case where written notice has been provided, the District shall allow Surety seven (7) days to perform the Work.

2.2.1 Service of Notice of Partial Default with Right to Cure

A written notice of Partial Default and right to cure under Article 2.2 (“Article 2.2 Notice” or “Notice of Partial Default”) shall be served by e-mail (with a copy provided by regular mail) to the e-mail address provided on the Bid submitted and copied to the Project Superintendent.

2.2.2 Shortened Time for Partial Default in the Case of Emergencies.

In an Emergency situation, the District may correct any of the deficiencies described in Article 2.2 without prejudice to other remedies by providing service of written notice of Emergency requiring a shortened time for Partial Default specifying the time given to cure, if any.

2.2.3 Shortened Time for Partial Default in the Case of Critical Path Delay

In the case of critical path delay, the District may correct any of the deficiencies described in Article 2.2 without prejudice to other remedies providing service of written notice of critical path delay to the Contractor with a specific description of the critical path delay items noting the line item or area of Work that is on the critical path and prescribe the length of shortened time to cure, if any.

2.2.4 Written Notice of Partial Default to be Deducted by Deductive Change Order

The District shall have the right to determine the reasonable value of the Article 2.2 Partial Default Work, or if there is an actual value for the Work, shall use that value and issue a Deductive Change Orders under Article 7.7.4

GENERAL CONDITIONS

ARTICLE 3 THE CONTRACTOR

3.1 SUPERVISION AND CONSTRUCTION PROCEDURES

3.1.1 Contractor

The Contractor shall continually supervise and direct the Work using the Contractor's best skill and attention. The Contractor shall be solely responsible for and have control over construction means, methods, techniques, sequences, procedures; and shall coordinate all portions of the Work under the Contract, unless the Contract Documents give other specific instructions concerning these matters. The Contractor shall not perform the Work without utilizing the Contract Documents or, where required, approved Submittals, Shop Drawings, or samples for any such portion of the Work. If any of the Work is performed by contractors retained directly by the District, Contractor shall be responsible for the coordination and sequencing of the work of those other contractors so as to avoid any impact on the Project Schedule pursuant to the requirements of Article 6 and Article 8. Specific duties of the Contractor shall include those set out in Section 43 of Title 21 of the California Code of Regulations and Section 4-343 of Title 24 of the California Code of Regulations. These duties include, but are not limited to the following:

3.1.1.1 *Responsibilities.* It is the duty of the Contractor to complete the Work covered by his or her Contract in accordance with the approved Plans and Specifications. The Contractor in no way is relieved of any responsibility by the activities of the Architect, Engineer, Inspector or DSA in the performance of their duties.

3.1.1.2 *Performance of the Work.* The Contractor shall carefully study the approved Plans and Specifications and shall plan its schedule of operations well ahead of time. If at any time it is discovered that work is being done which is not in accordance with the approved Plans and Specifications, the Contractor shall correct the Work immediately.

3.1.2 Contractor Responsibility to Study the Plans and Specifications

All inconsistencies or timing or sequences which appear to be in error in the Plans and Specifications shall promptly be called to the attention of the Architect or, Engineer, for interpretation or correction. Local conditions which may affect the structure shall be brought to the Architect's attention at once. In no case, shall the instruction of the Architect be construed to cause work to be done which is not in conformity with the approved Plans, Specifications, change orders, construction change documents, and as required by law. (See Title 24, Section 4-343)

3.1.3 All Work Under the Direction of Inspector

Pursuant to Title 24 requirements, the Contractor shall not carry on Work except with the knowledge of the Inspector. (See Title 24 generally)

3.1.4 Contractor to Establish Timing and Protocol with Inspector

Contractor shall establish a protocol for requesting inspection with Inspector so as to not delay the Work and provide adequate time for the Inspector to perform inspection. If such a protocol is not established ahead of time, Inspector may utilize the time criteria set by Title 24 of 48 hours in advance of submitting form DSA 156 for each new area. DSA requirements under PR 13-01 specifically gives the

GENERAL CONDITIONS

Special Inspector fourteen (14) days to post to the DSA website. Contractor is responsible for delays and for failure to plan.

For some Projects, there may be a need to incrementally install certain assemblies. It is up to Contractor to identify areas and assemblies that may be constructed incrementally. Contractor must identify and establish incremental areas of construction and establish protocols with Inspector for DSA 152 approvals so they may be presented to DSA. (See PR-13 item 1.17 for further discussion)

3.1.5 Verified Reports

The Contractor shall make and submit to the office from time to time, verified reports as required in Title 24 Section 4-366. As part of the Close-Out of the Project (see Article 9.9), Contractor shall be required to execute a Form 6-C as required under Title 24 Sections 4-343.

Contractor shall fully comply with any and all reporting requirements of Education Code sections 17315, et seq., in the manner prescribed by Title 24, as applicable.

3.1.6 Contractor Responsibility

The Contractor shall be responsible to the District for acts and omissions of the Contractor's employees, Subcontractors, material and equipment suppliers, and their agents, employees, invitees, and other persons performing portions of the Work under direct or indirect contract with the Contractor or any of its Subcontractors.

3.1.7 Obligations not Changed by Architect's Actions

The Contractor shall not be relieved of obligations to perform the Work in accordance with the Contract Documents either by activities or duties of the Architect in the Architect's administration of the Contract or by tests, inspections, or approvals required or performed by persons other than the Contractor.

3.1.8 Acceptance/Approval of Work

The Contractor shall be responsible to determine when any completed portions of the Work already performed under this Contract or provided pursuant to Article 6 are suitable to receive subsequent Work thereon.

3.2 SUPERVISION

3.2.1 Full Time Supervision

Unless personally present on the Project site where the Work is being performed, the Contractor shall keep on the Work at all times during its progress a competent, English speaking construction Superintendent satisfactory to the District. The Superintendent shall be present on a full-time basis, shall be dedicated exclusively to the Project and shall not share superintendency duties with another project or job. The Superintendent shall not be replaced except with written consent of the District. The Superintendent shall represent the Contractor in its absence and shall be fully authorized to receive and fulfill any instruction from the Architect, the Inspector, the District or any other District Representative (including CM in the cases where the District has a CM representative). All Requests for Information shall be originated by the Superintendent and responses thereto shall be given to the Superintendent. No Work

GENERAL CONDITIONS

shall begin on any day by any Subcontractor or other person on the Project site until the Superintendent has arrived, or shall any Work continue during the day after the Superintendent has departed from the Project site. The Superintendent shall have authority to bind Contractor through the Superintendent's acts. The Superintendent shall represent the Contractor, and communications given to the Superintendent shall be binding on the Contractor. Before commencing the Work, Contractor shall give written notice to District (and CM representative) and Architect of the name and a Statement of Qualifications of such superintendent. Superintendent shall not be changed except with written consent of District, unless a superintendent proves to be unsatisfactory to Contractor and ceases to be in its employ, in which case, Contractor shall notify District and Architect in writing. Contractor shall provide a replacement superintendent approved by the District prior to performing additional work.

3.2.2 Staff

Notwithstanding other requirements of the Contract Documents, the Contractor and each Subcontractor shall: (1) furnish a competent and adequate staff as necessary for the proper administration, coordination, supervision, and superintendence of its portion of the Work; (2) organize the procurement of all materials and equipment so that the materials and equipment will be available at the time they are needed for the Work; and (3) keep an adequate force of skilled and fit workers on the job to complete the Work in accordance with all requirements of the Contract Documents.

3.2.3 Right to Remove

District shall have the right, but not the obligation, to require the removal from the Project of any superintendent, staff member, agent, or employee of any Contractor, Subcontractor, material or equipment supplier.

3.3 LABOR AND MATERIALS

3.3.1 Contractor to Provide

Unless otherwise provided in the Contract Documents, the Contractor shall provide and pay for labor, material, equipment, tools, construction equipment and machinery, water, heat, air conditioning, utilities, transportation, and other facilities, services and permits necessary for proper execution and completion of the Work whether temporary or permanent and whether or not incorporated or to be incorporated in the Work.

3.3.2 Quality

Unless otherwise specified, all materials and equipment to be permanently installed in the Project shall be new and shall be of the highest quality or as specifically stated in the Contract Documents. The Contractor shall, if requested, furnish satisfactory evidence as to kind and quality of all materials and equipment within ten (10) days of a written request by the District, including furnishing the District with bona fide copies of invoices for materials or services provided on the Project. All labor shall be performed by workers skilled in their respective trades, and shall be of the same or higher quality as with the standards of other school construction.

3.3.3 Replacement

GENERAL CONDITIONS

Any work, materials, or equipment, which do not conform to these requirements or the standards set forth in the Contract Documents, may be disapproved by the District, in which case, they shall be removed and replaced by the Contractor at no additional cost or extension of time to the District.

3.3.4 Discipline

The Contractor shall enforce strict discipline and good order among the Contractor's and Subcontractor's employees, and other persons carrying out the Contract. The Contractor shall not permit employment of unfit persons or persons not skilled in tasks assigned to them. As used in this subsection, "unfit" includes any person who the District concludes is improperly skilled for the task assigned to that person, who fails to comply with the requirements of this article, or who creates safety hazards which jeopardize other persons and/or property.

3.3.5 Fingerprinting (Applicable at the time Project is Occupied and on all Projects where Workers will come in Contact with Pupils, such as Modernization Projects)

If applicable, Contractor shall comply with the applicable provisions of Education Code section 45125.1 in a method as determined by the District. Pursuant to Education Code section 45125.1, Contractor shall either conduct criminal background checks of all employees of Contractor assigned to the Project site, and shall certify that no employees who have been convicted of serious or violent felonies, as specified in Education Code section 45125.1, will have contact with pupils, by utilizing the Certification Regarding Background Checks and the corresponding Attachment "A" as found in the Contract Documents or shall be separated by a physical barrier from students.

If it is determined that Contractor must provide certification of employees, as part of such certification, Contractor must provide the District with a list of all employees providing services pursuant to this Agreement, and designate which sites such employees will be assigned. In performing the services set forth in this Agreement, Contractor shall not utilize any employees who are not included on the above-referenced list.

At District's sole discretion, District may make a finding, as authorized under Education Code section 45125.1, that Contractor's employees will have only "limited contact" with pupils. Contractor's failure to comply with this law shall be considered a material breach of this Agreement upon where this Agreement may be terminated, at District's sole discretion, without any further compensation to Contractor.

In the case of new construction Projects where there are no students, if the Project Schedule provides for Beneficial Occupancy or portions of the Project or if the Project should be delayed, then Contractor, at no additional costs, shall meet the requirements of either fingerprinting or providing a physical barrier as required by the District.

3.3.6 Noise, Drugs, Tobacco, and Alcohol

Contractor shall take all steps necessary to insure that employees of Contractor or any of its Subcontractors' employees do not use, consume, or work under the influence of any alcohol, tobacco or illegal drugs while on the Project. Contractor shall further prevent any of its employees or its Subcontractor employees from playing any recorded music devices or radios or wearing any radio headphone devices for entertainment while working on the Project. Likewise, Contractor shall prevent its employees or Subcontractor's employees from bringing any animal onto the Project. Contractors shall not violate any written school policies.

GENERAL CONDITIONS

3.3.7 Delivery of Material

Contractor shall place orders for materials or equipment so that the Work may be completed in accordance with the Construction schedule for the Work as set forth in Article 8 of this Agreement. Contractor shall, upon demand from the Architect, furnish to the Architect documentary evidence including, but not limited to purchase orders, invoices, bills of materials, work orders and bills of lading, showing that orders have been placed. Contractor shall have a system to receive materials and to ensure that the proper materials are being delivered, including in the case of critical materials to the Project, checking the delivery against Shop Drawings and ensuring that the materials meet the requirements of not only the Plans and Specifications, but also the approved Shop Drawings and Submittals and in conformance with Contractor's plan for delivery of materials (including but not limited to Contractor's representations in the Schedules for the Project and Contractor's equipment and materials schedule under Article ARTICLE 1). Contractor shall be responsible for all costs of accepting non-conforming materials delivered to the Project given Contractor's responsibilities and system for acceptance of deliveries. Contractor shall notify Inspector and District Representative (including CM) as early as possible, in writing, of the delivery of materials for the Project. The deliveries shall include documentation identifying the shipment sufficiently so that the Inspector, Architect or District Representative (including CM) may review the materials that are received. Under no circumstances shall materials be delivered to the Project site that are meant for another Project.

3.3.8 Liens and Other Security Interests of Subcontractors and Material Suppliers

No material, supplies, or equipment for the Work shall be purchased subject to any chattel mortgage or under a conditional sale or other agreement by which an interest therein or in any part thereof is retained by seller or supplier. Contractor warrants good title to all material, supplies, and equipment installed or incorporated in Work and agrees upon completion of all Work to deliver premises, together with all improvements and appurtenances constructed or placed thereon by it, to District free from any claims, security interests, liens, or charges. Contractor further agrees that neither it nor any person, firm, or corporation furnishing any materials or labor for any Work covered by this Contract shall have any right to place a lien upon the premises or any improvement or appurtenance thereof, except that Contractor may install metering devices or other equipment of a utility company or political subdivision, title to which is commonly retained by the utility company or political subdivision. In event of installation of any such metering device or equipment, Contractor shall advise District as to its owner within five (5) days of such installation in writing, prior to making the installation.

Contractor agrees to indemnify, defend and hold the District harmless from any liens, stop notices, or assertion of security interests, including judgments and levies. If after written notice Contractor fails to address the lien, stop notice, or other security interest, the District may proceed to address the lien, stop notice or claim and seek reimbursement from Contractor.

3.3.9 Title to Materials

The title to new materials or equipment for the Work of this Contract shall remain with Contractor until incorporated in the Work of this Contract until final acceptance of the Project; no part of said materials shall be removed from its place of storage, and Contractor shall keep an accurate inventory of all said materials and equipment in a manner satisfactory to the District or its authorized representative. Responsibility for materials remains with Contractor and Contractor shall replace materials in case of loss. District similarly may pay for materials stored off site, but Contractor shall remain responsible for the materials that are stored off site.

GENERAL CONDITIONS

3.3.10 Assemblies

For all material and equipment specified or indicated in the Drawings, the Contractor shall provide all labor, materials, equipment, and services necessary, (including engineering as specifically required with Shop Drawings or Deferred Approvals) for complete assemblies and complete working systems. Incidental items not indicated on the Drawings, nor mentioned in the Specifications, that can legitimately and reasonably be inferred to belong to the Work described, or be necessary in good practice to provide a complete assembly or system, shall be furnished as though itemized in the Contract Documents in every detail. In all instances, material and equipment shall be installed in strict accordance with each manufacturer's most recent published recommendations and Specifications.

3.3.11 Noise Control

The Contractor shall be responsible for the installation of noise reducing devices on construction equipment. Contractor shall comply with the requirements of the city and county having jurisdiction with regard to noise ordinances governing construction sites and activities. Construction equipment noise is subject to the control of the Environmental Protection Agency's Noise Control Program (Part 204 of Title 40, Code of Federal Regulations). If school is in session at any point during the progress of the Project, and, in the District's reasonable discretion, the noise from such Work disrupts or disturbs the students or faculty or the normal operation of the school, at the District's request, the Contractor shall schedule the performance of all such Work around normal school hours or make other arrangements so that the Work does not cause such disruption or disturbance. There are specific periods of testing at operational schools and it is critical that Contractor control noise during periods of testing. In no event shall Contractor have a right to receive additional compensation or an extension to the Contract time as a result of any such rescheduling or the making of such arrangements. These controls shall be implemented during site preparation and construction. All noise related issues, including school operations, and noise during testing should be detailed in the Schedule provided pursuant to Article 8

3.4 **WARRANTY**

The Contractor warrants to the District and Architect that material and equipment furnished under the Contract will be of the highest quality and new unless otherwise required or permitted by the Contract Documents, that the Work will be free from defects not inherent in the quality required or permitted, and that the Work will conform with the requirements of the Contract Documents. Work not conforming to these requirements, including substitutions not properly approved and authorized, may be considered defective. Contractor's warranty to District includes, but is not limited to, the following representations:

3.4.1 In addition to any other warranties provided elsewhere, Contractor shall, and hereby does, warrant all Work after the date of Notice of Completion of Work by District and shall repair or replace any or all such Work, together with any other Work, which may be displaced in so doing that may prove defective in workmanship or materials within a one (1) year period from date of Final Completion which shall be no later than the final date of Punch List as noted at Article 9.11) without expense whatsoever to District, ordinary wear and tear, unusual abuse or neglect excepted. District will give notice of observed defects with reasonable promptness. Contractor shall notify District upon completion of repairs.

3.4.2 In the event of failure of Contractor to comply with above mentioned conditions within one week after being notified in writing, District is hereby authorized to proceed to have defects repaired and made good at expense of Contractor who hereby agrees to pay costs and charges therefore immediately on demand.

GENERAL CONDITIONS

3.4.3 If, in the opinion of the District, defective Work creates a dangerous condition or requires immediate correction or attention to prevent further loss to the District, the District will attempt to give the notice required by this Article. If the Contractor cannot be contacted or does not comply with the District's requirements for correction within a reasonable time as determined by the District, the District may, notwithstanding the provisions of this article, proceed to make such correction or attention which shall be charged against Contractor. Such action by the District will not relieve the Contractor of the guarantee provided in this Article or elsewhere in this Contract.

3.4.4 This Article does not in any way limit the guarantee on any items for which a longer warranty is specified or on any items for which a manufacturer gives a guarantee for a longer period. Contractor shall furnish District all appropriate guarantee or warranty certificates upon completion of the project.

TAXES

Contractor will pay all applicable Federal, State, and local taxes on all materials, labor, or services furnished by it, and all taxes arising out of its operations under the Contract Documents. District is exempt from Federal Excise Tax, and a Certificate of Exemption shall be provided upon request.

PERMITS, FEES AND NOTICES

Payment

The Contractor shall secure and pay for all permits and governmental fees, licenses, and inspections necessary for proper execution and completion of the Work which are necessary after execution of the Contract and are legally required by any authority having jurisdiction over the Project, except those required by the Division of the State Architect (DSA). District shall be responsible for all testing and inspection as required by the DSA on-site or within the distance limitations set forth in Article 13.5.2, unless a different mileage range is specified in the Supplemental Conditions.

3.6.1.1 *DSA Fees.* DSA policy is to charge CCD review fees for processing and approval of changes in the Plans and Specifications through the Construction Change Document process. Contractor is specifically directed to the current DSA IR A-30 which provides fee structure and charges that will be incurred for proceeding with respect to the CCD process, a process that must be followed for each change in the Plans and Specifications.

Compliance

The Contractor shall comply with and give notices required by any law, ordinance, rule, regulation, and lawful order of public authorities bearing on performance of the Work. Specifically, the Division of State Architect provides State oversight of the Project and enforcement of Title 24 rules and regulations. Contractor is directed to the DSA website. There will be local governmental oversight from City, County or both. Finally, Regional Water Quality Control Board, State Fire Marshall, local fire marshal, Department of Industrial Relations, Department of Labor Standards Enforcement, and Air Quality Management District (Local and State) are some of the agencies that provide oversight and may require specific permits, fees, or provide oversight over the Project. Contractor represents understanding and specialized knowledge of the rules governing school districts and Contractor shall maintain compliance over the applicable rules and will file all documents required in order to ensure compliance with State, local, and other rules that apply to the Project.

Responsibility

GENERAL CONDITIONS

The Contractor shall perform all Work in conformance with every law, statute, ordinance, building code, rule or regulation. The Contractor shall assume full responsibility for such Work and shall bear the attributable cost of correction or project delay.

Pursuant to Title 24 Section 4-343(b):

“Contractor shall carefully study the approved Plans and Specifications and shall plan a schedule of operations well ahead of time.... All inconsistencies or items which appear to be in error in the Plans and Specifications shall be promptly called to the attention of the architect or registered engineer, through the inspector, for interpretation or correction.”

To help Contractor plan its operations, Contractor is directed to study the current version of the DSA 152 Inspection Card Manual identifying the exact steps the Inspector is to follow in the review and sign off process for the DSA 152. The DSA 152 Inspection Card Manual provides specific detail as to the order of operations, review items and compliance items beyond the Specifications and Plans which are reviewed for DSA compliance. The most current version of this manual is located on DSA’s website.

Contractor is also specifically directed to the time periods for posting of Special Inspection Reports and Inspector Notifications under DSA PR 13-01 since the timing of Inspection is not a Governmental Entity related delay.

3.7 SUBMITTALS REQUIRED AT THE COMMENCEMENT OF THE PROJECT

3.7.1 Requirements Within Ten (10) Calendar Days

Within ten (10) calendar days after Notice to Proceed, Contract shall submit the following:

- 3.7.1.1 Detailed Schedule of Values (See Article 9.2)
- 3.7.1.2 Submittal Listing and Schedule for Submittals
- 3.7.1.3 Critical Path Baseline Schedule (See Article 8)

3.7.2 Requirements Within Thirty-Five (35) Calendar Days

Within thirty-five (35) calendar days after Notice to Proceed, Contractor shall submit the following:

3.7.2.1 *All Submittals for the Project* except those specifically agreed upon by District and Architect, in writing, and shall be specifically incorporated into the Submittal section of the Schedule so as to not delay the Work. The agreement to allow a later Submittal does not mean that Article ARTICLE 1 is waived. Contractor shall order materials and ensure prices are honored and secured for the Project.

- a. Structural Steel may be included as a later Submittal than 35 days if Structural Steel is a significant portion of the Work, at least one or some of the Project is a structural steel structural system, or as specifically agreed upon by the Architect or District.

GENERAL CONDITIONS

- b. It is specifically agreed that submissions of structural steel Submittals shall not be piecemeal (unless some portion is requested separately by the District or Architect), shall provide complete designs, shall be stamped by the structural steel Subcontractor, Contractor, and structural steel Subcontractor's structural engineer at time of submission and as further addressed in Article ARTICLE 1.
- c. In no case shall the submission of structural steel Drawings delay the critical path for the schedule. If a Milestone is provided for submission of complete structural steel Shop Drawings then the date shall be no later than as set forth in the Milestone

3.7.2.2 *Exceptions to Submittal Within Thirty-Five (35) Days by Written Agreement.* A written request detailing the specific reasons for a submission later than 35 days due to complexity of design or non-critical path status of the Submittal shall be submitted at the time the Baseline Schedule is submitted. The Baseline Schedule shall not include a delayed Submittal until written agreement is provided. In addition to the request for providing a Submittal after the thirty-five (35) day period, a copy of the Contract with the Subcontractor who shall be performing the Submittal, a written statement from the Subcontractor verifying that work has commenced on the Submittal and providing Subcontractor's own schedule of Milestones and completion dates, and a corresponding Submittal designation in the Schedule as required under Article 8. Approval of a delayed Submittal shall not result in any increase in the Contract Price or result in an extension of time for the completion of the Project.

3.7.2.3 *Piecemeal Submissions of Submittals.* Piecemeal Submittals mean providing portions of Shop Drawings or Submittals as they are being completed. The submission of piecemeal Submittals results in the appearance of a submission when there is inadequate information for the Architect or Engineer to adequately review a submission. Piecemeal differs from submission of complete buildings or phases of buildings or complete assemblies. The Architect may agree to allow submission of single buildings or areas as long as the Submittals are complete. .

3.8 DOCUMENTS, SAMPLES, AND COMPUTER AT THE SITE

The Contractor shall maintain at the Site for the District one current copy of the California Building Code, Titles 19 and 24 of the California Code of Regulations, any other document required by DSA, and one record copy of the Drawings, Specifications, Addenda, Change Orders, and other Modifications, in good order and marked currently to record changes and selections made during construction. In addition, the Contractor shall maintain at the Site approved Shop Drawings, Product Data, Samples, and similar required Submittals. These documents shall be available to the Architect and shall be delivered to the Architect for delivery to the District upon completion of the Work.

Contractor shall have an operational computer with internet access so Contractor can review and post documents as required for the Project, including but not limited to the filing and posting of DSA required documents for the Project.

Contractor shall be prepared to review documents posted to the DSA Project website.

3.9 SUBMITTALS INCLUDING SHOP DRAWINGS, PRODUCT DATA, AND SAMPLES

3.9.1 Definitions

GENERAL CONDITIONS

3.9.1.1 *Deferred Approvals.* Approval of certain aspects of the construction may be deferred until the construction Contract has been awarded. To facilitate the design process, DSA grants Deferred Approval to the design and detailing of certain elements of the Project at the request of the Architect or Engineer of Record. Design elements that may be deferred may include, but are not limited to access floors, bleachers, elevator guide rails and related elevator systems, exterior wall systems - precast concrete, glass fiber reinforced concrete, etc., skylights, window wall systems, storefronts, stage rigging, and other systems as noted in the Contract Documents. (Also see Article 1.2.2.2 and ARTICLE 1)

3.9.1.2 *Shop Drawings.* The term “Shop Drawings” as used herein means Drawings, diagrams, equipment or product schedules, and other data, which are prepared by Contractor, Subcontractors, manufacturers, suppliers, or distributors illustrating some portion of the Work, and includes: illustrations; fabrication, erection, layout and setting Drawings; manufacturer’s standard Drawings; schedules; descriptive literature, instructions, catalogs, and brochures; performance and test data including charts; wiring and control diagrams; and all other Drawings and descriptive data pertaining to materials, equipment, piping, duct and conduit systems, and methods of construction as may be required to show that the materials, equipment, or systems and their position conform to the requirements of the Contract Documents.

3.9.1.3 *Manufactured* applies to standard units usually mass-produced, and “Fabricated” means items specifically assembled or made out of selected materials to meet individual design requirements. Shop Drawings shall: establish the actual detail of all manufactured or Fabricated items, indicate proper relation to adjoining work, amplify design details of mechanical and electrical systems and equipment in proper relation to physical spaces in the structure, and incorporate minor changes of design or construction to suit actual conditions.

3.9.1.4 *Submittals* is a term used interchangeably and sometimes refers to Shop Drawings, Product Data, and samples since all Subcontractor submissions are tracked in a Submittal Log and may include any of the noted items. However, generally, a Submittal is a manufacturer’s product information and Product Data including description, characteristics, size, physical characteristics, and requirements to prepare the jobsite for receiving of the particular manufactured item.

3.9.1.5 *Samples.* The term “samples” as used herein are physical examples furnished by Contractor to illustrate materials, equipment, or quality and includes natural materials, Fabricated items, equipment, devices, appliances, or parts thereof as called for in the Specifications, and any other samples as may be required by the Architect to determine whether the kind, quality, construction, finish, color, and other characteristics of the materials, etc., proposed by the Contractor conform to the required characteristics of the various parts of the Work. All Work shall be in accordance with the approved samples.

3.9.2 Shop Drawings.

3.9.2.1 *When Shop Drawings Are Required.* Shop Drawings are required for prefabricated components and for installation and coordination of these prefabricated components into the Project. In addition, Shop Drawings, are prepared to address the actual size and installation of components from various Subcontractors and provides an opportunity for the Contractor to coordinate and address conflicts between the subcontracting trades. In some cases, each Subcontractor or trade will provide Shop Drawings in a BIM format or other format as agreed by District.

3.9.2.2 *Purpose for Shop Drawings.* Shop Drawings are the Contractor’s manufacturer, Subcontractor, supplier, vendor or the Contractor’s detailed drawings showing particularized

GENERAL CONDITIONS

method for assembly, specifics to a manufacturer, manufacturer component installation requirements, specifics as to a manufactured item, alterations to a manufactured, a custom created item, or drawn version of more detailed information expanding on the Architect's design shown in the Contract Documents. The Shop Drawings address the appearance, performance, size, weight, characteristics and prescriptive descriptions associated with the Contractor or Contractor's Subcontractor's plan for installation or assembly based on the design in the Specifications and Contract Documents. The Shop Drawing often is more detailed than the information shown in the Contract Documents to give the Architect and Engineer the opportunity to review the fabricator's version of the product (along with particulars specific to that particular product), prior to fabrication. References to the Contract Documents, Construction Documents, Drawings, Plans, and Specifications assist the Architect and Engineer in their review of the Shop Drawings. Attachment of manufacturer's material Specifications, "catalog cut sheets," and other manufacturer's information may be provided to accompany Shop Drawings. Because Shop Drawings facilitate the Architect's and Engineer's approval of the system, they should be as clear and complete as possible so they may be reviewed by Architect or Engineer for the Project.

3.9.2.3 *Shop Drawing Requirements.* The Contractor shall obtain and submit with Shop Drawings all seismic and other calculations and all Product Data from equipment manufacturers. "Product Data" as used herein are illustrations, standard schedules, performance charts, instructions, brochures, diagrams, and other information furnished by the Contractor to illustrate a material, product, or system for some portion of the Work.

3.9.2.4 *Not a Reproduction of Architectural or Engineering Drawings.* The Shop Drawings are not a reproduction of the architectural or engineering Drawings. Instead, they must show more detail than the Construction Documents and details the fabrication and/or installation of the items to the manufacturer's production crew or Contractor's installation crews.

3.9.2.5 *Shop Drawings Engineering Requirements:* Some Shop Drawings require an engineer stamp to be affixed on the Drawings and calculations. In such cases, a current and valid engineering stamp shall be affixed by a California registered engineer. No out of State engineers shall stamp Shop Drawings. (See DSA IR A-18). In most cases, an engineer means California registered mechanical, structural, electrical or plumbing engineer. California Registered Civil Engineers will not be accepted for structural details unless specifically approved by DSA.

3.9.2.6 *DSA Approvals Required Prior to Work.* No work on a Shop Drawing that requires DSA approval may proceed until DSA approval is received. Contractor has provided DSA approval time and allowed adequate time for corrections in Contractor's Schedule as required pursuant to Article 8.

3.9.2.7 *Shop Drawing Identification.* All Shop Drawings must be properly identified with the name of the Project and dated, and accompanied by a letter of transmittal referring to the name of the Project and to the Specification section number for identification of each item clearly stating in narrative form, as well as "clouding" all qualifications, departures, or deviations from the Contract Documents. Shop Drawings, for each section of the Work shall be numbered consecutively and the numbering system shall be retained throughout all revisions. All Subcontractor submissions shall be made through the Contractor. Each drawing shall have a clear space for the stamps of Architect and Contractor.

3.9.3 Deferred Approvals

Deferred approvals shall be submitted and processed to ensure all DSA and other governmental approvals are secured so as to not delay the Project. There may be additional requirements

GENERAL CONDITIONS

for Deferred Approvals at Division 1 of the Specifications. All Deferred Approvals shall be prepared by Contractor or Contractor's agent early enough so as to not delay the Project. Contractor is aware that Title 24 California Code of Regulations Section 4-317 have specific requirements for Deferred Approval as to governing agencies and as to the Architect and Engineer for the Project. As a result, any delay associated with the time for approval by applicable agencies or by the Architect or Architect's consultants shall be Contractor's. Contractor is required to comply with inclusion of Deferred Approvals in the Schedule as required under Article *ARTICLE 1 DSA Approvals Required Prior to Work*. No work on a Deferred Approval item may proceed on the components until DSA approval is received. Contractor has provided DSA approval time and allowed adequate time for any DSA revisions in Contractor's Schedule as required pursuant to Article 8.

3.9.4 Submittals and Samples

3.9.4.1 *Information Required With Submittals:* Manufacturer, trade name, model or type number and quantities: Information provided must be of sufficient detail to allow Architect and Engineer to compare the submitted item with the specified products and acceptable products listed, in the Specifications and addenda.

3.9.4.2 *Description of Use and Performance Characteristics:* Information should be furnished describing the normal use and expected performance of the product. The Architect and Contractor review this information to confirm that the product is appropriate for the intended use.

3.9.4.3 *Size and Physical Characteristics:* The size and physical characteristics, such as adjustment capabilities, which is reviewed by both the Contractor and Architect. The Contractor has the most available information for comparing adjoining materials and equipment. The Contractor also needs to know the size and weight of the equipment for lifting and handling considerations.

3.9.4.4 *Finish Characteristics:* The Architect reviews the available finishes and selects the appropriate finish, if the finish was not previously specified in the documents. The Contractor should confirm that finish requirements in the Specifications are being met by the product.

3.9.4.5 *Contractor Responsible for Jobsite Dimensions:* Some material is custom-fabricated to job conditions, requiring dimensions from the jobsite. These jobsite dimensions are provided by the Contractor as part of the Contractor's responsibilities for the Project and shall be provided prior to release of the product for manufacture. Contractor shall not rely on Architect or Engineers to provide jobsite dimensions.

3.9.4.6 *Full Range of Samples Required (When Specific Items Not Specified).* Except in cases where the exact color and type of item is specified since the District is utilizing items Standardized or pre-selected by District, the full range of color, graining, texture, or other characteristics are anticipated for review in finished products, a sufficient number of samples of the specified materials shall be furnished by the Contractor to indicate the full range of characteristics which will be present in the finished products. Products delivered or erected without Submittal and approval without providing a full range of samples shall be subject to rejection. Except for range samples, and unless otherwise called for in the various sections of the Specifications or Specification Section 1, samples shall be submitted in duplicate.

3.9.4.7 *Labeling of Samples.* All samples shall be marked, tagged, or otherwise properly identified with the name of the submitting party, the name of the Project, the purpose for which the samples are submitted and the date.

GENERAL CONDITIONS

3.9.4.8 *Transmittal letter.* All samples shall be accompanied by a letter of transmittal containing similar information, together with the Specification section number.

3.9.4.9 *Labels and Instructions.* All samples of materials shall be supplied with the manufacturer's descriptive labels and application instructions. Each tag or sticker shall have clear space for the review stamps of Contractor and Architect.

3.9.4.10 *Architect's Review.* The Architect will review and, if appropriate, approve submissions and will return them to the Contractor with the Architect's stamp and signature applied thereto, indicating the timing for review and appropriate action in compliance with the Architect's (or District's) standard procedures. In the cases where a CM is hired by the District, CM may be the party that receives and performance logging and initial processing of the Samples. CM may, in some cases, reject samples that are not in conformance with Contract requirements.

3.9.5 Submittal Submission Procedure

3.9.5.1 *Transmittal Letter and Other Requirements.* All Submittals must be properly identified with the name of the Project and dated, and each lot submitted must be accompanied by a letter of transmittal referring to the name of the Project and to the Specification section number for identification of each item clearly stating in narrative form, as well as "clouding" on the submissions, all qualifications, departures, or deviations from the Contract Documents. Shop Drawings, for each section of the Work shall be numbered consecutively and the numbering system shall be retained throughout all revisions. All Subcontractor submissions shall be made through the Contractor. Each drawing shall have a clear space for the stamps of Architect and Contractor. Refer to Division 1. In the case where a CM is hired on the Project, the CM may be designated to receive the Submittals for the Project, log the Submittals, and in some cases reject Submittals that do not conform to Contract requirements. Submittal Procedures for further information.

3.9.5.2 *Copies Required.* Each Submittal shall include one (1) legible, reproducible (if electronic is available, electronic copies shall also be provided) and five (5) legible prints of each drawing or schedule, table, cut sheet, etc., including fabrication, erection, layout and setting drawings, and such other drawings as required under the various sections of the Specifications, until final acceptance thereof is obtained. Subcontractor shall submit copies, in an amount as requested by the Contractor, of: (1) manufacturers' descriptive data for materials, equipment, and fixtures, including catalog sheets showing dimensions, performance, characteristics, and capacities; (2) wiring diagrams and controls; (3) schedules; (4) all seismic calculations and other calculations; and (5) other pertinent information as required by the District or Architect. (See also Division 1)

3.9.5.3 *Corrections.* The Contractor shall make all corrections required by Architect, District or CM and shall resubmit, as required by Architect or CM, corrected copies of Shop Drawings or new samples until approved. Contractor shall direct specific attention in writing or on resubmitted Shop Drawings to revisions other than the corrections required by the Architect on previous submissions. Professional services required for more than one (1) re-review of required Submittals of Shop Drawings, Product Data, or samples are subject to charge to the Contractor pursuant to Article 4.5.

3.9.5.4 *Approval Prior to Commencement of Work.* No portion of the Work requiring a Shop Drawing or sample submission or other Submittal shall be commenced until the submission has been reviewed by Contractor and Architect (and CM, if applicable) and approved by Architect (and CM where applicable) unless specifically directed in writing by the Architect. All such portions of the Work shall be in accordance with approved Shop Drawings and samples.

GENERAL CONDITIONS

3.9.5.5 *District's Property.* All Submittals, Shop Drawings, computer disks, BIM modeling information, clash checks, schedules, annotated Specifications, samples and other Submittals shall become the District's property upon receipt by the District or Architect.

3.9.6 Schedule Requirements for Submittals

Contractor shall obtain and shall submit all required Submittals (i.e. Shop Drawings, Deferred Approvals, Samples, etc.), in accordance with Contractor's "Schedule for Submission of Shop Drawings and Samples" as required in the scheduling portion of the General Conditions at Articles 8 and the Specifications (as long as the Specifications do not conflict with General Conditions. In the case of conflict, the conflicting provision shall be controlled by the General Conditions and the remaining Specifications sections shall be interpreted as if the general conditions language is inserted) with such promptness as to cause no delay in its own Work or in that of any other contractor or subcontractor but in no event later than thirty five (35) days after the Notice to Proceed is issued except in the specific cases noted as an exception under Article ARTICLE 1. No extensions of time will be granted to Contractor or any Subcontractor because of its failure to have Shop Drawings and samples submitted in accordance with Division 1 and the Schedule. Each Subcontractor shall submit all Shop Drawings, samples, and manufacturer's descriptive data for the review of the District, the Contractor, and the Architect through the Contractor.

3.9.6.1 *Consideration of Schedule.* Contractor has considered lead times, DSA or other agency governmental review times, Architect or Engineer review times, manufacturing seasons, and specific long lead procurement concerns for all submittals for the Project.

3.9.7 General Submittal Requirements

3.9.7.1 *Contractor Submittal Representations and Coordination.* By submitting Shop Drawings, Product Data, samples, etc., the Contractor represents that it has determined and verified all materials, field measurements, catalog numbers, related field construction criteria, and other relevant data in connection with each such submission, and that it has checked, verified, and coordinated the information contained within such Submittals with the requirements of the Work and of the Contract Documents, including the construction schedule.

3.9.7.2 *Contractor Coordination.* Contractor shall stamp, sign, and date each Submittal indicating its representation that the Submittal meets all of the requirements of the Contract Documents and evidence Contractor's review through execution of the following stamp to be placed on each Shop Drawings:

“[Contractor] has reviewed and approved the field dimensions and the construction criteria, and has also made written notation regarding any information in the Shop Drawings and Submittals that does not conform to the Contract Documents. This Shop Drawing or Submittal has been coordinated with all other Shop Drawings and Submittals received to date by me as Contractor and this duty of coordination has not been delegated to Subcontractors, material suppliers, the Architect, or the Engineers on this Project.

Signature of Contractor and date

3.9.7.3 *No Deviation from Contract Documents.* The submission of the Shop Drawings, Product Data, samples, etc., shall not deviate from the *requirements* of the Contract Documents

GENERAL CONDITIONS

including detailing and design intent which is specifically outlined in Contract Documents except as specifically authorized by the Architect or through an accepted substitution pursuant to Article ARTICLE 1. All deviations from the Contract Documents shall be narratively described in a transmittal accompanying the Shop Drawings. However, Shop Drawings shall not be used as a means of requesting a substitution, the procedure for which is defined in Article ARTICLE 1, “Substitutions.”

3.9.7.4 *Contractor Responsibility for Shop Drawings Conformance to Contract Documents.* Review by District and Architect shall not relieve the Contractor or any Subcontractor from its responsibility in preparing and submitting proper Shop Drawings in accordance with the Contract Documents.

3.9.7.5 *Incomplete Submittals.* Any submission, which in Architect’s opinion is incomplete, contains errors, or has been checked superficially, will be returned not reviewed by the Architect for resubmission by the Contractor. Refer to Submittal Procedures of the Specifications for additional information. The Contractor shall be responsible for any related delays and shall not be the basis for any Claim.

3.9.7.6 *Shop Drawings and Submittals Shall Not Be Used as a Method to Make a Substitution.* Shop Drawings and Submittals shall not be used as a means of requesting a substitution or to make changes in the Contract Documents. If changes are made to the Contract Documents through the Shop Drawings, the Architect shall have the right to reject the Submittal. If the Architect does not note the deviation from the approved Plans and Specifications, the Contractor is still responsible for the change and the Architect or the District may require the Shop Drawings be revised to properly reflect the approved Contract Documents. The Architect or District may also require that the Contractor bear all costs under Article 4.5 and consequential damages associated with a CCD to revise Plans and Specifications to accommodate the deviation from approved Plans and Specifications.

3.9.7.7 Extent of Review. In reviewing Shop Drawings, the Architect will not verify dimensions and field conditions. The Architect will review and approve Shop Drawings, Product Data, samples, etc., for aesthetics and for conformance with the design concept of the Work and the information in the Contract Documents. The Architect’s review shall neither be construed as a complete check which relieves the Contractor, Subcontractor, manufacturer, fabricator, or supplier from responsibility for any deficiency that may exist or from any departures or deviations from the requirements of the Contract Documents unless the Contractor has, in writing, called the Architect’s attention to the deviations at the time of submission. The Architect’s review shall not relieve the Contractor or Subcontractors from responsibility for errors of any sort in Shop Drawings or schedules, for proper fitting of the Work, coordination of the differing Subcontractor trades and Shop Drawings and Work which is not indicated on the Shop Drawings at the time of submission of Shop Drawings. Contractor and Subcontractors shall be solely responsible for any quantities which may be shown on the Submittals or Contract Documents.

3.10 **SUBSTITUTIONS**

3.10.1 Definition

A Substitution is a change in product, material, equipment, or method of construction from those required by the Construction Documents proposed by the Contractor. For this Project, a Substitution is subject to the filing of a Construction Substitution Request Form at the time of bid and meeting the requirements of this Article.

3.10.2 One Product Specified

GENERAL CONDITIONS

Unless the Specifications state that no substitution is permitted, whenever the Contract Documents indicate any specific article, device, equipment, product, material, fixture, patented process, form, method, or type of construction or any specific name, make, trade name, or catalog number, with or without the words “or equal,” such specification shall be deemed to be used for the purpose of facilitating description of the material, process, or article desired and shall be deemed to be followed by the words “or equal.” Subject to the requirements of properly submitting a Substitution Request for as Addressed in Article ARTICLE 1, the Contractor may, unless otherwise stated, offer any material, process, article, etc., which shall be materially equal or better in every respect to that so indicated or specified (“Specified Item”) and will completely accomplish the purpose of the Contract Documents.

3.10.3 Products Specified Which Are Commercially Unavailable

If the Contractor fails to make a request for substitutions for products, prior to the submission of its bid, and such products subsequently become commercially unavailable, the Contractor may request a substitution for such commercially unavailable item. The decision to grant this request is solely at the District’s discretion. The written approval of the District, consistent with the procedure for Change Orders, shall be required for the use of a proposed substitute material. The District may condition its approval of the substitution upon the delivery to District of an extended warranty or other assurances of adequate performance of the substitution as well as an equitable deduction in the Contract Price should the substituted item cost less than the Specified Item. All risks of delay due the approval of a requested substitution by the DSA, or any other governmental agency having jurisdiction, shall be on the requesting party. All additional costs, DSA review costs, all procurement and construction delays, and all costs for review by the Architect or its consultants shall be the responsibility of the Contractor and will be deducted from Contractor’s pay request.

3.10.4 Substitution Request Form

Requests for substitutions of products, materials, or processes in place of a Specified Item must be in writing on the District’s Substitution Request Form (“Request Form”) at the time of submitting bids to the District, except as provided for in Article ARTICLE 1.

The Request Form must be accompanied by evidence as to whether the proposed substitution:

- a. Is equal in quality/service/ability to the Specified Item;
- b. Will entail no changes in detail, construction, and scheduling of related work;
- c. Will be acceptable in consideration of the required design and artistic effect;
- d. Will provide no cost disadvantage to the District;
- e. Will require no excessive or more expensive maintenance, including adequacy and availability of replacement parts; and
- f. Will required no change of the construction schedule.

In completing the Request Form, the bidder must state, with respect to each requested substitution, whether the bidder will agree to provide the Specified Item in the event that the District denies the bidder’s request for such requested substitution. In the event that the bidder has agreed in the Request

GENERAL CONDITIONS

Form to provide the Specified Item and the District denies the bidder's requested substitution for a Specified Item, the bidder shall provide the Specified Item without any additional cost or charge to the District.

After bids are opened, the apparent lowest bidder shall provide, within five (5) days of opening such bids, any and all Drawing, Specifications, samples, performance data, calculations, and other information, as may be required to assist the Architect, CM and the District in determining whether the proposed substitution is acceptable. The burden of establishing these facts shall be upon the bidder.

After the District's receipt of such evidence by the bidder, the District will make its final decision as to whether the bidder's request for substitution for any Specified Items will be granted. The decision as to whether a proposed request for substitution is equal to a Specified Item shall be at the sole discretion of the District. Any request for substitution that is granted by the District shall be documented and processed through a Change Order. Contractor must submit a complete Submittal of the requested substitution and a Shop Drawing showing configuration, dimensions, and other critical information associated with the substitution that meets the requirements of Article ARTICLE 1. The District may condition its approval of any substitution upon delivery to the District of an extended warranty or other assurances of adequate performance of the substitution. Any and all risks of delay due to approval by the DSA or any other governmental agency having jurisdiction shall be on the bidder.

If the Architect and District accept a proposed substitution, the Contractor agrees to pay for all DSA review costs, engineering and design services, including, without limitation, compensation to the Architect and affected engineers for their required time to process such substitution through the Division of the State Architect, if required, and to make all changes and adjustments in materials or the work of all trades directly or indirectly affected by the substituted item or items at no cost to the District.

3.10.5 Substitution Requests After Bid

The District, in its sole discretion, may accept a request for substitution by the Contractor or may request Contractor substitute a specified item. Any substitutions requested after bids are opened shall be subject to the same conditions and requirements set forth in Article ARTICLE 1 above. If any substitutions, that in the District or Architect's determination, results in a credit to the District, the credit amount shall be agreed upon in writing, otherwise, the request for substitution shall be deemed denied.

3.11 **INTEGRATION OF WORK**

3.11.1 Scope

The Contractor shall be responsible for cutting, fitting, or patching to complete the Work and to make all parts fit together properly. Contractor shall be responsible for ensuring that all trades are coordinated and scheduled so as to ensure the timely and proper execution of the work. When modifying existing work or installing new Work adjacent to existing work, Contractor shall match, as closely as conditions of Site and materials will allow, the finishes, textures, and colors of the original work, refinishing existing work at no additional cost to District. All cost caused by defective or ill-timed work shall be borne by Contractor. Contractor shall be solely responsible for protecting existing work on adjacent properties and shall obtain all required permits for shoring and excavations near property lines.

3.11.2 Structural Members

New or existing structural members and elements, including reinforcing bars and seismic bracing, shall not be cut, bored, or drilled except by written authority of the Architect. Work done contrary

GENERAL CONDITIONS

to such authority is at the Contractor's risk and subject to replacement at its own expense without reimbursement under the Contract. Schedule delays resulting from Agency approvals for unauthorized work shall be the Contractor's responsibility.

3.11.3 Subsequent Removal

Permission to patch any areas or items of the Work shall not constitute a waiver of the District's or the Architect's right to require complete removal and replacement of the areas of items of the Work if, in the opinion of the Architect or the District, the patching does not satisfactorily restore quality and appearance of the Work or does not otherwise conform to the Contract Documents.

3.12 CLEANING UP

3.12.1 Contractor's Responsibility to Clean Up

Contractor at all times shall keep premises free from debris such as waste, dust, excess water, storm water runoffs, rubbish, and excess materials and equipment. Contractor shall not leave debris under, in, or about the premises, but shall promptly remove same from the premises and dispose of it in a lawful manner. Disposal receipts or dump tickets shall be furnished to the Architect within five (5) days of request.

Contractor shall remove rubbish and debris resulting from the Work on a daily basis. Contractor shall maintain the structures and Site in a clean and orderly condition at all times until acceptance of the Project by the District. Contractor shall keep its access driveways and adjacent streets, sidewalks, gutters and drains free of rubbish, debris and excess water by cleaning and removal each day. All concrete, sidewalks, and paths of travel shall be broom cleaned daily.

3.12.2 General Final Clean-Up

Upon completion of Work, Contractor shall employ experience workers or professional cleaners for final cleaning. Contractor shall clean each surface to the condition expected in a normal, commercial, building cleaning and maintenance program including, but not limited to, the performed of the following:

- a. Clean interior and exterior of buildings, including fixtures, equipment, walls, floors, ceilings, roofs, window sills and ledges, horizontal projections, and any areas where debris has collected, so surfaces are free from foreign material or discoloration;
- b. Clean the Project site. The grounds should be cleared of any Contractor equipment, raked clean of debris and trash removed. Sweep paved areas broom clean;
- c. Repair or replace any damaged materials. Replace any chipped or broken glass;
- d. Remove any and all stains;
- e. Remove labels that aren't permanent labels;

GENERAL CONDITIONS

- f. Clean and polish all glass, plumbing fixtures, equipment, finish hardware and similar finish surfaces. Remove any glazing compounds;
- g. Remove temporary utilities, fencing, barricades, planking, sanitary facilities and similar temporary facilities from Site;
- h. Remove temporary film that remains on any hardware, doors or other surfaces; and
- i. Seal the bottom and tops of all doors.

3.12.3 **Special Clean-Up.**

In addition to the general cleaning, the following special cleaning shall be done at the completion of the Work in accordance with the Specifications including, but not limited to:

- a. Remove putty stains from glazing, then wash and polish glazing;
- b. Remove marks, stains, fingerprints and other soil or dirt from painted, stained or decorated work;
- c. Remove temporary protection and clean and polish floors and waxed surfaces;
- d. Clean and polish hardware and plumbing trim; remove stains, dust, dirt, plaster and paint;
- e. Wipe surfaces of mechanical and electrical equipment;
- f. Remove spots, soil, plaster and paint from tile work, and wash tile;
- g. Clean all fixtures and equipment, remove excess lubrication, clean light fixtures and lamps, polish metal surfaces;
- h. Vacuum-clean carpeted surfaces; and
- i. Remove debris from roofs, down spout and drainage system.

3.12.4 **Failure to Cleanup**

If the Contractor fails to clean up as provided in the Contract Documents, the District may do so, and the cost thereof shall be the responsibility of the Contractor pursuant to Article 2.2 and seek a Deductive Change Order.

3.13 **ACCESS TO WORK**

The Contractor shall provide the District, the Architect, Engineers and the Inspector of Record, access to the Work in preparation and progress wherever located. Contractor shall provide safe and proper facilities for such access so that District's representatives may perform their functions.

CONTRACTOR IS AWARE THAT THIS CONTRACT MAY BE SPLIT INTO SEVERAL PHASES AS ADDRESSED IN ARTICLE 6.

GENERAL CONDITIONS

3.13.1 Special Inspection, Inspections or Tests Out of State, Out of Country or Remote from Project

If Contractor has a Subcontractor or supplier that requires in plant or special inspections or inspections or tests that are out of the country, out of the state, or a distance of more than 200 miles from the Project site, the Special Inspector or Inspector shall be provided access so the special inspection or inspection may occur in the remote location. In some cases, the DSA Inspector may also require access in addition to Special Inspectors and individuals performing tests. Inspections/tests shall occur during normal work hours. (See also Article 4.3.6)

3.14 **ROYALTIES AND PATENTS**

3.14.1 Payment and Indemnity for Infringement

Contractor shall hold and save the District and its officers, agents, and employees, the Construction Manager, the Architect, and the Architect's consultants harmless from liability of any nature or kind, including cost and expense, for or on account of any patented or unpatented invention, process, article, or appliance manufactured or used in the performance of the Contract, including its use by the District, unless otherwise specifically provided in the Contract Documents, and unless such liability arises from the sole negligence, or active negligence, or willful misconduct of the District, the Architect, or the Architect's consultants.

3.14.2 Review

The review by the Architect of any method of construction, invention, appliance, process, article, device, or material of any kind shall be for its adequacy for the Work and shall not be an approval for the use by the Contractor in violation of any patent or other rights of any person or entity.

3.15 **INDEMNIFICATION**

3.15.1 Contractor

See Agreement Form. Contractor shall ensure that its contract with each of its Subcontractors contains provisions requiring the Subcontractors to defend, indemnify and hold harmless the District, Architect, Inspector, the State of California to a minimum level as set forth in this Article and consistent with the indemnity and hold harmless language in the Agreement Form.

The Contractor's and Subcontractors' obligation to defend, indemnify and hold harmless the District, Architect, Inspector, the State of California and their officers, employees, agents and independent contractors hereunder shall include, without limitation, any and all claims, damages, and costs for the following: (1) any damages or injury to or death of any person, and damage or injury to, loss (including theft), or loss of use of, any property; (2) breach of any warranty, express or implied; (3) failure of the Contractor or Subcontractors to comply with any applicable governmental law, rule, regulation, or other requirement; (4) products installed in or used in connection with the Work; and (5) any claims of violation of the Americans with Disabilities Act ("ADA")

3.16 **SUBMISSION OF DAILY REPORTS**

3.16.1 General

GENERAL CONDITIONS

By 10:00 a.m. on the following business day, the Contractor shall submit a Daily Report to the Inspector and copy the Architect for the previous day's Work. If there is a Construction Manager, the original Daily Report is to be provided to the Construction Manager and copies sent to the Architect and the Inspector. Daily Reports shall be prepared on forms approved by the District, together with applicable delivery tickets, listing all labor, materials, and equipment involved for that day. The District reserves the right to note inconsistencies or inaccuracies in the Daily Reports. In such cases, pertinent notes shall be entered by each party to explain points which cannot be resolved that day. Each party shall retain a signed copy of the report. Daily Reports by Subcontractors or others shall be submitted through the Contractor.

3.16.2 Labor

The Daily Report shall show names of workers, classifications, hours worked and hourly rate. The locations where work occurred shall also be identified in the Daily Report. Project superintendent expenses are not allowed.

3.16.3 Materials

The Daily Report required shall describe and list quantities of materials used and unit costs.

3.16.4 Equipment

The Daily Report required shall show type of equipment, size, identification number, and hours of operation, including loading and transportation, if applicable, and hourly/daily cost. Move-on and move-off fees shall be noted.

3.16.5 Other Services and Expenditures

Other services and expenditures shall be described in the Daily Report in detail as the District requires.

3.16.6 Failure to Submit Daily Report

If Contractor does not submit its Daily Report by 10 am the next business day, the Inspector of Record shall prepare a Daily Report addressing each of the above items. The cost for the Inspector's services to prepare the Daily Report shall be addressed through a Deductive Change Order under Article 7.7.4.

3.17 **AS-BUILT DRAWINGS AND ANNOTATED SPECIFICATIONS**

Throughout the duration of the Project, Contractor shall maintain on a current basis an accurate and complete set of As-Built Drawings (and Annotated Specifications) clearly showing all changes, revisions to Specifications and substitutions during construction, including, without limitation, field changes and the final location of all electrical and mechanical equipment, utility lines, ducts, outlets, structural members, walls, partitions, and other significant features. In case a Specification allows Contractor to elect one of several brands, makes, or types of material or equipment, the annotations shall show which of the allowable items the Contractor has furnished. The Contractor will update the As-Built Drawings and Annotated Specifications as often as necessary to keep them current, but no less often than weekly.

GENERAL CONDITIONS

Contractor shall update As-Built Drawings with complete information on an area of Work at or near the time when the Work is being performed and prior to any DSA 152 sign off and prior to any Work being covered.

The As-Built Drawings and Annotated Specifications shall be kept at the Site and available for review and inspection by the District and the Architect. Failure to maintain and update the As-Built Drawings is a basis to withhold Progress Payments pursuant to Article 9.6.

3.17.1 Upon Beneficial Occupancy

Contractor shall obtain and pay for reproducible Plans upon Beneficial Occupancy. Contractor shall deliver Plans to District Representative (Construction Manager if one is hired for the Project).

3.17.2 As-Builts at Completion of Work

Upon completion of the Work and prior to and as a condition precedent to Application for Retention Payment, the Contractor will provide one neatly prepared and complete set of As-Built Drawings and Annotated Specifications to the District. Contractor shall certify the As-Builts as a complete and accurate reflection of the actual construction conditions of the Work by affixing a stamp indicating the Drawings are As-Builts and certifying accuracy on the final set of As-Builts. Failure to deliver a complete As-Built set of Drawings may result in significant withholdings to ensure Work is properly documented. (See Article 9.9.2)

3.17.3 Log of Control and Survey Documentation

Contractor shall complete and maintain an accurate log or all control and survey documentation for the Project as the Work progresses. All reference and control points shall be recorded on the As-Built Drawings. The basis of elevations shall be one of the established benchmarks that must be maintained on the As-Builts.

3.17.4 Record Coordinates for Key Items

Contractor shall record, by coordinates, all utilities on-site with top of pipe elevations, major grade and alignment changes, rim, grate or top of curb and flow line elevations of all drainage structures and sewer manholes. Contractor shall update record information at or near the time when work is occurring in an area and prior to DSA 152 sign off on any category of Work and prior to covering the Work.

3.17.5 BIM As-Built Drawings

If BIM is utilized for the Project, then an electronic version of such As-Built Drawings and Annotated Specifications will be delivered to District (in an acceptable format to District).

3.18 **EQUIPMENT MANUALS**

Contractor shall obtain and furnish three (3) complete sets of manuals containing the manufacturers' instructions for maintenance and operation of each item of equipment and apparatus furnished under the Contract Documents and any additional data specifically requested under the various sections of the Specifications for each division of the Work. The manuals shall be arranged in logical,

GENERAL CONDITIONS

sequential order, labeled, indexed, and placed in three-ring binders. At the completion of its Work, the Contractor shall certify, by endorsement thereon, that each of the manuals is complete, accurate, and covers all of its Work. Prior to submittal of Contractor's Application for Retention Payment, and as a further condition to its approval by the Architect, each Subcontractor shall deliver the manuals, arranged in logical, sequential order, labeled, indexed, endorsed, and placed in three-ring binders, to the Contractor, who shall assemble these manuals for all divisions of the Work, review them for completeness, and submit them to the District through the Architect.

3.19 DIR REGISTRATION

Strict compliance with all DIR registration requirements in accordance with Labor Code sections 1725.5 and 1771.1 is a material obligation of the Contractor and all of its subcontractors (of any tier) under the Contract Documents. The foregoing includes, without limitation, compliance with DIR registration requirements at all times during performance of the Work by the Contractor and all of its subcontractors of any tier. The failure of the Contractor and all subcontractors of any tier to be properly registered with DIR at all times during performance of the Work is a material breach of the Contract and subject to termination for cause.

An affirmative and ongoing obligation of the Contractor under the Contract Documents is the verification that all subcontractors of any tier are at all times during performance of the Work are in full and strict compliance with the DIR registration requirements. The Contractor shall not permit or allow any subcontractor of any tier to perform any Work without the Contractor's verification that all subcontractors are in full and strict compliance with the DIR registration requirements. Any subcontractors of any tier not properly registered with DIR shall be substituted in accordance with Labor Code section 1771.1. Contractor or its subcontractors of any tier shall not be entitled to any additional costs or time arising from or in any way related to compliance with the DIR registration requirements.

GENERAL CONDITIONS

ARTICLE 4 ADMINISTRATION OF THE CONTRACT AND CLAIMS

4.1 ARCHITECT

4.1.1 Replacement of Architect

In the case of the termination of the Architect, the District may appoint an Architect or another construction professional or may perform such functions with its own licensed professional personnel. The status of the replacement Architect under the Contract Documents shall be the same as that of the former Architect.

4.2 ARCHITECT'S ADMINISTRATION OF THE CONTRACT

4.2.1 Status

Pursuant to Titles 2 of the California Code of Regulations and as required pursuant to the Field Act, Education Code 17280 et seq., the Architect will provide administration of the Contract Documents and the Work, and will be the District's representative during construction, as well as during the one (1) year period following the commencement of any warranties. The Architect will have authority to act on behalf of the District only to the extent provided in the Contract Documents.

4.2.2 Site Visits

The Architect will visit the Site at intervals necessary in the judgment of the Architect to become generally familiar with the progress and quality of the Work and to determine in general if the Work is being performed in accordance with the Contract Documents and as otherwise required by DSA.

4.2.3 Limitations of Construction Responsibility

The Architect, District and CM shall not have control over, charge of, or be responsible for construction means, methods, techniques, schedules, sequences or procedures, fabrication, procurement, shipment, delivery, receipt, installation, or for safety precautions and programs in connection with the Work, since these are solely the Contractor's responsibility under the Contract Documents. The Architect, District and CM shall not be responsible for the Contractor's, Subcontractors', material or equipment suppliers', or any other person's schedules or failure to carry out the Work in accordance with the Contract Documents. The Architect, District and CM shall not have control over or charge of acts or omissions of the Contractor, Subcontractors, their agents or employees, or any other persons or entities performing or supplying portions of the Work. The Contractor shall not be relieved of obligations to perform the Work in accordance with the Contract Documents either by activities or duties of the Architect, District or CM in the Architect, District or CM's administration of the Contract Documents, or by tests, inspections, or approvals required or performed by persons other than the Contractor.

4.2.4 Communications Facilitating Contract Administration

GENERAL CONDITIONS

Except when direct communications are warranted by special circumstances, the District and the Contractor shall communicate through the Architect, primarily through Architect provided Construction Administration Software which allows viewing and collaboration between District, Architect and Inspector. Where direct communication is necessary between the District and the Contractor, the District's communication shall be through the District's authorized designated person. The Architect and CM shall be promptly informed, and shall receive copies of all written communications. Contractor shall not rely upon any communications from the District that is not from the District's Representative. Communications by and with the Architect's consultants shall be through the Architect. Communications by and with Subcontractors and material or equipment suppliers shall be through the Contractor. Copies of all communication should be sent to the Architect, District Representative and Inspector.

4.2.5 Payment Applications

The Architect will review and make recommendations to the District regarding the amounts due the Contractor on the Certificates for Payment pursuant to Article 9.3.4 and subject to the Inspector's review, (CM review, if applicable) and Architect's observation. This review of Payment Applications is sometimes called a "Pencil Draft." Return of a Pencil Draft shall constitute the District's dispute of the Payment Application that has been submitted. Contractor shall promptly respond to Pencil Drafts or Contractor's Payment Applications may be delayed. Contractor's failure to promptly respond to a Pencil Draft shall qualify as a delay in the Prompt Payment of a Request for Payment or Request for Retention.

4.2.6 Rejection of Work

In addition to the rights, duties, and obligations of the Inspector under this Article, the Architect may recommend to the District that the District reject Work which does not conform to the Contract Documents. Whenever the Architect considers it necessary or advisable to achieve the intent of the Contract Documents, the Architect (and/or CM) may recommend to the District that the District require additional inspection or testing of the Work in accordance with Article 13.5, whether or not such Work is Fabricated, installed, or completed. District may have Non-conforming Work removed and replaced pursuant to Article 9.7. However, neither this authority of the Architect (or CM) nor a decision made in good faith either to exercise or not to exercise such authority shall give rise to a duty or responsibility of the Architect (or CM) to the Contractor, Subcontractors, material and equipment suppliers, their agents or employees, or other persons performing portions of the Work.

Contractor shall, without charge, replace or correct Work found by the District to not be in conformance to Contract requirements. Contractor shall promptly segregate and remove rejected materials from the Project site.

This section does not address a Notice of Non-Compliance and the remedies associated with a Notice of Non-Compliance which are addressed at Article 7.1.2

4.2.7 Warranties upon Completion

The Architect (and where applicable CM), in conjunction with the Inspector will conduct field reviews of the Work to determine the date of Substantial Completion and of Final Completion, shall receive and forward to the District for the District's review written warranties and related documents required by the Contract and assembled by the Contractor, and will issue a final Certificate for Payment when the Architect believes the Work has been completed in compliance with the requirements of the Contract Documents (See Article 9.11 for Close-Out). The handling by the Architect (or where applicable CM) of such warranties, maintenance manuals, or similar documents shall not diminish or transfer to the

GENERAL CONDITIONS

Architect any responsibilities or liabilities required by the Contract Documents of the Contractor or other entities, parties, or persons performing or supplying the Work.

On some Projects, the District will take a phased occupancy of the Project. In those cases, the District may commence the running of warranties on the buildings, or phases that are accepted after Punch List is completed and the District has accepted Completion of the separate phase. A separate Notice of Completion may be filed for the separate building or phase of work and warranties shall commence for the separate phase only to the extent that warranties do not require coordination or connection to other buildings or other parts of the site and only if the warranted item is completed to its entirety in the segregated building or phased area.

If written warranties are not provided at the time the Punch List is nearing completion, Architect (with recommendations from the CM and Inspector) shall determine the dollar value of the warranties and shall make recommendation for withholdings necessary to effectuate the transfer of such warranties to the District for future use as part of the Punch List for the Project pursuant to Article 9.6.

Warranties are not commenced through utilizing of equipment for testing and operation as necessary to acclimate buildings or where necessary to test systems.

4.2.8 Interpretation

The Architect will interpret and decide matters concerning performance and requirements of the Contract Documents. Architect shall make clarifications as necessary to interpret the Contract Documents.

4.3 **PROJECT INSPECTOR**

4.3.1 General

One or more Project Inspectors employed by the District and approved by the Division of the State Architect will be assigned to the Work in accordance with the requirements of Title 24 of the California Code of Regulations. The Inspector(s) duties are as specifically defined in Title 24 Section 4-333 and 4-342 and in DSA IR A-8.

4.3.2 Inspector's Duties and DSA Noted Timelines for Inspection

All Work shall be under the observation of the Inspector. Contractor shall establish a protocol for requesting inspection with Inspector so as to not delay the Work and provide adequate time for the Inspector to perform inspection. If such a protocol is not established ahead of time, Inspector may utilize the time criteria set by Title 24 of 48 hours in advance of submitting form DSA 156 for each new area. The Inspector shall have free access to any or all parts of the Work at any time. The Contractor shall furnish the Inspector such information as may be necessary to keep the Inspector fully informed regarding progress and manner of Work and character of materials. Such observations shall not, in any way, relieve the Contractor from responsibility for full compliance with all terms and conditions of the Contract, or be construed to lessen to any degree the Contractor's responsibility for providing efficient and capable superintendence. The Inspector is not authorized to make changes in the Drawings or Specifications nor shall the Inspector's approval of the Work and methods relieve the Contractor of responsibility for the correction of subsequently discovered defects, or from its obligation to comply with the Contract Documents.

GENERAL CONDITIONS

Inspector shall electronically post DSA required documents on the DSA electronic posting website. It is the Contractor's responsibility to determine the status of posting and determine if all the criteria for sign off of a category of Work on the Project Inspection Card (Form DSA 152) as defined more thoroughly in the most current version of the DSA 152 manual posted on the DSA website.

Inspector may collaborate with Contractor about approval of areas that may be constructed and approved incrementally under the DSA 152 card pursuant to the guidelines of PR-13 at Article 1.17. Inspector shall work with Contractor to present incremental approval proposals to DSA.

4.3.3 Inspector's Authority to Reject or Stop Work

The Inspector shall have the authority to reject Work whenever provisions of the Contract Documents are not being complied with, and Contractor shall instruct its Subcontractors and employees accordingly. In addition, the Inspector may stop any Work that poses a probable risk of harm to persons or property. The Contractor shall instruct its employees, Subcontractors, material and equipment suppliers, etc., accordingly. The absence of any Stop Work Order or rejection of any portion of the Work shall not relieve the Contractor from any of its obligations pursuant to the Contract Documents.

4.3.4 Inspector's Facilities

Within seven (7) days after the notice to proceed, the Contractor shall provide the Inspector with the temporary facilities as required. More specific requirements for the Inspector facilities may be further described under Division 1 of the Specifications.

4.3.5 Testing Times

The District will provide inspection and testing at its cost during the normal eight (8) hour day Monday through Friday (except holidays). Work by the Contractor outside of the normal eight (8) hour day shall constitute an authorization from the Contractor to the District to provide inspection and testing as required outside of the normal eight (8) hour day. Contractor shall provide adequate time for inspections so as to not delay the Work. An advanced timing protocol may be established pursuant to Article 4.3.2. If the Contractor is behind Schedule then it is incumbent on the Contractor to provide advance forecast through look ahead of the anticipated date for inspection so the Inspector may plan their activities so as to not delay the Project. Contractor shall reimburse District for any additional costs associated with inspection and testing (including re-inspection and re-testing) outside the normal eight-hour day and for any retests caused by the Contractor.

It is the Contractor's responsibility to request special inspections with sufficient time so all testing may be timely completed and posted so work may proceed and the Inspector's signature is attached to the Project Inspection Card (Form 152). Specifically, timely request for special inspection under the DSA Verified Report Forms 291 (laboratory), DSA Verified Report Form 292 (Special Inspection), and DSA Verified Report 293 (geotechnical) since DSA requirements under PR 13-01 specifically gives the Special Inspections 14 days to post to the DSA website. Failure to plan and pay (if applicable) for quicker delivery of Special Inspections may be counted as Float, but is not considered Governmental Delay Float under Article 8.1.4.

4.3.6 Special Inspections, Inspections or Tests Out of State, Out of Country or Remote from Project

If Contractor has a Subcontractor or supplier that requires in plant or special inspections, inspections or tests that are out of the country, out of the state or a distance of more than 200 miles from

GENERAL CONDITIONS

the Project Site, the District shall provide the Special Inspector or individual performing tests time for inspection and testing during normal work hours. Contractor, however, is responsible for the cost of travel, housing, food, out of area premiums that may be in the Inspector/Testing Agreement with District, or other expenses necessary to ensure proper inspection, special inspection or testing is provided by a DSA Certified Inspector, Special Inspector, or individual performing tests. In some cases all three (DSA Inspector, Special Inspector, and Tester) may be required. In addition, if the DSA Certified Inspector, Special Inspector, or individual performing test has contractual travel clauses or special rates for out of town inspection, Contractor is responsible for all costs associated with the contractual travel costs in addition to all other costs. Arrangements for inspection and/or testing shall be made far enough in advance so as to not delay the Work.

4.4 STOP WORK ORDER

DSA may issue a Stop Work Order, or an Order to Comply, when either (1) the Work proceeds without DSA approval; (2) the Work proceeds without a DSA Inspector of Record, or (3) where DSA determines that the Work is not being performed in accordance with applicable rules and regulations, and would compromise the structural integrity of the Project or would endanger lives. If a Stop Work Order is issued, the Work in the affected area shall cease until DSA withdraws the Stop Work Order. Pursuant to Education Code section 17307.5(b), the District shall not be held liable in any action filed against the District for any delays caused by compliance with the Stop Work Order, except to the extent that an error or omission by the District is the basis for the issuance of the Stop Work Order.

Examples of Stop Work Orders that may be issued by DSA include DSA Bulletin 07-04 and Policy 10-01, the installation of automatic fire sprinkler systems without approved Plans, covering Work that has not been approved by Inspector on DSA Project Inspection Card (Form 152).

4.5 RESPONSIBILITY FOR ADDITIONAL CHARGES INCURRED BY THE DISTRICT FOR PROFESSIONAL SERVICES

If at any time prior to the completion of the requirements under the Contract Documents, the District is required to provide or secure additional professional services (including CM, Inspection, Architect, Engineering and Special Consultant Services) for any reason by any act of the Contractor, the District may seek a Deductive Change Order for any costs incurred for any such additional services, which costs shall be deducted from the next progress payment. A Deductive Change Order shall be independent from any other District remedies and shall not be considered a waiver of any District rights or remedies. If payments then or thereafter due to the Contractor are not sufficient to cover such amounts, the Contractor shall pay the difference to the District. Additional services shall include, but shall not be limited to, the following:

- a. Services made necessary by the default of the Contractor (Article 14 or Article 2.2).
- b. Services made necessary due to the defects or deficiencies in the Work of the Contractor (Article 2.2 and Article 9.6).
- c. Spurious or frivolous RFI's issued that do not conform to the requirements of Article 7.4. Issuance of the same RFI after receiving an answer from the Architect or Engineer
- d. Review of Schedules that are provided by Contractor that do not Conform with the Requirements of Article 8.

GENERAL CONDITIONS

- e. Preparation of a CCD or WD to correct a Contractor Deficiency, or Contractor Caused Notice of Non-Compliance (See Article 7.3).
- f. Review of Incomplete Shop Drawings or Submittals, including the submission of Piecemeal Shop Drawings or Submittals unless piecemeal Submittals are specifically agreed upon by District (See Article ARTICLE 1)
- g. Services required by failure of the Contractor to perform according to any provision of the Contract Documents.
- h. Services in connection with evaluating substitutions of products, materials, equipment, Subcontractors' proposed by the Contractor, and making subsequent revisions to Drawings, Specifications, obtaining DSA approvals, DSA costs for review of CCD's, other governmental agency review costs, and providing other documentation required (except for the situation where the specified item is no longer manufactured or available). (See Article ARTICLE 1)
- i. Services for evaluating and processing Claims or Disputes submitted by the Contractor in connection with the Work outside the established Change Order process.
- j. Services required by the failure of the Contractor to prosecute the Work in a timely manner in compliance within the specified time of completion.
- k. Services in conjunction with the testing, adjusting, balancing and start-up of equipment other than the normal amount customarily associated for the type of Work involved.
- l. Services in conjunction with more than one (1) re-review of Submittals of Shop Drawings, Product Data, samples, RFI's etc.

4.6 DISPUTES AND CLAIMS

4.6.1 Decision of Architect

“Disputes” or “Claims” as defined in Article 4.6.9.1 between District and Contractor involving money or time, including those alleging an error or omission by the Architect shall be referred initially to the Architect for action as provided in Article 4.6.2 within ten (10) days after Contractor's Article 7 request for Change is denied. If there is a CM, the CM shall receive the Dispute and may review and also assemble opinions and documents to assist the Architect. A decision by the Architect, as provided in Article 4.6.5, shall be required as a condition precedent to proceeding with remedies set forth in Article 4.6.9 as to all such matters arising prior to the date Retention Payment Application is due, regardless of whether such matters relate to execution and progress of the Work, or the extent to which the Work has reached Final Completion.

The condition precedent of an Architect decision shall be waived if: (1) the position of Architect is vacant; (2) the Architect has failed to take action required under Article 4.6.5 within the time periods required therein; or (3) the Dispute or Claim relates to a stop notice claim not arising from any extra Change Order or Immediate Change Directive for which approval has not been provided.

4.6.2 Architect's Review

GENERAL CONDITIONS

The Architect (and CM) will review the Dispute and take one or more of the following preliminary actions upon receipt of a Dispute: (1) request additional supporting data from the claimant; (2) submit a schedule to the parties indicating when the Architect expects to take action; (3) reject the Dispute in whole or in part, stating reasons for rejection; (4) recommend approval of the Dispute; or (5) suggest a compromise. The Architect may also, but is not obligated to, notify the Surety, if any, of the nature and amount of the Dispute.

4.6.2.1 *Architectural Immunity.* Architect review of Disputes and Claims shall be impartial and meant to resolve Disputes and Claims. Pursuant to the case, Huber, Hunt & Nichols, Inc. v. Moore (1977) 67 Cal.App.3d 278, the Architect is provided a quasi-judicial immunity for interpreting and deciding Disputes and Claims between the District and Contractor.

4.6.3 Documentation if Resolved

If a Dispute has been resolved, the Architect (and/or CM) will prepare a Change Order or obtain appropriate documentation to document the terms for Board approval.

4.6.4 Actions if Not Resolved

If a Dispute has not been resolved and all documentation requested pursuant to Article 4.6.2 has been provided, the Contractor shall, within ten (10) days after the Architect's initial response, assemble all the documents involved in the Dispute including copies of all back-up documentation of costs and the basis for the Dispute and take one or more of the following actions: (1) modify the initial Dispute; (2) notify the Architect that the initial Dispute stands; or (3) supplement with additional supporting data and re-submit to the Architect under Article 4.6.2.

4.6.5 Architect's Written Decision

If a Dispute has not been resolved after consideration of the foregoing and of other evidence presented by the parties or requested by the Architect, the Architect (or Architect through CM) shall provide a written decision twenty (20) days after compliance with Article 4.6.4. Upon expiration of such time period, the Architect (or Architect through CM) will render to the parties its written decision relative to the Dispute, including any change in the Contract Sum or Contract Time or both. The Architect may also request reasonable additional time to complete Architect's written decision.

If the resolution of the Dispute by the Architect is not satisfactory to the Contractor and copies of all back-up documentation of costs and the basis for the Dispute is fully articulated in a package of material that is complete, the Contractor may then submit a Claim to the District under Article 4.6.9.

4.6.6 Continuing Contract Performance

Pending final resolution of a Dispute or Claim, including, negotiation, mediation, arbitration, or litigation, the Contractor shall proceed diligently with performance of the Contract, and the District shall continue to make any undisputed payments in accordance with the Contract (less any withholdings or offsets). If the Claim is not resolved, Contractor agrees it will neither rescind the Contract nor stop the progress of the work, but Contractor's sole remedy shall be to submit such controversy to determination by a court of competent jurisdiction in the county where the Project is located, after the Project has been completed, and not before.

GENERAL CONDITIONS

4.6.6.1 *District's Option to Submit Individual Disputes to Arbitration during Claims and Disputes Process.* At the District's sole option, in order to more efficiently resolve Claims during the Project and prior to the completion of the Claims Process, pursuant to Government Code section 9201, the District may submit individual Disputes or Claims for binding arbitration and Contractor agrees to the resolution of for each individual Dispute or Claim by an Arbitrator, including resolution of time and delays. If binding arbitration is utilized for individual Disputes or Claims, such resolution is full and final as to that particular Dispute or Claim. THIS INDIVIDUAL DISPUTE ARBITRATION PROCESS IS NOT AN ARBITRATION CLAUSE AND SHALL NOT BE CONSTRUED AS AN AGREEMENT TO ARBITRATE. THIS INDIVIDUAL DISPUTES ARBITRATION PROCESS IS FOR THE SOLE PURPOSE OF STREAMLINING AND RESOLVING DISPUTES OR CLAIMS DURING CONSTRUCTION AND SHALL BE REQUESTED ON SPECIFIC INDIVIDUAL ITEMS BY THE DISTRICT PRIOR TO RETENTION PAYMENT (EVEN IF THERE ARE DEDUCTIONS MADE FROM RETENTION PAYMENT) WHICH REPRESENTS THE FINAL COMPLETION OF THE PROJECT.

- a. If there is no Retention remaining on the Project, individual Disputes initiated prior to Project Final Completion shall continue until a final disposition of the Arbitration or resolution of the individual Claim or Dispute.
- b. No Tolling. The Arbitration process shall not toll the Disputes or Claims process under Article 4.6 or the requirement to submit Claims to Court under Article 4.6.9.5.

4.6.7 Claims for Concealed Trenches or Excavations Greater Than Four Feet Below the Surface

When any excavation or trenching extends greater than four feet below the surface or if any condition involving hazardous substances are encountered:

- a. Immediately upon discovery, The Contractor shall promptly, and before the following conditions are disturbed, notify the District, by telephone and in writing, of the condition except:
 1. If such condition is a hazardous waste condition, Contractor's bid includes removal or disposal of hazardous substances. Material that the Contractor believes may be a material that is hazardous waste, as defined in Section 25117 of the Health and Safety Code, is required to be removed to a Class I, Class II, or Class III disposal site in accordance with the provisions of existing law. In such case, the notice bulletin procedures of Article 7 apply.
 2. Subsurface or latent physical conditions at the Site differing from those indicated in the Drawings, Specifications, Soils Report, and from Contractor's own investigation under Article 2.1.
 3. Unknown physical conditions at the Site of any unusual nature, different materially from those ordinarily encountered and generally recognized as inherent in Work of the character provided for in the Contract.

GENERAL CONDITIONS

- b. The District shall investigate the conditions, and if District finds that the conditions do materially so differ, do involve hazardous waste, and cause a decrease or increase in the Contractor's cost of, or the time required for, performance of any part of the Work shall issue a Change Order or Construction Change Document under the procedures described in the Contract.
- c. In the event that a dispute arises between the public entity or District and the Contractor whether the conditions materially differ, involve hazardous waste, or cause a decrease or increase in the Contractor's cost of, or time required for, performance of any part of the Work, the Contractor shall not be excused from any scheduled Completion Date provided for by the Contract, but shall proceed with all Work to be performed under the Contract. The Contractor shall retain any and all rights provided either by Contract or by law which pertain to the resolution of disputes and protests between the contracting parties.

4.6.8 Dispute Concerning Extension of Time.

If Contractor and District cannot agree upon an extension of time, whether compensable or not, then Contractor must have first completed the procedures set forth in Article 8.4. Upon completion of the procedures set forth under Article 8.4, Contractor must then comply with the requirements in this Article including those set forth under Article 4.6.9.

4.6.9 Claims Procedures

Pursuant to the remedies under Public Contract Code section 9201 and Government Code section 930.2, Contractor, through execution of this Agreement, also agrees to comply with the Claims requirements of Article 4.6 to quickly and efficiently resolve Disputes and Claims. Further, to provide a level of accuracy to the records submitted, the District shall have the right to audit books and records pursuant to Article 13.11 based on the actual costs incurred and to reduce the uncertainty in resolving Disputes and Claims with limited information.

4.6.9.1 *Procedure Applicable to All Claims*

- a. Definition of Claim: A "Claim" is where a Dispute between the parties rises to the level where backup documentation is assembled and provided to the District as a separate demand by the Contractor for: (1) a time extension, including, without limitation, for relief from damages or penalties for delay assessed by the District under the Contract; (2) payment by the District of money or damages arising from Work done by, or on behalf of, the Contractor pursuant to the Contract and payment for which is not otherwise expressly provided for or to which the Contractor is not otherwise entitled to; or (3) an amount of payment disputed by the District. If the Claim is for damages associated with a DSA Stop Work Order, the Contractor shall not be entitled to a request for Compensation, but shall be entitled to utilize Governmental Delay Float (See Article 8.1.4.1.)
- b. Filing Claim Is Not Basis to Discontinue Work: The Contractor shall promptly comply with Work under the Contract or Work requested by the District even though a written Claim has been filed. The Contractor and

GENERAL CONDITIONS

the District shall make good faith efforts to resolve any and all Claims that may arise during the performance of the Work covered by this Contract.

- c. Claim Notification: The Contractor shall within seven (7) calendar days after the written decision of the Architect, or if the time period for Architect's decision has passed under Article 4.6.5, submit a notification in writing sent by registered mail or certified mail with return receipt requested, with the District (and the District's CM) stating clearly the basis for the Claim and including all relevant and required documents. If the notification is not submitted within seven (7) days after the written decision of the Architect or the passage of time under Article 4.6.5, the Contractor shall be deemed to have waived all right to assert the Claim, and the Claim shall be denied. Claims submitted after the Retention Payment date shall also be considered null and void by the District. All Claims shall be reviewed pursuant to Articles 4.6.1 through 4.6.5.

The Formal Notification of Claim must be presented as follows:

- (1) The term "Claim" must be at the top of the page in no smaller than 20 point writing.
 - (2) All documentation submitted pursuant to Article 4.6 to the Architect shall be submitted with the "Claim."
 - (3) A stack of documents, copy of all Project documents, or the submission of random documents shall not constitute an adequate reference to supporting documentation.
 - (4) Any additional or supporting documentation that Contractor believes is relevant should be submitted at this time.
- d. Reasonable Documents to Support Claim: The Contractor shall furnish reasonable documentation to support the Claim. The Contractor shall provide all written detailed documentation which supports the Claim, including but not limited to: arguments, justifications, cost, estimates, Schedule analysis and detailed documentation. The format of the required reasonable documentation to support the Claim shall include, without limitation:
1. Cover letter.
 2. Summary of factual basis of Claim and amount of Claim.
 3. Summary of the basis of the Claim, including the specific clause and section under the Contract under which the Claim is made.
 4. Documents relating to the Claim, including:
 - a. Specifications sections in question.
 - b. Relevant portions of the Drawings

GENERAL CONDITIONS

- c. Applicable Clarifications (RFI's)
 - d. Other relevant information, including responses that were received.
 - e. Contractor Analysis of Claim merit.
 - (a) Contractor's analysis of any Subcontractor vendor Claims that are being passed through.
 - (b) Any analysis performed by outside consultants
 - (c) Any legal analysis that Contractor deems relevant
 - f. Break down of all costs associated with the Claim.
 - g. For Claims relating to time extensions, an analysis and supporting documentation evidencing any effect upon the critical path in conformance with the requirements of Article 8.4 chronology of events and related correspondence.
 - h. Applicable Daily Reports and logs.
 - (a) If the Daily Reports or Logs are not available, lost or destroyed, there shall be a presumption that the lost documentation was unfavorable to the Contractor. See California Civil Jury Instruction 204.
 - i. For Claims involving overhead, cost escalation, acceleration, disruption or increased costs, a full version of job costs reports organized by category of work or Schedule of Values with budget information tracked against actual costs. Any and all supporting back-up data, including the original bid (and associated original unaltered metadata).
 - (a) The metadata and bid information shall be provided confidentially and subject to a protective order to prevent dissemination to other contractors or to the public. However, the bid documentation should remain intact and available for review and inspection in case of this type of increased cost Claim.
 - (b) This data on the bid shall be made available to any District attorneys or experts and shall also be utilized as evidence for any legal proceedings.
 - (c) If the bid documentation is not available, lost or destroyed, there shall be a presumption that the lost bid documentation was unfavorable to the Contractor. See California Civil Jury Instruction 204.
- e. Certification: The Contractor (and Subcontractors, if applicable) shall submit with the Claim a certification under penalty of perjury:
- 1. That the Contractor has reviewed the Claim and that such Claim is made in good faith;

GENERAL CONDITIONS

2. Supporting data are accurate and complete to the best of the Contractor's knowledge and belief;
 3. The amount requested accurately reflects the amount of compensation for which the Contractor believes the District is liable.
 4. That the Contractor is familiar with Government Code sections 12650 et seq. and Penal Code section 72 and that false claims can lead to substantial fines and/or imprisonment.
- f. Signature of Certification: If the Contractor is not an individual, the certification shall be executed by an officer or general partner of the Contractor having overall responsibility for the conduct of the Contractor's affairs.
- g. Upon receipt of a Claim and all supporting documents as required above, the District shall conduct a reasonable review of the Claim and, within a period not to exceed 45 days, shall provide the Contractor a written statement identifying what portion of the Claim is disputed and what portion is undisputed. Upon receipt of a Claim, the District and Contractor may, by mutual agreement, extend the time period provided in this paragraph.
- h. If the District needs approval from its governing Board to provide the Contractor a written statement identifying the disputed portion and the undisputed portion of the Claim, and the governing Board does not meet within the 45 days or within the mutually agreed to extension of time following receipt of a Claim sent by registered mail or certified mail, return receipt requested, the District shall have up to three days following the next duly publicly noticed meeting of the governing Board after the 45-day period, or extension, expires to provide the Contractor a written statement identifying the disputed portion and the undisputed portion.
- i. Any payment due on an undisputed portion of the Claim shall be processed and made within 60 days after the District issues its written statement. If the District fails to issue a written statement, paragraph o below shall apply.
- j. If the Contractor disputes the District's written response, or if the District fails to respond to a Claim issued pursuant to this Article 4.6.9 within the time prescribed, the Contractor may demand in writing an informal conference to meet and confer for settlement of the issues in dispute. Upon receipt of a demand in writing sent by registered mail or certified mail, return receipt requested, the District shall schedule a meet and confer conference within 30 days for settlement of the Claim.
- k. Within 10 business days following the conclusion of the meet and confer conference, if the Claim or any portion of the Claim remains in dispute, the District shall provide the Contractor a written statement identifying the

GENERAL CONDITIONS

portion of the Claim that remains in dispute and the portion that is undisputed. Any payment due on an undisputed portion of the Claim shall be processed and made within 60 days after the District issues its written statement. Any disputed portion of the Claim, as identified by the Contractor in writing, shall be submitted to nonbinding mediation, with the District and the Contractor sharing the associated costs equally. The District and Contractor shall mutually agree to a mediator within 10 business days after the disputed portion of the Claim has been identified in writing. If the parties cannot agree upon a mediator, each party shall select a mediator and those mediators shall select a qualified neutral third party to mediate with regard to the disputed portion of the Claim. Each party shall bear the fees and costs charged by its respective mediator in connection with the selection of the neutral mediator. If mediation is unsuccessful, the parts of the Claim remaining in dispute shall be subject to applicable procedures in Article 4.6.9.5.

- l. For purposes of this Article 4.6.9, mediation includes any nonbinding process, including, but not limited to, neutral evaluation or a dispute review board, in which an independent third party or board assists the parties in dispute resolution through negotiation or by issuance of an evaluation. Any mediation utilized shall conform to the timeframes in this section.
- m. Unless otherwise agreed to by the District and the Contractor in writing, the mediation conducted pursuant to this Article 4.6.9 shall excuse any further obligation under Section 20104.4 to mediate after litigation has been commenced.
- n. This Claims process does not preclude the District from requiring arbitration of disputes under private arbitration or the Public Works Contract Arbitration Program, if mediation under this Article 4.6.9 does not resolve the parties' Claim. This Claims process does not preclude the District from submitting individual Disputes or Claims to binding arbitration pursuant to Article 4.6.9.4 below.
- o. Failure by the District to respond to a Claim from the Contractor within the time periods described in this subdivision or to otherwise meet the time requirements of this Article 4.6.9 shall result in the Claim being deemed rejected in its entirety. A Claim that is denied by reason of the District's failure to have responded to a Claim, or its failure to otherwise meet the time requirements of this Article 4.6.9, shall not constitute an adverse finding with regard to the merits of the Claim or the responsibility or qualifications of the Contractor.
- p. If a subcontractor or a lower tier subcontractor lacks legal standing to assert a Claim against a District because privity of contract does not exist, the Contractor may present to the District a Claim on behalf of a subcontractor or lower tier subcontractor. A subcontractor may request in writing, either on his or her own behalf or on behalf of a lower tier subcontractor, that the Contractor present a Claim for work which was

GENERAL CONDITIONS

performed by the subcontractor or by a lower tier subcontractor on behalf of the subcontractor. The subcontractor requesting that the Claim be presented to the District shall furnish reasonable documentation to support the Claim. Within 45 days of receipt of this written request, the Contractor shall notify the subcontractor in writing as to whether the Contractor presented the Claim to the District and, if the Contractor did not present the Claim, provide the subcontractor with a statement of the reasons for not having done so.

- q. Upon receipt of a Claim, the parties may mutually agree to waive, in writing, mediation and proceed directly to the commencement of a civil action or binding arbitration, as applicable.
- r. The Contractor's Claim shall be denied if it fails to follow the requirements of this Article.

4.6.9.2 *District (through CM or District's Agent or Attorney) May Request Additional Information.* Within thirty (30) days of receipt of the Claim and the information under this Article, the District may request in writing any additional documentation supporting the Claim or documentation relating to defenses to the Claim which the District may assert. If additional documents are required, the time in which the Claim is evaluated may be extended by a reasonable time so the Claim and additional documents may be reviewed.

4.6.9.3 *Claims Procedures in Addition to Government Code Claim.* Nothing in the Claims procedures set forth in this Article 4 of the General Conditions shall act to waive or relieve the Contractor from meeting the requirements set forth in Government Code section 900 et seq.

4.6.9.4 *Binding Arbitration of Individual Claim Issues.* To expedite resolution of Claims pursuant to Public Contract Code section 9201, at the District's sole option, the District may submit individual Claims to Arbitration prior to Retention Payment consistent with the requirements of Article 4.6.6.1.

4.6.9.5 *Resolution of Claims in Court of Competent Jurisdiction.* If Claims are not resolved under the procedure set forth and pursuant to Article 4.6.9, such Claim or controversy shall be submitted to a court in the County of the location of the Project after the Project has been completed, and not before.

4.6.9.6 *Warranties, Guarantees and Obligations.* The duties and obligations imposed by these General Conditions and the rights and remedies available hereunder to the parties hereto, and, in particular but without limitation, the warranties, guarantees and obligations imposed upon Contractor by the General Conditions and amendments thereto; and all of the rights and remedies available to District and Architect thereunder, are in addition to, and are not to be construed in any way as a limitation of, any rights and remedies available to any or all of them which are otherwise imposed or available by laws or regulations by special warranty or guarantee or by other provisions of the Contract Documents, and the provisions of this Article will be as effective as if repeated specifically in the Contract Documents in connection with each particular duty, obligation, right and remedy to which they apply.

GENERAL CONDITIONS

ARTICLE 5 SUBCONTRACTORS

5.1 DEFINITIONS

5.1.1 Subcontractual Relations Bound to Same Contract Terms at General Contractor

By appropriate agreement, written where legally required for validity, the Contractor shall require each Subcontractor, to the extent of the Work to be performed by the Subcontractor, to be bound to the Contractor by terms of the Contract Documents, and to assume toward the Contractor all the same obligations and responsibilities, assumed by Contractor pursuant to the Contract Documents. Each subcontract agreement shall preserve and protect the rights of the District and the Architect under the Contract Documents with respect to the Work to be performed by the Subcontractor so that subcontracting thereof will not prejudice such rights. Where appropriate, the Contractor shall require each Subcontractor to enter into similar agreements with Sub-subcontractors. The Contractor shall make available to each proposed Subcontractor, prior to the execution of the subcontract agreement, copies of the Contract Documents to which the Subcontractor will be bound. Upon written request of the Subcontractor, the Contractor shall identify to the Subcontractor the terms and conditions of the proposed subcontract agreement, which may be at variance with the Contract Documents. Subcontractors shall similarly make copies of applicable portions of such documents available to their respective proposed Sub-subcontractors.

5.1.2 Subcontractor Licenses and DIR Registration

All Subcontractors shall be properly licensed by the California State Licensing Board. All Subcontractors (of any tier) performing any portion of the Work must comply with the Labor Code sections 1725.5 and 1771.1 and must be properly and currently registered with the California Department of Industrial Relations and qualified to perform public works pursuant to Labor Code section 1725.5 throughout the duration of the Project. No portion of the Work is permitted to be performed by a Subcontractor of any tier unless the subcontractor is properly registered with DIR. Any Subcontractors of any tier not properly registered with DIR shall be substituted in accordance with Labor Code section 1771.1.

5.1.3 Substitution of Subcontractor

Substitution of Subcontractors shall be permitted only as authorized under Public Contract Code §§ 4107 et seq. Any substitutions of Subcontractors shall not result in any increase in the Contract Price or result in the granting of any extension of time for the completion of the Project.

5.1.4 Contingent Assignment of Subcontracts and Other Contracts

Each subcontract, purchase order, vendor contract or agreement for any portion of the Work is hereby assigned by the Contractor to the District provided that:

- a. Such assignment is effective only after Termination of this Contract with the Contractor by the District as provided under Article 14 and only for those subcontracts and other contracts and agreements that the District accepts by notifying the Subcontractor or Materialman (as may be applicable) in writing; and
- b. Such assignment is subject to the prior rights of the Surety(ies) obligated under the Payment Bond and Performance Bond.

GENERAL CONDITIONS

- c. The Contractor shall include adequate provisions for this contingent assignment of subcontracts and other contracts and agreements in each such document.

GENERAL CONDITIONS

ARTICLE 6 CONSTRUCTION BY DISTRICT OR BY SEPARATE CONTRACTORS

6.1 DISTRICT'S RIGHT TO PERFORM CONSTRUCTION AND TO AWARD SEPARATE CONTRACTS

6.1.1 Separate Contracts.

6.1.1.1 District reserves the right to let other contracts in connection with this Work. Contractor shall afford other contractors reasonable opportunity for (1) introduction and storage of their materials; (2) access to the Work; and (3) execution of their work. Contractor shall properly connect and coordinate its work with that of other Contractors.

6.1.1.2 If any part of Contractor's Work depends on proper execution or results of any other contractor, the Contractor shall inspect and within seven (7) days or less, report to Architect, in writing, any defects in such work that render it unsuitable for proper execution of Contractor's Work. Contractor will be held accountable for damages to District for that Work which it failed to inspect or should have inspected. Contractor's failure to inspect and report shall constitute its acceptance of other contractors' Work as fit and proper for reception of its Work, except as to defects which may develop in other contractors' work after execution of Contractor's work.

6.1.1.3 To ensure proper execution of its subsequent Work, Contractor shall measure and inspect Work already in place and shall at once report to the Architect in writing any discrepancy between executed Work as built and the Contract Documents.

6.1.1.4 Contractor shall ascertain to its own satisfaction the scope of the Project and nature of any other contracts that have been or may be awarded by District in prosecution of the Project and the potential impact of such Work on the Baseline Schedule or Schedule updates.

6.1.1.5 Nothing herein contained shall be interpreted as granting to Contractor the exclusive occupancy at the site of Project. Contractor shall not cause any unnecessary hindrance or delay to any other contractor working on the Project Site. If execution of any contract by the District is likely to cause interference with Contractor's performance of this Contract, once Contractor provides District timely written notice and identifies the Schedule Conflict, District shall decide which contractor shall cease work temporarily and which contractor shall continue, or whether Work can be coordinated so that contractors may proceed simultaneously.

6.1.1.6 District shall not be responsible for any damages suffered or extra costs incurred by Contractor resulting directly or indirectly from award or performance or attempted performance of any other contract or contracts at the Project necessary for the performance of the Project (examples include Electrical Utility Contractor, separate offsite contractor, a separate grading contractor, furniture installation etc.)

CONTRACTOR IS AWARE THAT THIS CONTRACT MAY BE SPLIT INTO SEVERAL PHASES BASED ON DOCUMENTATION PROVIDED WITH THIS BID OR DISCUSSED AT THE JOB WALK. CONTRACTOR HAS MADE ALLOWANCE FOR ANY DELAYS OR DAMAGES WHICH MAY ARISE FROM COORDINATION WITH CONTRACTORS REQUIRED FOR OTHER PHASES.

GENERAL CONDITIONS

IF ANY DELAYS SHOULD ARISE FROM ANOTHER CONTRACTOR WORKING ON A DIFFERENT PHASE, CONTRACTOR'S SOLE REMEDY FOR DAMAGES, INCLUDING DELAY DAMAGES, SHALL BE AGAINST THE CONTRACTOR WHO CAUSED SUCH DAMAGE AND NOT THE DISTRICT. CONTRACTOR SHALL PROVIDE ACCESS TO OTHER CONTRACTORS FOR OTHER PHASES AS NECESSARY TO PREVENT DELAYS AND DAMAGES TO OTHER CONTRACTORS WORKING ON OTHER PHASES OF CONSTRUCTION.

6.1.2 District's Right to Carry Out the Work

(See Article 2.2)

6.1.3 Designation as Contractor

When separate contracts are awarded to contractors on the Project Site, the term "Contractor" in the Contract Documents in each case shall mean the Contractor who executes each separate District/Contractor Agreement.

6.1.4 District Notice to the Contractor of Other Contractors

The Contractor shall have overall responsibility to reasonably coordinate and schedule Contractor's activities with the activities of the District's forces and of each separate contractor with the Work of the Contractor, who shall cooperate with them. The Contractor shall participate with other separate contractors and the District in reviewing their construction schedules when:

- a. Notice is provided in the Contract Documents of other scope of Work,
- b. In the case where there is known Work to be performed by other Contractors
- c. For outside contractors hired by utilities
- d. Where the Contract Document provides "Work by Others" or "By Others"
- e. Where specifically noted during the Pre-Bid Conference
- f. Where specifically noted in the Mandatory Job Walk
- g. By CO or ICD,
- h. With respect to the installation of :
 1. Furniture,
 2. Electronics and networking equipment,
 3. Cabling,
 4. Low voltage,
 5. Off-site work,
 6. Grading (when by a separate contractor),
 7. Environmental remediation when excluded by the Contract Documents (i.e. asbestos, lead or other hazardous waste removal)

GENERAL CONDITIONS

8. Deep cleaning crews,
9. Commissioning and testing,
10. Keying and re-keying,
11. Programming

6.1.4.1 **Exception where no Coordination is Required on the Part of the Contractor for Turn Key Operations.** If the Contractor has specifically outlined a “Turn Key” or “Complete Delivery” of a final completed operational school in writing as part of the Baseline Schedule..

6.1.4.2 The Contractor shall make any revisions to the Baseline Schedule (or Schedule Update) and Contract Sum deemed necessary after a joint review and mutual agreement. The Baseline Schedule (or Schedule Update) shall then constitute the Schedules to be used by the Contractor, separate contractors, and the District until subsequently revised. Additionally, Contractor shall coordinate with Architect, District, and Inspector to ensure timely and proper progress of Work.

6.2 CONSTRUCTIVE OWNERSHIP OF PROJECT SITE AND MATERIAL

Upon commencement of Work, the Contractor becomes the constructive owner of the entire site, improvements, material and equipment on Project site. Contractor must ensure proper safety and storage of all materials and assumes responsibility as if Contractor was the owner of the Project site. All risk of loss or damage shall be borne by Contractor during the Work until the date of Completion. As constructive owner of the Project site, Contractor must carry adequate insurance in case of calamity and is not entitled to rely on the insurance requirements as set forth in this Agreement as being adequate coverage in case of calamity.

6.3 DISTRICT’S RIGHT TO CLEAN UP

If a dispute arises among the Contractor, separate contractors, and the District as to the responsibility under their respective contracts for maintaining the premises and surrounding area free from waste materials and rubbish as described in Article ARTICLE 1, the District may clean up and allocate the cost among those it deems responsible.

GENERAL CONDITIONS

ARTICLE 7 CHANGES IN THE WORK

7.1 CHANGES

7.1.1 No Changes Without Authorization

There shall be no change whatsoever in the Drawings, Specifications, or in the Work without an executed Change Order, Change Order Request, Immediate Change Directive, or order by the Architect for a minor change in the Work as herein provided. District shall not be liable for the cost of any extra work or any substitutions, changes, additions, omissions, or deviations from the Drawings and Specifications unless the District's Governing Board or designated representative with delegated authority (subject to Board ratification) has authorized the same and the cost thereof approved in writing by Change Order or executed Construction Change Document. No extension of time for performance of the Work shall be allowed hereunder unless claim for such extension is made at the time changes in the Work are ordered, and such time duly adjusted in writing in the Change Order. The provisions of the Contract Documents shall apply to all such changes, additions, and omissions with the same effect as if originally embodied in the Drawings and Specifications. Notwithstanding anything to the contrary in this Article 7, all Change Orders shall be prepared and issued by the Architect and shall become effective when executed by the District's Governing Board, the Architect, and the Contractor.

Should any Change Order result in an increase in the Contract Price, the cost of such Change Order shall be agreed to, in writing, in advance by Contractor and District and be subject to the monetary limitations set forth in Public Contract Code section 20118.4 (Please check with the District since there are different interpretations of the limitations of Public Contract Code section 20118.4 depending on the County the Project is located). In the event that Contractor proceeds with any change in Work without first notifying District and obtaining the Architect's and District's consent to a Change Order, Contractor waives any Claim of additional compensation for such additional work and Contractor takes the risk that a Notice of Non-Compliance may issue, a critical path Project delay may occur, and the Contractor will also be responsible for the cost of preparation and DSA CCD review fees for a corrective DSA approved Construction Change Document.

CONTRACTOR UNDERSTANDS, ACKNOWLEDGES, AND AGREES THAT THE REASON FOR THIS NOTICE REQUIREMENT IS SO THAT DISTRICT MAY HAVE AN OPPORTUNITY TO ANALYZE THE WORK AND DECIDE WHETHER THE DISTRICT SHALL PROCEED WITH THE CHANGE ORDER OR ALTER THE PROJECT SO THAT SUCH CHANGE IN WORK BECOMES UNNECESSARY AND TO AVOID THE POSSIBLE DELAYS ASSOCIATED WITH THE ISSUANCE OF A NOTICE OF NON-COMPLIANCE.

7.1.2 Notices of Non-Compliance

Contractor deviation or changes from approved Plans and Specifications may result in the issuance of a Notice of Non-Compliance (See DSA Form 154). Contractor is specifically notified that deviations from the Plans and Specifications, whether major or minor, may result in the requirement to obtain a DSA Construction Change Document to correct the Notice of Non-Compliance. (See Article 7.3.1 for Definition of CCD). In some cases, the lack of a DSA approved CCD AND verification from the Inspector that a Notice of Non-Compliance has been corrected may result in a critical path delay to the next stage of Work on the Project. Specifically, a deviation from approved Plans and Specifications may prevent

GENERAL CONDITIONS

approval of the category of Work listed in the DSA 152 Project Inspection Card. Any delays that are caused by the Contractor's deviation from approved Plans and Specifications shall be the Contractor's responsibility.

7.1.3 Architect Authority

The Architect will have authority to order minor changes in the Work that do not involve DSA Approval not involving any adjustment in the Contract Sum, or an extension of the Contract Time.

7.2 **CHANGE ORDERS ("CO")**

A CO is a written instrument prepared by the Architect and signed by the District (as authorized by the District's Governing Board), the Contractor, and the Architect stating their agreement upon all of the following:

- a. A description of a change in the Work;
- b. The amount of the adjustment in the Contract Sum, if any; and
- c. The extent of the adjustment in the Contract Time, if any.

A CO may be comprised of ICD's, Response to RFP's and COR's

7.3 **CONSTRUCTION CHANGE DOCUMENT (CCD Category A, and CCD Category B) and WORK DIRECTIVE (WD)**

7.3.1 Definitions

7.3.1.1 *Construction Change Document (CCD)*. A Construction Change Document is a DSA term that is utilized to address changes to the DSA approved Plans and Specifications. There are two types of Construction Change Documents. (1) DSA approved CCD Category A for Work affecting structural, access compliance or fire/ life safety of the Project which will require a DSA approval; and, (2) CCD Category B for work NOT affecting structural safety, access compliance or fire/ life safety that will not require a DSA approval (except to confirm that no approval is required). Both CCD Category A and Category B shall be set forth in DSA Form 140 and submitted to DSA as required.

7.3.1.2 *Work Directive (ICD)*. A Work Directive is a written order to the Contractor prepared by the Architect and signed by the District (and CM if there is a CM on the Project) and the Architect, directing a change in the Work and stating a proposed basis for adjustment, if any, in the Contract Sum or Contract Time, or both. The District may by WD, without invalidating the Contract, direct immediate changes in the Work within the general scope of the Contract consisting of additions, deletions, or other revisions within. If applicable, the Contract Sum and Contract Time will be adjusted accordingly.

In the case of an Work Directive being issued, Contractor must commence Work immediately or delays from failure to perform the WD shall be the responsibility of Contractor and the failure to move forward with Work immediately shall also be grounds for Termination under Article 14.

A WD does not automatically trigger an Article 7.6 Dispute or Claim. Contractor must timely follow the procedures outlined at Article 7.6 and 4.6 where applicable.

GENERAL CONDITIONS

Refer to Division 1 and Supplementary General Conditions for a copy of the proposed Immediate Change Directive form.

7.3.2 Use to Direct Change

A WD shall be used to move work forward immediately and to avoid delay. In some cases, a WD shall be issued in the absence of agreement on the terms of a CO, COR, or RFP. A copy of an ICD form is provided in the Supplementary General Conditions and Division 1. The anticipated not to exceed price for the Work will be inserted into the WD. In the case of an WD issued to correct Contractor Deficiencies or to correct a Contractor caused Notice of Non-Compliance, the WD may be issued with \$0 and no additional time. Contract may prepare a COR associated with the WD pursuant to Article 7. However, Contractor shall proceed with all Work required under an Approved WD immediately upon issuance. Failure to proceed with the Work under an WD shall be grounds for Termination for Cause under Article 14 or take over the Work under Article 2.2.

If adequate time exists, a WD may be subject of an RFP for pricing and determination if any time that may be required. However, if an RFP is not completed, Contractor shall immediately commence Work when a WD is issued. If the RFP is incomplete, it may still be completed to be submitted for pricing purposes as long as the RFP is submitted within the timeline provided by the RFP, or within 10 days following issuance of the WD.

7.3.3 WD Issued Over a Notice of Non-Compliance or to Cover Work Subject to a DSA 152 Sign Off

In some cases, an WD shall be for the purpose of proceeding with Work to keep the Project on Schedule and as an acknowledgement by the District that Contractor is proceeding with Work contrary to a Notice of Non-Compliance, prior to issuance of a DSA approved CCD Category A, or to direct the covering of Work which has not yet received a DSA 152 Inspection Approval to move forward.

7.3.3.1 *Contractor Compliance with all Aspects of a WD.* Contractor is to undertake the WD and comply with all aspects of the Work outlined in the WD. Inspector is to inspect the Work pursuant to the WD. Failure to follow the WD may result in deduction of the ICD Work under Article 2.2 or Termination of the Contractor pursuant to Article 14.

7.3.3.2 *Exception in the Case of DSA Issued Stop Work Order.* Contractor must proceed with an WD even if a CCD has not been approved by DSA except in the case of a DSA issued Stop Work Order. If a DSA Stop Work Order is issued, Contractor must stop work and wait further direction from the District.

7.3.3.3 *WD Due to Contractor Deficiency or Contractor Caused Notice of Non-Compliance.* If a WD is issued to correct a Contractor Deficiency or a Contractor caused notice of Non-Compliance, Contractor specifically acknowledges responsibility for all consequential damages associated with the Contractor Deficiency or Contractor caused Notice of Non-Compliance and all consequential damages and costs incurred to correct the deficiency under Article 4.5

7.4 REQUEST FOR INFORMATION (“RFI”)

7.4.1 Definition

A RFI is a written request prepared by the Contractor requesting the Architect to provide additional information necessary to clarify or amplify an item which the Contractor believes is not clearly

GENERAL CONDITIONS

shown or called for in the Drawings or Specifications, or to address problems which have arisen under field conditions.

7.4.1.1 A RFI shall not be used as a vehicle to generate time extensions.

7.4.1.2 Resubmission of the same or similar RFI is not acceptable. RFI's that are similar should be addressed in Project meetings where the requestor (Contractor, Subcontractor or vendor) is able to address the particular issue with the Architect or Engineer and a resolution addressed in the minutes.

7.4.1.3 A RFI response applicable to a specific area cannot be extended to other situations unless specifically addressed in writing within the RFI or in a separate RFI.

7.4.1.4 RFI's should provide a proposed solution and should adequately describe the problem that has arisen.

7.4.2 Scope

The RFI shall reference all the applicable Contract Documents including Specification section, detail, page numbers, Drawing numbers, and sheet numbers, etc. The Contractor shall make suggestions and interpretations of the issue raised by the RFI. An RFI cannot modify the Contract Cost, Contract Time, or the Contract Documents.

7.4.3 Response Time

The Architect must respond to a RFI within a reasonable time after receiving such request. If the Architect's response results in a change in the Work, then such change shall be effected by a written CO, COR RFP or WD, if appropriate. If the Architect cannot respond to the RFI within a reasonable time, the Architect shall notify the Contractor, with a copy to the Inspector and the District, of the amount of time that will be required to respond.

7.4.4 Costs Incurred

The Contractor shall be responsible for any costs incurred for professional services as more fully set forth in Article 4.5, which shall be subject to a Deductive Change Order, if an RFI requests an interpretation or decision of a matter where the information sought is equally available to the party making such request. District, at its sole discretion, shall issue a Deductive Change Order to Contractor for all such professional services arising from this Article.

7.5 **REQUEST FOR PROPOSAL ("RFP")**

7.5.1 Definition

A RFP is a written request prepared by the Architect (and/or CM) requesting the Contractor to submit to the District and the Architect an estimate of the effect of a proposed change on the Contract Price and (if applicable) the Contract Time. If Architect issues a Bulletin, the Changed items in the Bulletin shall be addressed as an RFP and all responses shall be prepared to a Bulletin as addressed in this Article 7.5. A form RFP is included in the Division 1 documents.

7.5.2 Scope

GENERAL CONDITIONS

A RFP shall contain adequate information, including any necessary Drawings and Specifications, to enable Contractor to provide the cost breakdowns required by Article 7.7. The Contractor shall not be entitled to any Additional Compensation for preparing a response to an RFP, whether ultimately accepted or not.

7.5.3 Response Time

Contractor shall respond to an RFP within ten (10) days or the time period otherwise set forth in the RFP.

7.6 **CHANGE ORDER REQUEST (“COR”)**

7.6.1 Definition

A COR is a written request prepared by the Contractor supported by backup documentation requesting that the District and the Architect issue a CO based upon a proposed change, cost, time, or cost and time that may be incurred on the Project or arising from an RFP, WD, or CCD.

7.6.2 Changes in Price

A COR shall include breakdowns per Article 7.7 to validate any change in Contract Price due to proposed change or Claim.

7.6.3 Changes in Time

A COR shall also include any additional time required to complete the Project only if the delay is a critical path delay. Any additional time requested shall not be the number of days to make the proposed change, but must be based upon the impact to the Project Schedule as defined in Article 8. A schedule fragnet showing the time delay must be submitted with the COR. Any changes in time will be granted only if there is an impact to the critical path. If Contractor fails to request a time extension in a COR, then the Contractor is thereafter precluded from requesting or claiming a delay.

7.7 **COST OF CHANGE ORDERS**

7.7.1 Scope

Within ten (10) days after a request is made for a change that impacts the Contract Sum as defined in Article 9.1, the critical path, or the Contract Time as defined in Article 8.1.1, the Contractor shall provide the District and the Architect, with a written estimate of the effect of the proposed CO upon the Contract Sum and the actual cost of construction, which shall include a complete itemized cost breakdown of all labor and material showing actual quantities, hours, unit prices, and wage rates required for the change, and the effect upon the Contract Time of such CO. Changes may be made by District by an appropriate written CO, or, at the District’s option, such changes shall be implemented immediately upon the Contractor’s receipt of an appropriate written Construction Change Document.

District may, as provided by law and without affecting the validity of this Agreement, order changes, modification, deletions and extra work by issuance of written CO or CCD from time to time during the progress of the Project, Contract Sum being adjusted accordingly. All such Work shall be executed under conditions of the original Agreement except that any extension of time caused thereby shall be adjusted at time of ordering such change. District has discretion to order changes on a “time and material”

GENERAL CONDITIONS

basis with adjustments to time made after Contractor has justified through documentation the impact on the critical path of the Project.

7.7.1.1 *Time and Material Charges.* If the District orders Work on a “time and material” basis, timesheets shall be signed daily by the Inspector or District Representative at or near the time the Work is actually undertaken and shall show the hours worked, and the Work actually completed. No time sheets shall be signed the next day. A copy shall be provided to the Person signing the document at the time the document is signed, but not before 10 am the following day.

7.7.2 Determination of Cost

The amount of the increase or decrease in the Contract Price from a CO or COR, if any, shall be determined in one or more of the following ways as applicable to a specific situation:

- a. Mutual acceptance of a lump sum properly itemized and supported by sufficient substantiating data to permit evaluation. If an agreement cannot be reached within fifteen (15) days after submission and negotiation of Contractor’s proposal, Contractor may submit pursuant to Article 7.7.3. Submission of sums which have no basis in fact are at the sole risk of Contractor and may be a violation of the False Claims Act set forth under Government Code section 12650 et seq.);
 1. If the District objects to 7.7.2(a) as a method for submission due to inaccuracies in the submitted amount, overstatement of manpower or time required to perform the CO, or unreliability of the data provided, the District may either have the Architect or a professional estimator determine the cost for the CO, and the applicable time extension, or the Contractor shall utilize Article 7.7.2(d) or 7.7.3.
 2. Once the District provides a written objection to use of Article 7.7.2(a) due to unreliability of the estimated price, the Contractor shall no longer utilize mutual acceptance of a lump sum as a method for submission of CO’s and shall provide a breakdown of estimated or actual costs pursuant to Article 7.7.2(d) or 7.7.3
- b. By unit prices contained in Contractor’s original bid and incorporated in the Project documents or fixed by subsequent agreement between District and Contractor;
- c. Cost to be determined in a manner agreed upon by the parties and a mutually acceptable fixed or percentage fee. However, in the case of disagreement, Contractor must utilize the procedure under Article 7.7.3; or
- d. By cost of material and labor and percentage of overhead and profit. If the value is determined by this method the following requirements shall apply:
 1. *Basis for Establishing Costs*
 - (1) Labor will be the cost for wages prevailing locally for each craft or type of workers at the time the extra Work is done, plus employer payments of payroll taxes and workers compensation

GENERAL CONDITIONS

insurance (exclude insurance costs as part of the overhead and profit mark-up), health and welfare, pension, vacation, apprenticeship funds, and other direct costs resulting from Federal, State, or local laws, as well as assessments or benefits required by lawful collective bargaining agreements. In no case shall the total labor costs exceed the applicable prevailing wage rate for that particular classification. The use of a labor classification which would increase the extra Work cost will not be permitted unless the Contractor establishes the necessity for such additional costs. Labor costs for equipment operators and helpers shall be reported only when such costs are not included in the invoice for equipment rental.

- (2) Materials shall be at invoice or lowest current price at which such materials are locally available and delivered to the Site in the quantities involved, plus sales tax, freight, and delivery. The District reserves the right to approve materials and sources of supply or to supply materials to the Contractor if necessary for the progress of the Work. No markup shall be applied to any material provided by the District.
- (3) Tool and Equipment Rental. No payment will be made for the use of tools which have a replacement value of \$250 or less.

Regardless of ownership, the rates to be used in determining equipment rental costs shall not exceed listed rates prevailing locally at equipment rental agencies or distributors at the time the Work is performed. Rates applied shall be appropriate based on actual equipment need and usage. Monthly, weekly or other extended use rates that results in the lowest cost shall be applied if equipment is used on site for extended periods.

The rental rates paid shall include the cost of fuel, oil, lubrication, supplies, small tools, necessary attachments, repairs and maintenance of any kind, depreciation, storage, insurance, and all incidentals.

Necessary loading and transportation costs for equipment used on the extra Work shall be included. If equipment is used intermittently and, when not in use, could be returned to its rental source at less expense to the District than holding it at the Work Site, it shall be returned unless the Contractor elects to keep it at the Work Site at no expense to the District.

All equipment shall be acceptable to the Inspector, in good working condition, and suitable for the purpose for which it is to be used. Manufacturer's ratings and modifications shall be used to classify equipment, and equipment shall be powered by a unit of at least the minimum rating recommended by the manufacturer.

If tool and equipment charges are part of a Dispute, Claim, or Appeal, the District reserves the right to utilize actual costs for tools and

GENERAL CONDITIONS

equipment or a depreciation rate for equipment based on audit finding under Article 13.11 and deduct any rental charges that exceed actual or depreciated costs.

- e. Other Items. The District may authorize other items which may be required on the extra work. Such items include labor, services, material, and equipment which are different in their nature from those required by the Work, and which are of a type not ordinarily available from the Contractor or any of the Subcontractors. Invoices covering all such items in detail shall be submitted with the request for payment.
- f. Invoices. Vendors' invoices for material, equipment rental, and other expenditures shall be submitted with the COR. If the request for payment is not substantiated by invoices or other documentation, the District may establish the cost of the item involved at the lowest price which was current at the time of the Daily Report.
- g. Overhead. Overhead, including direct and indirect costs, shall be submitted with the COR and include: field overhead, home office overhead, off-site supervision, CO preparation/negotiation/research, time delays, Project interference and disruption, additional guaranty and warranty durations, on-site supervision, additional temporary protection, additional temporary utilities, additional material handling costs, liability and property damage insurance, and additional safety equipment costs.

7.7.3 Format for COR or CO's

The following format shall be used as applicable by the District and the Contractor to communicate proposed additions to the Contract. All costs submitted shall be actual costs and labor shall be unburdened labor. Refer to Division 1 for a copy of the Construction Change Order form.

| | <u>EXTRA</u> | <u>CREDIT</u> |
|---|--------------|---------------|
| (a) Material (attach itemized quantity and unit cost plus sales tax) | _____ | _____ |
| (b) Labor Not to Exceed Applicable Prevailing Wage Rates (attach itemized hours and rates) | _____ | _____ |
| (c) Equipment (attach invoices) | _____ | _____ |
| (d) Subtotal | _____ | _____ |
| (e) If Subcontractor performed work, add Subcontractor's overhead and profit to portions performed by Subcontractor, not to exceed 10% of item (d). | _____ | _____ |
| (f) Subtotal | _____ | _____ |

GENERAL CONDITIONS

| | | <u>EXTRA</u> | <u>CREDIT</u> |
|-----|---|--------------|---------------|
| (g) | Contractor's Overhead and Profit: Not to exceed 10% of Item (d) if Contractor performed the work. No more than 5% of Item (d) if Subcontractor performed the work. If work was performed by Contractor and Subcontractors, portions performed by Contractor shall not exceed 10% of Item (d), and portions performed by Subcontractor shall not exceed 10% of Item (d). | | |
| (h) | Subtotal | | |
| (i) | Bond not to exceed one percent (1%) of Item (h) | | |
| (k) | TOTAL | | |
| (l) | Time/ Days | | |

The undersigned Contractor approves the foregoing Change Order or Immediate Change Directive as to the changes, if any, and the Contract price specified for each item and as to the extension of time allowed, if any, for completion of the entire Work on account of said Change Order or Immediate Change Directive, and agrees to furnish all labor, materials and service and perform all Work necessary to complete any additional Work specified therein, for the consideration stated herein. It is understood that said Change Order or Immediate Change Directive shall be effective when approved by the Governing Board of the District.

It is expressly understood that the value of such extra Work or changes, as determined by any of the aforementioned methods, expressly includes any and all of the Contractor's costs and expenses, both direct and indirect, resulting from additional time required on the Project or resulting from delay to the Project. Any costs, expenses, damages or time extensions not included are deemed waived.

The Contractor expressly acknowledges and agrees that any change in the Work performed shall not be deemed to constitute a delay or other basis for claiming additional compensation based on theories including, but not limited to, acceleration, suspension or disruption to the Project.

7.7.3.1 *Adjustment for Time and Compensable Delay.* A CO shall also include any additional time required to complete the Project. Any additional time requested shall not be the number of days to make the proposed change, but must be based upon the impact to the Project Schedule as defined in Article 8 of the General Contract. A schedule fragnet showing the time delay must be submitted with the CO. Any changes in time will be granted only if there is an impact to the critical path. If Contractor fails to request a time extension in a CO, then the Contractor is thereafter precluded from requesting or claiming a delay.

7.7.4 Deductive Change Orders

GENERAL CONDITIONS

All Deductive Change Order(s) must be prepared utilizing the form under Article 7.7.3 (a) – (d) only, setting forth the actual costs incurred. Except in the case of an Article 2.2 or 9.6 Deductive Change Order where no mark-up shall be allowed, Contractor will be allowed a maximum of 5% total profit and overhead.

For unilateral Deductive Change Orders, or where credits are due from Contractor for Allowances, Deductive Items, Inspection, Damage, DSA CCD review costs, Architect or Inspector costs for after hours or corrective services, Work removed from the Agreement under Article 2.2 or Article 9.6, there shall be no mark-up.

District may, any time after a Deductive Change Order is presented to Contractor by District for items under Article 2.2 or Article 9.6 or if there is disagreement as to the Deductive Change Order, issue a unilateral Deductive Change Order on the Project and deduct the Deductive Change Order from a Progress Payment, Final Payment, or Retention.

7.7.5 Discounts, Rebates, and Refunds

For purposes of determining the cost, if any, of any change, addition, or omission to the Work hereunder, all trade discounts, rebates, refunds, and all returns from the sale of surplus materials and equipment shall accrue and be credited to the Contractor, and the Contractor shall make provisions so that such discounts, rebates, refunds, and returns may be secured, and the amount thereof shall be allowed as a reduction of the Contractor's cost in determining the actual cost of construction for purposes of any change, addition, or omissions in the Work as provided herein. All CO's are subject to Audit under Article 13.11 for discounts, rebates and refunds.

7.7.6 Accounting Records

With respect to portions of the Work performed by CO's and CCD's on a time-and-materials, unit-cost, or similar basis, the Contractor shall keep and maintain cost-accounting records in a format consistent with accepted accounting standards and satisfactory to the District, which shall be available to the District on the same terms as any other books and records the Contractor is required to maintain under the Contract Documents.

Any time and material charges shall require Inspector's signature on time and material cards showing the hours worked and the Work actually completed. (See Article 7.7.1.1)

7.7.7 Notice Required

If the Contractor desires to initiate a Dispute for an increase in the Contract Price, or any extension in the Contract Time for completion, Contractor shall notify the applicable party responsible for addressing the Dispute or Claim pursuant to Article 4.6. No Claim or Dispute shall be considered unless made in accordance with this subparagraph. Contractor shall proceed to execute the Work even though the adjustment may not have been agreed upon. Any change in the Contract Price or extension of the Contract Time resulting from such Claim shall be authorized by a CO.

7.7.8 Applicability to Subcontractors

Any requirements under this Article 7 shall be equally applicable to CO's, COR's or ICD's issued to Subcontractors by the Contractor to the same extent required by the Contractor.

GENERAL CONDITIONS

7.7.9 Alteration to Change Order Language

Contractor shall not alter or reserve time in COR's, CO's or WD's. Contractor shall execute finalized CO's and proceed under Article 7.7.7 and Article 4.6 with proper notice. If Contractor intends to reserve time without an approved CPM schedule prepared pursuant to Article 8 or without submitting a fragnet showing delay to critical path, then Contractor may be prosecuted pursuant to the False Claim Act.

GENERAL CONDITIONS

ARTICLE 8 TIME AND SCHEDULE

8.1 **DEFINITIONS**

8.1.1 **Contract Time**

Contractor shall perform and reach Substantial Completion (See Article 1.1.46) within the time specified in the Agreement Form. Moreover, Contractor shall perform its Work in strict accordance with the Project Milestones in the Contract Documents and shall proceed on a properly developed and approved Baseline Schedule, which represents the Contractor's view of the practical way in which the Work will be accomplished. Note that Contract Time includes and incorporates all Float and other Baseline inclusions as noted in Article 8.3.2.1 and as otherwise specifically noted in Article 8.

8.1.2 **Notice to Proceed**

District may give a Notice to Proceed within ninety (90) days of the award of the bid by District. Once Contractor has received the notice to proceed, Contractor shall complete the Work in the period of time referenced in the Contract Documents.

In the event that District desires to postpone the giving of the Notice to Proceed beyond this three-month period, it is expressly understood that with reasonable notice to the Contractor, the giving of the date to proceed may be postponed by District. It is further expressly understood by Contractor, that Contractor shall not be entitled to any claim of additional compensation as a result of the postponement of the giving of the notice to proceed

If the Contractor believes that a postponement will cause a hardship to Contractor, Contractor may terminate the Contract with written notice to District within 10 days after receipt by Contractor of District's notice of postponement. It is further understood by Contractor that in the event that Contractor terminates the Contract as a result of postponement by the District, the District shall only be obligated to pay Contractor for the Work that Contractor had performed at the time of notification of postponement and the grounds for notification and hardship shall be subject to Audit pursuant to Article 13.11. Should Contractor terminate the Contract as a result of a notice of postponement, District may award the Contract to the next lowest responsible bidder.

8.1.3 **Computation of Time**

The term "day" as used in the Contract Documents shall mean calendar day unless otherwise specifically defined.

8.1.4 **Float**

Float is time the total number of days an activity may be extended or delayed without delaying the Completion Date shown in the schedule. Float will fall into three categories: (1) Rain Days; (2) Governmental Delays; and, (3) Project Float. Project Float and Rain Days are owned by the Project and may be utilized as necessary for critical path delays once the days become available for consumption (i.e. the Rain Day arrives and is not utilized since rain did not occur or Work was performed on the interior of a building). However, Governmental Delay float shall not be utilized for purposes other than to address critical path delays that arise due to approvals, Inspector approvals or verifications on governmental forms.

GENERAL CONDITIONS

8.1.4.1 *Governmental Delay Float.* It is anticipated that there will be governmental generated delays. Specific to DSA approvals, it is anticipated that no less than twelve (12) days per calendar year shall be set aside as Governmental Float to be utilized on critical path delays. A pro-rated number of days shall be calculated based on length of Contract Time. (For example, a two (2) year Contract Time shall require twenty-four (24) days of Governmental Float. If the Contract Time is 182 days, then the Contract Time shall require six (6) days of Governmental Float) This Governmental Delay float must be incorporated into the schedule and should be incorporated in each critical activity as Contractor deems fit. Specifically, major categories of Work under the DSA 152 (Project Inspection Card) should be allocated Governmental Delay Float at the Contractor's discretion. Governmental Delay Float on the Project may exceed 12 days per one (1) year period, but Contractor is required to include not be less than 12 days of Governmental Delay Float during each one (1) year period.

Contractor's failure to establish a protocol for requesting inspections is not grounds to utilize Governmental Delay Float. As noted in Article ARTICLE 1, 48 hours advance notice of commencing Work on a new area is required after submitting form DSA 156 and under PR 13-01 Special Inspection reports are not required to be posted until at least 14 days after the Work was inspected. Failure to plan, and pay (if applicable) for quicker delivery of Special Inspections is not Governmental Delay Float under Article 8.1.4.1. If Governmental Delay Float is not utilized, this float is carried through to other DSA 152 categories of inspection and consumed over the course of the Project

Governmental Delay Float may be utilized for a DSA Stop Work Order regardless of fault as defined under Education Code section 17307.5(b).

8.1.4.2 *Inclement Weather (Rain Days).* The Contractor will only be allowed a time extension for unusually severe weather if it results in precipitation or other conditions which in the amount, frequency, or duration is in excess of the norm at the location and time of year in question as established by NOAA weather data. No less than 22 calendar days for each calendar year for Southern California will be allotted for in the Contractor's schedule for each winter weather period or carried at the end of the schedule as Rain Float. Float for weather days in other geographical regions shall be adjusted based on NOAA weather data for the geographical location. Contractor has anticipated all the days it takes to dry out and re-prepare areas that may be affected by weather delays which extend beyond the actual weather days. The weather days shall be shown on the schedule and if not used will become float for the Project's use. The Contractor will not be allowed a day-for-day weather delay for periods noted as float in the Schedule. The Contractor is expected to work seven (7) days per week (if necessary, irrespective of inclement weather), to maintain access, and to protect the Work under construction from the effects of inclement weather. Additional days beyond the NOAA shall be considered under the same criteria that weather days are granted below.

A Rain Day shall be granted by Architect or CM if the weather prevents the Contractor from beginning Work at the usual daily starting time, or prevents the Contractor from proceeding with seventy-five (75%) of the normal labor and equipment force towards completion of the day's current controlling item on the accepted schedule for a period of at least five hours, and the crew is dismissed as a result thereof, the Architect will designate such time as unavoidable delay and grant one (1) critical path activity calendar-day extension if there is no available float for the calendar year.

8.1.4.3 *Project Float.* The Contractor may determine some activities require a lesser duration than allocated and may set aside float in the Project Schedule. There shall be no early completion. Instead, to the extent float is either addressed at the end of the Project or throughout each category of critical path work, Project float may be used as necessary during the course of the Project and allocated on a first,

GENERAL CONDITIONS

come first serve basis. However, the use of float does not extend to Governmental Delay Float, which shall only be used for Governmental Delays.

8.2 HOURS OF WORK

8.2.1 Sufficient Forces

Contractors and Subcontractors shall continuously furnish sufficient forces to ensure the prosecution of the Work in accordance with the Construction Schedule.

8.2.2 Performance During Working Hours

Work shall be performed during regular working hours as permitted by the appropriate governmental agency except that in the event of an emergency, or when required to complete the Work in accordance with job progress, Work may be performed outside of regular working hours with the advance written consent of the District and approval of any required governmental agencies.

8.2.3 Costs for After Hours Inspections

If the Work done after hours is required by the Contract Documents, a Recovery Schedule, or as a result of the Contractor's failure to plan, and inspection must be conducted outside the Inspector's regular working hours, the costs of any after hour inspections, shall be borne by the Contractor.

If the District allows the Contractor to do Work outside regular working hours for the Contractor's convenience, the costs of any inspections required outside regular working hours shall be invoiced to the Contractor by the District and a Deductive Change Order shall be issued from the next Progress Payment.

If the Contractor elects to perform Work outside the Inspector's regular working hours, costs of any inspections required outside regular working hours shall be invoiced to the Contractor by the District and a Deductive Change Order from the next Progress Payment as a Deductive Change Order.

8.3 PROGRESS AND COMPLETION

8.3.1 Time of the Essence

Time limits stated in the Contract Documents are of the essence to the Contract. By executing the Agreement, the Contractor confirms that the Contract Time is a reasonable period for performing the Work.

8.3.2 Baseline Schedule Requirements

8.3.2.1 *Timing:* Within ten (10) calendar days after Notice to Proceed, Contractor shall submit a practical schedule showing the order in which the Contractor proposes to perform the Work, and the dates on which the Contractor contemplates starting and completing the salient categories of the Work. This first schedule which outlines the Contractor's view of the practical way in which the Work will be accomplished is the Baseline Schedule. If the Contractor Fails to submit the Baseline Schedule within the ten (10) days noted, then District may withhold processing and approval of progress payments pursuant to Article 9.4 and 9.6.

GENERAL CONDITIONS

8.3.2.2 *District Review and Approval:* District, Architect and CM will review both a paper and electronic copy of Baseline Schedule and may provide comments as noted in this Article and either approve or disapprove the Baseline Schedule. All Schedules shall be prepared using an electronic scheduling program acceptable to District. All Schedules shall be delivered in an electronic format usable by the District. All logic ties and electronic information shall be included in the electronic copy of the Baseline Schedule that is delivered to the District.

8.3.2.3 *Schedule Must Be Within the Given Contract Time.* The Baseline Schedule shall not exceed time limits set forth in the Contract Documents and shall comply with all of the scheduling requirements as set forth in the Specifications and Contract Documents.

8.3.2.4 *Submittals Must Be Incorporated (See Articles ARTICLE 1 and ARTICLE 1):* Contractor shall include Submittals as line items in the Baseline Schedule as required under Article ARTICLE 1 and ARTICLE 1. Submittals shall not delay the Work, Milestones, or the Completion Date. Failure to include Submittals in the Baseline Schedule shall be deemed a material breach by the Contractor.

8.3.2.5 *Float Must Be Incorporated.* The Baseline Schedule must indicate the beginning and completion of all phases of construction and shall use the “critical path method” (commonly called CPM) for the value reporting, planning and scheduling, of all Work required under the Contract Documents. The Baseline Schedule must incorporate all Milestones in the Project and apply Governmental Float at each Milestone in the Contractor’s discretion. The Baseline Schedule shall incorporate any Schedule provided by the District as part of the bid and shall note durations that will not be adequate or should be shortened based on Contractor’s review. These changes shall be identified and incorporated into Contractor’s Baseline Schedule as long as requested changes are made within 10 days after the District chooses to move forward with the Project. Scheduling is necessary for the District’s adequate monitoring of the progress of the Work and shall be prepared in accordance with the time frame described in this Article 8. The Architect may disapprove of any Schedule or require modification to it if, in the opinion of the Architect or District, adherence to the any Schedule prepared by the Contractor will not cause the Work to be completed in accordance with the Agreement.

8.3.2.6 *No Early Completion.* Contractor shall not submit any Schedule showing early completion without indicating float time through the date set for Project completion by District. Contractor’s Baseline Schedule shall account for all days past early completion as float which belongs to the Project. Usage of float shall not entitle Contractor to any delay Claim or damages due to delay.

8.3.2.7 *Use of Schedule Provided in Bid Documents.* In some cases, the bid will include a preliminary schedule indicating Milestones and construction sequences for the Project along with general timing for the Project. The preliminary schedule is not intended to serve as the Baseline Schedule utilized for construction. It is up to the Contractor to study and develop a Baseline Schedule to address the actual durations and sequences of Work that is anticipated while maintaining the Milestones provided by the District. Contract shall obtain information from Contractor’s Subcontractors and vendors on the planning, progress, delivery of equipment, coordination, and timing of availability of Subcontractors so a practical plan of Work is fully developed and represented in the Baseline Schedule.

8.3.2.8 *Incorrect Logic, Durations, Sequences, or Critical Path.* The District may reject or indicate durations, sequences, critical path or logic are not acceptable and request changes. The electronic copy of the Baseline Schedule shall have adequate information so logic ties, duration, sequences and critical path may be reviewed electronically. Contractor is to diligently rebuild and resubmit the Baseline Schedule to represent the Contractor’s plan to complete the Work and maintain Milestones at the next progress meeting, or before the next progress meeting. If Contractor is not able to build a Baseline

GENERAL CONDITIONS

Schedule that is acceptable to the District or Architect, the District reserves the right to utilize the unapproved originally submitted Baseline Schedule (See Article 8.3.2.12) and the comments submitted to hold Contractor accountable for timely delivery of Work and maintenance of Milestones. Furthermore, Contractor's representations in the Baseline Schedule, if unacceptable, may also be used as a basis for termination of the Contract under Article 14 if Contractor fails to adequately maintain the Schedule and falls significantly behind without undertaking the efforts to either submit and follow a Recovery Schedule or fail to submit a Recovery Schedule and make no effort toward recovery on the Project.

8.3.2.9 *Contractor Responsibility Even if Schedule Issues Are Not Discovered.* Failure on the Part of the District to discover errors or omissions in any Schedules submitted shall not be construed to be an approval of the error or omission and any flawed Schedule is not grounds for a time extension.

8.3.2.9 Inclusions in Baseline Schedule. In addition to scheduling requirements set forth at Article 8.3.2, Contractor is specifically directed to include (broken out separately) in Contractor's Baseline Schedule and all Schedule updates, the following items required pursuant to these General Conditions, including but not limited to:

1. Rain Day Float (excluding inclement weather) as required under Article 8.1.4.2. For example, if the NOAA provides 22 days of Rain Days, all 22 days must be incorporated and noted in the Baseline Schedule. Further, any days required to clean-up or dry out shall be included for operations that are likely to require a clean-up or dry out period. Days that are not utilized shall be considered float owned by the Project.
2. Governmental Delay Float under Article 8.1.4.1. This Governmental Delay Float shall only be utilized for Governmental Delays and shall not be considered available float owned by the Project. This float shall only be distributed to the Project upon the completion of the Project and shall be used to offset Liquidated Damages and shall not generate compensable delays.
3. Submittal and Shop Drawing schedule under Article ARTICLE 1.
4. Deferred Approvals under Article ARTICLE 1.
5. Time for separate contractors, including furniture installation and start up activities, under Article 6.1.
6. Coordination and timing of any Drawings, approvals, notifications, permitting, connection, and testing for all utilities for the Project. (See Article 2.1.4).
7. Testing, special events, or school activities

8.3.2.10 *Failure to include Mandatory Schedule Items.* District may withhold payment pursuant to Articles 9.3, 9.4 and 9.6. In lieu of withholding payment for failure to include Mandatory Schedule Items, after the District or Architect has notified the Contractor of failure to meet the Baseline Schedule or Updated Schedule requirements and provided a written notification of this failure and provided a written notice of Schedule preparation errors, and the Contractor fails to correct the noted deficiencies or

GENERAL CONDITIONS

the Contractor does not provide an updated Baseline Schedule correcting the deficiencies, then Contractor shall not be granted an extension of time for failure to obtain necessary items and approvals under Article 8.3.2 and for the time required for failure to comply with laws, building codes, and other regulations (including Title 24 of the California Code of Regulations). Contractor shall maintain all required Article 8.3.2 Schedule items in the Baseline Schedule and indicate any days that have been used as allowed in Article 8. If Contractor fails to include all Article 8.3.2 items in its Baseline Schedule or Schedule Updates and the District either utilizes an Unapproved Schedule under Article 8.3.2.12 or does not object to the inclusion of required scheduling items, then all mandatory Schedule inclusions, including float, shall be utilized in the District's discretion. If the Contract Time is exceeded, then Contractor shall be subject to the assessment of Liquidated Damages pursuant to Article 8.4.

8.3.2.11 *Failure to Meet Requirements.* Failure of the Contractor to provide proper Schedules as required by this Article and Article 9 is a material breach of the Contract and grounds for Termination pursuant to Article 14. The District, at its sole discretion, may choose, instead, to withhold, in whole or in part, any Progress Payments or Retention amounts otherwise payable to the Contractor.

8.3.2.12 *Use of an Unapproved Baseline Schedule.* If the Baseline Schedule submitted by the Contractor is unacceptable to the District (i.e. failing to meet the requirements of Article 8.3.2) and Contractor does not incorporate or address the written comments to the Baseline Schedule and a Baseline Schedule is not approved, but due to extreme necessity, the District moves forward without an approved Baseline Schedule, Contractor shall diligently revise and meet Schedule update requirements of Article 8 and incorporate all Article 8.3.2 comments in all updates). However, for purposes of Termination pursuant to Article 14, the unapproved Baseline Schedule initially submitted shall be treated as the Baseline Schedule with durations shortened or revised to accommodate all float, all mandatory Schedule requirements under Article 8.3.2, any requirements in the Contract Documents, and all revisions by the District or Architect.

8.3.3 Update Schedules

8.3.3.1 *Updates Shall Be Based on Approved Baseline Schedule.* Except in the case where there has not been agreement as to a Baseline Schedule, the approved Baseline Schedule shall be used to build future Schedule updates. Schedule updates shall be a CPM based Schedule consistent with the Baseline Schedule requirements of 8.3.2

In the case that no Baseline has been approved, Schedule updates shall be provided monthly and each update shall incorporate all comments and revisions noted as not complying with the requirements of Article 8.3.2. Contractor shall be held to the Article 8.3.2.12 unapproved Baseline Schedule, inclusive of all Milestones, float, comments and revisions by the District and Architect, all required Baseline Schedule Inclusions under Article 8.3.2, and any requirements in the Contract Documents.

8.3.3.2 *Schedule Updates.* Contractor shall update the approved Schedule each month to address actual start dates and durations, the percent complete on activities, actual completion dates, estimated remaining duration for the Work in progress, estimated start dates for Work scheduled to start at future times and changes in duration of Work items

8.3.3.3 *Listing of Items Causing Delays.* Schedule updates shall provide a listing of activities which are causing delay in the progress of Work and a narrative shall be provided showing a description of problem areas, anticipated delays, and impacts on the Construction Schedule. Simply stating "District Delay" or "Architect Delay" shall be an inadequate listing. Delays shall only be listed if they meet the requirements of Article 8.4.

GENERAL CONDITIONS

8.3.3.4 *Recovery Schedule*. In addition to providing a schedule update every thirty (30) days, the Contractor, if requested by the Architect or District, shall take the steps necessary to improve Contractor's progress and demonstrate to the District and Architect that the Contractor has seriously considered how the lost time, the Completion Date, or the Milestones that are required to be met within the terms of the Contract. Contractor shall immediately provide a Recovery Schedule showing how Milestones and the Completion Date will be met. In no case, shall a Recovery Schedule be provided later than ten (10) days following the request for a Recovery Schedule from the Architect or District.

- a. Failure to Provide a Recovery Schedule. Shall subject Contractor to the assessment of Liquidated Damages for failure to meet the Contract Time. Refusal or failure to provide a Recovery Schedule shall be considered a substantial failure of performance and a material breach of Contract and may result in Termination of the Contract pursuant to Article 14.
- b. Recovery Schedule Acceleration without Additional Cost. The District may require Contractor prepare a Recovery Schedule showing how the Project shall be accelerated, without any additional cost to the District. The District may order, without additional cost, the following:
 1. Increase the number of shifts;
 2. Utilize overtime to recover the approved Schedule; and/or
 3. Increase the days when Work occurs, including weekends, at the Project and at any manufacturer's plant.
- c. Recovery Schedule Acceleration without Additional Cost. If Contractor disputes that the Recovery Schedule acceleration shall be issued without additional costs, the Contractor shall submit concurrent with Recovery Schedule acceleration notice pursuant to Articles 8.4.3 and 8.4.4.

8.4 **EXTENSIONS OF TIME - LIQUIDATED DAMAGES**

8.4.1 Liquidated Damages

CONTRACTOR AND DISTRICT HEREBY AGREE THAT THE EXACT AMOUNT OF DAMAGES FOR FAILURE TO COMPLETE THE WORK WITHIN THE TIME SPECIFIED IS EXTREMELY DIFFICULT OR IMPOSSIBLE TO DETERMINE. IF THE WORK IS NOT SUBSTANTIALLY COMPLETED IN THE TIME SET FORTH IN THE AGREEMENT, IT IS UNDERSTOOD THAT THE DISTRICT WILL SUFFER DAMAGES. IT BEING IMPRACTICAL AND UNFEASIBLE TO DETERMINE THE AMOUNT OF ACTUAL DAMAGE, IT IS AGREED THE CONTRACTOR SHALL PAY TO THE DISTRICT THE AMOUNT LIQUIDATED DAMAGES SET FORTH IN THE AGREEMENT, FOR EACH CALENDAR DAY OF DELAY IN REACHING SUBSTANTIAL COMPLETION (SEE ARTICLE 1.1.46). CONTRACTOR AND ITS SURETY SHALL BE LIABLE FOR THE AMOUNT THEREOF PURSUANT TO GOVERNMENT CODE SECTION 53069.85.

8.4.2 Delay

GENERAL CONDITIONS

Except and only to the extent provided under Article 7 and Article 8, by signing the Agreement, Contractor agrees to bear the risk of delays to Completion of the Work and that Contractor's bid for the Project was made with full knowledge of this risk.

In agreeing to bear the risk of delays to complete the Work, Contractor understands that, except and only to the extent provided otherwise in Article 7 and 8, the occurrence of events that delay the Work shall not excuse Contractor from its obligation to achieve Completion of the Project within the Contract Time, and shall not entitle the Contractor to an adjustment to the Contract time.

8.4.3 Excusable Delay

Contractor shall not be charged for Liquidated Damages because of any delays in completion of Work which are not the fault or negligence of Contractor or its Subcontractors, arising from Rain Float or Project Float, including acts of God, as defined in Public Contract Code section 7105, acts of enemy, epidemics and quarantine restrictions. Contractor shall within five (5) calendar days of beginning of any such delay notify District in writing of causes of delay; thereupon District shall ascertain the facts and extent of delay and grant extension of time for completing Work when, in its judgment, the findings of fact justify such an extension. Extensions of time shall apply only to that portion of Work affected by delay, and shall not apply to other portions of Work not so affected. An extension of time may only be granted after proper compliance with Article 8.3 requiring preparation and submission of a properly prepared CPM schedule.

8.4.3.1 *Excusable Delay Is Not Compensable.* No extended overhead, general conditions costs, impact costs, out-of-sequence costs or any other type of compensation, by any name or characterization, shall be paid to the Contractor for any delay to any activity not designated as a critical path item on the latest approved Project schedule.

8.4.3.2 *Notification.* The Contractor shall notify the Architect in writing of any anticipated delay and its cause, in order that the Architect may take immediate steps to prevent, if possible, the occurrence or continuance of delay, and may determine whether the delay is to be considered avoidable or unavoidable, how long it continues, and to what extent the prosecution and completion of the Work might be delayed thereby.

8.4.3.3 *Extension Request.* In the event the Contractor requests an extension of Contract time for unavoidable delay, such request shall be submitted in accordance with the provisions in the Contract Documents governing changes in Work (See Article 7). When requesting time, i.e., extensions, for proposed Change Orders, they must be submitted with the proposed Change Order with full justification and documentation. If the Contractor fails to submit justification with the proposed Change Order it waives its right to a time extension at a later date. Such justification must be based on the official Contract schedule as updated at the time of occurrence of the delay or execution of Work related to any changes to the scope of Work. Blanket or general claims for extra days without specific detailed information as required herein or a blanket or general reservation of rights do not fulfill the requirements of this Article and shall be denied. The justification must include, but is not limited to, the following information:

- a. The duration of the activity relating to the changes in the Work and the resources (manpower, equipment, material, etc.) required to perform these activities within the stated duration.
- b. Logical ties to the official Baseline Schedule or Approved Updated Schedule for the proposed changes and/or delay showing the activity/activities in the schedule

GENERAL CONDITIONS

whose start or completion dates are affected by the change and/or delay. (A fragnet of any delay of over ten (10) days must be provided.)

The Contractor and District understand and expressly agree that insofar as Public Contract Code section 7102 may apply to changes in the Work or delays under this Contract, the actual delays and damages, if any, and time extensions are intended to, and shall provide, the exclusive and full method of compensation for changes in the Work and construction delays.

8.4.4 Notice by Contractor Required

The Contractor shall within five (5) calendar days of beginning of any such delay notify the District in writing of causes of delay with justification and supporting documentation. In the case of a Recovery Schedule pursuant to Article 8.3.3.4, Contractor shall submit written notice concurrent with the Recovery Schedule. District will then ascertain the facts and extent of the delay and grant an extension of time for completing the Work when, in its judgment, the findings of fact justify such an extension. Extensions of time shall apply only to that portion of the Work affected by the delay and shall not apply to other portions of the Work not so affected.

Claims relating to time extensions shall be made in accordance with applicable provisions of Article 7.

8.4.4.1 *Adjustment for Compensable Delays.* The Schedule may be adjusted for a delay if, and only if, Contractor undertakes the following:

- a. Contractor submits a timely COR or CO pursuant to the requirements of Article 7.
- b. Contractor submits a fragnet showing the critical path delay caused by the COR, CO, Changed Condition, CCD, or WD
- c. Contractor has addressed all required float days in the Fragnet.
- d. Contractor submits a complete breakdown of all costs incurred utilizing the format of Article 7.3.3

8.4.5 No Additional Compensation for Coordinating Governmental Submittals and the Resulting Work

CONTRACTOR HAS PLANNED ITS WORK AHEAD OF TIME AND IS AWARE THAT GOVERNMENTAL AGENCIES, SUCH AS THE GAS COMPANIES, ELECTRICAL UTILITY COMPANIES, WATER DISTRICTS AND OTHER AGENCIES MAY HAVE TO APPROVE CONTRACTOR PREPARED DRAWINGS OR APPROVE A PROPOSED INSTALLATION. CONTRACTOR HAS INCLUDED DELAYS AND DAMAGES WHICH MAY BE CAUSED BY SUCH AGENCIES IN CONTRACTOR'S BID AND HAS INCLUDED ADEQUATE TIME IN THE CONTRACTOR'S BASELINE SCHEDULE. FAILURE TO ADEQUATELY PLAN AND SCHEDULE IS NOT A BASIS TO USE GOVERNMENTAL DELAY FLOAT.

8.4.6 District Right to Accelerate the Work

GENERAL CONDITIONS

The District may direct the Contractor to meet schedule requirements when the Work has been delayed. The District shall compensate the Contractor for the additional costs incurred by acceleration to the extent that such costs are directly attributable to the acceleration and are incurred through no fault or negligence of the Contractor.

8.4.6.1 *Management of Acceleration.* Contractor acceleration shall not include Work that is part of the scope of Work detailed in the Plans and Specifications. Instead, the acceleration costs shall be premium or overtime and quantifiable additional work added to the Project meant to accelerate the Project. Contractor is directed to keep consistent crews on the Project so time can be tracked. If crews are circulated off the Project or crews brought in only for overtime, the District may be charged for Contract Work and not accelerated time. In such case, the District may object to the costs submitted.

8.4.6.2 *Costs for Acceleration.* Cost for Acceleration shall be supported by backup documentation, and time sheets signed by the Inspector for each day work has been performed, at or near the time when the Work was performed. A listing on the time sheet shall document all labor, materials and services utilized that day and provide areas of work, and amount of work performed. Contractor shall comply with submission requirements of Article 7.7.

GENERAL CONDITIONS

ARTICLE 9 PAYMENTS AND COMPLETION

9.1 CONTRACT SUM

The Contract Sum or Contract Price is stated in the Agreement and, including authorized adjustments, is the total amount payable by the District to the Contractor for performance of the Work under the Contract Documents.

9.2 COST BREAKDOWN

9.2.1 Required Information

Contractor shall furnish the following:

- a. Within ten (10) days after Notice to Proceed, a detailed breakdown of the Contract Price (hereinafter "Schedule of Values") for each Project, Site, building, Milestone or other meaningful method to measure the level of Project Completion as determined by the District shall be submitted as a Submittal for the Project.;
- b. Within ten (10) days after the date of the Notice to Proceed, a schedule of estimated monthly payment requests due the Contractor showing the values and construction time of the various portions of the Work to be performed by it and by its Subcontractors or material and equipment suppliers containing such supporting evidence as to its correctness as the District may require;
- c. Within ten (10) days after the date of the Notice to Proceed, address, telephone number, telecopier number, California State Contractors License number, classification and monetary value of all subcontracts for parties furnishing labor, material, or equipment for completion of the Project.

9.2.2 Information and Preparation of Schedule of Values

9.2.2.1 *Break Down of Schedule of Values.* Schedule of Values shall be broken down by Project, site, building, Milestone, or other meaningful method to measure the level of Project Completion as determined by the District.

9.2.2.2 *Based on Contractor Bid Costs.* The Schedule of Values shall be based on the costs from Contractor's bid to the District. However, the submission of the Schedule of Values shall not be front loaded so the Contractor is paid a greater value than the value of the Work actually performed and shall not shift funds from parts of the Project that are later to Work that is performed earlier.

9.2.2.3 Largest Dollar Value for Each Line Item. Identify Subcontractors and materials suppliers proposed to provide portions of Work equal to or greater than ten thousand dollars (\$10,000) or one-half of one percent (0.5%) of their Contract Price, whichever is less.

9.2.2.4 *Allowances.* Any Allowances provided for in the Contract shall be a line item in the Schedule of Values.

GENERAL CONDITIONS

9.2.2.5 *Labor and Materials Shall Be Separate.* Labor and Materials shall be broken into two separate line items unless specifically agreed in writing by the District.

9.2.3 District Approval Required

The District shall review all submissions received pursuant to Article 9.2 in a timely manner. All submissions must be approved by the District before becoming the basis of any payment.

9.3 **PROGRESS PAYMENTS**

9.3.1 Payments to Contractor

Unless there is a resolution indicating that the Work for the Project is substantially complex, within thirty-five (35) days after approval of the Request for Payment, Contractor shall be paid a sum equal to ninety-five percent (95%) of the value of the Work performed (as certified by Architect and Inspector and verified by Contractor) up to the last day of the previous month, less the aggregate of previous payments. In the case of a Project designated substantially complex, the sum paid to the Contractor shall be equal to ninety percent (90%) of the value of the Work performed (as certified by the Architect and Inspector and verified by Contractor). The value of the Work completed shall be the Contractor's best estimate. Work completed as estimated shall be an approximation or estimate only and no mistake, inaccuracy, error or falsification in said any approved estimate shall operate to release the Contractor, or any Surety upon any bond, from damages arising from such Work, or from the District's enforcement of each and every provision of this Contract including but not limited to the Performance Bond and Payment Bond. The District shall have the right to subsequently to correct any mistake, inaccuracy, error or falsification made or otherwise set forth in any approved Request for Payment and such correction may occur in any future Payment Application or in the Retention Payment to the Contractor. No Surety upon any bond shall be relieved, released or exonerated of its obligations under this Contract or any applicable bond when the District is unable to correct an overpayment to the Contractor due to any abandonment by the Contractor or termination by the District.

The Contractor shall not be entitled to have any payment requests processed, or be entitled to have any payment made for Work performed, so long as any lawful or proper direction given by the District concerning the Work, or any portion thereof, remains incomplete.

Notwithstanding anything to the contrary stated above, the Contractor may include in its Request for Payment the value of any structural steel, glue laminated beams, trusses, bleachers and other such custom-made materials prepared specifically for the Project and unique to the Project so long as all of the following requirements are satisfied:

- a. The aggregate cost of materials stored off-site shall not exceed Twenty Five Thousand Dollars (\$25,000) at any time or as otherwise agreed to be District in writing;
- b. Title to such materials shall be vested in the District as evidenced by documentation satisfactory in form and substance to the District, including, without limitation, recorded financing statements, UCC filings and UCC searches;
- c. With each Contractor Request for Payment, the Contractor shall submit to the District a written list identifying each location where materials are stored off-site (which must be a bonded warehouse) and the value of the materials at each

GENERAL CONDITIONS

location. The Contractor shall procure insurance satisfactory to the District (in its reasonable discretion) for materials stored off-site in an amount not less than the total value thereof;

- d. The consent of any Surety shall be obtained to the extent required prior to payment for any materials stored off-site;
- e. Representatives of the District shall have the right to make inspections of the storage areas at any time; and
- f. Such materials shall be: (1) protected from diversion, destruction, theft and damage to the reasonable satisfaction of the District; (2) specifically marked for use on the Project; and (3) segregated from other materials at the storage facility.

9.3.2 Purchase of Materials and Equipment and Cost Fluctuations

The Contractor is required to order, obtain, and store materials and equipment sufficiently in advance of its Work at no additional cost or advance payment from District to assure that there will be no delays. Contractor understands that materials fluctuate in value and shall have adequately addressed market fluctuations through agreements with Contractor vendors or by other means. Contractor further understands and incorporates into Contractor's bid cost any wage rate increases during the Project for the Contractor's labor force as well as all other Subcontractor and vendor labor forces. District shall not be responsible for market fluctuations in costs or labor rate increases during the Project. Contractor further has incorporated any and all cost increases in areas of Work where there may be schedule variations so that cost increases are not passed through to the District.

9.3.3 No Waiver

No payment by District hereunder shall be interpreted so as to imply that District has inspected, approved, or accepted any part of the Work. Contractor specifically understands that Title 24 Section 4-343 which states:

“It is the duty of the contractor to complete the work covered by his or her contract in accordance with the approved Plans and Specifications therefore. The contractor in no way is relieved of any responsibility by the activities of the Architect, Engineer, Inspector or DSA in the performance of such duties... In no case, however, shall the instruction of the Architect or registered Engineer be construed to cause work to be done with is not in conformity with the approved Plans, Specifications, and change orders...”

Notwithstanding any payment, the District may enforce each and every provision of this Contract which includes, but is not limited to, the Performance Bond and Payment Bond. The District may correct any error subsequent to any payment. In no event shall the Contractor or the Surety be released or exonerated from performance under this Contract when the District overpays the Contractor based upon any mistake, inaccuracy, error or falsification in any estimate that is included in any Request for Payment.

9.3.4 Issuance of Certificate of Payment

The Architect shall, within seven (7) days after receipt of the Contractor's Application for Payment, either approve such payment or notify the Contractor in writing of the Architect's reasons for

GENERAL CONDITIONS

withholding approval in whole or in part as provided in Article 9.6. The review of the Contractor's Application for Payment by the Architect is based on the Architect's observations at the Project and the data comprising the Application for Payment that the Work has progressed to the point indicated and that, to the best of the Architect's knowledge, information, and belief, the quality of the Work is in accordance with the Contract Documents. In some cases, the Architect may act upon or rely on the evaluation of the Work by the Inspector. This review of Payment Applications is sometimes called a "Pencil Draft." District's return of a Pencil Draft shall constitute the District's dispute of the Payment Application that has been submitted. Contractor shall promptly respond to Pencil Drafts or Contractor's Payment Applications may be delayed. Contractor's failure to promptly respond to a Pencil Draft shall qualify as a delay in the prompt payment of a Request for Payment or Request for Retention. The foregoing representations are subject to: (1) an evaluation of the Work for conformance with the Contract Documents, (2) results of subsequent tests and inspections, (3) minor deviations from the Contract Documents correctable prior to completion, and (4) specific qualifications expressed by the Architect. The issuance of a Certificate for Payment will further constitute the Contractor's verified representation that the Contractor is entitled to payment in the amount certified.

9.3.5 Payment of Undisputed Contract Payments

In accordance with Public Contract Code section 7100, payments by the District to the Contractor for any and all undisputed amounts (including all Progress Payments, Final Payments or Retention Payment) is contingent upon submission of a proper and accurate Payment Application and the Contractor furnishing the District with a release of all Claims against the District related to such undisputed amounts. Disputed Contract Claims in stated amounts may be specifically excluded by the Contractor from the operation of the release. If, however, the Contractor specifically excludes any Claims, the Contractor shall provide details such as a specific number of disputed days or costs of any such exclusion in accordance with Articles 4.6 and 7.7.

9.4 APPLICATIONS FOR PROGRESS PAYMENTS

9.4.1 Procedure

9.4.1.1 *Application for Progress.* On or before the fifth (5th) day of each calendar month during the progress of the Work, Contractor shall submit to the Architect an itemized Application for Progress Payment for operations completed. Such application shall be notarized, if required, and supported by the following or such portion thereof as Architect requires:

1. The amount paid to the date of the Payment Application to the Contractor, to all its Subcontractors, and all others furnishing labor, material, or equipment for its Contract;
2. The amount being requested under the Payment Application by the Contractor on its own behalf and separately stating the amount requested on behalf of each of the Subcontractors and all others furnishing labor, material, and equipment under the Contract;
3. The balance that will be due to each of such entities after said payment is made;
4. A certification that the As-Built Drawings and Annotated Specifications are current;

GENERAL CONDITIONS

5. Itemized breakdown of Work done for the purpose of requesting partial payment;
6. An updated or approved Baseline Schedule or other Schedule updates in conformance with Article 8;
7. Failure to submit an updated Schedule for the month or any previous month;
8. The additions to and subtractions from the Contract Price and Contract Time;
9. A summary of the Retention held;
10. Material invoices, evidence of equipment purchases, rentals, and other support and details of cost as the District may require from time to time;
11. The percentage of completion of the Contractor's Work by line item;
12. An updated Schedule of Values from the preceding Application for Payment;
13. Prerequisites for Progress Payments; and
14. Any other information or documents reasonably requested by the District, Architect, Inspector or CM (if applicable).

9.4.1.2 *First Payment Request.* The following items, if applicable, must be completed before the first payment request will be accepted for processing:

1. Installation of the Project sign;
2. Receipt by Architect of Submittals;
3. Installation of field office;
4. Installation of temporary facilities and fencing;
5. Submission of documents listed in the Article 9.2 relating to Contract Price breakdown;
6. Preliminary schedule analysis, due within 10 days after Notice to Proceed;
7. Contractor's Baseline Schedule (to be CPM based in conformance with Article 8);
8. Schedule of unit prices, if applicable;
9. Submittal Schedule;
10. Copies of necessary permits;

GENERAL CONDITIONS

11. Copies of authorizations and licenses from governing authorities;
12. Initial progress report;
13. Surveyor qualifications;
14. Written acceptance of District's survey of rough grading, if applicable;
15. List of all Subcontractors, with names, license numbers, telephone numbers, and scope of work;
16. All bonds and insurance endorsements; and
17. Resumes of General Contractor's Project Manager, and if applicable, job site secretary, record documents recorder, and job site Superintendent.

9.4.1.3 *Second Payment Request.* The second payment request will not be processed until all Submittals and Shop Drawings have been accepted for review by the Architect.

9.4.1.4 *All Payment Requests.* No payment requests will be processed unless Contractor has submitted copies of the certified payroll records for the Work which correlates to the payment request and a proper CPM schedule pursuant to Article 8 is submitted.

9.4.1.5 *Final Payment Application (90% or 95%).* See Article 9.11.1

9.4.1.6 *Final Payment Application (100%).* See Article 9.11.3

9.5 **STOP NOTICE CLAIMS AND WARRANTY OF TITLE**

The Contractor warrants title to all Work. The Contractor further warrants that all Work is free and clear of liens, claims, security interests, stop notices, or encumbrances in favor of the Contractor, Subcontractors, material and equipment suppliers, or other persons or entities making a claim by reason of having provided labor, materials, and equipment relating to the Work. Failure to keep work free of liens, stop notices, claims, security interests or encumbrances is grounds to make a claim against Contractor's Payment and Performance Bond to immediately remedy and defend.

If a lien or stop notice of any nature should at any time be filed against the Work or any District property, by any entity which has supplied material or services at the request of the Contractor, Contractor and Contractor's Surety shall promptly, on demand by District and at Contractor's and Surety's own expense, take any and all action necessary to cause any such lien or stop notice to be released or discharged immediately therefrom.

If the Contractor fails to furnish to the District within ten (10) calendar days after written demand by the District, satisfactory evidence that a lien or stop notice has been so released, discharged, or secured, then District may discharge such indebtedness and deduct the amount required therefor, together with any and all losses, costs, damages, and attorney's fees and expense incurred or suffered by District from any sum payable to Contractor under the Contract. In addition, any liens, stop notices, claims, security interests or encumbrances shall trigger the indemnification requirements under Article ARTICLE 1 and the Agreement Form, and shall act as a trigger under Civil Code section 2778 and 2779 requiring reimbursement for any and all costs following the District's written demand has been made. Any

GENERAL CONDITIONS

withholdings by the District for stop notices in accordance with Civil Code section 9358 shall not be a basis by the Contractor to make a Claim for interest penalties under Public Contract Code sections 7107 or 20104.50.

9.6 DECISIONS TO WITHHOLD PAYMENT

9.6.1 Reasons to Withhold Payment

The District may withhold payment in whole, or in part, to the extent reasonably necessary to protect the District if, in the District's opinion, the representations to the District required by Article 9.4 cannot be made. The District may withhold payment, in whole, or in part, to such extent as may be necessary to protect the District from loss because of, but not limited to:

- a. Defective Work not remedied;
- b. Stop notices served upon the District;
- c. Liquidated Damages assessed against the Contractor;
- d. The cost of Completion of the Contract if there exists reasonable doubt that the Work can be Completed for the unpaid balance of any Contract Price or by the completion date;
- e. Damage to the District or other contractor;
- f. Unsatisfactory prosecution of the Work by the Contractor;
- g. Failure to store and properly secure materials;
- h. Failure of the Contractor to submit on a timely basis, proper and sufficient documentation required by the Contract Documents, including, without limitation, acceptable monthly progress schedules, Shop Drawings, Submittal schedules, Schedule of Values, Product Data and samples, proposed product lists, executed Change Order, Construction Change Documents, and verified reports;
- i. Failure of the Contractor to maintain As-Built Drawings;
- j. Erroneous estimates by the Contractor of the value of the Work performed, or other false statements in an Payment Application;
- k. Unauthorized deviations from the Contract Documents (including but not limited to Unresolved Notices of Deviations (DSA Form 154));
- l. Failure of the Contractor to prosecute the Work in a timely manner in compliance with established progress schedules and completion dates.
- m. Failure to properly pay prevailing wages as defined in Labor Code section 1720, et seq.;
- n. Failure to properly maintain or clean up the Site;

GENERAL CONDITIONS

- o. Payments to indemnify, defend, or hold harmless the District;
- p. Any payments due to the District including but not limited to payments for failed tests, or utilities changes or permits;
- q. Failure to submit an acceptable Baseline Schedule or any Schedule or Schedule update in accordance with Article 8;
- r. Failure to pay Subcontractor or suppliers as required by Article 9.8.1
- s. Failure to secure warranties, including the cost to pay for warranties;
- t. Failure to provide releases from material suppliers or Subcontractors when requested to do so;
- u. Items deducted pursuant to Article 2.2;
- v. Incomplete Punch List items under Article 9.9.1.1 which have gone through the Article 2.2 process; or
- w. Allowances that have not been used.

9.6.2 **Reallocation of Withheld Amounts**

District may, in its discretion, apply any withheld amount to payment of outstanding claims or obligations as defined in Article 9.6.1 and 9.5. In so doing, District shall make such payments on behalf of Contractor. If any payment is so made by District, then such amount shall be considered as a payment made under Contract by District to Contractor and District shall not be liable to Contractor for such payments made in good faith. Such payments may be made without prior judicial determination of claim or obligation. District will render Contractor an accounting of such funds disbursed on behalf of Contractor.

If Contractor defaults or neglects to carry out the Work in accordance with the Contract Documents or fails to perform any provision thereof, District may, after ten (10) calendar days written notice to the Contractor and without prejudice to any other remedy make good such deficiencies. The District shall adjust the total Contract price by reducing the amount thereof by the cost of making good such deficiencies. If District deems it inexpedient to correct Work which is damaged, defective, or not done in accordance with Contract provisions, an equitable reduction in the Contract Price (of at least 150% of the estimated reasonable value of the nonconforming Work) shall be made therefor.

9.6.3 **Payment After Cure**

When the grounds for declining approval are removed, payment shall be made for amounts withheld because of them. No interest shall be paid on any retainage or amounts withheld due to the failure of the Contractor to perform in accordance with the terms and conditions of the Contract Documents.

9.7 **NONCONFORMING WORK**

Contractor shall promptly remove from premises all Work identified by District as failing to conform to the Contract whether incorporated or not. Contractor shall promptly replace and re-execute its

GENERAL CONDITIONS

own Work to comply with the Contract without additional expense to District and shall bear the expense of making good all Work of other contractors destroyed or damaged by such removal or replacement.

If Contractor does not remove such Work which has been identified by District as failing to conform to the Contract Documents within a reasonable time, fixed by written notice, District may remove it and may store the material at Contractor's expense. If Contractor does not pay expenses of such removal within ten (10) calendar days' time thereafter, District may, upon ten (10) calendar days' written notice, sell such materials at auction or at private sale and shall account for net proceeds thereof, after deducting all costs and expenses that should have been borne by Contractor.

9.8 SUBCONTRACTOR PAYMENTS

9.8.1 Payments to Subcontractors

No later than ten (10) days after receipt, or pursuant to Business and Professions Code section 7108.5, the Contractor shall pay to each Subcontractor, out of the amount paid to the Contractor on account of such Subcontractor's portion of the Work, the amount to which said Subcontractor is entitled. The Contractor shall, by appropriate agreement with each Subcontractor, require each Subcontractor to make payments to Sub-subcontractors in a similar manner.

9.8.2 No Obligation of District for Subcontractor Payment

The District shall have no obligation to pay, or to see to the payment of, money to a Subcontractor except as may otherwise be required by law.

9.8.3 Payment Not Constituting Approval or Acceptance

An approved Request for Payment, a progress payment, a Certificate of Substantial Completion, or partial or entire use or occupancy of the Project by the District shall not constitute acceptance of Work that is not in accordance with the Contract Documents.

9.8.4 Joint Checks

District shall have the right, if necessary for the protection of the District, to issue joint checks made payable to the Contractor and Subcontractors and material or equipment suppliers. The joint check payees shall be responsible for the allocation and disbursement of funds included as part of any such joint payment. In no event shall any joint check payment be construed to create any contract between the District and a Subcontractor of any tier, any obligation from the District to such Subcontractor, or rights in such Subcontractor against the District. The District may choose to issue joint checks at District's sole discretion and only after all the requirements of that particular school district and county are specifically met. Some school districts cannot issue joint checks, so the ability to issue joint checks depends on the school district and the specific circumstances.

9.9 COMPLETION OF THE WORK

9.9.1 Close-Out Procedures

9.9.1.1 *Incomplete Punch Items.* When the Contractor considers the Work Substantially Complete (See Article 1.1.46 for definition of Substantially Complete), the Contractor shall prepare and submit to the District a comprehensive list of minor items to be completed or corrected

GENERAL CONDITIONS

(hereinafter “Incomplete Punch Items” or “Punch List”). The Contractor and/or its Subcontractors shall proceed promptly to complete and correct the Incomplete Punch Items listed. Failure to include an item on such list does not alter the responsibility of the Contractor to complete all Work in accordance with the Contract Documents. Contractor is aware that Title 24 Section 4-343(a) provides:

“RESPONSIBILITIES. IT IS THE DUTY OF THE CONTRACTOR TO COMPLETE THE WORK COVERED BY HIS OR HER CONTRACT IN ACCORDANCE WITH THE APPROVED PLANS AND SPECIFICATIONS THEREFOR. THE CONTRACTOR IN NO WAY IS RELIEVED OF ANY RESPONSIBILITY BY THE ACTIVITIES OF THE ARCHITECT, ENGINEER, INSPECTOR OR DSA IN THE PERFORMANCE OF SUCH DUTIES.

9.9.1.2 *Punch List Is Prepared Only After the Project Is Substantially Complete.* If any of the conditions noted in Article 1.1.46 as defining Substantial Completion are not met, the Inspector, Architect or District may reject Contractor’s Incomplete Punch Items as premature. If the Architect and Inspector commence review of Incomplete Punch Items, all rights are reserved until the Project actually meets the definition of Substantially Complete. Liquidated Damages, warranties, and other contractual rights are not affected by Incomplete Punch Items unless otherwise addressed in these General Conditions.

Once the Inspector and the Architect determine the Project is Substantially Complete, a Certificate of Substantial Completion shall be issued. The Inspector and Architect shall prepare a Punch List of items which is an inspection report of the Work, if any, required in order to complete the Contract Documents and ensure compliance with the DSA Approved Plans so the Project may be Completed by the Contractor and a final DSA Close-Out is approved. When all Work for the Project is Complete, including Punch Lists and all Work complies with the approved Contract Documents and Change Orders, the Project has reached Final Completion.

9.9.1.3 *Time for Completion of Punch List.* Contractor shall only be given a period of no more than thirty (30) days to complete the Punch List for the Project. During the Punch List period, the Contractor’s Superintendent and Project Manager shall remain engaged in the Project and shall not be removed or replaced. If the Punch List is not completed at the end of the Punch List time then Contractor shall issue a valued Punch List within 5 days after the date the Punch List time ends. If Contractor does not issue such a list, the District or Architect may issue a valued Punch List to the Contractor and withhold up to 150% of the value of the Punch List Work pursuant to Article 2.2 of this Agreement.

Failure to issue a timely written request for additional time to complete Punch List shall result in the deletion of the remaining Punch List Work pursuant to Article 2.2 and the issuance of a Deductive Change Order.

- a. Extension of Time to Complete Punch List. If Contractor cannot finish the Punch List Work during the time period allotted under Article 9.9.1.3, the Contractor may make a written request for a Non-Compensable Punch List time extension accompanied by an estimate of the number of additional days it will take to complete the Punch List Work for a written consent from the District to allow continued Punch List Work. Punch List time extensions are a maximum of thirty (30) days for each request and must be accompanied by an itemized valued Punch List.
- b. If there is no valued Punch List accompanying any request or if Contractor intends to undertake Punch List without the continued support and

GENERAL CONDITIONS

supervision of its Superintendent and Project Manager (as required under Article ARTICLE 1), the District, Construction Manager or Architect may issue a valued Punch List, reject the Punch List Time Extension and deduct 150% of the valued Punch List pursuant to Article 2.2 and proceed to Close-Out the Project. Contractor shall cease work on the Project and proceed to complete Contractor's Retention Payment Application and complete the Work for the Project required pursuant to Article 9.11.3.

9.9.1.4 *District Rejection of Written Request for Punch List Time Extensions.* Following sixty (60) Days of Punch List under Article 9.9.1.3, the District has the option of rejecting Punch List Time Extension requests. The District may proceed under Article 2.2 and deduct the value of remaining Punch List Work pursuant to Article 2.2. If the District rejects the Punch List Time Extension request then Contractor shall cease Work on the Project and proceed to Final Inspection pursuant to Article 9.11.2.

9.9.1.5 *Punch List Liquidated Damages to Compensate for Added District Project Costs.* If the total time utilized for Punch List exceeds sixty (60) days [the thirty (30) day period under Article 9.9.1.3 plus an additional thirty (30) day period that has been requested in writing], and the District grants an additional written Punch List Time Extension that exceeds sixty (60) days of Punch List, then Contractor shall be charged Liquidated Damages of at least \$750 per day for continued Punch List Work to partially compensate the Inspector, Architect, and Construction Manager's extended time on the Project. This Punch List Liquidated Damage number is based on anticipated cost for an Inspector on site and additional costs for the Architect and Construction Manager to reinspect Punch List items and perform the administration of the Close-out.

Contractor received thirty (30) days without any charges for Punch List Liquidated Damages and is placed on notice pursuant to this Article 9.9.1.5 that \$750 is due for each day of Punch List that exceeds sixty (60) days at \$750, a cost much lower than typical (and actual) costs for Inspection, Architect and Construction Manager time required during Punch List. Starting at ninety (90) days of Punch List (an excessive number of days to complete Punch List), the District shall be entitled to adjust Punch List Liquidated Damages to an estimate of the actual costs incurred to oversee, monitor and inspect the Punch List. If costs exceed \$750 per day, the anticipated extended contract charges for Inspection, Architect, Construction Manager, and any other costs that will be incurred due to the extended Punch List shall be itemized and a daily rate of Punch List Liquidated Damages shall be presented in writing to the Contractor within five (5) days following the receipt of a written request for Punch List Time Extension by the Contractor that extends the Punch List time beyond ninety (90) days. This written notice of actual Punch List Liquidated Damages may be provided to the Contractor at any time following the first written request for Punch List Time extension requested under Article 9.9.1.3. The adjusted actual Punch List Liquidated Damage amount shall be applicable as Punch List Liquidated Damages commencing on the ninetieth (90th) day of Punch List.

9.9.2 Close-Out Requirements for Final Completion of the Project

- a. Utility Connections. Buildings shall be connected to water, gas, sewer, and electric services, complete and ready for use. Service connections shall be made and existing services reconnected
- b. As-Built Up to Date and Complete. The intent of this procedure is to obtain an exact "As-Built" record of the Work upon completion of the project. The following information shall be carefully and correctly drawn on the prints and all items shall

GENERAL CONDITIONS

be accurately located and dimensioned from finished surfaces of building walls on all As-Built Drawings

1. The exact location and elevations of all covered utilities, including valves, cleanouts, etc. must be shown on As-Built Drawings
2. Contractor is liable and responsible for inaccuracies in As-Built Drawings, even though they become evident at some future date.
3. Upon completion of the Work and as a condition precedent to approval of Retention Payment, Contractor shall obtain the Inspector's approval of the "As-Built" information. When completed, Contractor shall deliver corrected sepias and/or a Diskette with an electronic file in a format acceptable to the District.
4. District may withhold the cost to hire a draftsman and potholing and testing service to complete Record As-Built Drawings at substantial cost if the Contractor does not deliver a complete set of Record As-Built Drawings. This shall result in withholding of between \$10,000 to \$20,000 per building that does not have a corresponding Record As Built Drawing.

c. Any Work not installed as originally indicated on Drawings

d. All DSA Close-Out requirements (See DSA Certification Guide) Contractor is also specifically directed to Item ARTICLE 1 in the DSA Certification Guide and the applicable certificates for the DSA-311 form.

e. Submission of Form 6-C. Contractor shall be required to execute a Form 6-C as required under Title 24 Sections 4-343. The Contractor understands that the filing with DSA of a Form 6-C is a requirement to obtain final DSA Approval of the construction by Contractor and utilized to verify under penalty of perjury that the Work performed by Contractor complies with the DSA approved Contract Documents. The failure to file a DSA Form 6C has two consequences. First, the Construction of the Project will not comply with the design immunity provisions of Government Code section 830.6 and exposes the District and the individual Board members to personal liability for injuries that occur on the Project.

Secondly , under DSA IR A-20, since the Project cannot be Certified by DSA, no future or further Projects will be authorized so Contractor will have essentially condemned the campus from any future modernization or addition of new classrooms through their failure to file the DSA Form 6C.

1. *Execution of the DSA Form 6-C is Mandatory.* Refusal to execute the Form 6-C, which is a Final DSA Verified Report that all Work performed complies with the DSA approved Contract Documents is a violation of Education Code section 17312 and shall be referred to the Attorney General for Prosecution.
2. *Referral to the District Attorney for Extortion.* If the Contractor's refusal to execute the DSA Form 6C is to leverage a Dispute, Claim or Litigation,

GENERAL CONDITIONS

then the matter shall also be referred to the District Attorney for prosecution for extortion.

3. *Contractor shall be Responsible for All Costs to Certify the Project.* The District may certify the Project complies with Approved Plans and Specifications by utilizing the procedures under the Project Certification Guide (located at the DSA website). All costs for professionals, inspection, and testing required for an alternate Project Certification shall be the Contractor's responsibility and the District reserves its right to institute legal action against the Contractor and Contractor's Surety for all costs to certify the Project and all costs to correct Non-Compliant Work that is discovered during the Alternate Certification Process.
- f. ADA Work that must be corrected to receive DSA certification. See Article 12.2.
- g. Maintenance Manuals. At least thirty (30) days prior to final inspection, three (3) copies of complete operations and maintenance manuals, repair parts lists, service instructions for all electrical and mechanical equipment, and equipment warranties shall be submitted, along with indexed PDF files. All installation, operating, and maintenance information and Drawings shall be bound in 8½" x 11" binders. Provide a table of contents in front and all items shall be indexed with tabs. Each manual shall also contain a list of Subcontractors, with their addresses and the names of persons to contact in cases of emergency. Identifying labels shall provide names of manufactures, their addresses, ratings, and capacities of equipment and machinery.
 1. Maintenance manuals shall also be delivered in electronic media for the Project. Any demonstration videos shall also be provided on electronic media.
- h. Inspection Requirements. Before calling for final inspection, Contractor shall determine that the following Work has been performed:
 1. The Work has been completed;
 2. All fire/ life safety items are completed and in working order;
 3. Mechanical and electrical Work complete, fixtures in place, connected and tested;
 4. Electrical circuits scheduled in panels and disconnect switches labeled;
 5. Painting and special finishes complete;
 6. Doors complete with hardware, cleaned of protective film relieved of sticking or binding and in working order;
 7. Tops and bottoms of doors sealed;
 8. Floors waxed and polished as specified;

GENERAL CONDITIONS

9. Broken glass replaced and glass cleaned;
10. Grounds cleared of Contractor's equipment, raked clean of debris, and trash removed from Site;
11. Work cleaned, free of stains, scratches, and other foreign matter, replacement of damaged and broken material;
12. Finished and decorative work shall have marks, dirt and superfluous labels removed;
13. Final cleanup, as in Article ARTICLE 1;
14. All Work pursuant to Article 9.11.2; and
15. Furnish a letter to District stating that the District's Representative or other designated person or persons have been instructed in working characteristics of mechanical and electrical equipment.

9.9.3 Costs of Multiple Inspections

More than two (2) requests of the District to make inspections required under Article 9.9.1 shall be considered an additional service of Architect, Inspector, Engineer or other consultants shall be the Contractor's responsibility pursuant to Article 4.5 and all subsequent costs will be prepared as a Deductive Change Order.

9.10 **PARTIAL OCCUPANCY OR USE**

9.10.1 District's Rights

The District may occupy or use any completed or partially completed portion of the Work at any stage. The District and the Contractor shall agree in writing to the responsibilities assigned to each of them for payments, security, maintenance, heat, utilities, damage to the Work, insurance, the period for correction of the Work, and the commencement of warranties required by the Contract Documents. If District and Contractor cannot agree as to responsibilities such disagreement shall be resolved pursuant to Article 4.6. When the Contractor considers a portion complete, the Contractor shall prepare and submit a Punch List to the District as provided under Article 9.9.1.

9.10.2 Inspection Prior to Occupancy or Use

Immediately prior to such partial occupancy or use, the District, the Contractor, and the Architect shall jointly inspect the area to be occupied or portion of the Work to be used in order to determine and record the condition of the Work.

9.10.3 No Waiver

Unless otherwise agreed upon, partial occupancy or use of a portion or portions of the Work shall not constitute acceptance of Work not complying with the requirements of the Contract Documents.

GENERAL CONDITIONS

9.11 COMPLETION AND FINAL PAYMENT

9.11.1 Final Payment (90% Billing if Substantially Complex Finding and 95% Billing If No Finding Is Made)

The following items must be completed before the Final Payment Application will be accepted for processing at Substantial Completion of the Project:

- a. Inspector sign-off of each item in the DSA 152 Project Inspection Card;
- b. The Project has reached the Punch List items under Article 9.9.1.2 and the Project has been determined to be Substantially Complete under Article 1.1.46;
- c. Removal of temporary facilities and services;
- d. Testing, adjusting and balance records are complete;
- e. Removal of surplus materials, rubbish, and similar elements;
- f. Changeover of door locks;
- g. Deductive items pursuant to Article 9.6 and Article 2.2; and
- h. Completion and submission of all final Change Orders for the Project.

9.11.2 Final Inspection (Punch List Completion)

Contractor shall comply with Punch List procedures under Article 9.9.1.1, and maintain the presence of Project Superintendent and Project Manager (not replacement project superintendent or project manager) until the Punch List is complete to ensure proper and timely completion of the Punch List. Under no circumstances shall Contractor demobilize its forces prior to completion of the Punch List.

Upon completion of the Work under Article 9.9.1, the Contractor shall notify the District and Architect, who shall again inspect such Work. If the Architect and the District find the Work contained in the Punch List acceptable under the Contract Documents, the Work shall have reached Final Completion. Architect shall notify Contractor, who shall then submit to the Architect its Application for Retention Payment. This Application for Retention Payment shall contain any deductions under Article 9.6, including but not limited to incomplete Punch List items under Article 9.9.1.

Upon receipt and approval of Application for Retention Payment, the Architect shall issue a Form 6 stating that to the best of its knowledge, information, and belief, and on the basis of its observations, inspections, and all other data accumulated or received by the Architect in connection with the Work, such Work has been completed in accordance with the Contract Documents. The District shall thereupon inspect such Work and either accept the Work as complete or notify the Architect and the Contractor in writing of reasons why the Work is not complete. Upon acceptance of the Work of the Contractor as fully complete (which, absent unusual circumstances, will occur when the Punch List items have been satisfactorily completed), the District shall record a Notice of Completion with the County Recorder, and the Contractor shall, upon receipt of payment from the District, pay the amounts due Subcontractors.

GENERAL CONDITIONS

If the Architect and the District find that the Work contained in the Punch List is unacceptable, then Contractor shall issue a valued Punch List within 5 days after the date the Punch List time ends. If Contractor does not issue such a list, the District or Architect may issue a valued Punch List to the Contractor and withhold up to 150% of the value of the Punch List Work pursuant to Article 2.2 of this Agreement.

9.11.3 Retainage (100% Billing for the Entire Project)

The retainage, less any amounts disputed by the District or which the District has the right to withhold pursuant to the Contract Documents (including but not limited to incomplete Punch List items under Article 9.9.1), shall be paid after approval by the District of the Application for Retention Payment, after the satisfaction of the conditions set forth in Article 9, the Final Inspection under Article 9.11.2 is completed, and after thirty-five (35) days after the acceptance of the Work and recording of the Notice of Completion by District. No interest shall be paid on any retainage, or on any amounts withheld due to a failure of the Contractor to perform, in accordance with the terms and conditions of the Contract Documents, except as provided to the contrary in any escrow agreement between the District and the Contractor.

- a. Procedures for Application for Retention Payment. The following conditions must be fulfilled prior to release of Retention Payment:
 1. A full and final waiver or release of all stop notices in connection with the Work shall be submitted by Contractor, including a release of stop notice in recordable form, together with (to the extent permitted by law) a copy of the full and final release of all Stop Notice rights.
 2. The Contractor shall have made all corrections, including all Punch List Items, to the Work which are required to remedy any defects therein, to obtain compliance with the Contract Documents or any requirements of applicable codes and ordinances, or to fulfill any of the orders or directions of District required under the Contract Documents.
 3. Each Subcontractor shall have delivered to the Contractor all written guarantees, warranties, applications, releases from the Surety and warranty bonds (if applicable) required by the Contract Documents for its portion of the Work.
 4. Contractor must have completed all requirements set forth in Article 9.9
 5. Contractor must have issued a Form 6C for the Project.
 6. The Contractor shall have delivered to the District all manuals and materials required by the Contract Documents.
 7. The Contractor shall have completed final clean up as required by Article ARTICLE 1

GENERAL CONDITIONS

8. Contractor shall have all deductive items under Article 9.6 and Article 2.2 submitted as part of the Retention Payment.

9.11.4 Recording of a Notice of Completion After Punch List Period and Final Inspection.

When the Work, or designated portion thereof, is complete or the District has completed the Article 9.6 and/or the Article 2.2 process, whichever occurs first, the District will file either a Notice of Completion or a Notice of Completion noting valued Punch List items. Valued Punch List items will be deducted from the Retention Payment.

During the time when Work is being performed on the Punch List, the Project does not meet the definition of "Complete" under Public Contract Code section 7107(c)(1) even if there is "beneficial occupancy" of the Project since that has been no "cessation of labor" on the Project. Completion of Punch List under this Article is not "testing, startup, or commissioning by the public entity or its agent." In other words, the continuing Punch List Work is Contractor labor on the Project until each and every item of Punch List Work is complete or the time periods under Article 9.9.1 have expired.

9.11.5 Warranties

Warranties required by the Contract Documents shall commence on the date of Completion of the entire Work. Warranty periods DO NOT commence at Substantial Completion or when a particular Subcontractor work is complete. No additional charges, extras, Change Orders, or Claims may be sought for warranties commencing from the Notice of Completion.

District shall have the right to utilize equipment, test, and operate as necessary for acclimation, or testing without voiding or starting warranties. Taking beneficial occupancy shall not start warranties except in the case where the District agrees, in writing, that warranties shall commence running or where the District is taking phased occupancy of specific buildings or areas and completes separate Punch Lists as further addressed in Article 4.2.7.

9.11.6 Time for Submission of Application for Final Payment and Retention Payment (Unilateral Processing of Final and Retention Payment Application).

If Contractor submits a Final Payment Application which fails to include deductive items under Article 9.6, the District or Architect shall note this defective request for Final Payment Application. The Contractor shall be notified that specific deductive items shall be included in the Final Payment Application. If Contractor either continues to submit the Final Payment Application without deductive items under Article 9.6, or a period of 14 calendar days passes after Contractor is provided written notice of deductive items for inclusion in Final Payment Application, then District may either alter the Final Payment Application and recalculate the math on the Final Payment Application to address the Article 9.6 deductive items or process a unilateral Final Payment Application.

9.11.7 Unilateral Release of Retention

After the recordation of the Notice of Completion, or within sixty (60) days following the completion of the Punch List or the expiration of the time for completion of Punch List under Article 9.9.1, if Contractor does not make an Application for Release of Retention, the District may unilaterally release retention less any deducts under Article 9.6 and/or Article 2.2, withholds due to stop notices, or withholdings due to other defective Work on the Project. District may also choose to unilaterally release Retention after deduction of 150% of any disputed items, which may also include items under Article 9.6

GENERAL CONDITIONS

and 2.2. If a deduction pursuant to Article 9.6 is made from Retention, a letter deducting specific valued items shall be considered a notice of Default under the terms of the Escrow Agreement.

9.12 **SUBSTITUTION OF SECURITIES**

The District will permit the substitution of securities in accordance with the provisions of Public Contract Code section 22300 as set forth in the form contained in the Bid Documents.

GENERAL CONDITIONS

ARTICLE 10 PROTECTION OF PERSONS AND PROPERTY

10.1 SAFETY PRECAUTIONS AND PROGRAMS

10.1.1 Contractor Responsibility

The Contractor shall be responsible for all damages to persons or property that occur as a result of its fault or negligence in connection with the prosecution of this Contract and shall take all necessary measures and be responsible for the proper care and protection of all materials delivered and Work performed until completion and final acceptance by the District. All Work shall be solely at the Contractor's risk, with the exception of damage to the Work caused by "acts of God" as defined in Public Contract Code section 7105(b)(2).

Contractor shall take, and require Subcontractor to take, all necessary precautions for safety of workers on the Work and shall comply with all applicable federal, state, local and other safety laws, standards, orders, rules, regulations, and building codes to prevent accidents or injury to persons on, about, or adjacent to premises where Work is being performed and to provide a safe and healthful place of employment. In addition to meeting all requirements of OSHA, Cal-OSHA, state, and local codes, Contractor shall furnish, erect and properly maintain at all times, as directed by District or Architect or required by conditions and progress of Work, all necessary safety devices, safeguards, construction canopies, signs, audible devices for protection of the blind, safety rails, belts and nets, barriers, lights, and watchmen for protection of workers and the public, and shall post danger signs warning against hazards created by such features in the course of construction. Contractor shall designate a responsible member of its organization on the Work, whose duty shall be to post information regarding protection and obligations of workers and other notices required under occupational safety and health laws, to comply with reporting and other occupational safety requirements, and to protect the life, safety and health of workers. The name and position of person so designated shall be reported to District by Contractor. Contractor shall correct any violations of safety laws, rules, orders, standards, or regulations. Upon the issuance of a citation or notice of violation by the Division of Occupational Safety and Health, such violation shall be corrected promptly.

10.1.2 Subcontractor Responsibility

Contractor shall require that Subcontractors participate in, and enforce, the safety and loss prevention programs established by the Contractor for the Project, which will cover all Work performed by the Contractor and its Subcontractors. Each Subcontractor shall designate a responsible member of its organization whose duties shall include loss and accident prevention, and who shall have the responsibility and full authority to enforce the program. This person shall attend meetings with the representatives of the various Subcontractors employed to ensure that all employees understand and comply with the programs.

10.1.3 Cooperation

All Subcontractors and material or equipment suppliers shall cooperate fully with Contractor, the District, and all insurance carriers and loss prevention engineers.

10.1.4 Accident Reports

GENERAL CONDITIONS

Subcontractors shall immediately, within two (2) days, report in writing to the Contractor all accidents whatsoever arising out of, or in connection with, the performance of the Work, whether on or off the Site, which caused death, personal injury, or property damage, giving full details and statements of witnesses. In addition, if death or serious injuries or serious damages are caused, the accident shall be reported within four (4) days by telephone or messenger. Contractor shall thereafter immediately, within two (2) days, report the facts in writing to the District and the Architect giving full details of the accident.

10.1.5 First-Aid Supplies at Site

The Contractor will provide and maintain at the Site first-aid supplies which complies with the current Occupational Safety and Health Regulations.

10.1.6 Material Safety Data Sheets and Compliance with Proposition 65

Contractor is required to have material safety data sheets available in a readily accessible place at the job site for any material requiring a material safety data sheet per the Federal "hazard communication" standard, or employees' "right-to-know law." The Contractor is also required to properly label any substance brought into the job site, and require that any person working with the material, or within the general area of the material, is informed of the hazards of the substance and follows proper handling and protection procedures.

Contractor is required to comply with the provisions of California Health and Safety Code section 25249, et seq., which requires the posting and giving of notice to persons who may be exposed to any chemical known to the State of California to cause cancer. The Contractor agrees to familiarize itself with the provisions of this Section, and to comply fully with its requirements.

10.1.7 Non-Utilization of Asbestos Material

NO ASBESTOS OR ASBESTOS-CONTAINING PRODUCTS SHALL BE USED IN THIS CONSTRUCTION OR IN ANY TOOLS, DEVICES, CLOTHING, OR EQUIPMENT USED TO AFFECT THIS CONSTRUCTION.

Asbestos and/or asbestos-containing products shall be defined as all items containing, but not limited to, chrysotile, amosite, anthophyllite, tremolite, and antinolite.

Any or all material containing greater than one-tenth of one percent (>.1%) asbestos shall be defined as asbestos-containing material.

All Work or materials found to contain asbestos or Work or material installed with asbestos-containing equipment will be immediately rejected and this Work will be removed at no additional cost to the District.

Decontamination and removal of Work found to contain asbestos or Work installed with asbestos-containing equipment shall be done only under supervision of a qualified consultant, knowledgeable in the field of asbestos abatement and accredited by the Environmental Protection Agency.

The asbestos removal contractor shall be an EPA accredited contractor qualified in the removal of asbestos and shall be chosen and approved by the asbestos consultant, who shall have sole discretion and final determination in this matter.

GENERAL CONDITIONS

The asbestos consultant shall be chosen and approved by the District, who shall have sole discretion and final determination in this matter.

The Work will not be accepted until asbestos contamination is reduced to levels deemed acceptable by the asbestos consultant.

Interface of Work under this Contract with Work containing asbestos shall be executed by the Contractor at his risk and at his discretion, with full knowledge of the currently accepted standards, hazards, risks, and liabilities associated with asbestos work and asbestos-containing products. By execution of this Contract, the Contractor acknowledges the above and agrees to hold harmless District and its assigns for all asbestos liability which may be associated with this work and agrees to instruct his employees with respect to the above-mentioned standards, hazards, risks, and liabilities.

10.2 SAFETY OF PERSONS AND PROPERTY

10.2.1 The Contractor

The Contractor shall take reasonable precautions for the safety of, and shall provide reasonable protection to prevent damage, injury, or loss to:

- a. Employees on the Work and other persons who may be affected thereby;
- b. The Work, material, and equipment to be incorporated therein, whether in storage on or off the Site, under the care, custody, or control of the Contractor or the Contractor's Subcontractors or Sub-subcontractors; and
- c. Other property at the Site or adjacent thereto such as trees, shrubs, lawns, walks, pavement, roadways, structures, and utilities not designated for removal, relocation, or replacement in the course of construction.

Contractor is constructive owner of Project site as more fully discussed in Article 6.2.

10.2.2 Contractor Notices

The Contractor shall give notices and comply with applicable laws, ordinances, rules, regulations, and lawful orders of public authorities bearing on the safety of persons or property or their protection from damage, injury, or loss.

10.2.3 Safety Barriers and Safeguards

The Contractor shall erect and maintain, as required by existing conditions and performance of the Contract, reasonable safeguards for safety and protection, including posting danger signs and other warnings against hazards, promulgating safety regulations, and notifying owners and users of adjacent sites and utilities.

10.2.4 Use or Storage of Hazardous Material

When use or storage of explosives, other hazardous materials or equipment, or unusual methods are necessary for execution of the Work, the Contractor shall exercise utmost care and carry on such activities under supervision of properly qualified personnel. The Contractor shall notify the District

GENERAL CONDITIONS

any time that explosives or hazardous materials are expected to be stored on Site. Location of storage shall be coordinated with the District and local fire authorities.

10.2.5 Protection of Work

The Contractor and Subcontractors shall continuously protect the Work, the District's property, and the property of others, from damage, injury, or loss arising in connection with operations under the Contract Documents. The Contractor and Subcontractors, at their own expense, shall make good any such damage, injury, or loss, except such as may be solely due to, or caused by, agents or employees of the District.

The Contractor, at Contractor's expense, will remove all mud, water, or other elements as may be required for the proper protection and prosecution of its Work.

Contractor shall take adequate precautions to protect existing roads, sidewalks, curbs, pavements, utilities, adjoining property and structures (including, without limitation, protection from settlement or loss of lateral support), and to avoid damage thereto, and repair any damage thereto caused by construction operations. All permits, licenses, or inspection fees required for such repair Work shall be obtained and paid for by Contractor.

10.2.6 Requirements for Existing Sites

Contractor shall (unless waived by the District in writing):

- a. When performing construction on existing sites, become informed and take into specific account the maturity of the students on the Site; and perform Work which may interfere with school routine before or after school hours, enclose working area with a substantial barricade, and arrange Work to cause a minimum amount of inconvenience and danger to students and faculty in their regular school activities. The Contractor shall comply with Specifications and directives of the District regarding the timing of certain construction activities in order to avoid unnecessary interference with school functioning.
- b. Avoid performing any Work that will disturb students during testing.
- c. Provide substantial barricades around any shrubs or trees indicated to be preserved.
- d. Deliver materials to building area over route designated by Architect.
- e. Take preventive measures to eliminate objectionable dust, noise, or other disturbances.
- f. Confine apparatus, the storage of materials, and the operations of workers to limits indicated by law, ordinances, permits or directions of Architect; and not interfere with the Work or unreasonably encumber premises or overload any structure with materials; and enforce all instructions of District and Architect regarding signs, advertising, fires, and smoking and require that all workers comply with all regulations while on the Project site.

GENERAL CONDITIONS

- g. Take care to prevent disturbing or covering any survey markers, monuments, or other devices marking property boundaries or corners. If such markers are disturbed by accident, they shall be replaced by an approved land surveyor or civil engineer and all maps and records required therefrom shall be filed with county and local authorities, at no cost to the District. All filing and plan check fees shall be paid by Contractor.
- h. Provide District on request with Contractor's written safety program and safety plan for each site.

10.2.7 Shoring and Structural Loading

The Contractor shall not impose structural loading upon any part of the Work under construction or upon existing construction on or adjacent to the Site in excess of safe limits, or loading such as to result in damage to the structural, architectural, mechanical, electrical, or other components of the Work. The design of all temporary construction equipment and appliances used in construction of the Work and not a permanent part thereof, including, without limitation, hoisting equipment, cribbing, shoring, and temporary bracing of structural steel, is the sole responsibility of the Contractor. All such items shall conform with the requirements of governing codes and all laws, ordinances, rules, regulations, and orders of all authorities having jurisdiction. The Contractor shall take special precautions, such as shoring of masonry walls and temporary tie bracing of structural steel Work, to prevent possible wind damage during construction of the Work. The installation of such bracing or shoring shall not damage the Work in place or the Work installed by others. Any damage which does occur shall be promptly repaired by the Contractor at no cost to the District.

10.2.8 Conformance within Established Limits

The Contractor and Subcontractors shall confine their construction equipment, the storage of materials, and the operations of workers to the limits indicated by laws, ordinances, permits, and the limits established by the District or the Contractor, and shall not unreasonably encumber the premises with construction equipment or materials.

10.2.9 Subcontractor Enforcement of Rules

Subcontractors shall enforce the District's and the Contractor's instructions, laws, and regulations regarding signs, advertisements, fires, smoking, the presence of liquor, and the presence of firearms by any person at the Site.

10.2.10 Site Access

The Contractor and the Subcontractors shall use only those ingress and egress routes designated by the District, observe the boundaries of the Site designated by the District, park only in those areas designated by the District, which areas may be on or off the Site, and comply with any parking control program established by the District, such as furnishing license plate information and placing identifying stickers on vehicles.

10.2.11 Security Services.

The Contractor shall be responsible for providing security services for the Site as needed for the protection of the Site and as determined in the District's sole discretion.

GENERAL CONDITIONS

10.3 EMERGENCIES

10.3.1 Emergency Action

In an emergency affecting the safety of persons or property, the Contractor shall take any action necessary, at the Contractor's discretion, to prevent threatened damage, injury, or loss. Additional compensation or extension of time claimed by the Contractor on account of an emergency shall be determined as provided in Article 7.

10.3.2 Accident Reports

The Contractor shall promptly report in writing to the District all accidents arising out of or in connection with the Work, which caused death, personal injury, or property damage, giving full details and statements of any witnesses in conformance with Article 10.1.4. In addition, if death, serious personal injuries, or serious property damages are caused, the accident shall be reported in accordance with Article 10.1.4, immediately by telephone or messenger to the District.

10.4 HAZARDOUS MATERIALS

10.4.1 Discovery of Hazardous Materials

In the event the Contractor encounters or suspects the presence on the job site of material reasonably believed to be asbestos, polychlorinated biphenyl (PCB), or any other material defined as being hazardous by § 25249.5 of the California Health and Safety Code, which has not been rendered harmless, the Contractor shall immediately stop Work in the area affected and report the condition to the District and the Architect in writing, whether or not such material was generated by the Contractor or the District. The Work in the affected area shall not thereafter be resumed, except by written agreement of the District and the Contractor, if in fact the material is asbestos, polychlorinated biphenyl (PCB), or other hazardous material, and has not been rendered harmless. The Work in the affected area shall be resumed only in the absence of asbestos, polychlorinated biphenyl (PCB), or other hazardous material, or when it has been rendered harmless by written agreement of the District and the Contractor.

10.4.2 Hazardous Material Work Limitations

In the event that the presence of hazardous materials is suspected or discovered on the Site (except in cases where asbestos and other hazardous material Work in the Contractor's responsibility), the District shall retain an independent testing laboratory to determine the nature of the material encountered and whether corrective measures or remedial action is required. The Contractor shall not be required pursuant to Article 7 to perform without consent any Work in the affected area of the Site relating to asbestos, polychlorinated biphenyl (PCB), or other hazardous material, until any known or suspected hazardous material has been removed, or rendered harmless, or determined to be harmless by District, as certified by an independent testing laboratory and approved by the appropriate government agency.

10.4.3 Indemnification by Contractor for Hazardous Material Caused by Contractor

In the event the hazardous materials on the Project Site is caused by the Contractor, the Contractor shall pay for all costs of testing and remediation, if any, and shall compensate the District for any additional costs incurred as a result of Contractor's generation of hazardous material on the Project Site. In addition, the Contractor shall defend, indemnify and hold harmless District and its agents, officers,

GENERAL CONDITIONS

and employees from and against any and all claims, damages, losses, costs and expenses incurred in connection with, arising out of, or relating to, the presence of hazardous material on the Project Site.

10.4.4 Terms of Hazardous Material Provision

The terms of this Hazardous Material provision shall survive the completion of the Work and/or any termination of this Contract.

GENERAL CONDITIONS

ARTICLE 11 INSURANCE AND BONDS

EXHIBIT A OWNER CONTROLLED INSURANCE PROGRAM (OCIP)

1.1 INTRODUCTION

The **District**, hereinafter called the “Owner” has elected, at its sole discretion, to implement an Owner Controlled Insurance Program (“OCIP”) under the Statewide Educational Wrap Up Program (“SEWUP”). The SEWUP Joint Powers Authority (“JPA”) will be providing the OCIP on behalf of the Owner. All terms and conditions of the SEWUP Contractual Provisions will apply during the term of the contract.

The SEWUP JPA will provide Workers’ Compensation, Employer’s Liability, General & Excess Liability, Contractor’s Pollution Liability, and Builder’s Risk insurance for all Enrolled Contractors (and their Enrolled Subcontractors of every tier) and other designated parties for work performed at the Project Site (hereinafter called “Project”). The Owner agrees to pay all premiums associated with the OCIP, unless otherwise stated in this section and in other contract documents.

Insurance coverage provided under the OCIP is limited in scope and specific to Work performed after the inception date of enrollment into the OCIP. Labor and ongoing operations related to offsite locations are not covered by the OCIP. In addition to any insurance provided by the Owner, all Contractors/Subcontractors will be responsible for providing certain insurance as specified in section 11. The Owner recommends that Contractors discuss the OCIP with their insurance agents, brokers or consultants to assure that other proper coverages are maintained, prior to contract acceptance.

Keenan & Associates, hereinafter called “Program Administrator”, shall administer the OCIP on behalf of the SEWUP JPA. At all times, all Contractors/Subcontractors, shall (a) cooperate with Owner, Program Administrator, and all OCIP insurers, as applicable, and their respective consultants, agents and representatives, in its or their administration of the OCIP and all other terms and conditions described herein and (b) comply with the terms, conditions, warranties, and subjectivities of the insurance policies provided pursuant to the OCIP, including, without limitation, any and all directives and requirements of Owner’s and the OCIP insurers’ respective consultants, agents and representatives, including, without limitation, any directive or requirement relating to loss control, and quality control, and the closure to Owner’s satisfaction of open items on any and all quality control checklists and inventories.

A. Participation in the OCIP

Participation in the OCIP is mandatory but not automatic. Each Eligible Contractor/Subcontractor must follow the guidelines, as specified in section 11.

Enrollment (Definition): An Eligible Contractor/Subcontractor is considered Enrolled once required documents are received, reviewed and processed by the OCIP Program Administrator to the insurer. (See Sections 11 and 11)

Contractor (Definition): Includes all vendors, suppliers, businesses, persons, or entities and entities which the Owner has engaged directly by contract to perform services relating to the Project.

Subcontractor (Definition): Includes all vendors’ suppliers, businesses, and other persons or entities that have been engaged by a Contractor to perform, or assist with the performance of, services relating to the Project.

Eligible (Definition): Includes all Contractors/Subcontractors providing direct labor on the Project, and excludes Ineligible Contractors, as defined below. Temporary labor services and leasing companies are to be treated as Eligible Contractors.

GENERAL CONDITIONS

Ineligible (Definition): Ineligible (Definition): It is not the intent to insure (but is not limited to): consultants; suppliers; abatement and/or removal of hazardous materials; vendors; materials dealers; surveyors; consultants; guard services; non-construction janitorial services; and truckers, including trucking to the Project where delivery is the only scope of work performed; contractors subbing out installation who are not performing labor on the project site; and contractors performing landscape maintenance (though landscape work itself is covered). Ineligible parties are required to ensure that any eligible subcontractors who provide on-site labor comply with the OCIP Enrollment. Any questions regarding a Contractor's status as "Eligible" or "Ineligible" should be referred by written request to Owner and approved by the Program Administrator.

EACH CONTRACTOR/SUBCONTRACTOR MUST INCLUDE THIS DOCUMENT WITH THEIR BID SPECIFICATIONS TO ANY AND ALL SUBCONTRACTORS. Any contractor/subcontractor's failure to comply with the OCIP Administrator and all OCIP requirements shall be considered non-compliant under the contract.

Enrollment of each Contractor's eligible Subcontractors is mandatory. Contractor shall notify Owner and the Program Administrator in writing of the identity of each Subcontractor, and shall cause each Subcontractor to notify the Program Administrator in writing of the identity of each of its Sub-subcontractors, prior to such parties' commencement of their portion of the Work and prior to their entry onto the Project. Subcontractors shall not be deemed enrolled until the Program Administrator and OCIP insurers receive and approve a completed Contract Enrollment Form, for each awarded contract. Enrollment is required prior to commencement of on-site activities but no contractor shall be enrolled sooner than 30 days prior to their start date. Each Subcontractor shall be solely responsible for any and all losses, damages, claims, liabilities, and suits arising out of such Subcontractor's failure to enroll, or delay in enrolling, any of its Subcontractors.

Unless otherwise directed by the Owner, Ineligible Contractors and Subcontractors will be required to maintain their own insurance for both on-site and off-site activities and will be required to participate in the Project Safety Program (**See Section 1.16**). Minimum Insurance and endorsement requirements are located in Section **11 & 11**.

B. Project Site and Offsite Premises

Coverages provided by the OCIP are Project Site specific. The Project Site shall be designated by the Owner. The Project Site consists of any and all projects that are endorsed to this policy, which includes the:

1. Ways and means adjoining the endorsed project site.
2. Adjacent locations to the endorsed projects sites where incidental operations are being performed, excluding permanent locations.

With the exception of 1 and 2 mentioned above, off-site locations, labor and ongoing operations are not covered by the OCIP. It will be the responsibility of each Contractor/Subcontractor to maintain off-site insurance, as identified in Section 11, which specifies coverage types and minimum limits. Contractor/Subcontractor will promptly furnish to the Owner, or its designated representative, Certificates of Insurance evidencing that all required insurance is in force.

1.2 PREQUALIFICATION & COST IDENTIFICATION

A. Contractor Pre-Qualification

Pursuant to Government Code Section 4420.5, Bidders must meet certain minimum standards in order to bid on the Owners' Project. The following qualification standards apply to ALL Bidding Contractors at time of bid opening:

GENERAL CONDITIONS

1. **Have an average Workers' Compensation Experience Modification Rate (EMR) of 1.25 or less over the last five (5) years.**
2. **Have Zero (0) Serious and Willful violations (Labor Code Section 6300) against them in the past five (5) years**
3. **Provide evidence of an Injury and Illness Prevention Program (IIPP). Evidence is required to be submitted after bid opening and prior to bid award.**

FAILURE TO MEET THESE MINIMUM STANDARDS SHALL DISQUALIFY THE BIDDER.

B. Contractor Insurance Cost Identification

Contractor's base bid shall exclude all costs for insurance coverages provided under the OCIP. If insurance cost is not removed, the bidder may not qualify as the lowest responsive bidder. The Bidder declares under penalty of perjury under California law, that the base bid excludes any costs relating to any insurance coverages afforded under the OCIP and that each subcontractor to the Bidder has similarly excluded costs for any insurance coverage afforded under the OCIP.

C. Change Order Pricing

All Contractors/Subcontractors declare, under penalty of perjury under California law, that the change order is priced to exclude any costs relating to any insurance coverage afforded under the OCIP.

1.3 OWNER-PROVIDED INSURANCE COVERAGES

CONTRACTOR/SUBCONTRACTOR SHOULD REFER TO THE ACTUAL POLICIES FOR DETAILS CONCERNING COVERAGE, EXCLUSIONS, AND LIMITATIONS. IN THE EVENT OF ANY CLAIM OR QUESTION REGARDING COVERAGE PROVIDED BY THE OCIP, THE ORIGINAL POLICIES WILL PREVAIL AS THE SOLE BINDING AGREEMENT. OCIP POLICIES AND PROJECT INSURANCE MANUAL ARE AVAILABLE UPON WRITTEN REQUEST TO THE PROGRAM ADMINISTRATOR.

OCIP coverage applies only to Work performed under the contract at the Project (see Section 11, 11 for definition). All Contractors must provide their own insurance for Automobile Liability and off-site locations, labor, and operations.

Such policies or programs may be amended from time to time, and the terms of such policies or programs, as amended, are incorporated herein by reference.

The Contractors/Subcontractors enrolled in the OCIP agree that the OCIP policies' limits of liability, coverage terms and conditions shall determine the scope of coverage provided by the OCIP.

A. Workers' Compensation and Employer's Liability Insurance, will be provided in accordance with applicable state laws, to all Enrolled Contractors/Subcontractors, each as named insured, and issued an individual policy) reflecting the following Limits of Liability:

Workers' Compensation:

- California Statutory Benefits

Employer's Liability:

- \$1,000,000 Bodily Injury each Accident
- \$1,000,000 Bodily Injury by Disease – Policy Limit
- \$1,000,000 Bodily Injury by Disease – Each Employee

1. Deductible: None
2. Exclusions: The known exclusions for this coverage are set forth on the table attached as . This is a summary and may not be exhaustive. The policy language may contain additional exclusionary

GENERAL CONDITIONS

language, limitations or carve-backs that are not identified on the table. It is the responsibility of the Contractor/Subcontractor to review the policy for the complete details of all exclusions.

3. Policy Term: The master policy effective date is October 1, 2017. The policy term is one year, with automatic one-year renewals until the Project is completed. The policy is intended to remain in effect for duration of the contractor's contractual work. Warranty work and post contract repair work is excluded. Each Contractor/Subcontractor is insured under the policy for the length of its work at the Project.

B. General and Excess Liability Insurance is written on an "Occurrence" form under master liability policies. Certificates of Insurance will be provided to all enrolled Contractors/Subcontractors as named insured, with the total limits of liability reflecting the following:

- \$ 75,000,000 Bodily Injury and Property Damage Liability
- \$145,000,000 General Aggregate
- \$ 75,000,000 Products and Completed Operations
- 10 Years Completed Operations

1. Deductible: None
2. Exclusions: The known exclusions for this coverage are set forth on the table attached as . This is a summary and may not be exhaustive. The policy language may contain additional exclusionary language, limitations or carve-backs that are not identified on the table. It is the responsibility of the Contractor/Subcontractor to review the policy for the complete details of all exclusions.
3. Policy Term:
 - a. The master policy effective date is October 1, 2017. The policy is intended to remain in effect for the length of the Project or the policy end date, whichever comes first.
 - b. Ten years Products and Completed Operations coverage.

C. Contractor's Pollution Liability, is written on an "Occurrence" form under a master liability policy. Certificates of Insurance will be provided to all enrolled Contractors/Subcontractors, as named insured, reflecting the following Limits of Liability:

- \$5,000,000 Per Occurrence / \$5,000,000 Policy Aggregate
- Defense costs included within limits

1. \$10,000 Deductible per Occurrence
2. Contractor/Subcontractor shall be liable, at its expense; to the extent claims payable are attributable to their acts or omissions and/or the acts or omissions of its Subcontractors of any tier or any other entity or person for whom it may be responsible. The deductible amount shall not be reimbursed by the OCIP Insurance Program or the District.
3. Exclusions: The known exclusions for this coverage are set forth on the table attached as . This is a summary and may not be exhaustive. The policy language may contain additional exclusionary language, limitations or carve-backs that are not identified on the table. It is the responsibility of the Contractor/Subcontractor to review the policy for the complete details of all exclusions.
4. Policy Term: The master policy effective date is October 1, 2017. The policy is intended to remain in effect for the length of the Project or the policy end date, whichever comes first.

D. Builder's Risk coverage will be in place during the Course of Construction at the Project. Such insurance shall be written on a repair or replacement cost basis, subject to exclusions, sub limits, property limitations and conditions. Such insurance shall include the interests of the Owner as named

GENERAL CONDITIONS

insured and enrolled Contractors/Subcontractors as additional insured’s. The deductible schedule is as follows:

New Construction & Renovation

| Deductible | Number of Buildings or Structures per Project | Total Insured Value (TIV) | Construction Class |
|--------------------------------|---|--|---|
| \$5,000 Deductible: | Projects with Single and Multiple Building(s) or Structure(s) | Up to \$15M | <ul style="list-style-type: none"> • Fire Resistive • Non Combustible • Masonry Concrete |
| | Projects with Multiple Building(s) or Structure(s) | Up to \$10M (No single building or structure greater than \$10mm in value) | <ul style="list-style-type: none"> • Joisted Masonry • Hybrid Construction |
| | Projects with No Vertical Construction (No Buildings or Structures) | | <ul style="list-style-type: none"> • Grading - Site Prep Only No Vertical Construction |
| \$10,000 Deductible: | Projects with Single and Multiple Building(s) or Structure(s) | \$15M to \$50M | <ul style="list-style-type: none"> • Fire Resistive • Non Combustible • Masonry Concrete |
| | Projects with Single Building or Structure | Up to \$25M | <ul style="list-style-type: none"> • Joisted Masonry • Hybrid Construction • Wood Frame |
| | Projects with Multiple Building(s) or Structure(s) | Up to \$10M (No single building or structure greater than \$10mm in value) | <ul style="list-style-type: none"> • Wood Frame |
| \$25,000*** Deductible: | Projects with Single and Multiple Building(s) or Structure(s) | \$50M & above | <ul style="list-style-type: none"> • Fire Resistive • Non Combustible • Masonry Concrete |
| | Single Building or Structure Projects | \$25M & above | <ul style="list-style-type: none"> • Joisted Masonry • Hybrid Construction • Wood Frame |

*** Structural and Non-Structural Renovation Projects with Single and Multiple Building(s) or Structure(s) – Deductibles are as per above categories, except in the event of Water Damage, where the deductible is \$25,000.

1. Contractor/Subcontractors shall be responsible for the applicable deductible. The deductible shall not be reimbursed by the OCIP Insurance Program or the District.
 2. Exclusions: The known exclusions for this coverage are set forth on the table attached as . This is a summary and may not be exhaustive. The policy language may contain additional exclusionary language, limitations or carve-backs that are not identified on the table. It is the responsibility of the Contractor/Subcontractor to review the policy for the complete details of all exclusions.
 3. Special Conditions: **All wood frame only projects are subject to Protective Safeguards as shown in EXCIBIT C.**
 4. Policy Term: The policy term is the term of the project.
- E. **OCIP Policies Establish OCIP Coverage.** The insurance coverages, limits of liability, definitions, terms, conditions, exclusions and limitations contemplated in these contractual provisions and the other contract documents are set forth in full in the OCIP insurance policies. The summary descriptions of such policies in these contractual provisions, in the Project Insurance Manual, or in any other contract document or elsewhere are not intended to be complete or to alter or amend any

GENERAL CONDITIONS

provisions of the actual OCIP policies. To the extent, if any, such descriptions herein or therein conflict with any such insurance policies, the provisions of the actual insurance policies shall govern. To the extent there are any other conflicts between or among the provisions of such insurance policies, these contractual provisions, the contract documents, or the Project Insurance Manual, then in descending order, the insurance policies shall govern, followed by these contractual provisions, the contract, the other contract documents, then the Project Insurance Manual. Contractor/Subcontractor acknowledges that it has had the opportunity to review the insurance policies as provided in [section11](#), and that it is relying solely on the provisions set forth in the insurance policies, and not upon any oral or written statement or reference in these contractual provisions, any other contract document, the Project Insurance Manual, or otherwise.

1.4 OCIP CERTIFICATES AND POLICIES

All Enrolled Contractors/Subcontractors will receive Certificates of Insurance for Workers' Compensation, General Liability, Excess Liability and Contractor's Pollution Liability coverages. Each enrolled Contractor/Subcontractor will receive their own Workers' Compensation policy. Program Administrator will provide a copy of the OCIP policies upon written request. Such policies or programs may be amended from time to time and the terms of such policies or programs, as they may be amended, are incorporated herein by reference. Contractors/Subcontractors hereby agree to be bound by the terms of coverage, as contained in such insurance policies and/or self-insurance programs.

1.5 CONTRACTOR/SUBCONTRACTOR RESPONSIBILITIES

Participation in the OCIP is mandatory but not automatic. Each Eligible Contractor /Subcontractor must comply with the following:

A. **Contractor Eligibility**, see Section11, **11** for definition.

B. **Enrollment Compliance**

An Eligible Contractor/Subcontractor is not enrolled until the Program Administrator and OCIP insurers receive and approve a completed *Contract Enrollment Form* (see EXHIBIT), for each awarded contract. Enrollment is required prior to commencement of on-site activities but no contractor shall be enrolled sooner than 30 days prior to their start date. Evidence of Insurance for Contractor/Subcontractor-Provided Insurance Coverage (see Sections [11](#) and 11) is a requirement and must be submitted with the completed *Contract Enrollment Form*.

Any Contractor/Subcontractor who enrolls in the OCIP after their start date must provide a No-Known-Loss Letter to the Program Administrator, along with the enrollment documentation. Late Enrollment is not guaranteed and must be approved and accepted by the insurance carrier. Upon approval, the Program Administrator will provide evidence of OCIP coverage to the Contractor/Subcontractor, as noted in [Section 11](#).

All Contractors/Subcontractors shall cooperate with, and require their Subcontractors to cooperate with, the Owner and the Program Administrator, in regards to the administration and operation of the OCIP.

C. **Contractor/Subcontractor Compliance with Other Forms and Procedures**

All Enrolled Contractors/Subcontractors are required to complete and submit the following forms:

1. **Project Site Monthly Payroll Report**

Project Site Monthly Payroll Reports (see [EXHIBIT D](#)) must be submitted to the Program Administrator monthly, until the completion of the contract. This report must summarize the unburdened payroll by Workers' Compensation Class Code. Certified payroll is not a requirement of the OCIP and cannot be accepted. If the Project Site Monthly Payroll Report is not submitted to Program Administrator monthly, payment can be withheld until the report is received.

GENERAL CONDITIONS

Contractor/Subcontractor agrees to keep and maintain accurate and classified records of their payroll for operations at the Project Site. This payroll information is submitted to the OCIP insurer. A carrier audit may be performed using the reported payroll and other supporting documents, as required by the California Workers Compensation Insurance Rating Bureau (WCIRB).

Workers' Compensation Insurance Rating Bureau Requirements

Once an Eligible Contractor/Subcontractor is enrolled into the OCIP, a separate Workers' Compensation Policy will be issued to them. All Enrolled Contractors/Subcontractors shall comply with the rules and regulations of the California Workers Compensation Insurance Rating Bureau (WCIRB).

2. Contractor's Completion Notice

Contractor's Completion Notice (see [EXHIBIT E](#)) must be submitted to the Program Administrator upon completion of work at the Project, which includes punch list items, but not warranty work. This form evidences all enrolled Contractors'/Subcontractors' actual start and completion dates, per each contract. This information is used to confirm that each Workers' Compensation Policy was issued with correct policy term dates, covering the Contractors/Subcontractors for the duration of their Work at the Project. This information is subsequently submitted to the Workers' Compensation Insurance Rating Bureau (WCIRB).

3. Project Insurance Manual

A Project Insurance Manual will be provided to all awarded Contractors/Subcontractors, which includes a Program Summary, Claims Reporting Instructions, Project Safety Guidelines, necessary forms, and contact information. Copies can be requested from the Program Administrator.

Contractor/Subcontractor Compliance with all aspects of the OCIP

All Contractors/Subcontractors further acknowledge and agree to comply fully and promptly with such safety, loss control, and quality control rules, requirements, and directives as may from time to time be promulgated by Owner, the Program Administrator and/or the OCIP insurers or any of its or their respective consultants, agents, or representatives. Nothing in this document or any other contract document or in the Project Insurance Manual, shall be deemed to render Owner or any of its affiliates of any tier an employer of Contractor/Subcontractor or any of its Subcontractors or any of its or their personnel or employees. Failure to comply will be considered non-performance under the contract.

It is the obligation of each Eligible Contractor/Subcontractor to enroll in the OCIP and to comply with all OCIP requirements set forth in these contractual provisions, in the OCIP insurance policies, in the Project Insurance Manual, and elsewhere in the contract documents. Contractor/Subcontractor shall provide each of its Subcontractors, among other things, with a copy of the Project Insurance Manual and a copy of these contractual provisions. Contractor/Subcontractor shall require in writing that each enrolling Subcontractor comply with, among other things, the provisions of the OCIP insurance policies, the Project Insurance Manual, and the contract documents. All such requirements shall be included in all subcontracts and sub-subcontracts with eligible parties. The failure of Contractor/Subcontractor or any other party to provide eligible Subcontractors with a copy of this document, the Project Insurance Manual, and/or all other applicable requirements shall not relieve any such Subcontractor of any of the obligations contained therein.

Contractor/Subcontractor shall keep and maintain accurate records and information in accordance with the requirements of the OCIP Insurer(s), the Project Administrator, the Project Insurance Manual, and the contract documents, and shall provide such records and information to Owner, the Program Administrator, and/or the OCIP insurers upon request.

GENERAL CONDITIONS

1.6 OCIP DISCLAIMER

The Owner does not warrant or represent that the OCIP coverages constitute an insurance program that completely addresses all the risks of the Contractors/Subcontractors. Prior to the commencement of work under the contract, it is the responsibility of all Contractors/Subcontractors to ensure that the OCIP coverages provided sufficiently address their insurance needs. Any additional insurance coverage purchased will be at Contractor’s/Subcontractor’s option and sole expense.

1.7 REQUIRED CONTRACTOR/SUBCONTRACTOR PROVIDED INSURANCE COVERAGES

For any work under this contract, and until completion and final acceptance of the work by the Owner, the Contractors/Subcontractors shall, at their own expense, promptly furnish Certificates of Insurance evidencing that coverage is in force and any required Additional Insured Endorsements to the Owner, with a copy to the Program Administrator for the following coverages, before commencing work on the Project.

- A. **Automobile Liability Insurance Requirements and Limits Are as Follows:** See Section 11 for Certificate Holder and Additional Insured Endorsement specifications. Automobile Liability Insurance must cover all vehicles owned by, hired by, or used on behalf of the Contractors/Subcontractors for both Project Site and off-site operations with the following minimum limits of liability:

Auto Liability Insurance Limits:

Enrolled Contractors/Subcontractors

| | | |
|---------------------------------|----------------------|-----------------------------------|
| <u>General/Prime Contractor</u> | <u>Subcontractor</u> | |
| <u>\$2,000,000</u> | \$1,000,000 | Bodily Injury and Property Damage |

Ineligible Contractors/Subcontractors – Not Enrolled

| | | |
|---------------------------------|----------------------|-----------------------------------|
| <u>General/Prime Contractor</u> | <u>Subcontractor</u> | |
| <u>\$2,000,000</u> | \$1,000,000 | Bodily Injury and Property Damage |

- B. **Workers’ Compensation and Employer’s Liability Insurance Limits:**

Workers’ Compensation –Statutory Benefits - All States

Employer’s Liability:

- \$1,000,000 Bodily Injury each Accident
- \$1,000,000 Bodily Injury by Disease – Policy Limit
- \$1,000,000 Bodily Injury by Disease – Each Employee

GENERAL CONDITIONS

C. General Liability Insurance, minimum limits of liability are as follows:

Eligible Contractors/Subcontractors

| <u>General/Prime Contractor</u> | <u>Subcontractor</u> | |
|---------------------------------|----------------------|--|
| <u>\$2,000,000</u> | \$1,000,000 | Bodily Injury and Property Damage |
| <u>\$2,000,000</u> | \$1,000,000 | Per Occurrence |
| <u>\$2,000,000</u> | \$1,000,000 | General Aggregate |
| <u>\$2,000,000</u> | \$1,000,000 | Products/Completed Operations Aggregate |
| <u>\$2,000,000</u> | \$1,000,000 | Personal/Advertising Injury Aggregate |

Ineligible Contractors / Subcontractors – Not Enrolled

| <u>General/Prime Contractor</u> | <u>Subcontractor</u> | |
|---------------------------------|----------------------|--|
| <u>\$2,000,000</u> | \$1,000,000 | Bodily Injury and Property Damage |
| <u>\$2,000,000</u> | \$1,000,000 | Per Occurrence |
| <u>\$2,000,000</u> | \$1,000,000 | General Aggregate |
| <u>\$2,000,000</u> | \$1,000,000 | Products/Completed Operations Aggregate |
| <u>\$2,000,000</u> | \$1,000,000 | Personal/Advertising Injury Aggregate |

D. Professional Liability Insurance: If Contractor's/Subcontractor's work requires design and/or design-assist services, or Contractor/Subcontractor performs professional services of any kind, Contractor/Subcontractor shall purchase and maintain, at its sole cost and expense, Professional Liability (Errors and Omissions) insurance for all professional services provided. This Professional Liability insurance shall include full prior acts coverage sufficient to cover the services under this agreement, with the following minimum limits of liability:

\$1,000,000 per Claim/Annual Aggregate

GENERAL CONDITIONS

Deductible or self-insured retention amount must not be greater than \$100,000 per claim, including coverage of contractual liability.

Professional Liability Insurance is to be maintained during the term of the contract and for so long as the insurance is reasonably available as provided herein, for a period of ten (10) years after completion of the services.

- E. **Environmental and Asbestos Abatement Coverages:** If the Contractor's/Subcontractor's scope of work involves the removal of asbestos, the removal/replacement of underground tanks, or the removal of toxic chemicals and substances, the Contractor/Subcontractor will be required to provide the following minimum limits of liability, for such exposures subject to requirements and approval of the Owner:

\$1,000,000 per Claim/Aggregate

- F. **Aircraft or Watercraft Liability Insurance:** If any Contractor/Subcontractor requires the use of Aircraft or Watercraft at the Project Site, the Contractor/Subcontractor shall purchase and maintain, or cause the operator of the Aircraft or Watercraft to purchase and maintain, Aircraft or Watercraft liability insurance. This must insure passengers and the General Public against personal injury, bodily injury or property damage arising out of the ownership, maintenance, use or entrustment to others. It includes Aircraft or Watercraft owned or operated by or rented or loaned to any insured. Use includes operation and "loading or unloading". Contractor/Subcontractor will be required to provide the following minimum limits of liability, for such exposures subject to requirements and approval of the Owner:

\$5,000,000 per Claim/Aggregate

1.8 REQUIRED CONTRACTOR/SUBCONTRACTOR CERTIFICATES OF INSURANCE AND ADDITIONAL INSURED ENDORSEMENTS

Certificates of Insurance and Additional Insured Endorsements acceptable to the Owner and Program Administrator must be filed with the Owner within ten (10) days after award of the contract to all Contractors/Subcontractors and prior to commencement of on-site activities.

All required insurance shall be maintained, without interruption, from the date of commencement of on-site activities, until the date of the final payment or expiration of any extended period, as set forth in this agreement. These certificates and additional insured endorsements required by Section 11 and 11 shall provide not less than thirty (30) days prior written notice to the Owner, with a copy to the Program Administrator, of any material change in the insurance, cancellation, or non-renewal.

Certificates of Insurance, the Project must be identified on the Certificate of Insurance in the "Description of Operations/Locations/Vehicles/Special Items" section. The Certificates of Insurance should name District, as the Certificate Holder, as specified below:

Certificate Holder: Liberty Union High School District

c/o Statewide Educational Wrap Up Program (SEWUP)
2355 Crenshaw Blvd., Suite 200
Torrance, CA 90501

Additional Insured Endorsements: The Owner must be specifically named on the Schedule of an Additional Insured Endorsement, under the section titled, "Name of Person or Organization", as specified below:

1. All Contractors/Subcontractors must provide an additional insured endorsement for automobile liability.

GENERAL CONDITIONS

2. Ineligible Contractors/Subcontractors must provide an additional insured endorsement on both the Automobile Liability and General Liability policies and a waiver of subrogation on workers' compensation.

Liberty Union High School District

c/o Statewide Educational Wrap Up Program (SEWUP)
2355 Crenshaw Blvd., Suite 200
Torrance, CA 90501

1.9 CONTRACTOR/SUBCONTRACTOR INSURANCE FOR PERSONAL PROPERTY AND EQUIPMENT

All Contractors/Subcontractors shall be solely responsible for any loss or damage to their personal property including, without limitation, their tools and equipment, mobile construction equipment, scaffolding, and temporary structures, whether owned, borrowed, used, leased or rented by any Contractor/Subcontractor. Contractors/Subcontractors may at their sole discretion, purchase and maintain insurance or self-insure such equipment and property, and any deductible in relation thereto shall be their sole responsibility. Any insurance, including self-insurance, shall be the Contractors'/Subcontractors' sole source of recovery in the event of a loss.

Any type of insurance or any increase of limits of liability not described in this Section, which the Contractors/Subcontractors require for their own protection or on account of any statute, will be their own responsibility and at their expense.

1.10 ASSIGNMENT OF RETURN PREMIUMS

The Owner will be responsible for the payment of all premiums associated solely with the OCIP and will be the sole recipient of any dividend(s) and/or return premium(s) generated by the OCIP.

1.11 WAIVER OF SUBROGATION AND OWNER INDEMNIFICATION

With respect to their work on the Project:

1. Owner waives all rights of subrogation and recovery against the Contractors/Subcontractors to the extent of any loss or damage, which is insured under the OCIP.
2. Contractors/Subcontractors waive all rights of subrogation and recovery against the Owner and other Contractors/Subcontractors to the extent of any loss or damage, which is insured under the OCIP.
3. The Contractors/Subcontractors are obligated to indemnify the Owner for damages or claims not covered by the OCIP.

1.12 NO RELEASE

The provision of the OCIP, by the Owner, will in no way be interpreted as relieving the Contractors/Subcontractors of any other responsibility or liability under this agreement or any applicable law, statute, regulation, or order.

1.13 OWNER'S RIGHT TO AUDIT

The Contractor/Subcontractor will permit the Owner and/or its representative to examine and/or audit its books, records and insurance policy information. Contractor/Subcontractor will also provide any additional information to the Owner, or its appointed representatives, as may be required.

1.14 DUTIES IN THE EVENT OF A LOSS

Contractors/Subcontractors are required to report all losses, which include potential losses, promptly to, OCIP insurers and/or Program Administrator. A full description and details of the incurred loss are also required.

GENERAL CONDITIONS

The Contractor/Subcontractor shall assist the Owner, its agents, and the Program Administrator, by providing the utmost cooperation in the adjustment of claims arising out of the operations conducted under, or in connection with, the Project and shall cooperate with the Owner's insurers in claims and demands that arise out of the Work and that the insurers are called upon to adjust.

In the event of an accident, it shall be the responsibility of the employing and/or responsible Contractor/Subcontractor to see that injured workers or members of the public are provided immediate medical treatment. All appropriate medical and claim forms must be filed in accordance with the claim procedures developed for this Project by Keenan & Associates, hereinafter called "Program Administrator." This includes notification to the appropriate state authorities, if necessary.

1.15 OCCUPATIONAL SAFETY AND HEALTH COMPLIANCE

All Contractors/Subcontractors are expected to comply with all applicable local, state, and federal occupational safety and health requirements. If additional safety and health requirements are set forth in the contract specifications, all contractors shall comply with these requirements.

It is the responsibility of each Contractor/Subcontractor to maintain an environment free of recognized hazards. All Contractors/Subcontractors shall exercise reasonable care to prevent work-related injuries; property and equipment damage at the Project, as well as minimize risk to the public and third party property.

The Program Administrator shall conduct periodic loss control surveys on behalf of the District. These surveys will focus on evaluating the Contractors'/Subcontractors' efforts to minimize loss, assist in identifying loss exposures, and to recommend appropriate corrective measures. The Program Administrator is a resource to supplement the safety and loss prevention activity of Contractors/Subcontractors. Its loss control survey activities or other activities of the Program Administrator and/or OCIP insurers do not in any way relieve the Contractors/Subcontractors of their responsibilities for Project safety.

1.16 PROJECT SAFETY PROGRAM

In addition, local, state, and federal occupational safety and health laws, the following standards apply to all Enrolled and Non-Enrolled Contractors/Subcontractors.

A. Safety Orientation

1. Contractor/Subcontractor employees shall be provided with a project specific safety orientation prior the start of the project. At a minimum, the orientation will address the following items:
 - a. The District's site safety requirements.
 - b. Site specific safety hazards and protective measures for these hazards.
 - c. Emergency telephone numbers and procedures.
 - d. Local medical clinic/hospital information within the Medical Provider Network (MPN).

B. Program Management

1. Each Contractor/Subcontractors shall have the following safety programs:
 - a. Injury and Illness Prevention Plans
 - b. Hazard Communication Programs
 - c. Heat Illness Prevention Plans
2. Each Contractor/Subcontractor shall have an onsite competent person responsible for occupational safety and health.

C. Mandatory 6' Fall Protection

1. Contractor/Subcontractor employees shall be protected from fall exposures of 6 feet or greater. Activities include but are not limited to:
 - a. Steel erection
 - b. Roofing
 - c. Framing
 - d. Decking
 - e. Scaffold work
 - f. Work performed from ladders

GENERAL CONDITIONS

2. A safety monitor as means of fall protection is prohibited.
3. Ladder jacks, lean-to, and prop-scaffolds are prohibited.
4. Contractor/Subcontractors are required to provide training to their employees who might be exposed to a fall hazard prior to the exposure or upon hiring. This training shall be documented and available for review.
5. Methods of fall protection include but are not limited to the following:
 - a. Railings
 - b. Covers for Floor, Roof, and Wall Openings
 - c. Personal Fall Arrest Systems, Personal Fall Restraint Systems, and Positioning Devices
 - d. Controlled Access Zones
6. The design and construction of railings shall conform to the Cal/OSHA Construction Safety Orders.
7. The minimum parapet height allowed for fall protection is 42 inches or greater.
8. Covers used to cover floor, roof, and wall openings shall be secured in place to prevent accidental removal or displacement and shall be marked in accordance in accordance with Cal/OSHA Construction Safety Orders.
9. Covers used to cover floor and roof openings shall be capable of safely supporting the greater of 400 pounds or twice the weight of the employees, equipment and materials that may be imposed on any one square foot area of the cover at any time.
10. Controlled access zones shall be defined by a control line or other means that restricts access. Each line shall have a minimum breaking strength of 200 pounds. Signs shall be posted to warn unauthorized employees to stay out of the controlled access zone.
11. Control lines shall consist of ropes, wires, tapes, or equivalent materials. Control lines shall be erected and supported in accordance with Cal/OSHA Construction Safety Orders.

D. Site Safety

According to industry practices, it is the responsibility of contractors of all tiers to exercise reasonable care to prevent work-related injuries; property and equipment damage at the project site, as well as minimize risk to the third-party persons and property. Contractors/Subcontractors of all tiers shall be expected to comply with the following safety and loss control requirements:

1. All Subcontractors shall identify their contact person(s) to the General or Prime Contractor.
2. All Contractors/Subcontractors shall follow District procedures for dealing with the media.
3. All construction employees shall wear clothing suitable for the weather and work conditions. At a minimum, this shall be short sleeved shirts, long pants, and leather or other protective work shoes or boots.
4. Alcohol is prohibited on District property always.
5. Contractors/Subcontractors will be required to respond to all District complaints about objectionable levels of dust or noise and will be required to provide prompt and appropriate abatement.
6. Construction personnel cannot enter District grounds other than the construction site unless accompanied by District personnel, and are allowed only "incidental" contact with students. Violations of these requirements by any construction employee will result in a mandatory background check of that employee – including fingerprinting – as required by state law.
7. All prime contractors must attend the site-specific pre-construction meeting.
8. No sexual reference or preference shall be permitted on any piece of clothing or the hardhat. Any employee observed disregarding this policy shall be removed from the job site until further notice.

GENERAL CONDITIONS

9. All Contractors/Subcontractors shall control the break time activities of the employees to assure the cleanup of all soda cans, food wrappers, plastic bottles, or food containers from the break area. Such areas shall be cleaned immediately after the break and all waste placed in trash receptacles. No glass containers are permitted on the site.
10. Theft or willful damage to any property of the District, student, or other contractors will be prosecuted fully.
11. All Contractors/Subcontractors will advise non-English speaking employees in their native language either in a written format or via an interpreter of these policies.

E. Crane Safety

1. In accordance with Title 8, California Code of Regulations, section 5006.1, employers shall only permit operators who have a valid certificate (license) of competency to operate cranes. The operator shall have his license on his person, readily available for review.
2. All cranes used in lifting service, exceeding 3 tons rated capacity, and their accessory gear shall not be used until the employer has ascertained that such equipment has been certificated in accordance with Cal/OSHA as evidenced by current and valid documents. Certificates (annual and quadrennial) attesting to current compliance with testing and examination standards shall be maintained, readily available for each crane.
3. The contractor shall provide an erection plan and procedure for erection of trusses and beams over 25 feet long. The erection plan and procedure shall be prepared by a civil engineer currently registered in California. This plan and procedure shall be followed and kept available on the job site.

F. Return to Work:

1. The District and OCIP Carrier are committed to working with all Enrolled Contractors and Subcontractors to promote the successful & timely return to work of injured employees following a work-related injury. The purpose of this policy is to ensure that Enrolled Contractor/Subcontractor employees who temporarily cannot return to their normal duties due to job-related injury or illness, but can safely perform transitional duties while recovering is offered appropriate transitional duties for a limited time only.
 - a. Each Enrolled Contractor/Subcontractor will cooperate with the OCIP Carrier to facilitate the return to work of any injured employee capable of safely performing transitional duties.
 - b. When the employee is released to transitional duties, it is the Enrolled Contractor/Subcontractor's responsibility to facilitate the injured employee's return to work.
 - c. The Enrolled Contractor/Subcontractor is expected to accommodate the injured employee and facilitate the return to work.
 - d. It will be the responsibility of the Insurance Carrier's Adjuster to maintain communication with the treating physician and the Enrolled Contractor/Subcontractor to facilitate the prompt return of an employee to full work status.

1.17 OWNER'S INSURANCE OBLIGATIONS; CONTRACTORS'/SUBCONTRACTORS' OBLIGATIONS; REPRESENTATIONS, WARRANTIES AND DISCLAIMERS

ARTICLE 11 (a) Owner assumes no obligation to provide insurance other than that summarily described in these Contractual Provisions, in the Project Insurance Manual, and in the OCIP insurance policies. Contractor/Subcontractor shall review the OCIP coverages, limits of liability, and insurance policies to satisfy themselves that the coverages offered thereby meet its needs. Nothing contained herein shall be deemed to place any responsibility on Owner, and Owner disclaims any responsibility, for ensuring that the insurance provided by the OCIP is sufficient for the conduct of Contractor's/Subcontractor's business or performance of the Work, including, without limitation, the adequacy of the limits of liability provided by, and as to all other terms, conditions and exclusions of, the OCIP insurance policies. The furnishing of insurance by Owner

GENERAL CONDITIONS

through the OCIP shall in no way relieve or limit or be construed to relieve or limit Contractor/Subcontractor of any responsibility, liability or obligation imposed by the contract, the contract documents, the Project Insurance Manual, the OCIP insurance policies, or by law, including, without limitation, all indemnification obligations on the part of Contractor/Subcontractor.

ARTICLE 12 (b) By enrolling in the OCIP, Contractor/Subcontractor acknowledge that (i) the limits of liability of the OCIP insurance policies are shared by all insured parties under the OCIP for this Project; (ii) Owner is not an insurer or in the business of insurance and is not an agent, broker, partner or guarantor of Contractor/Subcontractor or any of the insurance companies providing coverage under the OCIP (the “OCIP insurers”); and (iii) Owner is not responsible for (a) the availability, adequacy, or exhaustion of the limits of the OCIP, (b) the present or future solvency of any of the OCIP insurers or (c) any claims or disputes by, between or among Owner, Contractor/Subcontractor and any of the OCIP insurers, including, without limitation, claims or disputes arising out of any the OCIP insurers’ payment or nonpayment of claims or losses, or such insurers’ contractual or extra-contractual duties, including, without limitation, defense and/or indemnity obligations. Any type of insurance coverage or limits of liability not provided by the OCIP which Contractor/Subcontractor desires for its own protection, or which is required by applicable laws or regulations, shall be its sole responsibility and expense and shall not be included in its compensation for the Work. If Contractor/Subcontractor believes that additional limits of liability beyond those provided by the OCIP would be prudent for its protection, it agrees to investigate and procure such additional limits of liability for itself at its sole cost.

ARTICLE 13 (c) By enrolling in the OCIP, Contractor/Subcontractor represents and warrants that it has had the opportunity to read and analyze (and to obtain professional assistance to read and analyze) a copy of the OCIP insurance policies and understand the contents thereof. Any reference in these contractual provisions, in the Project Insurance Manual, or elsewhere in any contract document as to amount, nature, type or extent of coverage provided under the OCIP and/or potential applicability to any potential claim or loss is for reference only and Contractor/Subcontractor represents and warrants that it has not relied upon any such reference or any other oral or written statement by or on behalf of Owner, the Project Administrator, or any of its or their agents, employees or representatives, but solely upon its own independent review and analysis of the OCIP insurance policies in formulating any understanding and/or belief as to amount, nature, type or extent of any coverage, conditions, extensions, or limits of liability provided by and as to all other terms of the OCIP insurance policies and/or their potential applicability to any claim or loss or their sufficiency for the conduct of Contractor’s/Subcontractor’s business or performance under the contract documents. To the extent that Contractor/Subcontractor deems it prudent to secure and maintain additional, supplemental, excess, or wholly independent insurance or liability associated with its Work on the Project or otherwise, it shall be responsible to do so at its sole expense.

ARTICLE 14 (d) Contractor/Subcontractor hereby releases Owner, the Program Administrator and their respective representatives, agents, directors, officers, employees, partners, shareholders, members, affiliates of every tier, successors, and assigns from any and all claims and liabilities arising out of or relating to acts, errors, omissions or negligence (i) in the design, selection, placement, adequacy, amount, limits, scope and nature of insurance coverage afforded by the OCIP, (ii) in the selection, performance and present and future solvency of the OCIP insurers, and (iii) in the implementation and administration of the OCIP. Contractor/Subcontractor shall make its own determinations regarding such matters and expressly waives all rights and benefits conferred upon it by the provisions of California Civil Code Section 1542, which provides:

ARTICLE 15

A general release does not extend to claims which the creditor did not know or suspect to exist in his or her favor

GENERAL CONDITIONS

at the time of executing the release, which if known by him or her must have materially affected his or her settlement with the debtor.”

Contractor/Subcontractor expressly acknowledges that the foregoing waiver of the provisions of Section 1542 was separately bargained for, and expressly agrees that the release provision shall be given full force and effect, including, without limitation, as to unknown or unsuspected claims, demands, liabilities and causes of action, if any may exist or arise. This release provision shall survive the completion of the Work and the expiration or other termination of the Agreement.

1.18 JOINT DEFENSE OF CLAIMS AND SUITS AGAINST MORE THAN ONE INSURED

ARTICLE 16 (a) If a claim, demand, suit, or other proceeding (“Claim”) is brought against more than one insured under the OCIP, Owner and Contractor/Subcontractor recognize the common interest of all OCIP insureds in jointly defending that Claim. To the fullest extent permitted by law, and absent a material, current, actual, unwaivable conflict of interest mandating the appointment of separate counsel under applicable law, Owner and Contractor/Subcontractor insured under the OCIP (i) shall be defended by the same counsel and by the same consultants and experts selected by Owner and/or the OCIP insurers at its or their sole discretion, regardless of whether the defense under the OCIP is provided subject to a reservation of rights issued by any OCIP insurer, and (ii) waive their respective rights to independent counsel as to any and all such Claims. This waiver is deemed to be continuing. Contractor/Subcontractor agrees to execute such other documents as are required to effectuate this waiver and fulfill the purpose of this Section 1.18.

ARTICLE 17 (b) In defense of Claims arising under the OCIP, information shared with counsel engaged to defend the insureds (“Defense Counsel”) will be protected from disclosure and shall remain privileged even after the termination of the OCIP and/or the completion of the Project. Contractor/Subcontractor agrees not to disclose to any person or entity, other than to Owner and to Defense Counsel, any confidential information obtained in the defense or pursuit of Claims covered, or potentially covered, under the OCIP. Any such confidential information shall only be used in matters that arise directly pursuant to such OCIP Claims. However, disclosures of such confidential information may be made (i) upon written approval from Defense Counsel or (ii) where required by court order or by applicable law.

ARTICLE 18 (c) Nothing in this Section 1.18 shall preclude Contractor/Subcontractors from engaging counsel of its choice, at its sole expense, to associate in the defense of any such Claim.

1.19 DUTY OF CARE

Nothing contained in the OCIP insurance policies, the contract, these contractual provisions, any other contract document, or the Project Insurance Manual shall relieve Contractor/Subcontractor of its obligations to exercise due care in the performance of its duties in connection with the Work and to complete the Work in strict compliance with the contract documents.

NOTE: THE OWNER AND PROGRAM ADMINISTRATOR MUST APPROVE CHANGES TO ANY OCIP REQUIREMENT OR PROCEDURE. NO CONTRACTOR OR SUBCONTRACTOR HAS THE AUTHORITY TO AMEND THE OCIP REQUIREMENTS.

GENERAL CONDITIONS

EXHIBIT A

OCIP Contract Enrollment Form

Change Order Short term / T & M

Form must be completed by all Contractors/Subcontractors of all tiers for all initial/new contracts and any additional contracts and/or change orders for each project. If using subcontractors, you may use **OCIP Tools Online** to report each subcontractor or complete the "Expected Subcontractors" detail on the next page. **Parent Contractor is responsible for 100% subcontractor compliance with OCIP requirements as set forth in their contract and the SEWUP Project Insurance Manual.**

District: _____ Project: _____

CONTRACTOR DETAILS

Contractor Legal Name: _____ Corporation Sole Proprietor Partnership Joint Venture LLC

DBA or Subsidiary: _____ FEIN#: _____ Contractor License #: _____

Business Address (Address as listed on Insureds Certificate): _____

Office Address (If Different from Business Address): _____

| | Contact Name | Phone | Fax | Email |
|---------------------------|--------------|-------|-------|-------|
| Main Enrollment Contact | _____ | _____ | _____ | _____ |
| Insurance Contact | _____ | _____ | _____ | _____ |
| Payroll Contact | _____ | _____ | _____ | _____ |
| Site Contact/Project Mgr. | _____ | _____ | _____ | _____ |

CONTRACT DETAILS

General/Prime Contractor Subcontractor Tier Subcontractor Temp. Labor, Time & Material, or Other: _____ Bid Package #: _____

Awarding Contractor: _____ Prime Contractor: _____

Contract Value: _____ Self Performed Work: _____ % \$ _____ Estimated Payroll: _____

Est. # of Subcontractors: _____ Subcontracted Work: _____ % \$ _____

If using subcontractors, please be sure to complete subcontractor information on next page

Contract Award Date: _____ Est. Start Date: _____ Est. Completion Date: _____

Description of Work: _____

Off-Site Work Performed? YES NO If Yes, Description of Off-site work: _____

CONTRACTORS CURRENT INSURANCE INFORMATION

Insurance Broker or Agency: _____ Agent/Broker Contact: _____

Phone: _____ Fax: _____ Email: _____

WORKERS COMPENSATION INSURANCE

Name of Insurer: _____ WC Policy #: _____ Bureau ID: _____

Effective From: _____ To: _____ Deductible / SIR: _____ Anniversary Rating Date: _____

WORKERS COMPENSATION DETAILS (Estimated Project Site Payroll Only)

| WC Class Code | WC Class Code Description | Rate | Est. Man Hours | Est. Payroll | Premium | |
|---|---------------------------|------|----------------|--|-------------------|------|
| | | \$ | | \$ | \$ 0 | |
| | | \$ | | \$ | \$ 0 | |
| | | \$ | | \$ | \$ 0 | |
| | | \$ | | \$ | \$ 0 | |
| Was Experience Modifier included in your above WC Class rate(s)? <input type="checkbox"/> YES <input type="checkbox"/> NO | | | | Subtotals: | \$ | \$ 0 |
| | | | | Experience Modifier : <u> 1 </u> | Modified Premium: | \$ 0 |
| | | | | Plus/Minus Rate Deviations or Premium credits: | | \$ 0 |
| | | | | (Cost A) Total Workers' Compensation Cost: | | \$ 0 |

Attach Copies of Work Comp rate pages with enrollment form.

Keenan & Associates, 2355 Crenshaw Blvd., Ste. #200, Torrance, CA 90501, Attn: SEWUP, Phone (310) 212-0363, Fax (310) 787-8838, Email SEWUP@keenan.com License # 0451271

GENERAL CONDITIONS



OCIP Contract Enrollment Form

GENERAL & EXCESS LIABILITY INSURANCE

General Liability Insurer _____ General Liability Policy #: _____
 General Liability Effective From: _____ To: _____ General Liability Deductible: _____ or, Retention: _____
 Excess Liability Insurer: _____ Excess Liability Policy #: _____ Effective From: _____ To: _____

GENERAL & EXCESS LIABILITY INSURANCE DETAILS (Include Values related to this project contract)

| Coverage | Classification Description | Based on Payroll, Receipts or Other | Rate | Per \$100 / \$1000 or Other | Total Value (Payroll, receipts, or Other) | Liability Premium |
|---------------------------|----------------------------|-------------------------------------|------|-----------------------------|---|-------------------|
| General Liability | 1. | | \$ | \$ | \$ | \$ |
| | 2. | | \$ | \$ | \$ | \$ |
| Excess/Umbrella Liability | | | \$ | \$ | \$ | \$ |
| | | | | | (Cost B) Total Liability Cost: | \$ |

Attach copies of GL and XL declarations and rate pages with enrollment form.

TOTAL INSURANCE COST

(Cost C) Margin Factor (Apply your Mark-Up Against Current Cost): \$ _____
 (Cost A + B + C) Total Insurance Cost: \$ _____

EXPECTED SUBCONTRACTORS (If needed, please attach additional sheets including all information requested below.)

Company Name: _____ Contractor License #: _____ Est. Contract Value: _____
 Scope of Work: _____ Est. Start Date: _____ Est. Completion Date: _____
 Contact: _____ Phone: _____ Fax: _____ Email: _____

Company Name: _____ Contractor License #: _____ Est. Contract Value: _____
 Scope of Work: _____ Est. Start Date: _____ Est. Completion Date: _____
 Contact: _____ Phone: _____ Fax: _____ Email: _____

Company Name: _____ Contractor License #: _____ Est. Contract Value: _____
 Scope of Work: _____ Est. Start Date: _____ Est. Completion Date: _____
 Contact: _____ Phone: _____ Fax: _____ Email: _____

Company Name: _____ Contractor License #: _____ Est. Contract Value: _____
 Scope of Work: _____ Est. Start Date: _____ Est. Completion Date: _____
 Contact: _____ Phone: _____ Fax: _____ Email: _____

Company Name: _____ Contractor License #: _____ Est. Contract Value: _____
 Scope of Work: _____ Est. Start Date: _____ Est. Completion Date: _____
 Contact: _____ Phone: _____ Fax: _____ Email: _____

I DECLARE UNDER PENALTY OF PERJURY, UNDER THE LAWS OF THE STATE OF CALIFORNIA, THAT:

1. THE INFORMATION CONTAINED IN THIS DOCUMENT IS TRUE AND CORRECT.
2. I HEREBY UNDERSTAND THAT ENROLLMENT IS CONTINGENT UPON RECEIPT AND ACCEPTANCE OF THIS FORM AND ANY APPLICABLE CERTIFICATES OF INSURANCE. SHOULD I SUBMIT AN INCOMPLETE FORM, KEENAN'S SEWUP DEPARTMENT WILL CONTACT ME AND MY FIRM WILL NOT BE ENROLLED UNTIL I PROVIDE ALL NECESSARY INFORMATION IN ITS ENTIRETY.
3. I HAVE READ AND UNDERSTAND THE INFORMATION CONTAINED IN THE BID SPECIFICATIONS REGARDING THE INSURANCE COVERAGES PROVIDED THROUGH THE OCIP. MY FIRM UNDERSTANDS AND ACCEPTS THE INSURANCE PROVIDED UNDER THIS OCIP.
4. MY FIRM AGREES TO COMPLY WITH THE REQUIREMENTS OF THE OCIP AND FOLLOW THE ADMINISTRATIVE PROCEDURES AS OUTLINED IN THE BID SPECIFICATIONS

Signature: _____ Title: _____ Date: _____

Keenan & Associates, 2355 Crenshaw Blvd., Ste. #200, Torrance, CA 90501, Attn: SEWUP, Phone (310) 212-0363, Fax (310) 787-8838, Email SEWUP@keenan.com License # 0451271

GENERAL CONDITIONS

ARTICLE 19 **EXHIBIT B**

| KNOWN OCIP POLICY EXCLUSIONS | |
|--|--|
| Workers Compensation | General Liability |
| Bodily Injury Outside US or Canada | Aircraft, Auto or Watercraft |
| Bodily Injury To Any Member of Flying Crew | Asbestos |
| Bodily Injury To Person Subject To Federal Workers' Compensation | Certain Exclusions To Medical Payments Coverage |
| Bodily Injury To Person Subject To Occupational Disease Laws | Certain Exclusions To Personal and Advertising Injury Liability |
| Contractual Liability | Certified Acts of Terrorism |
| Employees Knowingly Employed Illegally | Contractual Liability (Limited Coverage Provided) |
| Employment Related Practices | Employers Liability |
| Intentional or Aggravated Bodily Injury | Employment Related Practices |
| Obligations Imposed By Disability Benefits or Any Similar Law | Expected or Intended Injury |
| Obligations Imposed By Occupational Disease Laws | Exterior Insulation and Finish Systems (EIFS) "Subject to Installation Requirements" |
| Obligations Imposed By Unemployment Compensation Laws | Fungi Or Bacteria |
| Obligations Imposed By Workers' Compensation Laws | Lead |
| State or Federal Law Violation Fines, Penalties | Mobile Equipment |
| Builders Risk | Nuclear |
| Asbestos | Personal and Advertising Bodily Injury |
| Certain Offsite Property | Pollution |
| Certain Release, Discharge, Escape, or Dispersal Of Contaminants | Prior Continuous, or Progressively Deteriorating Injury or Damage |
| Certified Acts of Terrorism (Can be added) | Professional Liability |
| Cessation of Work | Recall of Products, Work Or Impaired Property |
| Contractor's Tools, Machinery, Plans, Equipment | Silica or Silica Mixed Dust |
| Cost of Making Good | Violation of Statutes Governing Collecting, Transmitting Information |
| Damage To Existing Property (Can be added) | Violation of Statutes Governing Email, Fax, Phone Calls |
| Damage While Testing Prototype or Used Machinery/Equipment | War |
| Damages, Fines, Penalties At Government Agency or Court Order | Workers Compensation and Similar Laws |
| Disappearance or When Revealed By Inventory Shortage Alone | Contractors Pollution Liability |
| Earth Movement (Optional sublimits can be added) | Auto, Aircraft, Vessel Or Rolling Stock |
| Electrical, Magnetic, or Errors Related To Electronic Records | Claims Between Certain Insured's |
| Financial Accounts, Instruments, Stamps, Deeds, Precious Material | Contractual Liability |
| Flood (Optional sublimits can be added) | Damage To Property |
| Foreign Terrorism | Disposal Sites |
| Infidelity, Dishonesty, Fraudulent Activity Of Insured | Employment Related Practices |
| Land, Values of Land, Cut, & Fill etc. Prior to Project Commencement | Fines, Penalties, and Treble Damages |
| Loss Under Any Manufacturer or Supplier Guarantee/Warranty | Hazardous Materials Facility |
| Normal Subsidence | Intentional Acts |
| Nuclear | Nuclear |
| Offshore Or Barrier Island Property | Other Entities |
| Property That Stores, Processes, or Handles Radioactive Materials | Pre-Existing Conditions |
| Rolling Stock, Aircraft, Watercraft | Products |
| Software Loss, unless results from an Open Peril | Related Entities and Individuals |
| Standing Timber, Growing Crops, Animals | Transportation Of Pollutants |
| Vehicles or Equipment Licensed For Highway Use | War |
| War and Military Action | Workers Compensation and Similar Laws |

ARTICLE 20

EXHIBIT C

GENERAL CONDITIONS

PROTECTIVE SAFEGUARDS

APPLICABLE TO 'WOOD FRAME' PROJECTS ONLY:

The Builders Risk Policy will not pay for LOSS caused by or resulting from exposures, if the applicable protective safeguards are not maintained during the Builders Risk Policy term of INSURED PROJECT.

As a condition precedent to fire, theft, vandalism, and malicious mischief coverage provided by the Builders Risk Policy, the following protective safeguards will be maintained at every INSURED PROJECT site of Wood Frame construction insured by the Builders Risk Policy.

1. **Fencing - The entire INSURED PROJECT** site shall be surrounded with a six foot chain link fence suitably anchored in the ground and placed a reasonable distance from the insured property. Gates through the chain link fence shall be securely locked during non-working hours.
2. **Lighting - The entire INSURED PROJECT** site shall be illuminated from sunset to sunrise, each day.

GENERAL CONDITIONS

EXHIBIT D

Save Form
Print Form
Submit Form



PROJECT SITE MONTHLY PAYROLL REPORT
Due on the 10th of each month (for previous month labor)

District Name: _____ Bid Pkg. #: _____
 Project Name: _____ REPORT # _____
(For your Firm's use)
 Reporting Month: _____ *Example Feb-2006*
 Company Name: _____ Db Name: _____
 Under Contract With: _____ SEWUP Site Code*: _____

*SEWUP Site Code can be found on Accident Claim Reporting Guide or Certificate of Insurance issued for this project, under the Description of Operations section.

| Workers' Compensation Class Code | Description | On-site man hours | Payroll* |
|----------------------------------|-------------|-------------------|----------|
| | | | |
| | | | |
| | | | |
| | | | |
| | | | |
| | | | |
| | | | |
| | | | |
| | | | |
| TOTAL | | 0.00 | \$0.00 |

Is this your final payroll report? YES NO

If Yes, submit final report with Contract Completion Notice. If this is not your final report, payroll must be submitted each month until contract work is complete. If there is no on site labor, 0 hours must be reported and submitted.

I CERTIFY THAT THE INFORMATION REPORTED ABOVE IS TRUE AND ACCURATE. NOT REPORTING ACCURATE PAYROLL INFORMATION COULD AFFECT YOUR EXMOD - EXPERIENCE MODIFICATION RATING WITH THE WORKERS' COMPENSATION INSURANCE RATING BUREAU (WCIRB).

Signature: _____ Title: _____

Print Name: _____ Date: _____

*Only report payroll for work performed on-site. Do not include overtime wage rates, use straight time wage rates only, i.e., employee earns \$20/hr. and works 10 hours in one day, you would report \$200.00 (\$20.00 x 10). Payroll/remuneration that is taxable to employee and paid by your company, is reported to WCIRB.

Keenan & Associates
SEWUP Department
2355 Crenshaw Blvd., Ste. #200,
Torrance, CA 90501
Phone (310) 212-3344, Fax (310) 787-8838

[SUBMIT: SEWUP@KEENAN.COM](mailto:SUBMIT:SEWUP@KEENAN.COM)



v 090314

GENERAL CONDITIONS

EXHIBIT E

| | |
|---|--|
| <input type="button" value="Save Form"/> | <input type="button" value="Submit Form"/> |
|  Sewup@keenan.com | |
| Contractor's Completion Notice | |
| District Name _____ | |
| Project Name _____ | |
| IMPORTANT NOTIFICATION – PLEASE READ | |
| <i>Contractor and Subcontractor agrees to complete this form and return to Keenan & Associates upon completion or termination of work activities under this contract. Please include, with this form, any supporting documents for final contract value (if different from initial contract value).</i> | |
| Contractor/Subcontractor Legal Name: _____ | |
| Contractor/Subcontractor dba Name: _____ | |
| Address: _____ | |
| Site Location Code/ Contract Number: _____ | |
| Initial Contract Value: \$ _____ | Final Contract Value: \$ _____ |
| Start Date on Site: _____ | Last Day on Site*: _____ |
| <i>*This would include work performed on final closeout or punch-list items and should not include warranty work.</i> | |
| Parent Contractor (Company Name): _____ | |
| Parent Contractor Contact Name (Print): _____ | Title: _____ |
| Signature (Parent Contractor): _____ | Date: _____ |
| ----- | |
| Contractor/Subcontractor Contact Name (Print): _____ | Title: _____ |
| Signature (Contractor/Subcontractor): _____ | Date: _____ |
| ----- | |
| <small>Keenan & Associates SEWUP Department 2355 Crenshaw Blvd., Ste. #200, Phone (310) 212-3344, Fax (310) 767-8838 Sewup@keenan.com www.sewup.org License No. 0451271</small> | |
|  | |

GENERAL CONDITIONS

PERFORMANCE AND PAYMENT BONDS

11.1 BOND REQUIREMENTS

ARTICLE 22 Unless otherwise specified in the Supplemental Conditions, prior to commencing any portion of the Work, the Contractor shall furnish separate Payment and Performance Bonds for its portion of the Work which shall cover 100% faithful performance of and payment of all obligations arising under the Contract Documents and/or guaranteeing the payment in full of all claims for labor performed and materials supplied for the Work. All bonds shall be provided by a corporate Surety authorized and admitted to transact business in California as sureties.

ARTICLE 23 To the extent, if any, that the Contract Price is increased in accordance with the Contract Documents, the Contractor shall, upon request of the District, cause the amount of the bonds to be increased accordingly and shall promptly deliver satisfactory evidence of such increase to the District. To the extent available, the bonds shall further provide that no change or alteration of the Contract Documents (including, without limitation, an increase in the Contract Price, as referred to above), extensions of time, or modifications of the time, terms, or conditions of payment to the Contractor will release the Surety. If the Contractor fails to furnish the required bonds, the District may terminate the Contract for cause.

11.1.1 Surety Qualification

ARTICLE 24 Only bonds executed by admitted Surety insurers as defined in Code of Civil Procedure § 995.120 shall be accepted. Surety must be a California-admitted Surety and listed by the U.S. Treasury with a bonding capacity in excess of the Project cost.

11.1.2 Alternate Surety Qualifications

ARTICLE 25 If a California-admitted Surety insurer issuing bonds does not meet these requirements, the insurer will be considered qualified if it is in conformance with § 995.660 of the California Code of Civil Procedure and proof of such is provided to the District.

GENERAL CONDITIONS

12

UNCOVERING AND CORRECTION OF WORK

12.1 COMPLIANCE WITH TITLE 24 INSTALLATION REQUIREMENTS

Contractor is aware of the requirements governing Contractor's Work under title 24 Section 4-343 which provides, in pertinent part:

4-343. Duties of the Contractor.

(a) **Responsibilities.** It is the duty of the contractor to complete the Work covered by his or her contract in accordance with the approved Plans and Specifications therefore. The contractor in no way is relieved of any responsibility by the activities of the architect, engineer, Inspector or DSA in the performance of such duties.

(b) **Performance of the Work.** The contractor shall carefully study the approved Plans and Specifications and shall plan a schedule of operations well ahead of time. If at any time it is discovered that Work is being done which is not in accordance with the approved Plans and Specifications, the contractor shall correct the Work immediately. All inconsistencies or items which appear to be in error in the Plans and Specifications shall be promptly called to the attention of the architect or registered engineer, through the Inspector, for interpretation or correction. In no case, however, shall the instruction of the architect or registered engineer be construed to cause Work to be done which is not in conformity with the approved Plans, Specifications, and Change Orders. The contractor must notify the Project Inspector, in advance, of the commencement of construction of each and every aspect of the Work.

12.1.1 Issuance of Notices of Non-Compliance

The Inspector may issue a Notice of Non-Compliance on the Project indicating deviation from Plans and Specifications. It is Contractor's responsibility to correct all deviations from the approved Plans and Specifications unless the District has issued an Immediate Change Directive. In such case, the Contractor shall proceed with the Work with the understandings of the District as set forth in the WD and as specifically noted in Article 7.3.

12.2 SPECIAL NOTICE OF AMERICAN'S WITH DISABILITIES ACT

Some of the requirements in the Plans and Specifications are meant to comply with the Americans with Disabilities Act ("ADA"). The requirements of the ADA are technical in nature and may appear to be minor in nature (i.e. whether a walkway or ramp has a 2% cross-slope). Contractor is warned that even the slightest deviation from the specific requirements from the ADA is considered a Civil Rights violation and subjects the District to fines of three times actual damages sustained by a handicap individual or up to \$4,000 per violation and attorney's fees required to enforce the ADA violation. As a result of the significant liability and exposure associated with ADA aspects of the Contract, Contractor shall take special care to meet all ADA requirements detailed in the Plans and Specifications. Failure to comply with ADA rules that results in a Notice of Non-Compliance shall be repaired to meet ADA requirements promptly. In addition, any ADA violations that are not identified by Inspector or Architect that are later identified shall be repaired and charged back to the Contractor through a Deductive Change Order.

GENERAL CONDITIONS

12.2.1 Indemnification of ADA Claims

Contractor shall indemnify, hold harmless and defend the District from ADA claims arising from the failure to comply with the Plans and Specifications. Further, any withholdings for ADA violations under Article 9.6 shall include potential redesign costs and an accelerated repair costs due to the potential for ADA claims arising from DSA posting of ADA violations on the Project.

12.3 UNCOVERING OF WORK

12.3.1 Uncovering Work for Required Inspections

Work shall not be covered without the Inspector's review and the Architect's knowledge that the Work conforms with the requirements of the approved Plans and Specifications (except in the case of an ICD under Article 7.3). Inspector must be timely notified of inspections and of new areas so Work can be inspected at least 48 hours before opening a new area (For example, see DSA Form 156 for Commencement/Completion of Work Notification which requires "at least 48 hour" advance notification of a new area). An Inspector must comply with DSA protocols for signing each category or phase of Work under DSA Form 152 (in compliance with the Form 152 Manual) or a Notice of Deviation (DSA Form 154) will be issued requiring the Work that was not inspected be uncovered for inspection. Thus, if a portion of the Work is covered without inspection or Architect approval, is subject to a Notice of Non-Compliance for being undertaken without inspection, or otherwise not in compliance with the Contract Documents, after issuance of a Written Notice of Non-Compliance (Form 154) or a written notice to uncover Work, Contractor shall promptly uncover all Work (which includes furnishing all necessary facilities, labor, and material) for the Inspector's or the Architect's observation and such Work shall be replaced at the Contractor's expense without change in the Contract Sum or Time.

12.3.2 Costs for Inspections Not Required

If a portion of the Work has been covered is believed to be Non-Conforming to the Plans and Specifications, even if the Form 152 for the category of Work has been signed by the Inspector, the Inspector or the Architect may request to see such Work, and it shall be promptly uncovered by the Contractor. If such Work is in accordance with the Contract Documents, costs of uncover and replacement shall, by appropriate Change Order and shall, be charged to the District. If such Work is not in accordance with Contract Documents, the Contractor shall be responsible for all costs to uncover the Work, delays incurred to uncover the Work, and Contractor shall pay all costs to correct the Non-Conforming construction condition unless the condition was caused by the District or a separate contractor, in which event the District shall be responsible for payment of such costs to the Contractor.

12.4 CORRECTION OF WORK

12.4.1 Correction of Rejected Work

The Contractor shall promptly correct the Work rejected by the Inspector or the District upon recommendation of the Architect as failing to conform to the requirements of the Contract Documents, whether observed before or after Completion and whether or not Fabricated, installed, or completed. The Contractor shall bear costs of correcting the rejected Work, including cost for delays that may be incurred by Contractor or Subcontractors, the cost for additional testing, inspections, and compensation for the Inspector's or the Architect's services and expenses made necessary thereby (including costs for preparing a CCD, DSA CCD review fees, and additional inspection and special inspection costs).

GENERAL CONDITIONS

12.4.2 One-Year Warranty Corrections

If, within one (1) year after the date of Completion of the Work or a designated portion thereof, or after the date for commencement of warranties established under Article 9.9.1, or by the terms of an applicable special warranty required by the Contract Documents, any of the Work is found to be not in accordance with the requirements of the Contract Documents, the Contractor shall correct it promptly after receipt of written notice from the District to do so unless the District has previously given the Contractor a written acceptance of such condition. This period of one (1) year shall be extended with respect to portions of the Work first performed after Completion by the period of time between Completion and the actual performance of the Work. This obligation under this Article 12.4.2 shall survive acceptance of the Work under the Contract and termination of the Contract. The District shall give such notice promptly after discovery of the condition.

12.4.3 District's Rights if Contractor Fails to Correct

If the Contractor fails to correct nonconforming Work within a reasonable time, the District may correct the Work and seek a Deductive Change Order, pursuant to Article 9.6 or Article 2.2.

GENERAL CONDITIONS

13 MISCELLANEOUS PROVISIONS

13.1 GOVERNING LAW

The Contract shall be governed by the law of the place where the Project is located.

13.2 SUCCESSORS AND ASSIGNS

The District and the Contractor respectively bind themselves, their partners, successors, assigns, and legal representatives to the other party hereto and to partners, successors, assigns, and legal representatives of such other party in respect to covenants, agreements, and obligations contained in the Contract Documents. Neither party to the Contract shall assign the Contract as a whole without written consent of the other. If either party attempts to make such an assignment without such consent, that party shall nevertheless remain legally responsible for all obligations under the Contract.

13.3 WRITTEN NOTICE

In the absence of specific notice requirements in the Contract Documents, written notice shall be deemed to have been duly served if delivered in person to the individual, member of the firm or entity, or to an officer of the corporation for which it was intended, or if delivered at or sent by registered or certified mail to the last business address known to the party giving notice.

13.4 RIGHTS AND REMEDIES

13.4.1 Duties and Obligations Cumulative

Duties and obligations imposed by the Contract Documents and rights and remedies available thereunder shall be in addition to and not a limitation of duties, obligations, rights, and remedies otherwise imposed or available by law.

13.4.2 No Waiver

No action or failure to act by the Inspector, the District, or the Architect shall constitute a waiver of a right or duty afforded them under the Contract Documents, nor shall such action or failure to act constitute approval of or acquiescence in a breach thereunder, except as may be specifically agreed in writing.

13.5 TESTS AND INSPECTIONS

13.5.1 Compliance

Tests, inspections, and approvals of portions of the Work required by the Contract Documents will comply with Division 1, Title 24, and with all other laws, ordinances, rules, regulations, or orders of public authorities having jurisdiction.

13.5.2 Independent Testing Laboratory

GENERAL CONDITIONS

The District will select and pay an independent testing laboratory to conduct all tests and inspections. Selection of the materials required to be tested shall be made by the laboratory or the District's representative and not by the Contractor. See Articles ARTICLE 1 and 4.3.6 regarding costs or expenses of inspection or testing outside of the Project Site.

13.5.3 Advance Notice to Inspector

The Contractor shall notify the Inspector a sufficient time in advance of its readiness for required observation or inspection so that the Inspector may arrange for same. The Contractor shall notify the Inspector a sufficient time in advance of the manufacture of material to be supplied under the Contract Documents which must, by terms of the Contract Documents, be tested in order that the Inspector may arrange for the testing of the material at the source of supply.

13.5.4 Testing Off-Site

Any material shipped by the Contractor from the source of supply, prior to having satisfactorily passed such testing and inspection or prior to the receipt of notice from said Inspector that such testing and inspection will not be required, shall not be incorporated in the Work.

13.5.5 Additional Testing or Inspection

If the Inspector, the Architect, the District, or public authority having jurisdiction determines that portions of the Work require additional testing, inspection, or approval not included under Article 13.5.1, the Inspector will, upon written authorization from the District, make arrangements for such additional testing, inspection, or approval. The District shall bear such costs except as provided in Articles 13.5.6 and 13.5.7.

13.5.6 Costs for Retesting

If such procedures for testing, inspection, or approval under Articles 13.5.1 and 13.5.2 reveal failure of the portions of the Work to comply with requirements established by the Contract Documents, the Contractor shall bear all costs arising from such failure, including those of re-testing, re-inspection, or re-approval, including, but not limited to, compensation for the Architect's services and expenses. Any such costs shall be paid by the District, invoiced to the Contractor, and deducted from the next Progress Payment.

13.5.7 Costs for Premature Test

In the event the Contractor requests any test or inspection for the Project and is not completely ready for the inspection, the Contractor shall be invoiced by the District for all costs and expenses resulting from that testing or inspection, including, but not limited to, the Inspector's and Architect's fees and expenses, and the amount of the invoice shall be deducted from the next Progress Payment.

13.6 TRENCH EXCAVATION

13.6.1 Trenches Greater Than Five Feet

Pursuant to Labor Code section 6705, if the Contract Price exceeds \$25,000 and involves the excavation of any trench or trenches five (5) feet or more in depth, the Contractor shall, in advance of

GENERAL CONDITIONS

excavation, submit to the District or a registered civil or structural engineer employed by the District or Architect, a detailed plan showing the design of shoring for protection from the hazard of caving ground during the excavation of such trench or trenches.

13.6.2 Excavation Safety

If such plan varies from the Shoring System Standards established by the Construction Safety Orders, the plan shall be prepared by a registered civil or structural engineer, but in no case shall such plan be less effective than that required by the Construction Safety Orders. No excavation of such trench or trenches shall be commenced until said plan has been accepted by the District or by the person to whom authority to accept has been delegated by the District.

13.6.3 No Tort Liability of District

Pursuant to Labor Code § 6705, nothing in this Article shall impose tort liability upon the District or any of its employees.

13.6.4 No Excavation without Permits

The Contractor shall not commence any excavation Work until it has secured all necessary permits including the required CAL OSHA excavation/shoring permit. Any permits shall be prominently displayed on the Site prior to the commencement of any excavation.

13.7 WAGE RATES, TRAVEL, AND SUBSISTENCE

13.7.1 Wage Rates

Pursuant to the provisions of Article 2 (commencing at § 1720), Chapter 1, Part 7, Division 2, of the Labor Code, the District has obtained the general prevailing rate of per diem wages and the general prevailing rate for holiday and overtime work in the locality in which this public works project is to be performed for each craft, classification, or type of worker needed for this Project from the Director of the Department of Industrial Relations (“Director”). These rates are on file at the administrative office of the District and are also available from the Director of the Department of Industrial Relations. Copies will be made available to any interested party on request. The Contractor shall post a copy of such wage rates at appropriate, conspicuous, weatherproof points at the Site.

Any worker employed to perform Work on the Project, but such Work is not covered by any classification listed in the published general prevailing wage rate determinations or per diem wages determined by the Director of the Department of Industrial Relations, shall be paid not less than the minimum rate of wages specified therein for the classification which most nearly corresponds to the employment of such person in such classification.

13.7.2 Holiday and Overtime Pay

Holiday and overtime work, when permitted by law, shall be paid for at the rate set forth in the prevailing wage rate determinations issued by the Director of the Department of Industrial Relations or at least one and one-half (1½) times the specified basic rate of per diem wages, plus employer payments, unless otherwise specified in the Contract Documents or authorized by law.

13.7.3 Wage Rates Not Affected by Subcontracts

GENERAL CONDITIONS

The Contractor shall pay and shall cause to be paid each worker engaged in the execution of the Work on the Project not less than the general prevailing rate of per diem wages determined by the Director, regardless of any contractual relationship which may be alleged to exist between the Contractor or any Subcontractor and such workers.

13.7.4 Per Diem Wages

The Contractor shall pay and shall cause to be paid to each worker needed to execute the Work on the Project per diem wages including, but not limited to, employer payments for health and welfare, pensions, vacation, travel time and subsistence pay as provided for in Labor Code §1773.1.

13.7.5 Forfeiture and Payments

Pursuant to Labor Code §1775, the Contractor shall forfeit to the District, not more than Two Hundred Dollars (\$200.00) for each calendar day, or portion thereof, for each worker paid less than the prevailing wages rates as determined by the Director of the Department of Industrial Relations, for the work or craft in which the worker is employed for any Work done under the Agreement by the Contractor or by any Subcontractor under it. The amount of the penalty shall be determined by the Labor Commissioner and shall be based on consideration of: (1) whether the Contractor or Subcontractor's failure to pay the correct rate of per diem wages was a good faith mistake and, if so, the error was promptly and voluntarily correct upon being brought to the attention of the Contractor or Subcontractor; and (2) whether the Contractor or Subcontractor has a prior record of failing to meet its prevailing wage obligations.

13.7.6 Monitoring and Enforcement by Labor Commissioner

Monitoring and enforcement of the prevailing wage laws and related requirements will be performed by the Labor Commissioner/ Department of Labor Standards Enforcement (DLSE). The Contractor and all subcontractors shall be required to furnish, at least monthly, certified payroll records directly to the Labor Commissioner in accordance with Labor Code section 1771.4. All payroll records shall be furnished in a format required by the Labor Commissioner. The Contractor and all subcontractors must sign up for, and utilize, the Labor Commissioner's electronic certified payroll records submission system. The District will have direct and immediate access to all CPRs for the Project that are submitted through the Labor Commissioner's system. The District can use this information for any appropriate purpose, including monitoring compliance, identifying suspected violations, and responding to Public Records Act requests.

The Labor Commissioner/ DLSE may conduct various compliance monitoring and enforcement activities including, but not limited to, confirming the accuracy of payroll records, conducting worker interviews, conducting audits, requiring submission of itemized statements prepared in accordance with Labor Code section 226, and conducting random in-person inspections of the Project site ("On-Site Visits"). On-Site Visits may include inspections of records, inspections of the Work site and observation of work activities, interviews of workers and others involved with the Project, and any other activities deemed necessary by the Labor Commissioner/DLSE to ensure compliance with prevailing wage requirements. The Labor Commissioner/DLSE shall have free access to any construction site or other place of labor and may obtain any information or statistics pertaining to the lawful duties of the Labor Commissioner/DLSE.

Any lawful activities conducted or any requests made by the Labor Commissioner/DLSE shall not be the basis for any delays, claims, costs, damages or liability of any kind against the District by the Contractor. Contractor and all subcontractors shall cooperate and comply with any lawful requests by

GENERAL CONDITIONS

the Labor Commissioner/ DLSE. The failure of the Labor Commissioner, DLSE, or any other entity related to the Department of Industrial Relations to comply with any requirement imposed by the California Code of Regulations, Title 8, Chapter 8 shall not of itself constitute a defense to the failure to pay prevailing wages or to comply with any other obligation imposed by Division 2, Part 7, Chapter 1 of the Labor Code.

Prior to commencing any Work on the Project, the Contractor shall post the required notice/poster required under the California Code of Regulations and Labor Code section 1771.4 in both English and Spanish at a conspicuous, weatherproof area at the Project site. The required notice/poster is available on the Labor Commissioner's website.

13.8 RECORDS OF WAGES PAID

13.8.1.1.1 Payroll Records

- a. Pursuant to §1776 of the Labor Code, the Contractor and each Subcontractor shall keep an accurate payroll record showing the name, address, social security number, work classification and straight time and overtime hours worked each day and week, and the actual per diem wages paid to each journeyman, apprentice, worker or other employee employed by him or her in connection with the Project.

All payroll records as specified in Labor Code §1776 of the Contractor and all Subcontractors shall be certified and furnished directly to the Labor Commissioner in accordance with Labor Code §1771.4(a)(3) on a monthly basis (or more frequently if required by the District or the Labor Commissioner) and in a format prescribed by the Labor Commissioner. Payroll records as specified in Labor Code §1776 shall be certified and submitted to the District with each application for payment. All payroll records shall be available for inspection at all reasonable hours at the principal office of the Contractor on the following basis:

13.8.1.1.1.1 A certified copy of an employee's payroll record shall be made available for inspection or furnished to the employee or his or her authorized representative on request.

13.8.1.1.1.2 A certified copy of all payroll records shall be made available for inspection or furnished upon request to a representative of District, the Division of Labor Standards Enforcement or the Division of Apprenticeship Standards of the Department of Industrial Relations.

13.8.1.1.1.3 A certified copy of all payroll records shall be made available upon request by the public for inspection or for copies thereof. However, a request by the public shall be made through the District, the Division of Apprenticeship Standards or the Division of Labor Standards Enforcement. If the requested payroll records have not been provided pursuant to Paragraph (2) above, the requesting party shall, prior to being provided the records, reimburse the costs, according to law for the preparation by the Contractor, Subcontractor(s), and the entity through which the request was made. The public shall not be given access to such records at the principal office of the Contractor.

- 13.8.1.1.2 The certified payroll records shall be on forms provided by the Division of Labor Standards Enforcement or shall contain the same information as the forms provided by the Division of Labor Standards Enforcement.

GENERAL CONDITIONS

- 13.8.1.1.3 The Contractor or Subcontractor(s) shall file a certified copy of all payroll records with the entity that requested such records within 10 calendar days after receipt of a written request.
- 13.8.1.1.4 Any copy of records made available for inspection as copies and furnished upon request to the public or any public agency by the District, the Division of Apprenticeship Standards or the Division of Labor Standards Enforcement shall be marked or obliterated to prevent disclosure of an individual's name, address and social security number. The name and address of the Contractor awarded the Contract or the Subcontractor(s) performing the Contract shall not be marked or obliterated. Any copy of records made available for inspection by, or furnished to, a joint labor-management committee established pursuant to the federal Labor Management Cooperation Act of 1978 (Section 175a of Title 29 of the United States Code) shall be marked or obliterated only to prevent disclosure of an individual's name and social security number. Notwithstanding any other provision of law, agencies that are included in the Joint Enforcement Strike Force on the Underground Economy established pursuant to Section 329 of the Unemployment Insurance Code and other law enforcement agencies investigating violations of law shall, upon request, be provided non-redacted copies of certified payroll records.
- 13.8.1.1.5 The Contractor shall inform the District of the location of all payroll records, including the street address, city and county, and shall, within five working days, provide a notice of a change of location and address.
- 13.8.1.1.6 The Contractor or Subcontractor(s) shall have 10 calendar days in which to comply subsequent to receipt of a written notice requesting payroll records. In the event that the Contractor or Subcontractor(s) fails to comply within the 10-day period, the Contractor or Subcontractor(s) shall, as a penalty to the District, forfeit One Hundred Dollars (\$100.00) for each calendar day, or portion thereof, for each worker, until strict compliance is effectuated. Upon the request of the Division of Apprenticeship Standards or the Division of Labor Standards Enforcement, these penalties shall be withheld from progress payments then due.

Responsibility for compliance with this Article shall rest upon the Contractor.

13.8.2 Withholding of Contract Payments & Penalties

The District may withhold or delay contract payments to the Contractor and/or any Subcontractor if:

- a. The required prevailing rate of per diem wages determined by the Director of the Department of Industrial Relations is not paid to all workers employed on the Project; or
- 13.8.2.1.1 The Contractor or Subcontractor(s) fail to submit all required certified payroll records with each application for payment, but not less than once per month; or
- 13.8.2.1.2 The Contractor or Subcontractor(s) submit incomplete or inadequate payroll records; or

GENERAL CONDITIONS

- 13.8.2.1.3 The Contractor or Subcontractor(s) fail to comply with the Labor Code requirements concerning apprentices; or
- 13.8.2.1.4 The Contractor or Subcontractor(s) fail to comply with any applicable state laws governing workers on public works projects.

13.9 APPRENTICES

13.9.1 Apprentice Wages and Definitions

All apprentices employed by the Contractor to perform services under the Contract shall be paid the standard wage paid to apprentices under the regulations of the craft or trade for which he or she is employed, and as determined by the Director of the Department of Industrial Relations, and shall be employed only at the craft or trade to which he or she is registered. Only apprentices, as defined in §3077 of the Labor Code, who are in training under apprenticeship standards that have been approved by the Chief of the Division of Apprenticeship Standards and who are parties to written apprenticeship agreements under Chapter 4 (commencing with §3070) of Division 3, are eligible to be employed under this Contract. The employment and training of each apprentice shall be in accordance with the apprenticeship standards and apprentice agreements under which he or she is training, or in accordance with the rules and regulations of the California Apprenticeship Council.

13.9.2 Employment of Apprentices

Contractor agrees to comply with the requirements of Labor Code §1777.5. The Contractor awarded the Project, or any Subcontractor under him or her, when performing any of the Work under the Contract or subcontract, employs workers in any apprenticeable craft or trade, the Contractor and Subcontractor shall employ apprentices in the ratio set forth in Labor Code §1777.5. The Contractor or any Subcontractor must apply to any apprenticeship program in the craft or trade that can provide apprentices to the Project site for a certificate approving the contractor or subcontractor under the apprenticeship standards for the employment and training of apprentices in the area or industry affected. However, the decision of the apprenticeship program to approve or deny a certificate shall be subject to review by the Administrator of Apprenticeship. The apprenticeship program or programs, upon approving the Contractor or Subcontractor, shall arrange for the dispatch of apprentices to the Contractor or Subcontractor upon the Contractor's or Subcontractor's request. "Apprenticeable craft or trade" as used in this Article means a craft or trade determined as an apprenticeable occupation in accordance with the rules and regulations prescribed by the California Apprenticeship Council. The ratio of work performed by apprentices to journeyman employed in a particular craft or trade on the Project shall be in accordance with Labor Code §1777.5.

13.9.3 Submission of Contract Information

Prior to commencing Work on the Project, the Contractor and Subcontractors shall submit contract award information to the applicable apprenticeship program(s) that can supply apprentices to the Project and make the request for the dispatch of apprentices in accordance with the Labor Code. The information submitted shall include an estimate of journeyman hours to be performed under the Contract, the number of apprentices proposed to be employed, and the approximate dates the apprentices would be employed. A copy of this information shall also be submitted to the District if requested. Within 60 days after concluding Work on the Project, the Contractor and Subcontractors shall submit to the District, if requested, and to the apprenticeship program a verified statement of the journeyman and apprentice hours performed on the Project.

GENERAL CONDITIONS

13.9.4 Apprentice Fund

The Contractor or any Subcontractor under him or her, who, in performing any of the Work under the Contract, employs journeymen or apprentices in any apprenticeable craft or trade shall contribute to the California Apprenticeship Council the same amount that the Director determines is the prevailing amount of apprenticeship training contributions in the area of the Project. The Contractor and Subcontractors may take as a credit for payments to the California Apprenticeship Council any amounts paid by the Contractor or Subcontractor to an approved apprenticeship program that can supply apprentices to the Project. The Contractor and Subcontractors may add the amount of the contributions in computing his or her bid for the Contract.

13.9.5 Prime Contractor Compliance

The responsibility of compliance with Article 13 and §1777.5 of the Labor Code for all apprenticeable occupations is with the Prime Contractor. Any Contractor or Subcontractor that knowingly violates the provisions of this Article or Labor Code §1777.5 shall be subject to the penalties set forth in Labor Code §1777.7.

13.10 ASSIGNMENT OF ANTITRUST CLAIMS

13.10.1 Application

Pursuant to Government Code § 4551, in entering into a public works contract or a subcontract to supply goods, services, or materials pursuant to a public works contract, the Contractor or Subcontractor offers and agrees to assign to the District all rights, title, and interest in and to all causes of action it may have under Section 4 of the Clayton Act, (15 U.S.C. § 15) or under the Cartwright Act (Chapter 2 [commencing with § 16700] of Part 2 of Division 7 of the Business and Professions Code), arising from the purchase of goods, services, or materials pursuant to the public works contract or the subcontract. This assignment shall be made and become effective at the time the awarding body tenders Retention Payment to the Contractor, without further acknowledgment by the parties. If the District receives, either through judgment or settlement, a monetary recovery for a cause of action assigned under Chapter 11 (commencing with § 4550) of Division 5 of Title 1 of the Government Code, the assignor shall be entitled to receive reimbursement for actual legal costs incurred and may, upon demand, recover from the District any portion of the recovery, including treble damages, attributable to overcharges that were paid by the assignor but were not paid by the District as part of the bid price, less the expenses incurred in obtaining that portion of the recovery.

13.10.2 Assignment of Claim

Upon demand in writing by the assignor, the District shall, within one (1) year from such demand, reassign the cause of action assigned pursuant to this Article if the assignor has been or may have been injured by the violation of law for which the cause of action arose and the District has not been injured thereby or the District declines to file a court action for the cause of action.

13.11 STATE AND DISTRICT CONDUCTED AUDITS

Pursuant to and in accordance with the provisions of Government Code § 10532, or any amendments thereto, all books, records, and files of the District, the Contractor, or any Subcontractor connected with the performance of this Contract involving the expenditure of state funds in excess of Ten Thousand Dollars (\$10,000.00), including, but not limited to, the administration thereof, shall be subject to

GENERAL CONDITIONS

the examination and audit of the Office of the Auditor General of the State of California for a period of five (5) years after Retention Payment is made or a Notice of Completion is Recorded, whichever occurs first. Contractor shall preserve and cause to be preserved such books, records, hard drives, electronic media, and files for the audit period.

Pursuant to the remedies under Public Contract Code section 9201 and Government Code section 930.2, Contractor, through execution of this Agreement, also agrees the District shall have the right to review and audit, upon reasonable notice, the books and records of the Contractor concerning any monies associated with the Project. The purpose of this "Audit" is to quickly and efficiently resolve Disputes based on the actual costs incurred and to reduce the uncertainty in resolving Disputes with limited information. The District shall perform any audits at its own cost and any such audit shall be performed by an independent auditor, having no direct or indirect relationship with the functions or activities being audited or with the business conducted by the Contractor or District. In the event the independent auditor determines that Change Orders, response to Request for Proposals, Claims, Appeal of Claims, or other requests for payment are in error, or have any other concerns or questions, the Auditor shall report the results of the Audit findings to the District and provide a copy to the Contractor after giving the District Board the opportunity for at least 10 days review. If the Contractor disputes the findings of the independent auditor, such dispute shall be handled in the manner set forth under Article 4.6.2 entitled Disputes.

If Contractor having agreed to the terms of this Contract fails to produce books or records requested by Auditor, such failure to produce books or records that were required to be preserved for audit, it shall be presumed that the information contained in the withheld books or records were unfavorable to the Contractor and the Auditor shall note this refusal in the results of the Audit findings for further evaluation by the District and the District's Board. The refusal to release records that are concerning monies associated with the Project may be used as a grounds to debar the Contractor under Article 15 for failure to preserve records under Article 13.11 and the failure to produce required audit records may also be used as a grounds for a negative finding against the Contractor depending on the significance of the records that are withheld by Contractor. Failure to produce job cost data tied to job cost categories and budgets shall be presumed an intentional failure to produce key audit records. Similarly, failure to produce Daily Reports (prepared at or near the time of the Work actually took place (See Article ARTICLE 1) shall be presumed an intentional failure to produce key audited records.

If Contractor is seeking costs for inefficiency, home office overhead, or unanticipated increased costs due to delays or acceleration, Contractor shall also produce copies of the original bid tabulation utilized in submitting Contractor's bid for the Project. This document shall be considered confidential and shall not be subject to disclosure through a Public Records Act and shall not be distributed to anyone other than the District and the District's counsel. This bid tabulation shall only be used in litigation, arbitration, evaluation of Claims or Disputes, Audit, and trial. If the records for the bid tabulation are kept on a computer, the Contractor shall also produce all metadata (in native format) that accompanies the bid tabulation for inspection to prove the authenticity of the underlying bid tabulation. Failure to produce the bid tabulation for review of inefficiency, home office overhead, or unanticipated increased costs due to delays or accelerations shall be considered material evidence that the bid tabulation was not favorable to the Contractor. This evidence shall be entered as a jury instruction for trial that the bid tabulation was not produced and the bid tabulation information was unfavorable to the Contractor. The evidence may also be used in debarment proceedings, and noted as an exception to an Audit findings.

Upon notification of Contractor concerning the results of the audit and a reasonable time has passed for Contractor to respond to the Audit findings and if either there is no Dispute of the Audit findings under Article 4.6 or if the result after utilizing the Disputes Clause confirms the Audit findings,

GENERAL CONDITIONS

the District may seek reimbursement for overstated Claims, Change Orders, or Appeal of Claims and may also undertake debarment proceedings under Article 15 of these General Conditions.

13.12 STORM WATER POLLUTION PREVENTION

13.12.1 Application

This Section addresses the preparation, implementation and monitoring of a Storm Water Pollution Prevention Plan (SWPPP) for the purpose of preventing the discharge of pollutants from the construction site. This includes the elimination of pollution discharges such as improper dumping, spills or leakage from storage tanks or transfer areas. The District will not issue a Notice to Proceed until Contractor has prepared by a qualified individual and obtained approval of the Permit Registration Documents ("PRDs") that include a Notice of Intent, Construction Risk Calculation, Site Map, SWPPP, Annual Fee and any additional required documents from all applicable Local Governing Agencies including the Regional Water Quality Control Board. The Contractor shall also secure a certification that the Project has met all of the conditions of the General Construction Activity Storm Water Permit (GCASP) and comply with all applicable local, state and federal regulations governing storm water pollution prevention.

13.12.2 References and Materials

- California Stormwater Quality Association New Development and Redevelopment Best Management Practice Handbook
- 2009 California Stormwater Quality Association Construction BMP Handbook .
- State Water Resources Control Board (2009). Order 2009-0009-DWQ, NPDES General Permit No. CAS000002: Waste Discharge Requirements for Discharges of Storm Water Runoff Associated with Construction and Land Disturbing Activities. Available on-line at:
- http://www.waterboards.ca.gov/water_issues/programs/stormwater/construction.shtml.- Use materials of a class, grade and type needed to meet the performance described in the BMP Handbook.

13.12.3 Preparation and Approval

The Contractor shall prepare by a qualified individual the PRDs that include a Notice of Intent, Construction Risk Calculation, Site Map, SWPPP, Annual Fee and any additional required documents. The Contractor's Qualified SWPPP Developer ("QSD") shall prepare the Storm Water Pollution Prevention Plan (SWPPP) as required to comply with storm water pollution regulations for project sites with storm water discharges associated with construction activity such as clearing or demolition, grading, excavation and other land disturbances. The SWPPP shall apply to all areas that are directly related to construction activity, including but not limited to staging areas, storage yards, material borrow areas, and access roads.

13.12.3.1 The Contractor shall prepare and submit to the Local Governing Agencies and the District the SWPPP for review and approval if the project sites, new or existing, with land disturbance of 1 or more acres (or less than 1 acres if part of a common plan of development); the construction activity that results in land surface disturbances of less than one acre is part of a larger common plan of development or sale of one or more acres of disturbed land surface; or the construction activity associated with Linear Underground/Overhead Projects ("LUPs") including, but not limited

GENERAL CONDITIONS

to, those activities necessary for the installation of underground and overhead linear facilities (e.g., conduits, substructures, pipelines, towers, poles, cables, wires, connectors, switching, regulating and transforming equipment and associated ancillary facilities) and include, but are not limited to, underground utility mark-out, potholing, concrete and asphalt cutting and removal, trenching, excavation, boring and drilling, access road and pole/tower pad and cable/wire pull station, substation construction, substructure installation, construction of tower footings and/or foundations, pole and tower installations, pipeline installations, welding, concrete and/or pavement repair or replacement, and stockpile/borrow locations.

13.12.3.2 The Contractor shall also pay annual renewal fee(s) until the contract is completed and make all such checks payable to the State Water Resources Control Board. The Notice of Intent must be submitted at least two weeks prior to the commencement of construction activities.

13.12.3.3 The Contractor shall prepare the SWPPP by following the format in Sections 2, 3, 4 and Appendices A through F of the California Stormwater BMP Handbook - Construction, January 2009 edition, published by the California Stormwater Quality Association. The publication is available from:

California Stormwater
Quality Association
P.O. Box 2105
Menlo Park, CA 94026-2105
Phone: (650) 366-1042
E-mail: info@casqa.org

or

<https://www.casqa.org/store/products/tabid/154/p-167-construction-handbookportal-initial-subscription.aspx>

13.12.3.4 Where land disturbance is less than 1 acre, any BMPs indicated in the BMP Handbook needed to prevent or minimize storm water pollution shall be implemented at no extra cost to the District.

13.12.3.5 Within two weeks after Award of Contract by the District, the Contractor shall submit to the District's Civil Engineer one copy of the PRDs including the SWPPP for review. After the District's approval, the Contractor shall provide approved copies of the SWPPP as follows: one copy each to the Project Inspector, Construction Manager, Architect, Commissioned Architect and District's Civil Engineer.

13.12.4 Implementation

The Contractor shall implement the Storm Water Pollution Prevention Plan by doing the following:

- a. Obtain a Waste Discharger Identification (WDID) number from the SWRCB before beginning construction. This number will be issued once your PRDs are administratively accepted and fee is received.

13.12.4.1.1 Keep the SWPPP, REAPs, monitoring data on the construction site.

GENERAL CONDITIONS

- 13.12.4.1.2 Employ a Qualified SWPPP Practitioner (QSP) to implement the SWPPP during construction and develop Rain Event Action Plans ("REAPs").
- 13.12.4.1.3 Install, inspect, maintain and monitor BMPs required by the General Permit.
- 13.12.4.1.4 Install perimeter controls prior to starting other construction work at the site.
- 13.12.4.1.5 Contain on-site storm water at the jobsite. Do not drain on-site water directly into the storm drain.
- 13.12.4.1.6 Implement the SWPPP.
- 13.12.4.1.7 Provide SWPPP and BMP implementation training for those responsible for implementing the SWPPP.
- 13.12.4.1.8 Designate trained personnel for the proper implementation of the SWPPP.
- 13.12.4.1.9 Conduct monitoring, as required, and assess compliance with the Numeric Action Levels (NALs) or Numeric Effluent Limitations (NELs) appropriate to your project.
- 13.12.4.1.10 Report monitoring data:
 - 13.12.4.1.10.1 Maintain a paper or electronic copy of all required records for three years from the date generated or date submitted, whichever is last. These records must be available at the construction site until construction is completed.
 - 13.12.4.1.10.2 Have a QSD revise the SWPPP as needed to reflect the phases of construction and to suit changing site conditions and instances when properly installed systems are ineffective.
 - 13.12.4.1.10.3 Assist the District with entering any necessary data or information into the Stormwater Multi-Application and Reporting System ("SMARTS") system.
- 13.12.4.1.11 At the end of Construction Contract:
 - 13.12.4.1.11.1 Submit Notice of Termination (NOT) into the SMARTS when construction is complete and conditions of termination listed in the NOT have been satisfied. A copy of the NOT can be found at:
http://www.waterboards.ca.gov/water_issues/programs/stormwater/construction.shtml.
 - 13.12.4.1.11.2 Leave in place storm water pollution prevention controls needed for post-construction storm water management and remove those that are not needed as determined by the District. Thereafter, left-in-place controls will be maintained by the District.
 - 13.12.4.1.11.3 Provide Site Monitoring Reports, SWPPP revisions, Compliance Certifications and related documents to the District. Post-construction storm water operation and management plan as mentioned in the compliance certifications are considered to be in place at the end of the Construction Contract.
- 13.12.5 Monitoring

GENERAL CONDITIONS

The Contractor shall conduct examination of storm water pollution prevention controls as required by the State Water Resources Control Board (2009). Order 2009-0009-DWQ, NPDES General Permit No. CAS000002: Waste Discharge Requirements for Discharges of Storm Water Runoff Associated with Construction and Land Disturbing Activities. This includes properly qualified personnel performing all required monitoring, testing, inspections and monitoring. The Contractor shall also conduct examination of storm water pollution prevention controls, as well as before and after each storm event in compliance with the State Water Resources Control Board Order No. 2009-0009-DWQ, National Pollutant Discharge Elimination System General Permit No. CAS000002, Waste Discharge Requirements for Discharges of Storm Water Runoff Associated with Construction and Land Disturbance Activities (General Permit) (SWRCB, 2009).and at least once each 24-hour period during extended storm events to identify BMP effectiveness and implement repairs or BMP changes as soon as feasible. All maintenance related to a storm event should be completed within 48 hours of the storm event. The Contactor shall also prepare and maintain, at the jobsite, a log of each inspection using Site Monitoring Report forms.

13.12.6 Liabilities and Penalties

- 13.12.6.1.1 Review of the SWPPP and inspection logs by the District shall not relieve the Contractor from liabilities arising from non-compliance with storm water pollution regulations.
- 13.12.6.1.2 Payment of penalties for non-compliance by the Contractor shall be the sole responsibility of the Contractor and will not be reimbursed by the District.
- 13.12.6.1.3 Compliance with the Clean Water Act pertaining to construction activity is the sole responsibility of the Contractor. For any fine(s) levied against the District due to non-compliance by the Contractor, the District will deduct from the final payment due the Contractor the total amount of the fine(s) levied on the District, plus legal and associated costs.
- 13.12.6.1.4 The Contractor shall submit to the District a completed NOI for change of information (Construction Site Information and Material Handling/Management Practices).

GENERAL CONDITIONS

14

TERMINATION OR SUSPENSION OF THE CONTRACT

14.1 TERMINATION BY THE CONTRACTOR FOR CAUSE

14.1.1 Grounds for Termination

The Contractor may terminate the Contract if the Work is stopped for a period of thirty (30) consecutive days through no act or fault of the Contractor, a Subcontractor, a Sub-subcontractor, their agents or employees, or any other persons performing portions of the Work for whom the Contractor is contractually responsible, for only the following reasons:

- a. Issuance of an order of a court or other public authority having jurisdiction; or

- 14.1.1.1.1 An act of the United State or California government, such as a declaration of national emergency.

14.1.2 Notice of Termination

If one of the above reasons exists, the Contractor may, upon written notice of seven (7) additional days to the District, terminate the Contract and recover from the District payment for Work executed and for reasonable costs verified by the Architect with respect to materials, equipment, tools, construction equipment, and machinery, including reasonable overhead, profit, and damages.

14.2 TERMINATION BY THE DISTRICT FOR CAUSE

14.2.1 Grounds for Termination

14.2.2 The District may Z the Contractor and/or this Contract for the following reasons:

- a. Persistently or repeatedly refuses or fails to supply enough properly skilled workers or proper materials;

- 14.2.2.1.1 Persistently or repeatedly is absent, without excuse, from the job site;

- 14.2.2.1.2 Fails to make payment to Subcontractors, suppliers, materialmen, etc.;

- 14.2.2.1.3 Persistently disregards laws, ordinances, rules, regulations, or orders of a public authority having jurisdiction;

- 14.2.2.1.4 Fails to provide a schedule or fails or refuses to update schedules required under the Contract;

- 14.2.2.1.5 Falls behind on the Project and refuses or fails to undertake a Recovery Schedule;

- 14.2.2.1.6 If the Contractor has been debarred from performing Work

- 14.2.2.1.7 Becomes bankrupt or insolvent, including the filing of a general assignment for the benefit of creditors; or

GENERAL CONDITIONS

14.2.2.1.8 Otherwise is in substantial breach of a provision of the Contract Documents.

14.2.3 Notification of Termination

When any of the above reasons exist, the District may, without prejudice to any other rights or remedies of the District and after giving the Contractor and the Contractor's Surety written notice of seven (7) days, terminate the Contractor and/or this Contract and may, subject to any prior rights of the Surety:

- a. Take possession of the Project and of all material, equipment, tools, and construction equipment and machinery thereon owned by the Contractor;

14.2.3.1.1 Accept assignment of Subcontracts. Contractor acknowledges and agrees that if the District (in its sole and absolute discretion) decides to takeover completion of the Project, the Contractor agrees to immediately assign all subcontracts to the District which the District has chosen to accept;

14.2.3.1.2 Complete the Work by any reasonable method the District may deem expedient, including contracting with a replacement contractor or contractors; and,

14.2.3.1.3 Agree to accept a takeover and completion arrangement with Surety that is acceptable to the District Board.

14.2.4 Takeover and Completion of Work after Termination for Cause

A Termination for Cause is an urgent matter which requires immediate radiation since Project Work is open and incomplete, the site is subject to vandalism and theft, the Project site is considered a public nuisance, and there is a possibility of injury and deterioration of the Project Work and materials. Thus, the District shall be entitled to enter a takeover contract to either remediate the unfinished condition or complete the Work for this Project.

14.2.5 Payments Withheld

If the District terminates the Contract for one of the reasons stated in Article 14.2.1, the Contractor shall not be entitled to receive further payment until the Work is complete. All costs associated with the termination and completion of the Project shall be the responsibility of the Contractor and/or its Surety.

14.2.6 Payments upon Completion

If the unpaid balance of the Contract Sum exceeds costs of completing the Work, including compensation for professional services and expenses made necessary thereby, such excess shall be paid to the Contractor. If such costs exceed the unpaid balance, the Contractor and its Surety shall pay the difference to the District. The amount to be paid to the Contractor, or District, as the case may be, shall be certified by the Architect upon application. This payment obligation shall survive completion of the Contract.

14.3 TERMINATION OF CONTRACT BY DISTRICT (CONTRACTOR NOT AT FAULT)

14.3.1 Termination for Convenience

GENERAL CONDITIONS

District may terminate the Contract upon fifteen (15) calendar days of written notice to the Contractor and use any reasonable method the District deems expedient to complete the Project, including contracting with replacement contractor or contractors, if it is found that reasons beyond the control of either the District or Contractor make it impossible or against the District's interest to complete the Project. In such a case, the Contractor shall have no Claims against the District except for: (1) the actual cost for approved labor, materials, and services performed in accordance with the Contract Documents which have not otherwise been previously paid for and which are supported and documented through timesheets, invoices, receipts, or otherwise; and (2) profit and overhead of ten percent (10%) of the approved costs in item (1); and (3) termination cost of five percent (5%) of the approved costs in item (1). Contractor acknowledges and agrees that if the District (in its sole and absolute discretion) decides to takeover completion of the Project, the Contractor agrees to immediately assign all subcontracts to the District which the District has chosen to accept.

14.3.2 Non-Appropriation of Funds/ Insufficient Funds

In the event that sufficient funds are not appropriated to complete the Project or the District determines that sufficient funds are not available to complete the Project, District may terminate or suspend the completion of the Project at any time by giving written notice to the Contractor. In the event that the District exercises this option, the District shall pay for any and all work and materials completed or delivered onto the site for which value is received, and the value of any and all work then in progress and orders actually placed which cannot be canceled up to the date of notice of termination. The value of work and materials not otherwise already paid for by the District up to the time of termination under this Paragraph shall include a factor of fifteen percent (15%) for the Contractor's overhead and profit and there shall be no other costs or expenses paid to Contractor. All work, materials and orders paid for pursuant to this provision shall become the property of the District. District may, without cause, order Contractor in writing to suspend, delay or interrupt the Project in whole or in part for such period of time as District may determine. Adjustment shall be made for increases in the cost of performance of the Agreement caused by suspense, delay or interruption.

14.4 REMEDIES OTHER THAN TERMINATION

If a default occurs, the District may, without prejudice to any other right or remedy, including, without limitation, its right to terminate the Contract pursuant to Article 14.2, do any of the following:

- a. Permit the Contractor to continue under this Contract, but make good such deficiencies or complete the Contract by whatever method the District may deem expedient, and the cost and expense thereof shall be deducted from the Contract Price or paid by the Contractor to the District on demand;

14.4.1.1.1 If the workmanship performed by the Contractor is faulty or defective materials are provided, erected or installed, then the District may order the Contractor to remove the faulty workmanship or defective materials and to replace the same with work or materials that conform to the Contract Documents, in which event the Contractor, at its sole costs and expense, shall proceed in accordance with the District's order and complete the same within the time period given by the District in its notice to the Contractor; or

14.4.1.1.2 Initiate procedures to declare the Contractor a non-responsible bidder for a period of two (2) to five (5) years thereafter.

GENERAL CONDITIONS

All amounts expended by the District in connection with the exercise of its rights hereunder shall accrue interest from the date expended until paid to the District at the maximum legal rate. The District may retain or withhold any such amounts from the Contract Price. If the Contractor is ordered to replace any faulty workmanship or defective materials pursuant to Paragraph (b) above, the Contractor shall replace the same with new work or materials approved by the Architect and the District, and, at its own cost, shall repair or replace, in a manner and to the extent the Architect and the District shall direct, all Work or material that is damaged, injured or destroyed by the removal of said faulty workmanship or defective material, or by the replacement of the same with acceptable work or materials. In no event shall anything in this Article be deemed to constitute a waiver by the District of any other rights or remedies that it may have at law or in equity, it being acknowledged and agreed by the Contractor that the remedies set forth in this Article are in addition to, and not in lieu of, any other rights or remedies that the District may have at law or in equity.

GENERAL CONDITIONS

15 DEBARMENT

DEBARMENT MEANS THERE HAS BEEN A FINDING THAT THE CONTRACTOR IS NOT RESPONSIBLE.

During the course of the Project, or if it is determined through Change Orders, Claims, or Audit that a Contractor is not responsible, the District may, in addition to other remedies provided in the Contract, debar the Contractor from bidding or proposing on, or being awarded, and/or performing work on District contracts for a specified period of time, which generally will not exceed five (5) years, but may exceed five (5) years or be permanent if the circumstances warrant such debarment. In addition to the debarment proceeding, a finding that a Contractor is to be debarred shall result in the termination of any or all existing Contracts the Contractor may have with the District.

15.1 BOARD FINDING

The District may debar a Contractor if the Board, or the Board's delegatee, in its discretion, finds the Contractor has done any of the following:

- 15.1.1 Intentionally or with reckless disregard, violated any term of the Contract with the District
- 15.1.2 Committed an acts or omission which reflects on the Contractor's quality, fitness or capacity to perform Work for the District;
- 15.1.3 Committed an act or offense which indicates a lack of business integrity or business honesty; or,
- 15.1.4 Made or submitted a false claim against the District or any other public entity.

15.2 HEARING AND PRESENTATION OF EVIDENCE

If there is evidence that the Contractor may be subject to debarment, the District shall notify the Contractor in writing of the evidence which is the basis for the proposed debarment and shall advise the Contractor of the scheduled date for a debarment hearing before the District Board or its delegated designee.

The District Board, or designee, shall conduct a hearing where evidence on the proposed debarment is presented. The Contractor or the Contractor's representative shall be given an opportunity to submit evidence at the hearing. The Contractor shall be provided an adequate amount of time to prepare and object to evidence presented. A tentative proposed decision shall be issued as a tentative decision and the District shall be entitled to modify, deny or adopt the proposed decision. The proposed decision shall contain a recommendation regarding whether the Contractor should be debarred, and, if so, the appropriate length of time of the debarment. The Contractor and the District shall be provided an opportunity to object to the tentative proposed decision for a period of 15 days. If additional evidence is presented, the District shall evaluate this evidence and either issue an amended ruling, issue the same ruling, or call a further hearing.

If a Contractor has been debarred for a period of longer than five (5) years, that Contractor may after the debarment has been in effect for at least five (5) years, submit a written request for review of the debarment determination to reduce the period of debarment or terminate the debarment. The District may,

GENERAL CONDITIONS

in its discretion, reduce the period of debarment or terminate the debarment if it finds that the Contractor has adequately demonstrated one or more of the following: (1) elimination of the grounds for which the debarment was imposed; (2) a bona fide change in ownership or management; (3) material evidence discovered after debarment was imposed; or (4) any other reason that is in the best interests of the District.

The District will consider a request for review of a debarment determination only where: (1) the Contractor has been debarred for a period longer than five (5) years; (2) the debarment has been in effect for at least five (5) years; and (3) the request is in writing, states one or more of the grounds for reduction of the debarment period or termination of the debarment and includes supporting documentation. Upon receiving an appropriate request, the District will provide notice of the hearing on the request. At the hearing, the District shall review evidence on the proposed reduction of debarment period. This hearing shall be conducted and the request for review decided by the District pursuant to the same procedures as for a debarment hearing.

The District's proposed decision shall contain a recommendation on the request to reduce the period of debarment or terminate the debarment.

The terms shall also apply to Subcontractors of Contractor.

SUPPLEMENTARY GENERAL CONDITIONS

CERTIFICATE OF SUBSTANTIAL COMPLETION

PROJECT: _____

TO: _____

As the Architect for the Project described above, the Project has reached Substantial Completion. Substantial Completion is not reached unless and until each of the following three (3) conditions have been met: (1) all contractually required items have been installed with the exception of only minor and Incomplete Punch Items (See Article 9.9 of the General Conditions); (2) All Fire/Life Safety Systems have been installed, and are working and signed off on the DSA Form 152 Inspection Card, all building systems including mechanical, electrical and plumbing are all functioning; and (3) the Project is fit for occupancy and its intended use

I certify that the Project has reached Substantial Completion as defined above on the following date:
_____.

Architect

SUPPLEMENTARY GENERAL CONDITIONS

DOCUMENT 00 7300
SUPPLEMENTAL GENERAL CONDITIONS

1.01 GENERAL

A. The conditions hereinafter specified shall apply to the performance of the Work of this project, the Contractor awarded the Work of the Project and all Subcontractors and Suppliers contracted or hired for the work of this Project and any other contractors the District may choose to hire for this Project.

B. All conditions set forth in Bidding Documents, or any other portion of the Contract Documents, shall apply to the fullest extent except where they are in conflict with these Supplemental Conditions. In the event of such conflict, these Supplemental Conditions shall take precedence.

C. Governing Codes: Title 24, C.C.R.: A copy of Part I through Part V of California Title 24 shall be kept on the jobsite in the office of the Contractor's Project Superintendent.

D. All work performed under this contract shall comply in every respect to the rules and regulations of all agencies having jurisdiction for this classification of construction and design. These rules and regulations include California Code of Regulations, Title 24 and the latest edition of the National Electric Code.

E. Work shall not begin before nor more than one year after Division of State Architect (DSA) approval of plans and specifications per Title 24, Part I, Article 5, Section 4-330.

F. The School District shall have a DSA approved project inspector of record per Title 24, Part I, Article 5, Section 4-333. This inspector shall inspect every part of the work and shall make other notifications per Title 24, Part I, Section 4-342.

G. All required tests and inspections necessary to comply with statutory requirements shall be paid for by the District and reports shall be forwarded to DSA, the Architect, the Contractor and the Inspector of Record in accordance with Title 24, Part I, Section 4-335.

H. Semimonthly reports shall be submitted by the Inspector of Record to the Architect per Title 24, Part I, Section 4-337.

I. No changes or alterations of the approved plans and specifications shall be made without a DSA approved Construction Change Document in accordance with Title 24, Part I, Sections 4-343(c) and 4-336. All Addenda, change orders shall be approved by DSA per Section 4-338 (a). Any modification to DSA approved plans and specifications that affect structural safety, fire and life safety, access compliance or energy (as applicable) shall be submitted to the Division of State Architect for review and approval.

J. Supervision shall be performed by DSA in accordance with Title 24, Part I, Section 4-334.

K. Contractor(s) shall be required to submit regular and final Verified Report form DSA 6, current version. Contractor to provide copies of each submitted Verified Report to the Architect and the Division of State Architect. The duties of the Contractor under this contract shall be as enumerated in Part I, Title 24, C.C.R., Section 4-343.

L. Deferred approval items are indicated on the drawings. These items cannot be fabricated prior to DSA approval. Submission to DSA will not be permitted without prior approval of Architect. Contractor is hereby notified that it has the express responsibility for submission of shop drawings, submittals, product data and samples to DSA, as well as responsibility for obtaining DSA approval of deferred approval item.

M. Weekly job foreman / job superintendent meetings will be conducted by the Contractor to coordinate on-going construction issues. The Contractor shall require each subcontractor shall cause its designated job foreman or job superintendent to attend each coordination meeting, as scheduled by the Contractor.

N. The Contractor shall attend progress meetings as scheduled by the Architect for discussion of issues of administrative or design consideration with the District's Representative(s), the Inspector of Record and the Architect. The Contractor shall cause its project manager or project administrator to attend each progress meeting.

O. Division 1 of the Specifications further defines the intent of the General and Supplemental Conditions with respect to but not limited to: Summary of Work, Administrative Procedures, Definitions, Reference Standards, Quality Control, Temporary Facilities and Controls, Temporary Signage, Project Closeout. The requirements of Division 1 complement those of the Supplemental and General Conditions.

P. DSA is not subject to arbitration.

1.02 TESTING

A. To assist the District in the process of obtaining qualified and responsive quotations for testing and inspection services for the Project, Contractor shall submit with Contractor's baseline schedule, a schedule of required inspections and tests which includes the following information as a minimum:

- 1) Name of Special Inspection or Test;
- 2) Quantity or frequency of Special Inspections or Tests;
- 3) Projected Dates upon which Special Inspections and Tests are required.

B. The Contractor(s) shall furnish said schedule of required inspections and tests, based on the requirements of the Contract Documents, local regulatory codes and the Contractor's expertise in its field, at the same time required for submission of Contractor's Baseline Schedule in accordance with specification Section 01 3200. The District will provide all submitted schedules to the Testing Agency in accord with governing codes. The Contractor hereby acknowledges and agrees that, in the event additional testing and inspection costs are incurred due to failure of initial tests, cost for same shall be reimbursed to the Owner by the Contractor.

C. Testing will be performed by the Owner's Testing Agency in accordance with Title 24, Part I Section 4-335.

D. Special Inspection will be performed by the Owner's Testing Agency in accordance with Title 24, Part I Section 4-333 (c).

1.03 SURVEYING, LINES AND GRADES

A. Each Contractor awarded Work for this Project shall provide all necessary surveying, layout, lines and grades required for the proper location of the Work.

B. Contractor agrees to provide any and all false-work, templates, batter-boards and other such structures or devices necessary to provide for the Contractor's layout, lines and grades. Work installed in an incorrect location or elevation shall be removed and re-installed at the expense of the Contractor.

1.04 FIRE MARSHAL REQUIREMENTS

A. Contractors must provide and maintain safe access for emergency vehicle traffic in accord with local fire marshal regulations.

1.05 CONTRACT DOCUMENTS

A. No "conformed" sets of Contract Documents will be made available. The Contractor is responsible for reviewing and incorporating all addendum changes into the Contract Documents used by him for construction. All sums necessary for performance of this work shall be included in the Bid Proposal.

B. No reduced-size sets of Contract Documents will be made available.

C. Documents Valid at Full Size Only in Original Formats:

1. The Drawings, Specifications, or other documents prepared or supplied by Quattrocchi Kwok Architects for this project were prepared and intended to be prepared for viewing and use at the full original document sizes of 42 by 30 inches, 36 by 24 inches, 17 by 11 inches, and 8.5 by 11 inches, and that specifically, the line types / thicknesses, hatch patterns, textures, typeface designs, font sizes and any and all other forms of written or graphic communications and formats included therein were selected specifically by the authors of the documents to be read only at the full original document size.
2. Modifications such as enlargement, reduction, automated conversion, scanning and/or translation, or transition of information and data from the system and format used by Quattrocchi Kwok Architects to an alternate size, whether enlarged or reduced, or to another system format such as scanning to electronic format or media may result in the introduction of inexactitudes, anomalies and errors.
3. Modification of any of the Drawings, Specifications, or other documents or data prepared or supplied by Quattrocchi Kwok Architects, denotes assumption of all responsibility and risk for such errors and for the proper use of the modified document(s) by the modifying party.

4. Originals of all Drawings, Specifications or other documents and data prepared for this Project are originals retained by Quattrocchi Kwok Architects, and in whatever medium, shall be referred to and shall govern in the event of any inconsistency between them and any Drawings, Specifications, or other documents and data modified by any party.

D. Electronic Files shall be made available to the Contractor only following receipt of the attached QKA provided Electronic File Release Form signed by authorized representative of the Contractor attesting to agreement with terms of the release form. As stated in by the Electronic Release Form and represent above the files provided are a working product, may not fully conform to the Contract Documents and are utilized by the Contractor at Contractor's sole risk.

E. Contractor shall utilize web-resident data base administered through the Architect for construction clarifications, modifications and submittal review. Architect will provide required program training and access to Project data base. Further directions in regard to establishment and use of data base is found in corresponding Division 01 General Requirements.

1.06 SUBSTITUTIONS

A. The materials, products, and equipment described in the Contract Documents establish a standard of required function, dimension, appearance, and quality. Architect may consider requests for substitutions of specified equipment, materials, or products and then only when requests are submitted in accordance with the provisions of the Contract Documents governing substitutions, and are received by Architect within the time period therein established. No substitutions will be considered after the date or receipt of the bid or contract award unless there is cause for a substitution which complies in every respect to the provisions of the Contract Documents governing substitutions. Refer to Division 01 Section specifying Product Requirements, for detailed instructions regarding substitution limitations and procedures.

1.08 FORCE ACCOUNT PROCEDURES

A. In the event the Contractor is required or authorized to perform work on a force account basis, in accord with the GENERAL CONDITIONS Article titled "Modifications of Contract", the Contractor shall comply with the following reporting requirements:

B. Contractor shall, at the end of each day during which Force Account work is performed, submit a detailed and complete time sheet or time card indicating total labor hours spent and classification, total equipment hours spent and classification, total materials and sales tax, and any other measurable costs associated with the performance of the work. The Contractor shall submit said time sheet to the Owner's Inspector and both parties shall sign the time sheet as evidence that both parties acknowledge and agree to the extent of the work performed. Failure on the part of the Contractor to comply with the foregoing procedures will be cause for the Contractor to forfeit any payment or claim for said Force Account work not signed for. The District and Contractor may, based upon mutual agreement, proceed with Force Account work on a Time and Materials basis, with total cost "not-to-exceed" any quotation tendered for said Force Account item(s).

1.9 DISPUTED WORK PROCEDURES

A. The District may, in case of a disputed work item, direct the Contractor to perform the disputed work at no additional cost to the District, stating its belief that the work is clearly or adequately indicated in the Contract Documents, and therefore may be properly classified as an item for which prices are established in the Contract. In the event the Contractor maintains that the disputed work represents a modification to the Contract, Contractor may pursue reimbursement in accordance with Article titled RESOLUTION OF CONSTRUCTION CLAIMS of the General Conditions.

1.10 THIRD PARTY UTILITIES

A. Should the Contractor encounter a third party owned utility not shown or noted on the drawings, the Contract adjustment allowed the Contractor shall only be for the direct costs of removing, altering or relocating the utility, as needed, and an excusable, non-compensable time extension for the amount of time that such extra work affects the end date of the work. The Contractor shall not be entitled to damages or additional payment for delays attributable to such additional work as is required for removing, relocating, or altering utilities not shown or noted on the drawings. The Owner will not be entitled to assess liquidated damages for this amount of time.

1.12 ACCESS TO THE SITE

A. Contractor is notified that the Site is congested, with limited access. It shall be the Contractor's responsibility to coordinate Contractor's Work with the Work of other Prime Contractors performing work on the site. Areas designated by the Owner shall remain off-limits to construction personnel and equipment during construction.

END OF DOCUMENT

ELECTRONIC FILE RELEASE FORM FOLLOWS

0000.00-O-1.1



QUATTROCCHI KWOK
ARCHITECTS

Electronic Release Form

Contractor Contact
Contractor
Address
Address

Project Name
Project Number:
DSA Application:
DSA File:

Electronic files listed below will be sent to you, as allowed, upon receipt of a signed copy of this disclaimer.

The following applies to all information whatsoever, whether or not specifically identified below, which is being provided electronically.

Recipient understands and agrees that the information contained within these files is the internal working information of Quattrocchi Kwok Architects. Such internal working information is not intended as a finished product and may contain erroneous, extraneous, or incomplete information. All information contained on therein is preliminary and subject to change or correction without notice. Said information is furnished at the request of Recipient, for his sole convenience, and Recipient agrees to assume all responsibilities and risks of its use.

The Drawings, Specifications, or other documents prepared or supplied by Quattrocchi Kwok Architects for this project, whether in hard copy or machine readable form, are instruments of Quattrocchi Kwok Architects' service for one-time use solely with respect to this project. As such, they shall be deemed the property of Quattrocchi Kwok Architects who shall retain all common law, statutory and other reserved rights, including copyright. No Drawings, Specifications or other documents and data prepared or supplied by Quattrocchi Kwok Architects may be used on this project after Quattrocchi Kwok Architects' involvement is completed or on any other Project without Quattrocchi Kwok Architects' prior written consent.

Quattrocchi Kwok Architects reserves the right to retain originals of all Drawings, Specifications or other documents and data prepared under this agreement in whatever medium Quattrocchi Kwok Architects deems appropriate. Said originals retained by Quattrocchi Kwok Architects and in whatever medium, shall be referred to and shall govern in the event any inconsistency between them and any Drawings, Specifications, or other documents and data prepared or supplied to the Undersigned by Quattrocchi Kwok Architects. If the undersigned uses any of the Drawings, Specifications, or other documents or data prepared or supplied by Quattrocchi Kwok Architects, the undersigned assumes all responsibility and risk for the proper use thereof. For example, the Undersigned acknowledges that the automated conversion and/or transition of information and data from the system and format used by Quattrocchi Kwok Architects to an alternate system format may result in the introduction of inexactitudes, anomalies and errors.

The undersigned further understands that changes or modifications to the Drawings, Specifications, other documents or data prepared or supplied by Quattrocchi Kwok Architects made by anyone other than Quattrocchi Kwok Architects, including any such automated conversion and/or translation as described above, may result in adverse consequences which Quattrocchi Kwok Architects can neither predict nor control. Therefore, and in exchange for the Undersigned obtaining copies of the Drawings, Specifications, other documents or data prepared or supplied by Quattrocchi Kwok Architects, the Undersigned agrees that should the Undersigned, or any of its agents, modify or convert any of the Drawings, Specifications other documents or data prepared or supplied by Quattrocchi Kwok Architects, the Undersigned agrees to indemnify, defend, protect and hold Quattrocchi Kwok Architects harmless from and against any and all claims, liabilities, suits, demands, losses, costs and expenses, including reasonable attorney's fees, accruing or resulting to any and all persons, firms or any other legal entity, on account of any damage or loss to property or persons, including death, arising out of or in any way connected with, the modification or conversion of the Drawings, Specifications, other documents or data prepared or supplied by Quattrocchi Kwok Architects, whether in hard copy or machine readable form, except where Quattrocchi Kwok Architects is found to be solely liable for such damages or losses by a court or forum of competent jurisdiction. The foregoing indemnification applies, without limitation, to any modification or conversion of the Drawings, Specifications, other documents or data prepared or supplied by Quattrocchi Kwok Architects on other projects and for completion of, remodel of, or additions to this project.

List of requested documents and/or data:

Agreed to by CONTRACTOR:
Contractor Name

By: _____

Date: _____

SECTION 01 2600
MODIFICATION PROCEDURES

PART 1 GENERAL

1.01 SECTION INCLUDES

- A. Submittals.
- B. Documentation of change in Contract Sum and Contract Time.
- C. Change procedures.
- D. Execution of change orders.
- E. Correlation of Contractor submittals.

1.02 RELATED SECTIONS

- A. Document - Agreement: Monetary values of established Unit Prices.
- B. Document - General Conditions and Supplementary General Conditions: Governing requirements for changes in the Work, in Contract Sum and Contract Time and percentage allowances for Contractor's overhead and profit.
- C. Section 01 6000 - Material and Equipment: Product options and substitutions.

1.03 SUBMITTALS

- A. Submit name of the individual in Contractor's firm authorized to receive change documents, and be responsible for informing others in Contractor's employ or Subcontractors of changes to the Work.
- B. The following submittals shall be made on forms prepared by the Architect:
 - 1. Request For Information Forms.
 - 2. Architect's Supplemental Instructions Forms.
 - 3. Request For Proposal Forms.
 - 4. Change Order Forms.

1.04 DOCUMENTATION OF CHANGE IN CONTRACT SUM AND CONTRACT TIME

- A. Maintain detailed records of work done. Provide full information required for evaluation of proposed changes, and to substantiate costs of changes in the Work.
- B. Document each quotation for a change in cost or time with sufficient data to allow evaluation of the quotation.

- C. Provide additional data to support computations:
 - 1. Quantities of products, labor, and equipment.
 - 2. Taxes, insurance, and bonds.
 - 3. Overhead and profit.
 - 4. Justification for any change in Contract Time.
 - 5. Credit for deletions from Contract, similarly documented.

1.05 REQUEST FOR INFORMATION ("RFI")

- A. An RFI is a written request prepared by the Contractor asking the Architect to provide additional information necessary to clarify an item which the Contractor feels is not clearly shown or called for in the drawings or specifications, or to address questions which have arisen under field conditions.
 - 1. RFI's shall be submitted by the Contractor to the Architect on the form which is included in the project. Submittals not conforming to this requirement will be returned.
- B. The RFI shall reference all the applicable Contract Documents including specification section, detail, page numbers, drawing numbers, and sheet numbers, etc. The Contractor shall make suggestions and/or interpretations of the issue raised by the RFI. An RFI cannot modify the Contract Cost, Contract Time, or the Contract Documents.
- C. The Architect must respond to a RFI within fourteen (14) calendar days after receiving such request. If the Architect cannot respond to the RFI within fourteen (14) calendar days, the Architect shall notify the Contractor, with a copy to the Inspector and the Owner, of the amount of time that will be required to respond.
- D. The Contractor shall be invoiced by the Owner for any costs incurred for professional services, which shall be deducted from the next progress payment, if an RFI requests an interpretation or decision of a matter where the information sought is equally available to the party making such request.

1.06 ARCHITECT'S SUPPLEMENTAL INSTRUCTIONS ("ASI")

- A. An ASI is a written supplemental instruction issued and signed by the Architect for minor changes to the Work, without change in Contract Sum or Contract Time.
- B. Architect Authority;
 - 1. The Architect will have authority to order minor changes in the Work not involving any adjustment in the Contract Sum, an extension of the Contract Time, or a change which is inconsistent with the intent of the Contract Documents.
 - 2. Such changes shall be effected by written Change Order and shall be binding on the Owner and the Contractor. The Contractor shall carry out such written orders promptly.

1.07 REQUEST FOR PROPOSAL ("RFP")

- A. An RFP is a written request prepared by the Architect asking the Contractor to submit to the Owner and the Architect an estimate of the effect of a proposed change on the Contract Price and the Contract Time.
- B. An RFP shall contain adequate information, including any necessary drawings and specifications, to enable Contractor to provide the cost breakdowns.

- C. Owner or Architect may initiate changes by submitting a proposal request to Contractor. Request will include:
 - 1. Detailed description of the change, products and location of the change in the project.
 - 2. Supplementary or revised drawings and specifications.
 - 3. The projected time span for making the change and a specific statement as to whether overtime work is, or is not, authorized.
 - 4. A specific period of time during which the requested price will be considered valid.
 - 5. Such request is for information only and is not an instruction to execute the changes nor to stop work in progress.

- D. The Contractor shall not be entitled to any Additional Compensation for preparing a response to an RFP, whether ultimately accepted or not.

1.08 CHANGE ORDER REQUEST ("COR")

- A. Refer to General Conditions.

1.09 CHANGE ORDERS ("CO")

- A. No Changes Without Authorization;
 - 1. There shall be no change whatsoever in the drawings, specifications, or in the Work without an executed Change Order or an order by the Architect for a minor change in the Work as herein provided.
 - 2. Owner shall not be liable for the cost of any extra work or any substitutions, changes, additions, omissions, or deviations from the Drawings and Specifications unless the same shall have been authorized by and the cost thereof approved in writing by Change Order.
 - 3. No extension of time for performance of the Work shall be allowed hereunder unless claim for such extension is made at the time changes in the Work are ordered, and such time duly adjusted in writing in the Change Order.
 - 4. The provisions of the Contract Documents shall apply to all such changes, additions, and omissions with the same effect as if originally embodied in the Drawings and Specifications.
 - 5. Notwithstanding anything to the contrary in this Article, all Change Orders shall be prepared and issued by the Architect and shall become effective when executed by the Owner, the Architect, the Contractor, and associated Construction Change Document (CCD) approved by DSA.

- B. Owner will designate in writing the person who is authorized to execute change orders.

- C. Contractor may initiate changes by submitting a written notice to Architect containing:
 - 1. Description of the proposed changes.
 - 2. Statement of the reason for making the changes.
 - 3. Statement of the effect on the contract sum and the contract time.
 - 4. Statement of the effect on the work of separate contractors.
 - 5. Documentation supporting any change in contract sum or contract time as appropriate.

- D. A Change Order is a written instrument prepared by the Architect and signed by the Owner, the Contractor, and the Architect stating their agreement upon all of the following:
 - 1. a change in the Work;
 - 2. the amount of the adjustment in the Contract Sum, if any; and

3. the extent of the adjustment in the Contract Time, if any.
- E. The following paragraph shall be a part of each Change Order:
1. The compensation (time and cost) set forth in this Change Order comprises the total compensation due the Contractor, all Subcontractors and all Suppliers, at all tiers, for the work or change defined in the Change Order, including all impact on unchanged work. By signing this Change Order the Contractor acknowledges and agrees, on behalf of themselves, all Subcontractors and all Suppliers, at all tiers, that the stipulated compensation includes payment for all work contained in the Change Order, plus all payment for the interruption of schedules, extended and unabsorbed overhead costs, delay, disruption, and all impact, ripple impact or cumulative impact on all other work under this Contract. The signing of the Change Order indicates that the Change Order constitutes full mutual accord and satisfaction for the changed work, and that the time and cost under the Change Order constitutes the total equitable adjustment owed the Contractor, all Subcontractors and all Suppliers, at all tiers, as a result of the change. The Contractor, on behalf of themselves, all Subcontractors and all Suppliers, at all tiers, agrees to waive all rights, without exception or reservation of any kind whatsoever to file any further claim related to this Change Order. No further claim or request for equitable adjustment of any kind whatsoever shall arise out of or as a result of this change or the impact of this change on the remainder of the work under this Contract.
- F. For a "close out" Change Order (i.e., the final Change Order on the project), add the following paragraph.
1. By execution of this Change Order the Contractor specifically waives, relinquishes, and releases any and all rights under Section 1542 of the California Civil Code which reads as follows:

"A GENERAL RELEASE DOES NOT EXTEND TO CLAIMS WHICH THE CREDITOR DOES NOT KNOW OR SUSPECT TO EXIST IN HIS OR HER FAVOR AT THE TIME OF EXECUTING THE RELEASE, WHICH IF KNOWN BY HIM OR HER MUST HAVE MATERIALLY AFFECTED HIS OR HER SETTLEMENT WITH THE DEBTOR."

1.10 EXECUTION OF CHANGE ORDERS

- A. Execution of Change Orders: Architect/Engineer will issue Change Orders for signatures of parties as provided in the Conditions of the Contract.
- B. Transmittal and Distribution:
 1. Architect will prepare and execute the Change Order and forward to Contractor.
 2. Contractor shall execute the Change Order and forward to Architect. Architect will forward Change Order to Owner.
 3. Owner will execute the Change Order and forward to the Architect.

1.11 CORRELATION OF CONTRACTOR SUBMITTALS

- A. Promptly revise Schedule of Values and Application for Payment forms to record each authorized Change Order as a separate line item and adjust the Contract Sum/Price.
- B. Promptly revise progress schedules to reflect any change in Contract Time, revise sub-schedules to adjust times for other items of work affected by the change, and resubmit.
- C. Promptly enter changes in Project Record Documents.

PART 2 PRODUCTS

Not Used.

PART 3 EXECUTION

3.01 ELECTRONIC PROCESSING PROCEDURES

- A. Modification requests shall be transmitted to the Architect using the project's cloud-based file sharing and storage service ("project's website") with electronic, editable (PDF) format attachments, as required. The cloud-based file sharing and storage service will be selected by the Architect. Contractor's failure to utilize, provide entries and processing through the Architect's cloud-based system will subject Contractor to hourly back charges associated with efforts required by others to perform work which is the contractual responsibility of the Contractor.
- B. Contractor's cost related to use of the project's website services shall be included in the Contractor's bid.
- C. Provide hardcopy submittals if requested by Architect.
- D. The Architect's review comments and/or direction will be made available on the project's website for downloading.
- E. Contractor will distribute a hardcopy of all reviewed request and direction to the Inspector of Record, Owner, and Construction Manager.

END OF SECTION

(MODIFICATION PROCEDURE FORMS FOLLOW)

REQUEST FOR INFORMATION
ARCHITECT'S SUPPLEMENTAL INSTRUCTIONS
REQUEST FOR PROPOSAL
CHANGE ORDER



QUATTROCCHI KWOK
 ARCHITECTS

Request for Information

Detailed, RFIs without Routing Information Grouped by RFI Number

Project Number:
 DSA Application:
 DSA File:

| | | | Date Created: |
|---|-------------|-------------------|---------------|
| Answer Company | Answered By | Author Company | Authored By |
| Quattrocchi Kwok Architects 636 5th Street Santa Rosa, CA 95404 | | | |
| Co-Respondent | | Author RFI Number | |

| Subject | Discipline | Category | | |
|----------------------|------------|--------------------------|------|-------------------------|
| Cost Impact | Amount | Schedule Impact | Days | Drawing Impact |
| | | | 0 | |
| Cost Impact Comments | | Schedule Impact Comments | | Drawing Impact Comments |

Drawing/Specification Section Reference:

| Question | Date Required: |
|------------|----------------|
| Suggestion | |
| Answer | Date Answered: |

-O-1.5



Architect's Supplemental Instruction

Detailed, Grouped by Each Number

Project Number:
DSA Application:
DSA File:

Number: **Date:**

To: **From:** Quattrocchi Kwok Architects
636 5th Street
Santa Rosa, CA 95404

Subject

Reference Drawing/Detail **Attachments**

Description



-O-1.6

Request for Proposal

Project Number:
DSA Application:
DSA File:

RFP ____

Please submit an itemized proposal for changes in the Contract Sum or Contract Time for proposed modifications to the Contract Documents described herein. Submit proposal within ten (10) days or notify the Architect in writing of the date on which you anticipate submitting your proposal. Proposal shall include all impacts related to this change and contractor is due no further completion than represented by proposal for change or any impacts related to change.

THIS IS NOT A CHANGE ORDER OR A DIRECTION TO PROCEED WITH THE WORK DESCRIBED IN THE PROPOSED MODIFICATIONS.

Please provide itemized pricing for the following description of work:

Attachments:

CHANGE ORDER

| | |
|---|-----------------|
| | Distribution to |
| X | OWNER |
| X | ARCHITECT |
| X | CONTRACTOR |
| X | IOR (copy) |
| X | ORS |
| | |

298 - O - 1.8
CO
00

P:\298.97 - Rincon Valley ES (Skyhawk)\FILES\I-OR-1.S\298-CO.XLS

PROJECT

Change Order No. Zero (00)

Project No.
 Initiation Date:
 Contract For:
 Contract Date
 ORS File No.
 ORS App. No.
 OPSC App. No.

CONTRACTOR

You are directed to make the following changes in this contract: (Refer to Attached Summary)

Reserved for Architect's Stamp

Reserved for DSA/ORS Approval Stamp

| | |
|---|-------|
| The original Contract Sum was | _____ |
| Net change by previous Change Orders | _____ |
| The Contract Sum prior to this Change Order was | _____ |
| The Contract Sum will be UNCHANGED by this Change Order in the amount of | _____ |
| The new Contract Sum including this Change Order will be | _____ |
| The Contract Time will be UNCHANGED by this Change Order in the amount of | _____ |
| The Date of Completion as of the date of this Change Order: | _____ |

Not valid until signed by both the Owner and the Architect.

Signature of the contractor indicates his approval herewith, including any adjustment in the Contract Sum or Contract Time.

The compensation (time and cost) set forth in this Change Order comprises the total compensation due the Contractor, all Subcontractors and all Suppliers, at all tiers, for the work or change defined in the Change Order, including all impact on unchanged work. By signing this Change Order the Contractor acknowledges and agrees, on behalf of themselves, all Subcontractors and all Suppliers, at all tiers, that the stipulated compensation includes payment for all work contained in the Change Order, plus all payment for the interruption of schedules, extended and unabsorbed overhead costs, delay, disruption, and all impact, ripple impact or cumulative impact on all other work under this Contract. The signing of the Change Order indicates that the Change Order constitutes full mutual accord and satisfaction for the changed work, and that the time and cost under the Change Order constitutes the total equitable adjustment owed the Contractor, all Subcontractors and all Suppliers, at all tiers, as a result of the change. The Contractor, on behalf of themselves, all Subcontractors and all Suppliers, at all tiers, agrees to waive all rights, without exception or reservation of any kind whatsoever to file any further claim related to this Change Order. No further claim or request for equitable adjustment of any kind whatsoever shall arise out of or as a result of this change or the impact of this change on the remainder of the work under this Contract.

By execution of this Change Order the Contractor specifically waives, relinquishes, and releases any and all rights under Section 1542 of the California Civil Code which reads as follows:

"A GENERAL RELEASE DOES NOT EXTEND TO CLAIMS WHICH THE CREDITOR DOES NOT KNOW OR SUSPECT TO EXIST IN HIS FAVOR AT THE TIME OF EXECUTING THE RELEASE, WHICH IF KNOWN BY HIM MUST HAVE MATERIALLY EFFECTED HIS SETTLEMENT WITH THE DEBTOR."

| | | |
|---------------------------------------|-------------------|--------------|
| ARCHITECT | CONTRACTOR | OWNER |
| QUATTROCCHI KWOK ARCHITECTS | | |
| 636 Fifth St. Santa Rosa, CA 95404 | | |
| By. _____ | By. _____ | By. _____ |
| Date _____ | Date _____ | Date _____ |

SUMMARY OF ATTACHMENTS TO:
 PROJECT
 0
 0

Change Order No. Zero (00)
 Project No. _____
 Contract For: _____
 ORS App. No. _____

The Time for Milestone 1 will be UNCHANGED by this Change Order in the amount of _____
 The Date of Milestone 1 as of the date of this Change Order therefore is _____
 The Time for Milestone 2 will be UNCHANGED by this Change Order in the amount of _____
 The Date of Milestone 2 as of the date of this Change Order therefore is _____

| No. | Reference: | Description: | C.O.R. # | Request by: | Amount | Calendar Days Added to Contract | | | | |
|----------------|------------|--------------|----------|-------------|--------|------------------------------------|----|----|----|---|
| | | | | | | DoC | M1 | M2 | M3 | |
| TOTALS: | | | | | \$ | - | 0 | 0 | 0 | 0 |
| 1. | | | | | | | | | | |
| 2. | | | | | | | | | | |
| 3. | | | | | | | | | | |
| 4. | | | | | | | | | | |
| 5. | | | | | | | | | | |
| 6. | | | | | | | | | | |
| 7. | | | | | | | | | | |
| 8. | | | | | | | | | | |
| 9. | | | | | | | | | | |
| 10. | | | | | | | | | | |
| 11. | | | | | | | | | | |
| 12. | | | | | | | | | | |
| 13. | | | | | | | | | | |
| 14. | | | | | | | | | | |
| 15. | | | | | | | | | | |
| 16. | | | | | | | | | | |
| 17. | | | | | | | | | | |
| 18. | | | | | | | | | | |
| 19. | | | | | | | | | | |
| 20. | | | | | | | | | | |
| 21. | | | | | | | | | | |
| 22. | | | | | | | | | | |
| 23. | | | | | | | | | | |
| 24. | | | | | | | | | | |
| 25. | | | | | | | | | | |
| 26. | | | | | | | | | | |
| 27. | | | | | | | | | | |
| 28. | | | | | | | | | | |
| 29. | | | | | | | | | | |
| 30. | | | | | | | | | | |
| 31. | | | | | | | | | | |
| 32. | | | | | | | | | | |
| 33. | | | | | | | | | | |
| 34. | | | | | | | | | | |
| 35. | | | | | | | | | | |
| END OF SUMMARY | | | | | | | | | | |

SECTION 01 3300

SUBMITTALS

PART 1 GENERAL

1.01 SECTION INCLUDES

- A. Submittals required by the Contract Documents. Revise and re-submit as necessary to establish compliance with Contract Documents.
 - 1. It is reasonable that the Contractor will provide a satisfactory submittal by the second submittal. If repeated resubmittals are required, the Owner may "back charge" the Contractor for the cost of review and processing.

1.02 WORK NOT INCLUDED

- A. Submittals which are not required will not be reviewed by the Architect.
- B. The Contractor may require subcontractors to provide drawings, setting diagrams or similar information as part of the coordination of the Work. The Architect will not review this data.

1.03 RELATED WORK

- A. Section 01 3100 - Construction Schedules: Dates for submission and dates that reviewed submittals will be required shall be designated in the Construction Schedule.
- B. Section 01 7000 - Contract Closeout: Project record documents.

1.04 QUALITY ASSURANCE

- A. Submit to the Architect for review, product literature, samples and shop drawings as specified or required to fully describe every item proposed for incorporation in the work. Only approved items may be used.
- B. Prior to submittal, review and coordinate all aspects of each item. Verify that each item and it's submittals conform to Contract Document requirements. Contractor assumes full responsibility for coordinating and verifying information, quantities and dimensions shown in submittals.
- C. Submittals shall include:
 - 1. Date and revision dates.
 - 2. Project title and number.
 - 3. The names of:
 - a. Architect/Engineer.
 - b. Contractor.
 - c. Subcontractor.
 - d. Supplier.
 - e. Manufacturer.
 - f. Separate detailer when pertinent.
 - 4. Identification of product or material.

5. Relation to adjacent structure or materials.
 6. Field dimensions, clearly identified as such.
 7. Specification section number.
 8. Applicable standards, such as ASTM number or Federal Specification.
 9. A blank space, 8 inches x 3 inches, for the Contractor and Architect stamps.
 10. Identification of deviations from Contract Documents.
 11. Contractor's stamp, initialed or signed, certifying to review of submittal, verification of field measurements and compliance with Contract Documents.
 12. Signature of and calculations by an engineer, licensed in California, where required by specifications.
- D. Indicate review and approval of each submittal prior to transmittal to Architect by affixing Contractor's stamp, initialed or signed, certifying:
1. Review of submittal
 2. Verification of compliance with requirements of the Contract Documents.
 3. Verification of compatibility with other submittals, shop drawings, substitutions, and work of other trades.
 4. Coordination with existing job conditions and field construction criteria.
 5. Field verification of dimensions.
- E. Architect will review Contractor's stamp language. Revise language in accordance with Architect's comments and provide new stamp if required by Architect.
- F. Architect will return unreviewed any submittal not stamped by the Contractor in accordance with the above.
- G. Direct Architect's attention to any deviations from the Contract Documents . Deviations not so noted shall be considered unreviewed.
- H. Direct Architect's attention to any changes made in submittals other than those specifically requested by Architect. Changes not so noted shall be considered unreviewed.
- I. Work shall not be fabricated, nor material shipped to project site prior to the distribution of approved submittals from the Architect.

1.05 SUBMITTALS

- A. Make submittals of shop drawings, product data, samples, substitution requests, meeting minutes and other items required by the Contract Documents in accordance with the provisions of this Section.
- B. Submittals shall include all technical and performance data necessary for the Architect to properly evaluate the submittal. Provide physical samples if requested by Architect, whether expressly specified or not.
- C. Incomplete submittals will be return to the Contractor without review. Contractor shall be responsible for delays incurred by incomplete, multiple reviews or rejected submittals.
- D. Provide only one make or brand of any product proposed.

PART 2 PRODUCTS

2.01 SHOP DRAWINGS

- A. Shop drawings are to be drawn at large scale, fully detailed and with all materials and stock or purchased components fully identified. Shop drawings are to be submitted when specified and to illustrate every custom fabricated item or assembly.
- B. Types of prints required: See 3.01 ELECTRONIC SUBMITTAL PROCEDURES.
- C. Drawings are to be identified showing the project name, the Owner's name and account number, the Architect's name and job number, the Contractor's name and the specification section number and drawing detail reference number relating to the work shown.

2.02 PRODUCT DATA

- A. Submit detailed technical literature fully describing every product or item proposed for use including manufacturers and items specified. Include manufacturer's detailed specifications, drawings, photographs, performance criteria, installation instructions, test data, samples of colors and finishes and other information required to fully describe the item.
 - 1. Modify standard product data to delete information which is not pertinent.
 - 2. Provide additional information which is specifically applicable.
- B. Mark all submittals indicating items, options, and finishes proposed, and referencing project specification section and paragraph covering the work in question. Indicate as follows:
 - 1. Performance characteristics and capacities.
 - 2. Dimensions and/or clearances required.
 - 3. Wiring, piping and control diagrams.

2.03 SAMPLES

- A. Samples shall be identical to the precise article proposed, illustrating functional characteristics with all related parts and attachments. Indicate full range of color, textures and patterns.
- B. Samples shall be identified by attaching a label on unexposed side of Samples that include the following:
 - 1. Generic Description of Sample.
 - 2. Product name and name of manufacturer.
 - 3. Number and title of applicable Specification Section.
- C. Submit number of samples as indicated above. Where samples of large complete items such as light fixtures, hardware, etc. are required, one sample will suffice and that will be returned to the Contractor after review.

2.04 COLORS AND PATTERNS

- A. Submit color and pattern selections for all products offering a choice of these attributes unless a specific color or pattern is referenced in the Contract Documents.

- B. Submit within thirty five (35) days of Notice of Award a list of all required color selections organized by product, including manufacturer and model. Include samples of manufacturer's complete color range for all products.
- C. Architect will not select colors or patterns until samples of all items requiring selections have been submitted. Architect will not make partial color selections.
- D. Failure to submit all color selections as specified above, thus requiring additional unanticipated time for the Architect to make selections will not be basis for extension of Contract Time.
- E. Architect will make color selections within 30 working days following complete submittal of samples. This time will commence with the receipt of the latest incremental submittal, as applicable.
- F. Architect will issue Color Schedule.

PART 3 EXECUTION

3.01 ELECTRONIC SUBMITTAL PROCEDURES

- A. Submittals shall be transmitted to the Architect in electronic, editable (PDF) format using the project's cloud-based file sharing and storage service ("project's website"). The cloud-based file sharing and storage service will be selected by the Architect. Contractor's failure to utilize, provide entries and processing through the Architect's cloud-based system will subject Contractor to hourly back charges associated with efforts required by others to perform work which is the contractual responsibility of the Contractor.
- B. Contractor's cost related to the use of the project's website services shall be included in the Contractor's bid.
- C. The electronic submittal process is not intended for color samples, color charts, or physical material samples.
- D. For the shop drawings larger than 11' x 17' size and Deferred Approvals, submit (3) hardcopies to the Architect and also submit electronically on the project's website. Provide additional hardcopies, as requested by Architect.
- E. Provide hardcopy submittals if requested by Architect.
- F. The Architect's review comments will be made available on the project's website for downloading.
- G. Contractor will distribute a hardcopy of all reviewed submittals to the Inspector of Record, Owner, and Construction Manager.

3.02 ADMINISTRATION REQUIREMENTS

- A. Name electronic file using the following identifiers, separated by dashes: consecutive submittal number, specification section number, revision number (if needed), and a brief description of the submittal contents; example: 15-05 5000-0 Metal Fabrications.
- B. Write sequential page numbers at bottom of each page of submittal. On submittal cover sheet, provide brief description for product and coinciding page numbers; example: Pages 5-23 Metal Fabricated Gate Shop Drawings.
- C. Provide the following on the submittal cover sheet:
 1. Project title and project number.
 2. Date.
 3. Submittal number.
 4. The name of:
 - a. Architect/Engineer.
 - b. Contractor.
 - c. Subcontractor.
 - d. Supplier.
 - e. Manufacturer.
 - f. Separate detailer when pertinent.
 5. Identification of product or material and page numbers.
 6. Submittal number, as described in 3.03.
 7. A blank space, 8 inches x 3 inches, for the contractor and Architects stamps.
 8. Contractor's stamp, initialed or signed, certifying to review of submittal, verification of field measurements, and compliance with Contract Documents.
- D. Unless otherwise indicated in technical specifications, not less than 15 days following Notice of Award, submit a complete submittal register utilizing spreadsheet provided by Architect. The architect provided submittal register is a template including most potential submittal items. Contractor shall strike through any submittal items not intended for submittal and highlight any revisions or additions to the template provided. All columns of information shall be filled out in full. Contractor shall then return edited spreadsheet to Architect for review. Spreadsheet format must not be altered to allow insertion into project data base. Once reviews are complete, the Architect will upload the submittal register into the project data base for all party's utilization.

3.03 IDENTIFICATION OF SUBMITTALS

- A. Number submittals consecutively. Each specification section requiring submittal must at a minimum have one unique submittal number. DO NOT GROUP MULTIPLE SPECIFICATION SECTION ITEMS UNDER ONE SUBMITTAL NUMBER. Refer to submittal by this number in subsequent correspondence and submittals.
 1. Transmit re-submittals under new cover. Use submittal number of original submittal with revision number suffix. Cite original submittal number for reference.
 2. Do not transmit new submittals with alphabetic suffix.

- B. Transmittal letter for each submittal shall show all information required for identification and checking.
- C. Include submittal number on first page and elsewhere as required for identification.
- D. Maintain log of submittals and status. Furnish copies to the Architect and Inspector upon request.

3.04 GROUPING OF SUBMITTALS

- A. Transmit submittals in groups containing all associated items to ensure availability of information during review. However, each specification section must bear unique submittal number.
- B. Incomplete or partial submittals may be returned for enhancement. No extension of time will be allowed for delays related to incomplete submittals.

3.05 SCHEDULING OF SUBMITTALS

- A. Transmit submittals sufficiently in advance of installation for required review, revisions, re-submittals and delivery. Include time required for transmittal by regular mail between the parties involved. No extension of time will be allowed for delays related to late submittals.
- B. Deferred approval submittals are subject to long lead times. Schedule submittals accordingly.

3.06 ARCHITECT'S REVIEW OF SUBMITTALS

- A. Submittals will be reviewed and stamped by the Architect "No exceptions taken," "Submit specified item" or "Make corrections noted" to indicate full or conditioned approval or "Revise and resubmit" or "Rejected" to indicate disapproval. Terms are defined as follows:
 - 1. No Exceptions Taken: Accepted subject to its compatibility with future submittals and additional partial submittals for portions of the work not covered in this submittal. Does not constitute approval or deletion of specified or required items not shown in the partial submittal.
 - 2. Submit specified item: Submit to the Architect the items indicated for review.
 - 3. Correct as noted: Same as 1., except that minor corrections as noted shall be made by the Contractor. No resubmittal required.
 - 4. Revise and resubmit: Rejected because of major inconsistencies or errors which shall be resolved or corrected by the Contractor prior to subsequent review by the Architect.
 - 5. Rejected: Submitted material does not conform to plans and specifications in major respect. For example, wrong size, model, capacity or material. Resubmit.
 - 6. Receipt Acknowledged. Received, recorded and distributed without further action.
- B. Submittals reviewed by the Architect which have been stamped shall be deemed to have the following language affixed and made a part thereof, regardless of the initial or subsequent readability of the actual stamp.

1. Corrections or comments made on submittals during this review do not relieve the contractor from compliance with the requirements of the drawings and specifications. This check is for review of general conformance with the design concept of the project and general compliance with information given in the Contract Documents. The contractor is responsible for confirming and correlating all quantities and dimensions, selection of fabrication processes and techniques of construction, coordinating the work of the trades; and performing the work in a safe and satisfactory manner.
- C. Architect's review of submittals shall be undertaken with reasonable promptness, while allowing sufficient time in the Architect's professional judgment to permit adequate review.
 - E. Architect's review of submittals has, as a primary objective, to assist in the completion of the project on time and in conformance with the Contract requirements by permitting review of material and fabricated items prior to ordering. Architect's review of submittals is based only on the data presented and extends only to conformance with general design intent and information contained in the Contract Documents.
 - E. Architect's approval of submittals does not constitute final acceptance or unqualified approval of items or work proposed or put in place, nor does it constitute acceptance of responsibility for the accuracy, coordination or completeness of submittals. Architect's approval of submittals does not relieve the Contractor from the responsibility for errors, omissions, or compliance with all the requirements of the Contract Documents.
 - F. Reimbursement of the Architect's costs for review:
 1. Architect will record all time and expenses incurred to review submittals requiring more than two reviews.
 2. Contractor shall reimburse the District through deduction from amounts due the Contractor upon receipt of the Architect's billing and that of the Architect's consultants at standard billing rates for all time and expenses incurred in unanticipated reviews.
 - G. Architect's review of submittals does not change the Contract in any manner.

3.07 RESUBMITTAL

- A. Make all corrections or revisions required by reviewer's comments at Contractor's expense and resubmit as initially specified above. No additional costs will be authorized for corrections or revisions.
- B. Product data and shop drawings:
 1. Revise initial drawings or data and resubmit as initially specified.
 2. Indicate changes which have been made other than those requested by reviewer.
- C. Submit new samples as initially specified.

3.08 DEFERRED APPROVAL

- A. Items so designated in the Contract Documents are subject to deferred approval review by the Division of the State Architect (DSA).

- B. Not less than 15 days following Notice of Award, submit all items specified for deferred approval complete with all structural calculations, test data and information as specified or as subsequently required by the reviewing agency, including original engineering stamps and original signatures as required. Architect shall submit to DSA only following Architect/Engineer review.
 - 1. The Architect will not approve deferred approval submittals until they are approved by DSA.
- C. No work or fabrication shall begin until DSA approved submittals are distributed to the Contractor.
- D. Contractor is notified that significant lead time is required for deferred approval review by DSA and shall schedule work accordingly. No extension of Contract Time will be allowed for delays incurred by deferred approval review.
 - 1. The Architect is not responsible for DSA delays in deferred approval review.

3.09 DISTRIBUTION

- A. Distribute only submittals with Architect/Engineer (and DSA as applicable) stamps of review. Contractor is responsible for coordination of submittals and comments following review. Contractor to provide all additional reproduction costs for copies required by the Contractor at its expense. No additional costs will be authorized for Contractor costs pertaining to submittals.

END OF SECTION

SECTION 01 3546

CONSTRUCTION INDOOR AIR QUALITY MANAGEMENT PLAN

PART 1 - GENERAL

1.01 RELATED DOCUMENTS

- A. Drawings and general provisions of the Contract, including General and Supplementary Conditions and other Division 01 specification sections, apply to this section.

1.02 SECTION INCLUDES

- A. Description of a construction Indoor Air Quality (IAQ) Management Plan.
- B. IAQ construction requirements.

1.03 RELATED SECTIONS

- A. Section 01 6116 - VOC Restrictions.
- B. Section 23 0593 - Testing, Adjusting, and Balancing for HVAC: Additional requirements for baseline testing for IAQ.
- C. Section 23 0593- Testing, Adjusting, and Balancing for HVAC: Cleaning of HVAC system including ductwork, air intakes and returns, and changing of filters.

1.04 REFERENCES

- A. American Society of Heating, Refrigerating and Air-Conditioning Engineers, Inc. (ASHRAE):
 - 1. ASHRAE Standard 52.1-1992, Gravimetric and Dust Spot Procedures for Testing Air Cleaning Devices in General Ventilation for Removing Particulate Matter.
- B. ASTM International (ASTM):
 - 1. ASTM D5116-97, Standard Guide for Small-Scale Environmental Chamber Determinations of Organic Emissions from Indoor Materials/Products.
- C. Sheet Metal and Air Conditioning National Contractors Association (SMACNA):
 - 1. IAQ Guidelines for Occupied Buildings under Construction, 1995.

1.05 INDOOR AIR QUALITY

- A. Goals: The Owner has set the following indoor air quality goals for jobsite operations on the project, within the limits of the construction schedule, Contract Sum, and available materials, equipment, products and services. Goals include:
 - 1. Protect workers on the site from undue health risks during construction.
 - 2. Prevent residual problems with indoor air quality in the completed building.

1.06 SUBMITTALS

- A. Indoor Air Quality Plan: Within 14 days after receipt of Notice to Proceed and prior to any waste removal from the project, develop and submit for review a healthy indoor air quality plan. The plan shall include:
 - 1. List of IAQ protective measures to be instituted on the site.
 - 2. Schedule for inspection and maintenance of IAQ measures.

1.07 QUALITY ASSURANCE

- A. Perform material tests and report results in accordance with ASTM D5116.

PART 2 - PRODUCTS

2.01 SUBSTITUTIONS

- A. Should the Contractor desire to use procedures, materials, equipment, or products that are not specified but meet the intent of the specifications to protect indoor air quality on the site, the Contractor shall propose these substitutions in accordance with Section 01 6000.

2.02 MATERIALS

- A. Low emitting products have been specified in appropriate sections.

PART 3 - EXECUTION

3.01 CONSTRUCTION IAQ MANAGEMENT PLAN

- A. Meet or exceed the minimum requirements of the Sheet Metal and Air Conditioning National Contractors Association (SMACNA) "IAQ Guidelines for Occupied Buildings Under Construction."
 - 1. Protect the ventilation system components from contamination, OR provide cleaning of the ventilation components exposed to contamination during construction prior to occupancy.
 - 2. Provide a continuous ventilation rate of one (1) air change per hour minimum during construction, OR, conduct a building flush-out with new filtration media at 100 percent outside air after construction ends (following issuance of a Certificate of Occupancy) and prior to occupancy for seven (7) days. Provide a minimum of 85 percent filtration (as determined by ASHRAE Standard 52.1 on any return air systems that are operational during construction, and replace filtration media prior to occupancy.
- B. During installation of carpet, paints, furnishings, and other VOC-emitting products, provide supplemental (spot) ventilation for at least 72 hours after work is completed. Preferred HVAC system operation uses supply air fans and ducts only; exhaust provided through windows. Use exhaust fans to pull exhaust air from deep interior locations. Stair towers and other paths to exterior can be useful during this process.
- C. Conduct regular inspection and maintenance of indoor air quality measures including ventilation system protection, and ventilation rate.
- D. Require VOC-safe masks for workers installing VOC-emitting products (interior and exterior) defined as products that emit 150 gpl or more UNLESS local jurisdiction's requirements are stricter, in which case the strictest requirements shall be followed for use of VOC-safe masks.

- E. Use low-toxic cleaning supplies for surfaces, equipment, and worker's personal use. Options include several soybean-based solvents and cleaning options (SOYsolv) and citrus-based cleaners.

- F. Use wet sanding for gypsum board assemblies. Exception: Dry sanding allowed subject to Architect's approval of the following measures:
 - 1. Full isolation of space undergoing finishing.
 - 2. Plastic protection sheeting is installed to provide air sealing during sanding.
 - 3. Closure of all air system devices and ductwork.
 - 4. Sequencing of construction precludes the possibility of contamination of other spaces with gypsum dust.
 - 5. Worker protection is provided.

- G. Use safety meetings, signage, and [sub] contractor agreements to communicate the goals of the construction indoor air quality plan.

END OF SECTION

SECTION 01 3900

COORDINATION AND MEETINGS

PART 1 GENERAL

1.01 SECTION INCLUDES

- A. Coordination and project conditions.
- B. Related work.
- C. Discrepancies.
- D. Examination.
- E. Pre-Contract meeting.
- F. Pre-construction meeting.
- G. Site mobilization meeting.
- H. Progress meetings.
- I. Pre-installation meetings.
- J. Project coordination meetings.

1.02 COORDINATION AND PROJECT CONDITIONS

- A. Coordinate scheduling, submittals, and Work of the various portions of the Contract Documents to assure efficient and orderly sequence of installation of interdependent construction elements.
- B. Coordinate hours and days of Work with local ordinances and requirements.
- C. Verify utility requirements and characteristics of operating equipment are compatible with building utilities. Coordinate work of various sections having interdependent responsibilities for installing, connecting to, and placing in service, such equipment.
- D. Coordinate space requirements, supports, and installation of mechanical and electrical Work which are indicated diagrammatically on Drawings. Follow routing shown for pipes, ducts, and conduit, as closely as practicable; place runs parallel with lines of building. Utilize spaces efficiently to maximize accessibility for other installations, for maintenance, and for repairs.
- E. In finished areas except as otherwise indicated, conceal pipes, ducts, and wiring within the construction. Coordinate locations of fixtures and outlets with finish elements.

- F. Coordinate completion and clean up of Work of separate sections in preparation for Substantial Completion.
- G. After Owner occupancy of premises, coordinate access to site for correction of defective Work and Work not in accordance with Contract Documents, to minimize disruption of Owner's activities.
- H. Contractor shall coordinate Work with work to be performed by separate contractors as listed in Section 01 1100 - Summary of Work.

1.03 RELATED WORK

- A. Referencing specification sections in "Related Work" articles is for convenience only and shall not be construed as to limit the coordination of the Contract Documents to referenced sections.
- B. Documents affecting the work of any section include, but are not limited to, General Conditions, Supplementary General Conditions, and Sections in Division 01 of these Specifications.
- C. Work in any section may relate to other work in these documents. The Contractor is responsible to coordinate all work.

1.04 DISCREPANCIES

- A. In the event of discrepancy in the Contract Documents or if uncovered conditions are not as anticipated, immediately notify the Architect and secure needed direction.
- B. Do not proceed in areas of discrepancy until such discrepancies have been fully resolved.
- C. Before starting work, verify governing dimensions at the premises, and examine adjoining work on which this work is dependent. No "Extra" or additional compensation will be allowed on account of differences between actual measurements and dimensions shown. Submit differences discovered during the work to Architect for interpretation before proceeding with the associated work.
- D. Any time extension or any increase or decrease of cost resulting from such changes will be adjusted in the manner provided in the General Conditions.

1.05 EXAMINATION

- A. Verify that existing site conditions and substrate surfaces are acceptable for subsequent Work.
Beginning new Work means acceptance of existing conditions.
- B. Examine and verify specific conditions described in individual specification sections.
- C. Verify that utility services are available, of the correct characteristics, and in the correct location.

1.06 PRE CONTRACT MEETING

- A. Architect will schedule a meeting with District and apparent low bidder prior to award of Contract.

- B. Attendance Required: Owner, Architect, and Contractor.
- C. Agenda: Execution of the Notice of Award, Review of documents required for Preconstruction Meeting.

1.07 PRECONSTRUCTION MEETING

- A. Architect will schedule a meeting after Notice of Award.
- B. Attendance Required: Owner, Architect and Contractor.
- C. Agenda:
 - 1. Execution of Owner-Contractor Agreement.
 - 2. Submission of executed bonds and insurance certificates.
 - 3. Distribution of Contract Documents.
 - 4. Submission of schedule of values.
 - 5. Designation of personnel representing the parties in Contract, and the Architect/Engineer.
 - 6. Procedures and processing of field decisions, submittals, substitutions, applications for payments, proposal request, Change Orders, and Contract closeout procedures.
 - 7. Scheduling.
 - 8. Scheduling activities of DSA Inspector of Record.
- D. Architect will record minutes and distribute copies within five days after meeting to participants, and those affected by decisions made.

1.08 SITE MOBILIZATION MEETING

- A. Architect will schedule a meeting at the Project site prior to Contractor occupancy.
- B. Attendance Required: Owner, Architect, Special Consultants, Contractor, Contractor's Superintendent and major Subcontractors.
- C. Agenda:
 - 1. Use of premises by Owner and Contractor.
 - 2. Owner's requirements and partial occupancy.
 - 3. Construction facilities and controls provided by Owner.
 - 4. Temporary utilities provided by Owner.
 - 5. Security and housekeeping procedures.
 - 6. Schedules.
 - 7. Application for payment procedures.
 - 8. Procedures for testing.
 - 9. Procedures for maintaining record documents.
 - 10. Requirements for start-up of equipment.
 - 11. Inspection and acceptance of equipment put into service during construction period.
- D. Architect will record minutes and distribute copies within five days after meeting to participants, and those affected by decisions made

1.09 PROGRESS MEETINGS

- A. Schedule and administer meetings throughout progress of the Work at bi-weekly intervals. Provide and discuss "two-week look ahead" schedule reports at these progress meetings. Coordinate progress payments and revised schedule, to monthly meeting attended by an officer of the construction company.
- B. Make arrangements for meetings, prepare agenda with copies for participants and preside at meetings.
- C. Attendance Required: Job Superintendent, major Subcontractors and suppliers, Owner, Inspector of Record and Architect as appropriate to agenda topics for each meeting.
- D. Architect will record minutes and distribute copies within five days after meeting to participants, including Owner, Contractor, and those affected by decisions made.

1.10 PREINSTALLATION MEETING

- A. When required in individual specification sections, convene a pre-installation meeting at the site prior to commencing work of the section.
- B. Require attendance of parties directly affecting, or affected by, work of the specific section.
- C. Notify Architect four days in advance of meeting date.
- D. Prepare agenda and preside at meeting:
 - 1. Review conditions of installation, preparation and installation procedures.
 - 2. Review coordination with related work.
- E. Architect will record minutes and distribute copies within five days after meeting to participants, with copies to Owner, Contractor and participants.

1.11 PROJECT COORDINATION MEETINGS

- A. Contractor will schedule project coordination meetings to be held weekly.
- B. Attendance Required: Contractor, job superintendent, Subcontractors, as required.
- C. Contractor will prepare agenda and preside at meeting.
- D. Contractor will record minutes and distribute copies within five days after meeting to participants, Architect and those affected by decisions made.
- E. Copies of the minutes to Architect are required as part of submission of Application for Payment.

PART 2 PRODUCTS

Not Used.

PART 3 EXECUTION

Not Used.

END OF SECTION

SECTION 01 4000
QUALITY CONTROL

PART 1 GENERAL

1.01 SECTION INCLUDES

- A. Quality assurance - control of installation.
- B. Tolerances.
- C. References.
- D. Mockup.
- E. Inspecting and testing laboratories services.
- F. Manufacturers' field services and reports.
- G. Field engineering and staking.

1.02 RELATED SECTIONS

- A. Section 01 4200- Reference Standards.
- B. Section 01 3300 - Submittals: Submission of manufacturers' instructions and certificates.
- B. Section 01 4523 - Testing and Inspection Services.
- C. Section 09 0512 - Concrete Floor Moisture Content & pH Testing.
- E. Section 01 6000 - Material, Equipment and Substitutions: Requirements for material and product quality.

1.03 QUALITY ASSURANCE - CONTROL OF INSTALLATION

- A. Monitor quality control over suppliers, manufacturers, Products, services, site conditions, and workmanship, to produce Work of specified quality.
- B. Correct conditions or workmanship not in conformance with specified standards or quality.
- C. Comply with manufacturers' instructions, including each step in sequence.
- D. Should manufacturers' instructions conflict with Contract Documents, request clarification from Architect/Engineer before proceeding.

- E. Comply with specified standards as minimum quality for the Work except where more stringent tolerances, codes, or specified requirements indicate higher standards or more precise workmanship.
- F. Perform Work by persons qualified to produce required and specified quality.
- G. Secure Products in place with positive anchorage devices designed and sized to withstand stresses, vibration, physical distortion, or disfigurement.

1.04 TOLERANCES

- A. Monitor tolerance control of installed Products to produce acceptable Work. Do not permit tolerances to accumulate.
- B. Comply with manufacturers' tolerances. Should manufacturers' tolerances conflict with Contract Documents, request clarification from Architect/Engineer before proceeding.
- C. Adjust Products to appropriate dimensions; position before securing Products in place.

1.05 REFERENCES

- A. For Products or workmanship specified by association, trade, or other consensus standards, comply with requirements of the standard, except when more rigid requirements are specified or are required by applicable codes.
- B. Conform to reference standard by date of issue current on date of Contract Documents, except where a specific date is established by code.
- C. Obtain copies of standards where required by product specification sections.
- D. The contractual relationships, duties, and responsibilities of the parties in Contract or those of the Architect/Engineer shall not be altered from the Contract Documents by mention or inference otherwise in any reference document.

1.06 MOCK-UP

- A. Tests will be performed under provisions identified in this section and identified in the respective product specification sections.
- B. Assemble and erect specified items with specified attachment and anchorage devices, flashings, seals, and finishes.
- C. Accepted mock-ups are representative of the quality required for the Work.
- D. Where mock-up has been accepted by Architect/Engineer and is specified in product specification sections to be removed; remove mock-up and clear area when directed to do so.

1.07 TESTING AND INSPECTION AGENCY SERVICES

- A. Owner will appoint, employ, and pay for specified services of an independent Testing and Inspection Agency to perform inspecting and testing. Inspections and Testing will be performed in accordance with Section 01 4523 - Testing and Inspection Services; and the General Conditions.

1.08 MANUFACTURERS' FIELD SERVICES

- A. When specified in individual specification sections, require material or Product suppliers or manufacturers to provide qualified staff personnel to observe site conditions, conditions of surfaces and installation, quality of workmanship and to initiate instructions when necessary.

1.09 FIELD ENGINEERING AND STAKING

- A. Each Contractor awarded Work for this Project shall provide all necessary surveying, layout, lines and grades required for the proper location of the Work.
- B. Contractor agrees to provide any and all false-work, templates, batter-boards and other such structures or devices necessary to provide for the Contractor's layout, lines and grades. Work installed in an incorrect location or elevation shall be removed and re-installed at the expense of the Contractor.

PART 2 PRODUCTS

Not Used.

PART 3 EXECUTION

Not Used.

END OF SECTION

SECTION 01 4200

REFERENCE STANDARDS

PART 1 GENERAL

1.01 RELATED DOCUMENTS

- A. Drawings and general provisions of contract, including General and Supplementary Conditions and other Division 01 Specification sections, apply to work of this section.

1.02 DESCRIPTION OF REQUIREMENTS

- A. General: This section specifies procedural and administrative requirements for compliance with governing regulations and the codes and standards imposed upon the work. These requirements include the obtaining of permits, licenses, inspections, releases and similar documentation, as well as payments, statements and similar requirements associated with regulations, codes, and standards.
 - 1. "Regulations" is defined to include laws, statutes, ordinances and lawful orders issued by governing authorities, as well as those rules, conventions and agreements within the construction industry which effectively control the performance of the work regardless of whether they are lawfully imposed by governing authority or not.
- B. Governing Regulations: Refer to General and Supplementary Conditions for requirements related to compliance with governing regulations.

1.03 DEFINITIONS

- A. General Explanation: A substantial amount of specification language constitutes definitions for terms found in other contract documents, including the drawings. (Drawings must be recognized as diagrammatic in nature and not completely descriptive of the requirements indicated thereon.) Certain terms used in contract documents are defined in this article. Definitions and explanations of this section are not necessarily either complete or exclusive, but are general for the work to the extent they are not stated more explicitly in another element of contract documents.
- B. General Requirements: The provisions or requirements of Division 01 sections apply to entire work of Contract and, where so indicated, to other elements which are included in project.
- C. Indicated: The term "indicated" is a cross-reference to graphic representations, notes or schedules on drawings, to other paragraphs or schedules in the specifications, and to similar means of recording requirements in contract documents. Where terms such as "shown," "noted," "scheduled," and "specified" are used in lieu of "indicated," it is for purpose of helping reader locate cross-reference, and no limitation of location is intended except as specifically noted.

- D. Directed, Requested, Etc.: Where not otherwise explained, terms such as "directed," "requested," "authorized," "selected," "approved," "required," "accepted," and "permitted" mean "directed by Architect/Engineer," "requested by Architect/Engineer," and similar phrases. However, no such implied meaning will be interpreted to extend the Architect's/Engineer's responsibility into the Contractor's area of construction supervision.
- E. Approve: Where used in conjunction with Architect's/Engineer's response to submittals, requests, applications, inquiries, reports and claims by Contractor, the meaning of term "approved" will be held to limitations of Architect's/Engineer's responsibilities and duties as specified in General and Supplementary Conditions. In no case will "approval" by Architect/Engineer be interpreted as a release of Contractor from responsibilities to fulfill requirements of contract documents.
- F. Project Site: The term "project site" is defined as the space available to Contractor for performance of the work. The extent of project site is shown on the drawings, and may or may not be identical with the description of land upon which the project is to be built.
- G. Furnish: Except as otherwise defined in greater detail, term "furnish" is used to mean supply and deliver to project site, ready for unloading, unpacking, assembly, installation, etc., as applicable in each instance.
- H. Install: Except as otherwise defined in greater detail, term "install" is used to describe operations at project site including unloading, unpacking, assembly, erection, placing, anchoring, applying, working to dimension, finishing, curing, protecting, cleaning and similar operations, as applicable in each instance.
- I. Provide: Except as otherwise defined in greater detail, term "provide" means furnish and install, complete and ready for intended use, as applicable in each instance.
- J. Installer: The term "installer" is defined as the entity (person or firm) engaged by Contractor, or its subcontractor or subcontractor for performance of a particular unit of work at the project site, including installation, erection, application and similar required operations. It is a general requirement that such entities (installers) be expert in operations they are engaged to perform.
- K. Testing Laboratory: The term "testing laboratory" is defined as an independent entity engaged to perform specific inspections or tests of the work, either at project site or elsewhere; and to report and (if required) interpret results of those inspections or tests.
- L. Products: The term "products" includes materials, systems and equipment.
- M. Approved Equal, Or Equal: means as approved and accepted by the Architect.
- N. Shall: The term "shall" is mandatory.
- O. As Required, As Necessary, etc.: Words of similar import mean as required by the Contract Documents or essential to the completion of the Work.
- P. Concealed: The term "concealed" means as embedded in masonry or other construction, installed within furred spaces, within double partitions or above suspended ceilings, in trenches, in crawl spaces, or in enclosures.

- Q. Exposed: The term "exposed" means not installed underground or "concealed" as defined above, including work and surfaces open in whole or in part to the exterior or weather.
- R. Work: The term "work" shall include both labor and materials.
- S. The Contract Documents:
The Contract Documents consist of the Contract, any addenda thereto, the completed Bid Form, the completed Bond and Insurance forms, the Notice Inviting Bids, the Instructions to Bidders, the General Conditions, the Supplementary General Conditions, the Labor Compliance Program, if any, the Technical Specifications, the Drawings and the Bidder's Questionnaire. All modification(s) amending or extending the work shall be as binding as if originally included in the Contract Documents. A Modification is a written amendment to the Contract signed by both parties, a Change Order, a Construction Change Directive, or a written order for a minor change in the Work issued by the Architect. The Contract Documents are complementary, and each obligation of the Contractor, Subcontractors, material or equipment suppliers in any one shall be binding as if specified in all.
- T. The Contract:
The Contract Documents form the Contract for Construction. The Contract represents the entire and integrated agreement between the parties hereto and supersedes prior negotiations, representations, or agreements, either written or oral. The Contract may be amended or modified only by a written Modification. The Contract Documents shall not be construed to create a contractual relationship of any kind between the Architect and Contractor, between the Owner and any Subcontractor or Sub-subcontractor, or between any persons or entities other than the Owner and the Contractor. The Architect shall, however, be entitled to performance and enforcement of obligations under the Contract intended to facilitate performance of the Architect's duties.
- U. The Work:
The Work shall include the initial obligation of any Contractor or Subcontractor, who performs any portion of the Work, to visit the Site of the proposed Work, a continuing obligation after the commencement of the Work to fully acquaint and familiarize itself with the conditions as they exist and the character of the operations to be carried on under the Contract Documents, and make such investigation as it may see fit so that it shall fully understand the facilities, physical conditions, and restrictions attending the Work under the Contract Documents. Each such Contractor or Subcontractor shall also thoroughly examine and become familiar with the Drawings, Specifications, and associated bid documents. The "Site" refers to the grounds of the Project as defined in the Contract Documents and such adjacent lands as may be directly affected by the performance of the Work.
- V. The Project:
The Project is the total construction of the Work performed in accordance with the Contract Documents in whole or in part and which may include construction by the Owner or by separate Contractors.
- W. The Drawings:
The Drawings are graphic and pictorial portions of the Contract Documents prepared for the Project and approved changes thereto, wherever located and whenever issued, showing the design, location, and scope of the Work, generally including plans, elevations, sections, details, schedules, and diagrams as drawn or approved by the Architect.

X. The Specifications:

The Specifications are that portion of the Contract Documents consisting of the written requirements for material, equipment, construction systems, instructions, quality assurance standards, workmanship, and performance of related services.

Y. The Project Manual:

The Project Manual is the volume usually assembled for the Work which may include, without limitation, the bidding requirements, sample forms, Conditions of the Contract, and Specifications.

1.04 FORMAT AND SPECIFICATION EXPLANATIONS

A. Format Explanation: The format of principal portions of these specifications can be described as in the following paragraphs. Although some portions of these specifications may not be in complete compliance with this format, no particular significance will be attached to such compliance or non-compliance.

1. Sections and Divisions: For convenience, the basic unit of text is a "section." Each section is identified by a descriptive title (name) and the number. Individual sections are grouped together with other sections of similar or related work groupings known as "divisions." Divisions are recognized as the present industry consensus on uniform specification organization and sequence. The section title is not intended to limit meaning or content of a section, nor to be fully descriptive of the requirements specified therein, nor to be an integral part of the text.
 - a. Each section of specifications has been subdivided into 3 "parts" for uniformity and convenience (Part 1-General, Part 2-Products, and Part 3 - Execution); some sections may not require the use of all three parts. These parts do not limit the meaning of and are not an integral part of text which specifies requirements.

B. Subordination of Text: Portions of specification text are subordinated to other portions in the following manner (lowest level to highest):

1. Indented (from left margin) paragraphs and lines of text are subordinate to preceding text which is not indented, or which is indented by a lesser amount.
2. Paragraphs and lines of text are subordinate to sub-article titles, which are printed in upper/lower-case lettering.
3. Sub-articles are the subordinate to article titles, which are printed in uppercase lettering.
4. Subordination (if any) of certain sections (or portions of sections) to other sections is described within those sections.
5. Underscoring is used strictly to assist the reader of specification text in scanning text for key words (for quick recall). No emphasis on or relative importance of text is intended where underscoring is used.
6. Imperative language is used generally in specifications. Except as otherwise indicated, requirements expressed imperatively are to be performed by Contractor. For clarity of reading at certain locations, contrasting subjective language is used to describe responsibilities which must be fulfilled indirectly by Contractor, or when so noted, by others.
7. Section numbering is used to facilitate cross references in the contract documents. Sections are placed in Project Manual in numeric sequence; however, numbering sequence is not complete, and listing of sections at beginning of Project Manual must be consulted to determine numbers and names of specification sections in contract documents.

8. Page Numbering: Pages are numbered independently for each section and are recorded in the listing of sections (Index or Table of Contents) in Project Manual. The section number is shown together with the page number at the bottom of each page to facilitate the location of text in the Project Manual.
 9. Project Identification: Project name (either complete or abbreviated) is recorded at top of each page of specifications to minimize possible misuse of specifications, or confusion with other project specifications.
- C. Specification Content: Because of methods by which the project specification has been produced, certain general characteristics of content and conventions in use of language are explained as follows:
1. Specifying Methods: The techniques or methods of specifying to record requirements varies throughout text, and may include "prescriptive," "open generic-descriptive," "compliance with standards," "performance," "proprietary," or a combination of these. The method used for specifying one unit of work has no bearing on requirements for another unit of work.
 2. Overlapping and Conflicting Requirements: Where compliance with 2 or more industry standards or sets of requirements is specified, and overlapping of those different standards or requirements establishes different or conflicting minimums or levels of quality, the most stringent requirement is intended and will be enforced, unless specifically detailed language written into the contract documents clearly indicates that a less stringent requirement is to be fulfilled. Refer apparently-equal-but-different requirements, and uncertainties as to which level of quality is more stringent, to Architect/Engineer for a decision before proceeding.
 3. Contractor's Options: Except for overlapping or conflicting requirements, where more than one set of requirements are specified, for a particular unit of work, option is intended to be Contractor's regardless of whether or not it is specifically indicated as such.
- D. Minimum Quality/Quantity: In every instance, quality level or quantity shown or specified is intended to be the minimum for the work to be performed or provided. Except as otherwise specifically indicated, actual work may either comply exactly with that minimum (within specified tolerances), or may exceed that minimum within reasonable limits. In complying with these requirements, indicated numeric values are either minimums or maximums as noted or as appropriate for context of the requirements. Refer instances of uncertainty to Architect/Engineer for decision before proceeding.
- E. Specialists, Assignments: In certain instances, specification text requires (or implies) that specific work is to be assigned to specialists or expert entities, who must be engaged for the performance of that work. Such assignments shall be recognized as special requirements over which the Contractor has no choice or option. These requirements should not be interpreted so as to conflict with the enforcement of building codes and similar regulations governing the work; they are also not intended to interfere with local union jurisdiction settlements and similar conventions. Such assignments are intended to establish which party or entity involved in a specific unit of work is recognized as "expert" for indicated construction processes or operations. Nevertheless, the final responsibility for fulfillment of entire set of contract requirements remains with the Contractor.
- F. Trades: Except as otherwise indicated, the use of titles such as "carpentry" in specification text, implies neither that the work must be performed by an accredited or unionized tradesperson of corresponding generic name (such as "carpenter"), nor that specified requirements apply exclusively to work by tradespersons of that corresponding generic name.

- G. Abbreviations: The language of specifications and other contract documents is of the abbreviated type in certain instances, and implies words and meanings which will be appropriately interpreted. Actual word abbreviations of a self-explanatory nature have been included in the texts. Specific abbreviations have been established, principally for lengthy technical terminology and primarily in conjunction with coordination of specification requirements with notations on drawings and in schedules. These are frequently defined in section at first instance of use. Trade association names and titles of general standards are frequently abbreviated.
1. Singular words will be interpreted as plural and plural words will be interpreted as singular where applicable and where full context of the contract documents so indicates.

1.05 DRAWING SYMBOLS

- A. General: Except as otherwise indicated, graphic symbols used on drawings are those symbols recognized in the construction industry for purposes indicated. Where not otherwise noted, symbols are defined by "Architectural Graphic Standards," published by John Wiley & Sons, Inc., seventh edition.
- B. Mechanical/Electrical Drawings: Graphic symbols used on mechanical and electrical drawings are generally aligned with symbols recommended by ASHRAE. Where appropriate, these symbols are supplemented by more specific symbols as recommended by other recognized technical associations including ASME, ASPE, IEEE and similar organizations. Refer instances of uncertainty to the Architect/Engineer for clarification before proceeding.

1.06 INDUSTRY STANDARDS

- A. General Applicability of Standards: Except to the extent that more explicit or more stringent requirements are written directly into the contract documents, applicable standards of the construction industry have the same force and effect (and are made a part of contract documents by reference) as if copied directly into the contract documents, or as if published copies were bound herewith. Refer to other contract documents for resolution of overlapping and conflicting requirements which result from the application of several different industry standards to the same unit of work. Refer to individual unit of work sections for indications of which specialized codes and standard the Contractor must keep at the project site, available for reference.
1. Referenced standards (referenced directly in contract documents or by governing regulations) have precedence over non-referenced standards which are recognized in industry for applicability to work. See also Chapter 35 of the CBC.
 2. Non-referenced standards are hereby defined to have no particular applicability to the work, except as general requirements of whether the work complies with standards recognized in the construction industry.
- B. Publication Dates: Except as otherwise indicated, where compliance with an industry standard is required, comply with standard in effect as of date of contract documents.
1. Updated Standards: At the request of the Architect/Engineer, Contractor or governing authority, submit a change order proposal where an applicable industry code or standard has been revised and reissued after the date of the contract documents and before the performance of the work affected. The Architect/Engineer will decide whether to issue the change order to proceed with the updated standard.

- C. Copies of Standards: The contract documents require that each entity performing work be experienced in that part of the work being performed. Each entity is also required to be familiar with recognized industry standards applicable to that part of the work. Copies of applicable standards are not bound with the contract documents.
1. Where copies of standards are needed for proper performance of the work, the Contractor is required to obtain such copies directly from the publication source.
 2. Although certain copies of standards needed for enforcement of the requirements may be required submittals, the Architect/Engineer reserves the right to require the Contractor to submit additional copies of these standards as necessary for enforcement of the requirements.
- D. Abbreviations and Names: The following acronyms or abbreviations as referenced in contract documents are defined to mean the associated names. Both names and addresses are subject to change, and are believed to be, but are not assured to be, accurate and up-to-date as of date of contract documents:

| | |
|--------|---|
| AA | Aluminum Association 1525 Wilson Boulevard, Suite 600, Arlington, VA 22209 www.aluminum.org |
| AAMA | American Architectural Manufacturers Association 1827 Walden Office Square, Suite 550, Schaumburg, IL 60173-4268 www.aamanet.org ; 847.303.5664 |
| AAN | American Association of Nurserymen 1200 G St. Suite 800; Washington, DC 20005 www.anla.org ; 202 789 2900 |
| AASHTO | American Association of State Highway & Transportation Officials 444 N. Capitol St.; Washington, DC 20001 www.transportation.org ; 202 624 5800 |
| AATCC | American Association of Textile Chemists and Colorists P.O. Box 12215; Research Triangle Park, NC 27709-2215 www.aatcc.org ; 919 549 8141 |
| ACA | American Coatings Association 1500 Rhode Island Ave., NW; Washington, DC 20005 www.paint.org ; 202-462-6272 |
| ACI | American Concrete Institute 38800 Country Club Dr., Farmington Hills, MI 48331-3439 www.concrete.org ; 313 532-2600 |
| ACIL | American Council of Independent Laboratories 1725 K Street, NW; Washington, DC 20006 www.acil.org ; 202 887-5872 |
| ACPA | American Concrete Pipe Association |

- 8445 Freeport Parkway, Suite 350, Irving TX 75063-2595
www.concrete-pipe.org 972 506 7216
- AF&PA American Forest & Paper Association
1111 19th St. NW, Suite 800, Washington, CD 20036
www.afandpa.org
- AGA American Gas Association
400 N. Capitol St. NW, Washington DC 20001
www.aga.org 202 824 7000
- AHAM Association of Home Appliance Manufacturers
1111 19th St. NW, Suite 402, Washington, DC 20036
www.aham.org 202 872 5955
- AI Asphalt Institute
2696 Research Park Drive, Lexington, KY 40511-8480;
www.asphaltinstitute.org 859 288 4960
- AIA American Institute of Architects
1735 New York Ave. NW; Washington, DC 20006-5292
www.aia.org 800 242 3837
- A.I.A. American Insurance Association
2101 L Street NW, Suite 400, Washington DC 20037
www.aiadc.org 202 828 7100
- AISC American Institute of Steel Construction
One East Wacker Drive, Suite 700, Chicago, IL, 60601-18021
www.aisc.org 312 670 2400
- AISI American Iron and Steel Institute
25 Massachusetts Ave NW Suite 800, Washington, DC 20001
www.steel.org 202 452 7100
- AITC American Institute of Timber Construction
www.aitc-glulam.org 503 639 0651
- ALSC American Lumber Standard Committee, Inc.
P.O. Box 210; Germantown, MD 20875-0210;
www.alsc.org 301 972 1700
- ANSI American National Standards Institute
25 West 43rd St. 4th Floor, New York, NY 10036
www.ansi.org 212 642 4900
- APA American Plywood Association
7011 South 19th, Tacoma, WA 98466;
www.apawood.org 253 620 7400

| | |
|----------|---|
| ARI | Air Conditioning, Heating and Refrigeration Institute 2111 Wilson Blvd, Suite 500.; Arlington, VA 22201; www.ahrinet.org 703 524 8800 |
| ASC | Adhesive and Sealant Council 7101 Wisconsin Ave, Ste 990, Bethesda, MD 20814; 301-986-9700 www.ascouncil.org |
| ASCE/SEI | American Society of Civil Engineers Structural Engineering Institute 1801 Alexander Bell Drive, Reston, VA 20191-4400 www.asce.org; 800 548 2723 |
| ASHRAE | American Society of Heating, Refrigerating & Air Conditioning Engineers 1719 Tullie Circle, NE; Atlanta, GA 30329; www.ashrae.org ; 404 636 8400 |
| ASME | American Society of Mechanical Engineers Three Park Ave, New York, NY 10016-5990 www.asme.org; 800-843-2763 |
| ASPE | American Society of Plumbing Engineers 2980 S. River Road; Des Plaines, IL 60018 www.aspe.org; 847-296-0002 |
| ASSE | American Society of Sanitary Engineers-CA Chapter 1111 W. James Wood Blvd.; Los Angeles, CA 90015 www.asse-plumbing.org; 213-688-9090 |
| ASTM | American Society for Testing and Materials 100 Barr Harbor Dr / PO Box C700, West Conshohocken, PA 19428 www.astm.org; 215 299-5400 |
| AWI | Architectural Woodwork Institute 46179 Westlake Drive;, Ste 120; Potomac Falls, VA 20165 571-323-3636 |
| AWS | American Welding Society 8669 Doral Boulevard, Suite 130, Doral FL 33166 www.aws.org; 800 443 9353 |
| AWPA | American Wood Protection Association P.O. Box 361784; Birmingham AL 35236-1784 www.awpa.com |
| AWWA | American Water Works Association 6666 W. Quincy Ave., Denver, CO 80235 303-794-7711 |
| BHMA | Builders' Hardware Manufacturers Association |

355 Lexington Ave 17th Floor, New York, NY 10017;
www.buildershardware.com; 212-297-2122

- BIFMA Business and Institutional Furniture Manufacturer's Association
678 Front Ave NW, Ste. 150; Grand Rapids, MI 49504-5368; 616-285-3963
- CBMA Certified Ballast Manufacturers
2122 Keith Bldg.; Cleveland, OH 44115; 216 241-0711
- CDA Copper Development Association
260 Madison Ave; New York, NY 10016; 212-251-7200
- CISPI Cast Iron Soil Pipe Institute
1064 Delaware Ave. SW, Atlanta, GA 30316
www.cispi.org; 404 622 0073
- CPA Composite Panel Association
19465 Deerfield Ave. Suite 306, Leesburg, VA 20176
www.compositepanel.org
- CPSC Consumer Product Safety Commission
4330 East West Highway; Bethesda, MD 20814-4408; 301-504-7923
- CRI Carpet and Rug Institute
Box 2048/730 College Dr.; Dalton, GA 30720; 706-278-3176
- CRSI Concrete Reinforcing Steel Institute
933 Plum Grove Rd.; Schaumburg, IL 60173; 847-517-1200
- CSA Canadian Standards Association
5060 Spectrum Way, Mississauga, Ontario, Canada L4W 5N6
- CSI Construction Specifications Institute
110 South Union St., Ste. 100; Alexandria, VA 22314; 800-689-2900
www.csinet.org
- CTI Ceramic Tile Institute
310-574-7800
- DHI Door and Hardware Institute
14150 Newbrook Drive, Ste. 200; Chantilly, VA 20151-2232
www.dhi.org; 703-222-2010
- DLPA Decorative Laminate Products Association (Formerly National Association of
Plastic Fabricators) Hulman Building; 20th Floor;
120 West Second Street;
Dayton, OH 45402; 513/228-1041

| | |
|------|---|
| DOC | US Dept. of Commerce, National Institute of Standards and Technology 1401 Constitution Avenue NW, Washington DC 20230 |
| DOJ | US Department of Justice 950 Pennsylvania Ave. NW Civil Rights Division, Disability Rights Section-NYA Washington DC 20530 |
| DOTn | Department of Transportation 1200 New Jersey Ave, SE; Washington, DC 20402-9325 202 426 4000 |
| EIA | Electronic Industries Association 2001 Eye St., NW: Washington, DC 20006; 202 457-4900 |
| EPA | Environmental Protection Agency 2001 Eye St., NW; Washington DC 20006; www.epa.gov; 202 457 4900 |
| FEMA | Federal Emergency Management Agency, Federal Center Plaza 500 C St. S.W., Washington DC 20472 www.fema.gov |
| FGMA | Flat Glass Marketing Association White Lakes Professional Bldg; 3310 Harrison; Topeka, KS 66611; 913 266-7013 |
| FM | Factory Mutual Global Research, Standards Laboratory Dept.. 1301 Attwood Ave. POB 7500, Johnson, RI 02919; www.fmglobal.com |
| GA | Gypsum Association 810 First St. N.E. #510, Washington, DC 20002-4268 www.gypsum.org; 301 277 6886 |
| HMMA | Hollow Metal Manufacturers Association See NAAMM below. |
| HPVA | Hardwood Plywood Veneer Association 1825 Michael Farraday Dr., Reston, VA 20190 www.hpva.org |
| HUD | US Dept. of Housing and Urban Development 451 7 th St. SW, Washington, DC 20410 |
| IBC | International Building Code 500 New Jersey Ave. NW 6 th Floor, Washington, DC 20001 www.iccsafe.org |

| | |
|-------|--|
| ICC | International Code Council 500 New Jersey Ave NW, 6 th Floor, Washington DC 20001 www.iccsafe.org |
| IEEE | Institute of Electrical and Electronic Engineers, Inc. 3 Park Ave, 17 th Floor; New York, NY 10016 212-419-7900 |
| IES | Illuminating Engineering Society 120 Wall St., Floor 17, New York, NY 10005-4001 212-248-5000 |
| IRI | Industrial Risk Insurers 85 Woodland St.; Hartford, CT 06102; 203/525-2601 |
| ISO | International Organization for Standardization ISO Central Secretariat 1 ch. De la Voie-Creuse, Case Postale 56 CH-1211 Geneva 20, Switzerland www.iso.org |
| MCAA | Mechanical Contractors Association of America 1385 Piccard Dr.; Rockville, MD 20850; 301-869-5800 |
| MSS | Manufacturers Standardization Society of the Valve and Fittings Industry 127 Park St. NE; Vienna VA 22180-4602; 703-281-6613 |
| NAAMM | National Association of Architectural Metal Mfrs. 800 Roosevelt Rd. Bldg C, Ste 312; Glen Ellyn, IL 60137 www.naamm.org; 630-942-6591 |
| NBHA | National Builders Hardware Association (No Part of HDI) 711 Old Springhouse Rd.; McLean, VA 22101; 703 556-3990 |
| NBS | National Bureau of Standards (U.S. Dept. of Commerce) Gaithersburg, MD 20234; 301 921-1000 |
| NCMA | National Concrete Masonry Association 13750 Sunrise Valley, Herndon, VA 22071-4662 |
| NECA | National Electrical Contractors Association 3 Bethesda Metro Center, Ste. 1100; Bethesda, MD 20814; 301 657 3110 |
| NEII | National Elevator Industry, Inc. 1677 Country Route 64/PO Box 838; Salem, NY 12865-0838 518-854-3100 |
| NEMA | National Electrical Manufacturers Association |

1300 North 17th Street, Ste. 1752, Rosslyn, VA 22209; 703-841-3200

| | |
|--------|--|
| NFPA | National Fire Protection Association 1 Batterymarch Park, Quincy, MA 02169-7471 www.nfpa.org; 617 770 3000 |
| NHLA | National Hardwood Lumber Association P.O. Box 34518; Memphis, TN 38104; 901 377-1818 www.nhla.com |
| NIST | National Institute of Standards and Technology (US Dept. of Commerce) 1401 Constitution Avenue NW, Washington DC 20230 www.nist.gov |
| NRCA | National Roofing Contractors Association 10255 W. Higgins Rd., Ste. 600, Rosemont, IL 60018-5607 www.nrca.net; 847-299-9070 |
| NSF | National Sanitation Foundation P.O. Box 130140/789 N. Dixboro Road, Ann Arbor, MI 48113-0140 www.nsf.org 800-673-6275 |
| OSHA | Occupational Safety & Health Administration (U.S. Dept. of Labor) 200 Constitution Ave; Washington, DC 20210 www.osha.gov 800-321-6742 |
| PCI | Precast Prestressed Concrete Institute 209 W. Jackson Blvd., Suite 500, Chicago, IL 60606-6938 www.pci.org |
| PDI | Plumbing and Drainage Institute 800 Turnpike Street, Ste. 300; North Andover, MA 01845 www.pdionline.org 978-557-0720 |
| PTI | Post-Tensioning Institute 38800 Coutry Club Dr., Farmington Hills, MI 48331 www.post-tensioning.org |
| RFCI | Resilient Floor Covering Institute 115 Broad Street, Ste. 201; La Grange, GA 30240 www.rfci.com |
| RIS | Redwood Inspection Service (Grading Rules) 818 Grayson Rd., Ste. 201; Pleasant Hill, CA 94523 www.redwoodinspection.com 925-935-1499 |
| SDI | Steel Deck Institute POB 25, Fox River Grove, IL 60021 ww.sdi.org |
| S.D.I. | Steel Door Institute |

| | |
|--------|---|
| | 30200 Detroit Rd.; Westlake, OH 44145 www.steeldoor.org 440-899-0010 |
| SFM | State of California, Dept. of Forestry and Fire Protection Office of the State Fire Marshal, POB 944246, Sacramento, CA 94246 osfm.fire.ca.gov |
| SGCC | Safety Glazing Certification Council 100 W. Main St. / PO Box 730; Sackets Harbor, NY 13685; 315-646-2234 |
| SJI | Steel Joist Institute 1173B London Links Dr., Forest, VA 24551 steeljoist.org |
| SMACNA | Sheet Metal & Air Conditioning Contractors' National Association 4201 Lafayette Center Drive, Chantilly, VA 20151-1219 www.smacna.org 703-803-2980 |
| SPRI | Single-ply Roofing Institute 411 Waverly Oaks Rd., Suite 331B, Waltham, MA 02452 www.spri.org |
| SSPC | Steel Structure Painting Council (The Society for Protective Coatings) 40 24 th Street, 6 th Floor, Pittsburgh, PA, 15222-4656 www.sspc.org |
| TCNA | Tile Council of North America 100 Clemson Research Blvd., Anderson, SC 29625, www.tcnatile.com 864-646-8453 |
| TIA | Telecommunications Industry Association 2500 Wilson Blvd., Ste 300; Arlington VA 22201 www.tiaonline.org 703-907-7700 |
| TMS | The Masonry Society 3970 Broadway, Unit 201-D, Boulder, CO 80304-1135 www.masonrysociety.org |
| TPI | Truss Plate Institute 218 N. Lee St., Suite 312, Alexandria, VA 22314 www.tpinst.org |
| UL | Underwriters Laboratories 333 Pfingsten Rd.; Northbrook, IL 60062-2096 www.ul.com 847 272 8800 |
| ULC | Underwriters Laboratories of Canada 7 Underwriters Rd., Toronto, Ontario, Canada M1R3B4 www.ul.com/Canada/eng/pages/aboutus/ |

| | |
|----------|--|
| USC | United States Code, c/o Superintendent of Documents US Government Printing Office, Washington, DC 20402-9325 |
| WCLIB | West Coast Lumber Inspection Bureau (Grading Rules) P.O. Box 23145; Portland, OR 97281 www.wclib.org 503 639 0651 |
| WDMA | Window and Door Manufacturers Association 1400 E. Touhy, #470, Des Plaines, IL 60018 www.wdma.com |
| WI (WIC) | Woodwork Institute PO Box 980247; West Sacramento, CA 95798 www.wicnet.org 916-372-9943 |
| WRI | Wire Reinforcement Institute 942 Main Street; Hartford, CT 06103 www.wirereinforcementinstitute.org |
| WSC | Water Systems Council 1101 30 th Street Northwest; Washington, DC 20007-3708 www.watersystemscouncil.org 888 395 1033 |
| WWPA | Western Wood Products Association (Grading Rules) 522 SW Fifth Ave., Ste. 500; Portland, OR 97204-2122 www.wwpa.org 503 224-3930 |
| W.W.P.A | Woven Wire Products Association www.wovenwire.org |

1.07 GOVERNING REGULATIONS/AUTHORITIES

- A. General: The procedure followed by Architect/Engineer has been to contact governing authorities where necessary to obtain information needed for the purpose of preparing contract documents; recognizing that such information may or may not be of significance in relation to Contractor's responsibilities for performing the work. Contact governing authorities directly for necessary information and decisions having a bearing on performance of the work.

- B. Trade Union Jurisdiction: It is a procedural requirement that the Contractor maintain and require prime subcontractors to maintain, complete current information on jurisdictional matters, regulations actions, and pending actions, as applicable to the work.
 - 1. Discuss new developments at appropriate project meetings at the earliest feasible dates.
 - 2. Record information of relevance along with the action agreed upon.
 - 3. The manner in which contract documents have been organized and subdivided is not intended to be an indication of jurisdictional or trade union agreements.
 - 4. Assign and subcontract the work, and employ tradesmen and laborers, in a manner which will not unduly risk jurisdictional disputes of a kind which could result in conflicts, delays, claims and losses in the performance of the work.

1.08 SUBMITTALS

- A. Permits, Licenses and Certificates: For the Owner's records, submit copies of permits, licenses, certifications, inspection reports, releases, jurisdictional settlements, notices, receipts for fee payments, judgements, and similar documents, correspondence and records established in conjunction with compliance with standards and regulations bearing upon performance of the work.

PART 2 PRODUCTS

Not Used

PART 3 EXECUTION

Not Used

END OF SECTION

SECTION 01 4523

TESTING AND INSPECTION SERVICES

PART 1 GENERAL

1.01 DESCRIPTION

- A. Work Included:
1. Selection and payment of Testing and Inspection Agency
 2. Testing and Inspection Agency submittals.
 3. Testing and Inspection Agency responsibilities.
 4. Testing and Inspection Agency reports.
 5. Limits on Testing and Inspection authority.
 6. Contractor's Responsibilities.
 7. Architect's Responsibilities.

1.02 RELATED SECTIONS

- A. Related Sections:
1. Drawings and Contract Documents, including General and Supplemental General Conditions.
 2. Section 01 3300 - Submittals: Manufacturer's certificates.
 3. Section 01 4000 - Quality Control.
 4. Section 09 0512 - Concrete Floor Moisture Content & pH Testing
 5. Section 01 7500 - Starting of Systems.
 6. Technical Specifications - Pertinent Sections requiring tests and inspections.

1.03 REFERENCES

- A. ASTM C802 - Practice for Conducting an Interlaboratory Test Program to Determine the Precision of Test Methods for Construction.
- B. ASTM C1021 - Practice for Laboratories Engaged in the Testing of Building Sealants.
- C. ASTM C1077 - Practice for Laboratories Testing Concrete and Concrete Aggregates for Use in Construction and Criteria for Laboratory Evaluation.
- D. ASTM C1093 - Practice for Accreditation of Testing Agencies for Unit Masonry.
- E. ASTM D290 - Recommended Practice for Bituminous Mixing Plant Inspection.
- F. ASTM D3740 - Practice for Evaluation of Agencies Engaged in Testing and/or Inspection of Soil and Rock as Used in Engineering Design and Construction.
- G. ASTM D4561 - Practice for Quality Control Systems for an Inspection and Testing Agency for Bituminous Paving Materials.

- H. ASTM E329 - Practice for Use in the Evaluation of Inspection and Testing Agencies as Used in Construction.
- I. ASTM E543 - Practice for Determining the Qualification of Nondestructive Testing Agencies.
- J. ASTM E548 - Practice for Preparation of Criteria for Use in the Evaluation of Testing Laboratories and Inspection Bodies.
- K. ASTM E699 - Practice for Criteria for Evaluation of Agencies Involved in Testing, Quality Assurance, and Evaluating Building Components in Accordance with Test Methods Promulgated by ASTM Committee E6.

1.04 SELECTION AND PAYMENT

- A. An independent testing laboratory approved by DSA shall perform inspections, tests, and other services as specified by various specification sections.
 - 1. Owner will employ and pay for testing laboratory to provide initial testing indicated under specific specification sections and specifically noted to be paid by the Owner.
 - 2. Contractor shall be back-charged for testing costs when:
 - a. Additional tests and inspections by Owner's testing agency where initial tests and inspections reveal failure to meet Contract requirements.
 - b. Excessive inspection time by Owner's testing agency is required by Contractor's failure to provide sufficient workman or to properly pursue the progress of work.
 - c. Test(s) deemed necessary by the Owner/Architect to evaluate any substitution proposed by the Contractor.
 - d. Testing and inspection for the Contractor's convenience.
 - e. Testing and inspection overtime necessitated by the Contractor's schedule.
- B. Employment of inspection firm in no way relieves Contractor of obligation to perform Work in accordance with requirements of Contract Documents.
- C. Employment of any testing laboratory by Contractor shall be subject to Owner approval; laboratory shall be under direct supervision of a registered Engineer and shall conform to ASTM 329. Laboratory of concrete producer shall not be acceptable for concrete mix designs.
- D. Owner reserves the right to test any material or work of Project at any time, whether or not tests are indicated in Contract Documents.

1.05 QUALITY ASSURANCE

- A. Conform to requirements of the referenced standards.
- B. Laboratory: Authorized to operate in State in which Project is located.
- C. Laboratory Staff: Maintain a full time registered Engineer on staff to review services.
- D. Testing Equipment: Calibrated at reasonable intervals with devices of an accuracy traceable to either National Bureau of Standards or accepted values of natural physical constants.

1.06 CONTRACTOR SUBMITTALS

- A. Prior to start of Work, submit testing laboratory OR inspection firm's name, address, and telephone number, and names of full time registered Engineer and responsible officer.
- B. Each Contractor responsible for the construction of a main wind- or seismic-force resisting system, designated seismic or a wind- or seismic-resisting component list in the statement of special inspections shall submit a written statement of responsibility prior to commencement of work on the system or component. A copy of this written statement shall be maintained at the project site and made available upon request. The Contractor's statement of responsibility shall contain the following:
 - 1. Acknowledgment of awareness of the special requirements contained in the statement of special inspections;
 - 2. Acknowledgement that control will be exercised to obtain conformance with the construction documents approved by the building official;
 - 3. Procedures for exercising control within the Contractor's organization, the method and frequency of reporting and the distribution of the reports; and
 - 4. Identification and qualifications of the person(s) exercising such control and their position(s) in the organization.
- C. Submit copy of report of laboratory facilities inspection made by Materials Reference Laboratory of National Bureau of Standards during most recent inspection, with memorandum of remedies of any deficiencies reported by the inspection.

1.07 AGENCY RESPONSIBILITIES

- A. Test samples of mixes submitted by Contractor.
- B. Provide qualified personnel at site. Cooperate with Architect/Engineer and Contractor in performance of services.
- C. Perform specified sampling and testing of Products in accordance with specified standards.
- D. Ascertain compliance of materials and mixes with requirements of Contract Documents.
- E. Promptly notify Architect/Engineer and Contractor of observed irregularities or non-conformance of Work or Products.
- F. Perform additional tests required by Architect/Engineer.
- G. Attend preconstruction meetings and progress meetings.

1.08 AGENCY AND INSPECTION REPORTS

- A. After each test, observation or inspection, promptly submit copies of report to Architect, Engineer, DSA, Owner's Inspector, Owner, Contractor and as otherwise directed.
- B. Include:
 - 1. Date issued.
 - 2. Project title and number.
 - 3. Name of inspector.
 - 4. Date and time of sampling or inspection.
 - 5. Identification of product and specifications section.
 - 6. Location in the Project.

7. Type of inspection or test.
8. Date of test.
9. Results of tests.
10. Conformance with Contract Documents.

C. When requested by Architect/Engineer, provide interpretation of test or inspection results.

1.09 LIMITS ON TESTING and INSPECTION AUTHORITY

- A. Agency or laboratory may not release, revoke, alter, or enlarge on requirements of Contract Documents.
- B. Agency or laboratory may not approve or accept any portion of the Work.
- C. Agency or laboratory may not assume any duties of Contractor.
- D. Agency or laboratory has no authority to stop the Work.

1.10 CONTRACTOR RESPONSIBILITIES

- A. Provide information regarding activities requiring special inspection and tests to District's inspection and testing laboratory upon request.
- B. Provide agency or laboratory representative access to any chosen location and adequate samples of materials proposed to be used which require testing, along with proposed mix designs.
- C. Cooperate with laboratory personnel, and provide access to the Work.
- D. Provide incidental labor and facilities:
 1. To provide access to Work to be tested.
 2. To obtain and handle samples at the site or at source of Products to be tested.
 3. To facilitate tests.
 4. To provide storage and curing of test samples.
- E. Notify agency or laboratory and Architect/Engineer forty-eight (48) hours prior to expected time for operations requiring testing services. Become familiar with time constraints of tests required. Schedule work to allow time for performance of required tests.
- F. Employ services of an independent qualified testing laboratory and pay for additional samples and tests required by Contractor beyond specified requirements.

1.11 ARCHITECT RESPONSIBILITIES

- A. Architect is not responsible for notification of the Testing Agency or scheduling its work.
- B. Architect will not be responsible for the actions of the Testing Agency.

1.12 RE-TESTING

- A. When initial tests indicate non-compliance with the Contract Documents, subsequent re-testing shall be performed by the same testing laboratory and the costs thereof shall be paid by the Owner and deducted from the Contract Sums owed to the Contractor.

1.13 SCHEDULE OF INSPECTIONS

- A. Division of State Architect Form SSS-103 SCHEDULE OF TESTS AND INSPECTIONS is attached.
- B. Individual Specification Sections: Other tests or inspections required; standards for testing.

PART 2 PRODUCTS - NOT USED.

PART 3 EXECUTION - NOT USED.

END OF SECTION

DIVISION OF STATE ARCHITECT FORM SSS-103 SCHEDULE OF TESTS AND INSPECTIONS FOLLOWS
THIS SECTION



Issued 9/1/2017

DSA-103 List of Required Structural Tests & Special Inspections - 2016 CBC

INCREMMENT # DSA File No.: 7-H4
 Application No.: 01-117742
 Revised:
 Date Submitted: Revised:

| | | | |
|-------------|---|----------|------------------------------------|
| School Name | Liberty High School Stadium Improvement | District | Liberty Union High School District |
|-------------|---|----------|------------------------------------|

IMPORTANT: This form is only a summary list of structural tests and some of the special inspections required for the project. Generally, the structural tests and special inspections noted on this form are those that will be performed by the Geotechnical Engineer of Record, Laboratory of Record, or Special Inspector. The actual complete test and inspection program must be performed as detailed on the DSA approved documents. The appendix at the bottom of this form identifies work NOT subject to DSA requirements for special inspection or structural testing. The project inspector is responsible for providing inspection of all facets of construction, including but not limited to, special inspections not listed on this form such as structural wood framing, high-load wood diaphragms, cold-formed steel framing, anchorage of non-structural components, etc., per Title 24, Part 2, Chapter 17A.

NOTE: This form is also available for projects submitted for review under the 2007, 2010, and 2013 CBC.

INSTRUCTIONS: Click a plus sign (+) before any category or subcategory to reveal additional tests and special inspections. A shaded box indicates a test or special inspection that may be required, depending on the scope of the construction and other issues. A shaded box can be clicked indicating your selection of that test. **Note:** A minus (-) on a category or subcategory heading indicates that it can be collapsed. However, any selections you may have made will be cleared. Click on the "COMPILE" button to show only the tests and inspections finally selected. **For more information on use of this form, see DSA-103.INSTR.**

Note: References are to the 2016 edition of the California Building Code (CBC) unless otherwise noted.

| REQUIRED | TEST OR SPECIAL INSPECTION | TYPE 1 | PERFORMED BY 2 | | CODE REFERENCE AND NOTES |
|----------|--|---|----------------|---|---|
| | | | 1 | 2 | |
| - | SOILS | | | | |
| - | 1. GENERAL: | | | | |
| X | a. Verify that: • site has been prepared properly prior to placement of controlled fill and/or excavations for foundations, • foundation excavations are extended to proper depth and have reached proper material, and • materials below footings are adequate to achieve the design bearing capacity. | Periodic | GE* | | * By geotechnical engineer or his or her qualified representative. (See Appendix for exemptions.) |
| - | 2. COMPACTED FILLS: | | | | |
| X | a. Perform classification and testing of fill materials. | Test | LOR* | | * Under the supervision of the geotechnical engineer. |
| X | b. Verify use of proper materials, densities and inspect lift thicknesses, placement, and compaction during placement of fill. | Continuous | GE* | | * By geotechnical engineer or his or her qualified representative. |
| X | c. Test compaction of fill. | Test | LOR* | | * Under the supervision of the geotechnical engineer. |
| - | 4. CAST-IN-PLACE DEEP FOUNDATIONS (PIERS): | | | | Table 1705A.8 |
| X | a. Inspect drilling operations and maintain complete and accurate records for each pier. | Continuous | GE* | | * By geotechnical engineer or his or her qualified representative. (See Appendix for exemptions.) |
| X | c. Verify pier locations, diameters, plumbness, bell diameters (if applicable), lengths, and embedment into bedrock (if applicable). Record concrete or grout volumes. | Continuous | GE* | | * By geotechnical engineer or his or her qualified representative. (See Appendix for exemptions.) |
| X | e. Concrete piers. | Provide tests and inspections per CONCRETE section below. | | | |
| - | 5. RETAINING WALLS: | | | | |



DSA-103 Issued 9/1/2017

List of Required Structural Tests & Special Inspections - 2016 CBC

INCREMENT # DSA File No.:
 Application No.:
 Date Submitted: Revised:
 Revised:

| X | a. | Placement of soil reinforcement, drainage devices, and backfill. | Continuous | GE* | Placement, compaction and inspection of backfill per Section 1705A.6.1 for fills supporting foundations (see Section 2 above). * By geotechnical engineer or his or her qualified representative. |
|---|---|--|---|-----|---|
| X | c. | Concrete retaining walls. | Provide tests and inspections per CONCRETE section below. | | |
| - | CONCRETE | | | | |
| - | 7. CAST IN PLACE CONCRETE | | | | |
| Material Verification and Testing: | | | | | |
| X | a. | Verify use of required design mix. | Periodic | SI* | Table 1705A.3 Item 5, 1910A.1 (1909.2.3)*. * To be performed by qualified batch-plant inspector and concrete sampling technician |
| X | b. | Identify, sample, and test reinforcing steel. | Test | LOR | 1910A.2 (1909.2.4*); ACI 318-14 Section 26.6.1.2. DSA IR 17-10.16 |
| X | c. | During concrete placement, fabricate specimens for strength tests, perform slump and air content tests, and determine the temperature of the concrete. | Test | LOR | Table 1705A.3 item 6; ACI 318-14 Sections 26.5 & 26.12 |
| X | d. | Test concrete (f _c). | Test | LOR | 1905A.1.16 (1909.3.7*); ACI 318-14 Section 26.12. |
| Inspection: | | | | | |
| X | e. | Batch plant inspection <input checked="" type="radio"/> Continuous <input type="radio"/> Periodic | See Notes | SI | Default of 'Continuous' per 1705A.3.3; If approved by DSA, batch plant inspection may be reduced to 'Periodic' subject to requirements in Section 1705A.3.3.1 or eliminated per 1705A.3.3.2. (See Appendix for exemptions.) |
| - | 11. POST-INSTALLED ANCHORS: | | | | |
| X | a. | Inspect installation of post-installed anchors | See Notes | SI* | Table 1705A.3 Item 4a (Continuous) & 4b (Periodic) (see Appendix for exemptions). ACI 318-14 Sections 17.8 & 26.13 * May be performed by the project inspector when specifically approved by DSA. |
| X | b. | Test post-installed anchors. | Test | LOR | 1910A.5 (1909.2.7*). (See Appendix for exemptions.) |
| + | MASONRY | | | | |
| - | TMS 402-13/ACI 530-13/ASCE 5-13 Table 3.1.3 & TMS 602-13/ACI 530.1-13/ASCE 6-13 Table 5 | | | | |
| - | Table 1705A.2.1, AISC 303-10, AISC 360-10, AISC 341-10, AISC 358-10, AISI S100-07/IS2-10 | | | | |
| - | STEEL, ALUMINUM | | | | |
| - | 17. STRUCTURAL STEEL, COLD-FORMED STEEL, AND ALUMINUM USED FOR STRUCTURAL PURPOSES | | | | |
| Material Verification: | | | | | |
| X | a. | Verify identification of all materials and: • Mill certificates indicate material properties that comply with requirements, • Material sizes, types and grades comply with requirements. | Periodic | * | 2203A.1 (2203.1*), Table 1705A.2.1 Item 3a-3c; AISI S100-07/IS2-10 Section A2.1 & A2.2, AISI S200-12 Section A3, AISI S220-11 Section A4. * By special inspector or qualified technician when performed off-site. |
| X | b. | Test unidentified materials | Test | LOR | 2203A.1 (2203.1*) |
| X | c. | Examine seam welds of HSS shapes | Periodic | SI | DSA IR 17-3. |
| Inspection: | | | | | |
| X | e. | Verify and document steel fabrication per DSA approved construction documents. | Periodic | SI | Not applicable to cold-formed steel light-frame construction, except for trusses (1705A.2.4). 1705A.2.5, Table 1705A.2.1 Items 4 & 5; DSA IR 17-3, AWS D1.1 and AWS D1.8 for structural steel, AWS D1.2 for Aluminum, AWS D1.3 for cold-formed steel, AWS D1.4 for reinforcing steel. (See Appendix for exemptions.) |
| - | 19. WELDING: | | | | |
| Verification of Materials, Equipment, Welders, etc: | | | | | |
| X | a. | Verify weld filler material identification markings per AWS designation listed on the DSA approved documents and the WPS. | Periodic | SI | DSA IR 17-3. |

Issued 9/1/2017

DSA-103



List of Required Structural Tests & Special Inspections - 2016 CBC

INCREMNT # DSA File No.:
 Application No.:
 Date Submitted: Revised:
 Revised:

| | | Periodic | SI | DSA IR 17-3. |
|---|---|------------|-----|--|
| X | b. Verify weld filler material manufacturer's certificate of compliance. | Periodic | SI | DSA IR 17-3. |
| X | c. Verify WPS, welder qualifications and equipment. | Periodic | SI | DSA IR 17-3. |
| - | 19.1 SHOP WELDING: | | | |
| X | a. Inspect groove welds, multi-pass fillet welds, single pass fillet welds > 5/16", plug and slot welds | Continuous | SI | Table 1705A.2.1 Item 5a1-4. Per AISC 360-10 (and AISC 341-10 as applicable). DSA IR 17-3. |
| X | b. Inspect single-pass fillet welds ≤ 5/16", floor and roof deck welds | Periodic | SI | 1705A.2.2, Table 1705A.2.1 Item 5a.5 & 5a.6. Per AISC 360-10 (and AISC 341-10 as applicable). DSA IR 17-3. |
| X | c. Inspect welding of stairs and railing systems. | Periodic | SI | 1705A.2.1. Per AISC 360-10 (and AISC 341-10 as applicable), AWS D1.1 & D1.3. DSA IR 17-3. |
| - | 19.2 FIELD WELDING: | | | |
| X | b. Inspect single-pass fillet welds ≤ 5/16" | Periodic | SI | Table 1705A.2.1 Item 5a.5. Per AISC 360-10 (and AISC 341-10 as applicable). DSA IR 17-3. |
| - | 20. NONDESTRUCTIVE TESTING: | | | |
| X | a. Ultrasonic | Test | LOR | 1705A.2.1 & 1705A.2.2, AISC 308-10 TB-3, AISC 308-10 TB-2, AWS D1.1, D1.3, AWS/ASNT CP-180, SNT-TC-1A, DSA IR 17-3 |
| - | 23. ANCHOR BOLTS, ANCHOR RODS, & OTHER STEEL: | | | |
| X | a. Anchor Bolts and Anchor Rods | Test | LOR | IR 17-11 Sample and test anchor bolts and anchor rods not readily identifiable. |
| - | WOOD | | | |
| + | 24. PREFABRICATED WOOD STRUCTURAL ELEMENTS: | | | Section 1705A.5 |
| + | OTHER | | | |



DSA-103
Issued 9/1/2017

List of Required Structural Tests & Special Inspections - 2016 CBC

INCREMENT # _____ DSA File No.: _____
 Application No.: _____
 Date Submitted: _____ Revised: _____
 Revised: _____

List of required verified report(s):

- 1 Soils testing and Inspection: Geotechnical Verified Report - Form DSA-293
- 2 All Structural Testing: Laboratory Verified Report - Form DSA-291
- 3 Concrete Batch Plant Inspection: Laboratory Verified Report - Form DSA-291
- 4 Shop Welding Inspection: Laboratory Verified Report - Form DSA-291, or, for independently contracting SI, Special Inspection Verified Report - Form DSA-292
- 5 Field Welding Inspection: Laboratory Verified Report - Form DSA-291, or, for independently contracting SI, Special Inspection Verified Report - Form DSA-292

KEY to Columns

| 1 | Type - | 2 | Performed By - |
|------------|--|-----|--|
| Continuous | - Indicates that a continuous special inspection is required | GE | - Indicates that the special inspection is to be performed by a registered geotechnical engineer or his or her authorized representative |
| Periodic | - Indicates that a periodic special inspection is required | LOR | - Indicates that the test or inspection is to be performed by a testing laboratory accepted in the DSA Laboratory Evaluation and Acceptance (LEA) Program. See section 4-335, 2013 CCR Title 24, Part 1. |
| Test | - Indicates that a test is required | SI | - Indicates that the special inspection is to be performed by a special inspector |
| | | | |
| | | | |

Name of Architect or Engineer in general responsible charge
Chris Warner
 Name of Structural Engineer (When structural design has been delegated)
 **AUG 30 2018**
 Signature of Architect or Structural Engineer _____ date

IDENTIFICATION STAMP
 DIV OF THE STATE ARCHITECT
 APP. # _____
 AC N/A F/LS N/A SS _____
 DATE _____

INCREMENT # DSA File No.:
 Application No.:
 Date Submitted: Revised:
 Revised:

Appendix: Work Exempt from DSA Requirements for Special Inspection or Structural Testing

Exempt items given in IR A-22 or the 2016 CBC (including DSA amendments) and those items identified below with an "X" by the design professional are NOT subject to DSA requirements for the structural tests or special inspections noted. Items marked as exempt shall be identified by either: 1) listing specific details/sheets noted in the spaces provided below OR 2) on the approved construction documents. The project inspector shall verify all construction complies with the approved construction documents.

Exempt by Design Prof.

Exempt by Design Prof.

| | | |
|--|--|---|
| Soils: | 1. Deep foundations acting as a cantilever footing designed based on minimum allowable pressures per 2016 CBC Table 1806A.2 and having no geotechnical report for the following types of structures: free standing sign, scrolling message sign, scoreboard, covered walkway or shade structure with dead load less than 5 psf and other light-weight structures of which the apex is less than 8' above the highest adjacent grade. | X |
| | 2. Shallow foundations meeting the exception item #1 criteria specified in 2016 CBC Section 1803A.2. | X |
| (Optional) List details for applicable exempt items: | | |
| Concrete/Masonry: | | |
| X | 1. Post-installed anchors for the following: 1) exempt non-structural components (e.g., mechanical, electrical, plumbing equipment - see item 7 for "Welding") given in CBC Section 1616A.1.18 (which replaces ASCE 7-10, Section 13.1.4) or 2) interior nonstructural wall partitions meeting criteria listed in exempt item 3 for "Welding." | |
| X | 2. Concrete batch plant inspection is not required for items given in CBC Section 1705A.3.3.2 subject to the requirements and limitations in that section. | |

| | |
|---|---|
| X | Welding: 1. Solid-clad and open-mesh gates with maximum leaf span or rolling section for rolling gates of 10' and apex height less than 8'-0" above lowest adjacent grade. When located above circulation or occupied space below, these gates are not located within 1.5x gate/fence height (max 8'-0") to the edge of floor or roof. |
| X | 2. Handrails, guardrails, and modular or relocatable ramps associated with walking surfaces less than 30" above adjacent grade (excluding post base connections per the 'Exception' language in Section 1705A.2.1); fillet welds cannot be ground flush. |
| X | 3. Non-structural interior cold-formed steel framing spanning less than 15'-0", such as in interior partitions, interior soffits, etc. supporting only self weight and light-weight finishes or adhered tile, masonry, stone, or terra cotta veneer no more than 5/8" thickness and apex less than 20'-0" in height and not over an exit way. Maximum tributary load to a member shall not exceed the equivalent of that occurring from a 10'x10' opening in a 15' tall wall for a header or king stud. |
| X | 4. Manufactured support frames and curbs using hot rolled or cold-formed steel (i.e., light gauge) for mechanical, electrical, or plumbing equipment weighing less than 2000# (equipment only) (connections of such frames to superstructure elements using welding will require special inspection as noted in selected item(s) for section 19, 19.1 and/or 19.2 of listing above). |
| X | 5. Manufactured components (e.g., Toico, B-Line, Alcon, etc.) for mechanical, electrical, or plumbing hanger support and bracing (connections of such components to superstructure elements using welding will require special inspection as noted in selected item(s) for section 19, 19.1 and/or 19.2 of listing above). |
| X | 6. TV Brackets, projector mounts with a valid listing (see DSA IR A-5) and recreational equipment (e.g., playground structures, basketball backstops, etc.) (connections of such elements to superstructure elements using welding will require special inspection as noted in selected item(s) for section 19, 19.1 and/or 19.2 of listing above). |



DSA-103

Issued 9/1/2017

List of Required Structural Tests & Special Inspections - 2016 CBC

INCREMENT #

DSA File No.:

Application No.:

Date Submitted:

Revised:

Revised:

| | |
|--|--|
| X | 3. Masonry retaining walls less than 4'-0" above the top of foundation not supporting a surcharge and free standing nonbearing non-shear masonry walls up to 6'-0" above adjacent grade do not require grout, mortar or masonry core testing or DSA special inspection. |
| X | 4. Epoxy shear dowels in site flatwork. |
| (Optional) List details for applicable exempt items: | |
| X | 7. Any support for exempt non-structural components given in CBC Section 1616A.1.18 (which replaces ASCE 7-10, Section 13.1.4) meeting the following: 1) when supported on a floor/roof, <400# and resulting composite center of mass (including component's center of mass) <= 4' above supporting floor/roof, 2) when hung from a wall or roof/floor, <20# for discrete units or <5 plf for distributed systems. |
| (Optional) List details for applicable exempt items: | |

SECTION 01 5000

TEMPORARY FACILITIES

PART 1 GENERAL

1.01 SCOPE

- A. Provide all required temporary facilities and controls as shown or specified herein and such additional facilities as required for proper performance of the work.
- B. All such temporary facilities shall be located where directed and maintained in a safe and sanitary condition at all times until completion of the contract and then removed from the site for safe disposal.

1.02 TEMPORARY SANITARY FACILITIES

- A. Provide adequate temporary sanitary conveniences for the use of all employees and persons engaged on the work including subcontractors and their employees as required by law, ordinances or regulations of public authorities having jurisdiction.
- B. Toilet Facilities: Enclosed chemical toilets or water closets and urinals, types acceptable to the Architect, Owner and Authorities Having Jurisdiction.
 - 1. If fixtures are used, they shall not be incorporated into the building.
 - 2. Open pit or trench latrines will not be permitted.
- C. Permanent plumbing fixtures of the building shall not be used by construction personnel without the written consent of the Owner.
- D. Sanitary facilities locations shall be acceptable to the Architect and Owner and shall be maintained in a clean and sanitary condition during the entire course of the work. The Contractor shall keep such facilities adequately supplied with toilet paper, paper toweling, etc. as required.
- E. At completion of the work sanitary facilities shall be properly disinfected and all evidence of same removed from the site.

1.03 TEMPORARY ELECTRIC FACILITIES

- A. Provide and maintain during the progress of the work all temporary electrical power and wiring requirements to facilitate the work of all trades and services connected with the work. All payment required by the utility company for the cost of their work in providing the service installation shall be paid for by the Contractor.
- B. The Owner will permit the operation or use of portions of the permanent electrical system to provide light and power during the construction period.
- C. The Contractor shall provide adequate temporary lighting for all work.

1.04 TEMPORARY WATER

- A. The Contractor shall make arrangements for all water required for construction purposes. The Contractor shall furnish and install piping or hose to carry water to every point where needed on the project. All water used on the project shall be potable water.
- B. The Owner will permit the operation or use of portions of the permanent water system to provide water required for construction purposes during the construction period.
- C. Closest availability of water shall be determined by the Contractor.

1.05 CONSTRUCTION EQUIPMENT

- A. The Contractor shall erect, equip and maintain all construction equipment in strict accordance with all applicable statutes, laws, ordinances, rules and regulations of the Owner or other authority having jurisdiction. Provide as required for use of all trades. Hoists and scaffolding shall be installed and erected in accordance with the latest Construction Safety Orders issued by the Division of Industrial Safety, State of California and the Associated General Contractor's "Manual of Accident Prevention in Construction," latest edition.
- B. Scaffolding, staging, runways and similar equipment required for prosecution of the contract shall be provided and maintained by the Contractor.
- C. Hoists and construction elevators required for prosecution of the contract shall be provided and maintained by the Contractor complete with operators, power and signals as required.
- D. The Contractor shall provide, maintain and remove upon completion of the work all temporary rigging, scaffolding, hoisting equipment, rubbish chutes, barricades around openings and excavations, ladders between floors, fences and all other temporary work as required for all work hereunder.
- E. Temporary work shall conform to all the requirements of state, county and local authorities and underwriters which pertain to operation, safety and fire hazard. The Contractor shall furnish and install all items necessary for conformity with such requirements, whether or not called for under the separate divisions of these specifications.

1.06 FENCES AND BARRICADES

- A. Construct and maintain fences, planking, barricades, lights, shoring and warning signs as required by local authorities and state safety ordinances and as required to protect the Owner's property from injury or loss and as necessary for the protection of the public and provide walks around any obstructions made in a public place for carrying on the work covered in this contract. Leave all protection in place and maintain until removal is authorized.
- B. Security fencing shall be located such that clear and unobstructed access is maintained to all existing school facilities.
- C. Relocate fences and barricades as allowed by the progress of the work to minimize the area enclosed. Avoid unnecessary encroachment on existing facilities.

1.07 PARKING AND EXTERIOR STORAGE

- A. The Contractor shall make all arrangements and pay all costs for providing parking facilities for construction personnel, delivery vehicles and authorized visitors.
- B. Where space limitations will not permit adequate facilities within the Owner's property, arrangements for off-property facilities shall be made by the Contractor with city or county authorities or other parties having jurisdiction.
- C. The Contractor shall make similar arrangements for hardstands or other necessary provision for enclosed storage areas for materials, equipment and debris. Locations and perimeters of such facilities shall be subject to the approval of the Architect and authorities having jurisdiction.

1.08 TEMPORARY FIELD OFFICES

- A. Contractor Field Office: Contractor shall provide on the site a temporary field office with a minimum of two individual offices of suitable size for Contractor staff use and for consultations with representatives of the Architect and Owner. Field Office facility shall be:
 - 1. Weatherproof and secure,
 - 2. Provided with adequate lighting, heat, cooling and ventilation.
 - 3. Equipped with a plan rack and plan table, containing a complete set of Contract Documents at all times.
 - 4. Provide conference table and chairs to seat eight (8) persons with such additional furniture as the Contractor may require.
 - 5. Provide a temporary telephone, separate line for fax and internet connection with wireless service as hereinafter specified.
 - 6. Field office location shall be approved by the Architect prior to placing the building on the site.
 - 7. The Architect and Owner and their representatives shall have free access to the field office at all times.
 - 8. The field office shall remain the property of the Contractor and shall be removed from the site upon completion of the work.
 - 9. A suitable office trailer, meeting all foregoing requirements, may be provided for the job office at the Contractor's option.
- B. Inspector Field Office: The Contractor shall provide on the site a temporary job office with a minimum of two individual offices of suitable size for the Inspector of Record. Provide the following facilities:
 - 1. Weatherproof and secure;
 - 2. Provided with adequate lighting, heat, cooling and ventilation.
 - 3. Equipped with a plan rack and plan table and shall contain a complete set of Contract Documents at all times.
 - 4. Sturdy desk with file drawers and chair. The Inspector may provide additional furniture as he or she may require.
 - 5. Copy Machine as hereinafter specified.

6. Provide temporary telephone lines, separate line(s) for fax and all handsets, fax terminal equipment and wireless internet connection with wireless service as hereinafter specified.
7. Inspector's field office location shall be approved by the Architect and Inspector prior to placing the building on the site.
8. The Architect and Owner and their representatives shall have free access to the Inspector's field office at all times. Contractor shall not have access to the Inspector's office.
9. The Inspector's field office shall remain the property of the Contractor and shall be removed from the site upon completion of the work. The Inspector will be responsible for removing his or her files and equipment.

C. Owner will not provide office space or furniture for the Contractor's use.

D. Contractor shall relocate field offices as progress of the work may require.

1.09 TEMPORARY TELEPHONE, FAX, INTERNET CONNECTION AND OFFICE EQUIPMENT

A. Provide temporary telephone, facsimile (fax) service and internet connection in the temporary field offices for use by the Contractor, Owner, Architect, Inspector and their representatives for purposes related to the work. The telephone, fax and internet connection shall be for the use of representatives mentioned above for local calls without charge to the caller.

B. Fax equipment shall be plain paper type.

C. Provide separate telephone lines, fax lines and internet connection as follows:

1. Contractors Field Office: Two (2) Phone lines; One (1) fax line; one (1) internet connection.
2. Inspector's Field Office: Two (2) Phone lines; One (1) fax line; one (1) internet connection.

D. Inspector's Copy Machine: Provide copy machine service in the temporary Inspector's offices for use by the Owner, Architect, Inspector and their representatives for purposes related to the work. Contractor shall not use Inspector's copy machine.

E. Contractor's Copy Machine: Contractor's Option, provide copy machine service in the temporary Field offices for use by the Contractor.

F. Contractor's Responsibility for Costs: Make all arrangements and pay all costs, including service, maintenance and consumable supplies for the specified equipment, until final acceptance of the project.

1.10 TEMPORARY HEATING, COOLING, VENTILATING

A. Provide temporary heating, cooling, dehumidification and ventilation from an approved source whenever necessary for curing, drying, cooling or warming spaces as may be required for the installation of materials or finishes in specified conditions.

B. Maintain facilities or equipment as required for continuous operation of utilities in service. Do not allow interruption of utilities or services. Supply all fuel of types required.

C. Continue temporary services uninterrupted until permanent building systems are completed, capable of maintaining specified conditions without supplemental equipment, and accepted by the Owner.

1.11 CONTINUITY OF SERVICES

- A. Provide temporary panels, raceway, conductors, piping, ductwork and other facilities or equipment as required for continuous operation of utilities in service. Do not allow interruption of utilities.
1. All utility services, such as water, gas, sewers, electricity, data, cable television, communication, clock, bell, or fire protection system serving the project, or any part of it, shall be maintained in continuous operation at all times for the duration of the contract.
 2. Transfer of utilities function to new systems shall be coordinated in writing with the Owner at least two weeks in advance of the proposed date.
 3. Notify and obtain approval from agencies having jurisdiction over utilities prior to transfer of function.
 4. Coordinate provision and removal of temporary facilities with phasing of construction operations as indicated, or as necessary for continuity of service.

1.12 REMOVAL AT COMPLETION

- A. Upon completion of the work, or prior thereto when so directed by the Architect, the Contractor shall remove all temporary facilities, structures and installations from the Owner's property. Similarly, return all exterior areas utilized for temporary facilities to their original natural state or, when called for as part of the Work, complete areas as shown or noted.

PART 2 PRODUCTS

NOT USED

PART 3 EXECUTION

NOT USED

END OF SECTION

SECTION 01 5600

TEMPORARY CONTROLS

PART 1 GENERAL

1.01 SECTION INCLUDES

- A. Barriers, enclosures and fencing.
- B. Dust control.
- C. Water control.
- D. Weed control.
- E. Protection of Installed Work.
- F. Exterior Protection.
- G. Tree and Plant Protection.
- H. Resource Protection.
- G. Progress Cleaning.

1.02 BARRIERS

- A. Construct and maintain any necessary fences, barricades and warning signs as required by local authorities and state safety ordinances and as required to protect the Owner's property from injury or loss. Leave all protection in place and maintain until removal is authorized.
- B. Provide barriers to prevent unauthorized entry to construction areas, to allow for Owner's use of site, and to protect existing facilities and adjacent properties from damage from construction operations and demolition.

1.03 DUST CONTROL

- A. Control dust on the site. Maintain measures to prevent dust and debris from being transported outside the area of Work. Assume responsibility for damage caused by dust to the Work and for damage caused by dust outside the area of Work. Correct damages at Contractor's expense.
- B. Refer to Division 2 sections for additional requirements.

1.04 WATER CONTROL

- A. Grade site to drain. Provide, operate, and maintain pumping equipment as required to maintain excavations and site construction areas free of water.

- B. Protect site from puddling or running water. Provide water barriers as required to protect site from soil erosion.
- C. Do not permit water to stand in locked-in areas of buildings to receive concrete slabs-on-grade, nor on such slabs following their placement. Provide pumping or dewatering facilities and monitor during storm events to prevent these conditions.

1.05 WEED CONTROL

- A. Remove weeds from site that grow over the duration of the project.
- B. Prevent incorporation of organic materials into grading or topdressing.

1.06 PROTECTION OF INSTALLED WORK

- A. Protect installed Work throughout to maintain undamaged. Provide special protection where specified in individual specification sections.
- B. Provide temporary and removable protection for installed Products. Control activity in immediate work area to prevent damage.
- C. Prohibit traffic or storage upon waterproofed or roofed surfaces. If traffic or activity is necessary, obtain recommendations for protection from waterproofing or roofing material manufacturer.
- D. Prohibit traffic from landscaped areas.

1.07 EXTERIOR PROTECTION

- A. Provide temporary weather-tight enclosure of exterior walls for successive areas of building as necessary to:
 - 1. Allow for progress of work;
 - 2. Provide acceptable working conditions;
 - 3. Provide weather protection for materials;
 - 4. Permit effective heating, cooling, dehumidification or ventilation as circumstances may require;
 - 5. Prevent entry of unauthorized persons.
- B. Bear all costs for replacement of damage to existing or new construction, construction materials and equipment from effects of weather, theft and unauthorized entry.

1.08 TREE AND PLANT PROTECTION

- A. Preserve and protect existing trees and plants at site which are designated to remain, and those adjacent to site.
- B. Following consultation with Architect, remove roots and branches which interfere with indicated construction.
 - 1. Employ a qualified tree surgeon to prune and treat cuts.
- C. Provide temporary barriers to a height of six feet, around each, or around each group, of trees and plants.

- D. Protect root zones of trees and plants:
 - 1. Do not allow vehicular traffic and parking.
 - 2. Do not store materials or products.
 - 3. Prevent dumping of refuse or chemically injurious materials or liquids.
 - 4. Prevent puddling or continuous running water.
- E. Carefully supervise excavating, grading and filling, and subsequent construction operations, to prevent damage.
- F. Replace, or suitably repair, trees and plants designated to remain which are damaged or destroyed due to construction operations.

1.09 PROGRESS CLEANING AND WASTE REMOVAL

- A. Maintain areas free of waste materials, debris, and rubbish. Maintain site in a clean and orderly condition. Provide on-going, daily housekeeping and cleanup, including all debris boxes or method for disposal of debris. Contractor will not be permitted to leave debris, trash, leavings, dirt, garbage, rubbish, material containers, etc. on the site. No unsafe and un-workmanlike conditions will be permitted.
- B. Collect and remove waste materials, debris, and rubbish from site weekly and dispose off-site.

1.10 REMOVAL OF CONTROLS

- A. Remove temporary controls prior to inspection.
- B. Clean and repair damage caused by installation or use of temporary work.
- C. Restore existing facilities used during construction to original condition.

PART 2 PRODUCTS

Not Used.

PART 3 EXECUTION

Not Used.

END OF SECTION

SECTION 01 6000

PRODUCT REQUIREMENTS

PART 1 GENERAL

1.01 SECTION INCLUDES

- A. General product requirements.
- B. Transportation, handling, storage and protection.
- C. Product option requirements.
- D. Substitution limitations and procedures.
- E. Procedures for Owner-supplied products.
- F. Spare parts and maintenance materials.

1.02 RELATED SECTIONS

- A. Section 01 4000 - Quality Control: Product quality monitoring.

1.03 DEFINITIONS

- A. Request For Substitution: Requests for changes in products, materials, or equipment required by Contract Documents proposed by the Contractor prior to and after award of the Contract are considered requests for substitutions. The following are not considered substitutions;
 - 1. Revisions to Contract Documents requested by the Owner or Architect.
 - 2. Specified options of products, materials, and equipment included in Contract Documents.

1.04 SUBMITTALS

- A. Proposed Products List: Submit list of major products proposed for use, with name of manufacturer, trade name, and model number of each product.
 - 1. Submit within 15 days after date of Agreement.
 - 2. For products specified only by reference standards, list applicable reference standards.
- B. Product Data Submittals: Submit manufacturer's standard published data. Mark each copy to identify applicable products, models, options, and other data. Supplement manufacturers' standard data to provide information specific to this Project.
- C. Shop Drawing Submittals: Prepared specifically for this Project.
- D. Sample Submittals: Illustrate functional and aesthetic characteristics of the product, with integral parts and attachment devices. Coordinate sample submittals for interfacing work.
 - 1. For selection from standard finishes, submit samples of the full range of the manufacturer's colors, textures, and patterns.

- E. Indicate utility and electrical characteristics, utility connection requirements, and location of utility outlets for service for functional equipment and appliances

PART 2 PRODUCTS

2.01 PRODUCTS

- A. Do not use materials and equipment removed from existing premises, except as specifically permitted by the Contract Documents.
- B. Provide interchangeable components of the same manufacture for components being replaced.
- C. Products or equipment referenced with a manufacturer's name and/or model number shall be provided with all standard materials, components, compliance requirements and features normally furnished for that model or product. These items and requirements are inherent in the specification whether or not individually itemized.
- D. Manufacturer's Requirements: Any deviation from design requirements shown or specified, resulting either from Contractor's or supplier's change of model, or manufacturer's recommendation, or from submitted alternates or accepted substitutions, shall be clearly indicated on the Contractor's submittals. Contractor shall provide all such manufacturer or supplier supplemental requirements at no additional cost.
- E. Owner's Requirements:
 - 1. Pursuant to the requirements of California Public Contract Code 3400, the Owner may designate certain products as "District Standards" in order that a field test or experiment may be made to determine the product's suitability for future use, or in order to match other products in use on a particular public improvement, either completed or in the course of construction.
 - 2. A list of these designated products as may be applicable to the project is contained in the Notice Inviting Bids, as required by PCC 3400. These products shall be provided as specified and are not subject to substitution. All bids shall be deemed to include these listed items as specified without additional costs.
 - 3. In the event of a conflict between the Notice Inviting Bids and the technical specifications for a product's provision for substitutions, the Notice Inviting Bids shall govern.

2.02 PRODUCT OPTIONS

- A. Products Specified by Reference Standards or by Description Only: Use any product meeting those standards or description.
- B. Products Specified by Naming a Single Manufacturer with a Provision for Substitutions: Submit a request for substitution in accordance with specified procedures for products meeting specifications from any manufacturer not named. For such specifications, the Architect is aware of only one manufacturer providing products meeting the specification, pursuant to PCC 3400.
- C. Products Specified by Naming Multiple Manufacturers with a Provision for Substitutions: Submit a request for substitution in accordance with specified procedures for products meeting specifications from any manufacturer not named.

- D. Products Specified by Naming A Single Manufacturer or Multiple Manufacturers without Provision for Substitution: Use only a product of one of the manufacturers named and meeting specifications. No options or substitutions allowed.
- E. Products Specified by Naming A Single Manufacturer or Multiple Manufacturers as listed in the Notice Inviting Bids: Use only a product of one of the manufacturers named and meeting specifications. No options or substitutions allowed

2.03 SPARE PARTS AND MAINTENANCE PRODUCTS

- A. Provide spare parts, maintenance, and extra products of types and in quantities specified in individual specification sections.
- B. Deliver to Project site, prior to final payment.
 - 1. Provide materials list for all items turned over to the Owner including quantities.
 - 2. Deliver items in presence of Owner designated representative to the location identified by the Owner.
 - 3. Obtain Owner designated representative sign-off of materials list attesting to receipt of items in triplicate. Retain one copy, provide one copy to Owner representative receiving items, and submit one copy to Architect.

PART 3 EXECUTION

3.01 LIMITATIONS ON SUBSTITUTIONS SUBMITTED PRIOR TO THE RECEIPT OF BIDS

- A. The Bid shall be based upon the standards of quality established by those items of equipment and/or materials which are indicated in the Contract Documents, including those products designated as "District Standards".
- B. Architect may consider requests for substitutions of specified equipment and/or materials only when requests are received by Architect within fourteen (14) days prior to the date of bid, in conformance with Public Contract Code Section 3400. Do not request substitutions for products designated as "District Standards".
- C. Architect will consider a substitution request only if request is made in strict conformance with provisions of this Section. Request shall be fully responsive to all product requirements of the specified product, including those requirements noted in this section in the article titled PRODUCTS.
- D. Burden of proof of merit of requested substitution is the responsibility of the proposer requesting the substitution.
- E. It is the sole responsibility of the proposer requesting the substitution to establish proper content of submittal for requests for substitutions. Incomplete submittals will be rejected.
- F. When substitution is not accepted, provide specified product.
- G. Substitute products shall not be included within the bid without written acceptance by Addendum.

3.02 LIMITATIONS ON SUBSTITUTIONS SUBMITTED AFTER THE AWARD OF THE CONTRACT

- A. The Contract is based upon the standards of quality established by those items of equipment and/or materials which are indicated in the Contract Documents, including those products designated as "District Standards".
- B. Architect will consider substitution requests received after the established date of the receipt of bids or contract award only when one or more of the following conditions are met and documented:
 - 1. Specified item fails to comply with regulatory requirement.
 - 2. Specified item is no longer manufactured.
 - 3. Specified item, through no fault of the Contractor, unavailable in the time frame required to meet project schedule.
 - 4. Specified item, through subsequent information disclosure, will not perform properly or fit in designated space.
 - 5. Manufacturer declares specified product to be unsuitable for use intended or refuses to warrant installation of product,
 - 6. Substitution would be, in the sole judgment of the Architect, a substantial benefit to the Owner in terms of cost, time, energy conservation, or other consideration of merit.
- C. Notwithstanding other provisions of this section and the above, the Architect may consider a request for substitution after the date of the receipt of bids or contract award, if in the sole discretion of the Architect, there appears to be just cause for such a request. The acceptance of such a late request does not waive any other specified requirement.
- D. Architect will consider a request for substitution after the date of the receipt of bids or contract award only if request is made in strict conformance with provisions of this section. Request shall be fully responsive to all product requirements of the specified product, including those requirements noted in this section in the article titled PRODUCTS.
- E. Substitutions will not be considered when they are indicated or implied on shop drawing or product data submittals, without separate written request, or when acceptance will require revision to the Contract Documents.
 - 1. Review of shop drawings does not constitute acceptance of substitutions indicated or implied on shop drawings.
 - 2. Substitutions will not be considered when requested or submitted directly by subcontractor or supplier.
- F. Contractor's failure or inability to pursue the work promptly or coordinate activities properly shall not establish a cause for consideration of Substitutions.
- G. Burden of proof of merit of requested substitution is the responsibility of the Contractor.
- H. It is the sole responsibility of the Contractor to establish proper content of submittal for requests for substitutions. Incomplete submittals will be rejected.
- I. When substitution is not accepted, provide specified product.
- J. Substitute products shall not be provided without written acceptance by Change Order.

3.03 SUBSTITUTION PROCEDURES

- A. Document each request on Architect's Request For Substitution (RFS) form with complete data substantiating compliance of proposed substitution with Contract Documents. All requests for substitution must be submitted on the specified form which may be obtained from the Architect. Requests received without the Request Form will be rejected.
- B. A request for substitution constitutes a representation that the proposer:
1. Has investigated proposed product and determined that it meets or exceeds the quality level of the specified product.
 2. Will provide the same warranty or bonds for the substitution as for the specified product.
 3. Will coordinate installation of an accepted substitution and make changes to other Work which may be required for the Work to be complete with no additional cost to Owner.
 4. Waives all claims for additional costs or time extension which may subsequently become apparent.
 5. Will reimburse the Owner for services provided by Owner and Architect for review or redesign services associated with re-approval by authorities.
- C. Regulatory Requirements: Proposer requesting the substitution shall be responsible for obtaining all regulatory approvals required for proposed substitutions.
1. All regulatory approval shall be obtained for proposed substitutions prior to submittal of substitution request to Architect, unless Architect participation is required by the regulating agency.
 2. All substitutions that affect structural safety, fire and life safety, access compliance or energy (as applicable) shall be submitted to Division of State Architect for review and approval.
 3. All costs incurred by the Owner in obtaining regulatory approvals for proposed substitutions, including the costs of the Architect and any authority having jurisdiction over the project shall be reimbursed to the Owner. Costs of these services shall be reimbursed regardless of final acceptance or rejection of substitution.
- D. Substitution Submittal Procedure:
1. Submit one original signature copy of only the Request For Substitution Form included in this Project Manual for consideration. Forms provided by proposer or other agencies or organizations are not acceptable. Limit each request to one proposed substitution.
 2. Submit shop drawings, product data, and certified test results attesting to the proposed product equivalence, including:
 - a. Statement of cause for substitution request.
 - b. Identify product by specification section and article number.
 - c. manufacturer's name, address, and phone number.
 - d. List of fabricators, suppliers, and installers as appropriate.
 - e. List of similar Projects where proposed products have been used, date of installation and names of Architect and Owner.
 - f. Confirmation of regulatory approvals
 - g. Product data, including drawings and product samples.
 - h. Fabrication and installation procedures.
 - i. Comparison of the qualities of the proposed substitution with that specified.
 - j. Cost data comparing the proposed substitution with the product specified.
 - k. Any required license fees or royalties.
 - l. Availability of maintenance service and source of replacement materials.

- m. Coordination information, including a list of changes or modifications needed to other items of work that will be required to accommodate Proposed substitution.
- n. Statement on the Substitution's effect on the Construction Schedule.
- o. Written certification by the proposer that the Substitution is equal or better in every respect to that required by the contract Documents and that substitution will perform adequately in the application intended.
- p. Written certification that the proposer will pay for all permits, fees, and costs required to implement the substitution, and including waiver of all claims for additional costs or time extension which may subsequently become apparent, and reimbursement of Owner and Architect for review or redesign services associated with re-approval by authorities.

3.04 ARCHITECT'S REVIEW OF SUBSTITUTIONS

- A. The Architect will accept or reject proposed substitutions within fourteen (14) days of receipt of request.
- B. If a decision on a substitution cannot be made within the time allocated, the product specified shall be used.
- C. No extension of bid period or contract time will be made for substitution review.
- D. Final acceptance of a substitution submitted prior to the date established for the receipt of bids will be in the form of a Bid Clarification or Addendum.
- E. Final acceptance of a substitution submitted after the award of the contract will be in the form of an Architect Supplemental Instruction and/or Construction Change Direction.
- F. Architect/Engineer shall be the judge of the acceptability of the proposed substitution. Architect's decision on substitution requests is final and does not require documentation or justification.
- G. Rejection Of Substitution Request: Any of the following reasons shall be cause for rejection, all as determined by the Architect;
 - 1. Vagueness or incompleteness of Substitution submittal,
 - 2. Insufficient data, failure to meet specified requirements, (including warranty).
 - 3. Qualification of the requirements of the Substitution Form, including modification of any of the requirements.
- H. The Architect/Engineer will notify Contractor in writing of decision to accept, accept as noted, or not accept the request for substitution.
- I. Substitute products shall not be ordered or installed without written acceptance.
- J. Owner shall receive full benefit of any cost reduction as a result of any request for substitution.
- K. Provide submittals for accepted substitutions in accordance with specified requirements of the respective section and provisions of Section 01 2500.
 - 1. An accepted substitution is not acceptable as a submittal under Section 01 2500. Provide separate submittals for each review.

3.05 OWNER-SUPPLIED PRODUCTS

- A. See Section 01 1100- Summary for identification of Owner-supplied products.
- B. Owner's Responsibilities:
 - 1. Arrange and pay for product delivery to site.
 - 2. On delivery, inspect products jointly with Contractor.
 - 3. Submit claims for transportation damage and replace damaged, defective, or deficient items.
 - 4. Arrange for manufacturers' warranties, inspections, and service.
- C. Contractor's Responsibilities:
 - 1. Receive and unload products at site; inspect for completeness or damage jointly with Owner.
 - 2. Handle, store, install and finish products.
 - 3. Repair or replace items damaged after receipt.
 - 4. Coordinate installation with other trades.

3.06 TRANSPORTATION AND HANDLING

- A. Transport and handle products in accordance with manufacturer's instructions.
- B. Promptly inspect shipments to ensure that products comply with requirements, quantities are correct, and products are undamaged.
- C. Provide equipment and personnel to handle products by methods to prevent soiling, disfigurement, or damage.

3.07 STORAGE AND PROTECTION

- A. Store and protect products in accordance with manufacturers' instructions.
- B. Store with seals and labels intact and legible.
- C. Store sensitive products in weather tight, climate controlled, enclosures in an environment favorable to product.
- D. For exterior storage of fabricated products, place on sloped supports above ground.
- E. Cover products subject to deterioration with impervious sheet covering. Provide ventilation to prevent condensation and degradation of products.
- F. Store loose granular materials on solid flat surfaces in a well-drained area. Prevent mixing with foreign matter.
- G. Provide equipment and personnel to store products by methods to prevent soiling, disfigurement, or damage.
- H. Arrange storage of products to permit access for inspection. Periodically inspect to verify products are undamaged and are maintained in acceptable condition.
- I. Provide bonded off-site storage and protection only when site does not permit on-site storage or protection. Obtain Owner's permission prior to initiating such off-site storage.

END OF SECTION

(REQUEST FOR SUBSTITUTION FORM FOLLOWS)

Request for Substitution

{Projects.Name}
Project Number: {Projects.Number}
DSA Application: {LegalDocInfo.NotaryStateOf}
DSA File: {LegalDocInfo.NotaryName}

Specification Title: _____ Product Description: _____
Specification Section: _____ Article/Paragraph: _____

Architect will consider substitution requests received after the date established as deadline for substitution request only when one or more of the following conditions are met and documented; indicate one or more conditions which apply:

- Specified item fails to comply with regulatory requirement.
- Specified item is no longer manufactured.
- Specified item, through no fault of the Contractor, unavailable in the time frame required to meet project schedule.
- Specified item, through subsequent information disclosure, will not perform properly or fit in designated space.
- Manufacturer declares specified product to be unsuitable for use intended or refuses to warrant installation of product.
- Substitution would be a substantial benefit to the Owner in terms of cost, time, energy conservation, or other consideration of merit.

Explain benefit (required): _____

Proposed Product Name (include specific model number): _____

Manufacturer: _____ Phone: _____

Address: _____

Installer: _____

Address: _____ Phone: _____

History: New product 2-5 years old 5-10 years old More than 10 years old

Difference between proposed substitution and specified product: _____

Attached comparative table. Include point-by-point comparison of each article number. **REQUIRED**

Similar Installation:

Project: _____ Architect: _____

Address: _____ Owner: _____

_____ Date Installed: _____

Proposed substitution affects other parts of Work? No Yes; Explain: _____

Savings to Owner for accepting substitution: _____ (\$ _____).

Proposed substitution changes Contract Time? No Yes; [Add] or [Deduct] _____ days.

Substitution Request

(Continued)

As outlined in Specification Section 01 6000, a request for substitution constitutes a representation that the proposer:

- Has investigated proposed product and determined that it meets or exceeds the quality level of the specified product.
- Will provide the same warranty or bonds for the substitution as for the specified product.
- Will coordinate installation of an accepted substitution and make changes to other Work which may be required for the Work to be complete with no additional cost to Owner.
- Waives all claims for additional costs or time extension which may subsequently become apparent.
- Will reimburse Owner for services provided by Owner and Architect associated with re-approval by authorities.

{Company.Name} Representative Printed Name: _____

{Company.Name} Representative Signature: _____

Date Submitted from {Company.Name} to Architect: _____

Supporting Data Attached: Drawings Product Data Samples Tests Reports

Additional comments: _____

Architect's review and action:

- Substitution approved - Make submittals in accordance with Specification Section 01 3300.
- Substitution approved as noted - Make submittals in accordance with Specification Section
- 01 3300. Substitution rejected - Use specified materials.
- Substitution Request received too late - Use specified materials.

Reviewed by: _____ Date: _____

SECTION 01 6116

VOLATILE ORGANIC COMPOUND (VOC) RESTRICTIONS

PART 1 GENERAL

1.01 SUMMARY

- A. VOC restrictions for product categories listed below under "DEFINITIONS."
 - 1. California Code of Regulations, Title 24, Part 11 California Green Building Standards Code, "CAL-Green".
- B. All products of each category that are installed in the project must comply; applicable laws and ordinances do not allow for partial compliance.
- C. Listing of a product in these specifications shall not be construed as a solicitation or requirement to use any product or combination of products in violation of the requirements of South Coast Air Quality Management District Rule No.1168, as described in Rule 1168(g).
 - 1. If a listed product does not meet the requirements of this rule, request approval for use of an alternate product by the same or another manufacturer meeting the requirements of this rule.
 - 2. Do not use products which do not meet the requirements of this rule.

1.02 RELATED REQUIREMENTS

- A. Divisions 01 through 33 contain related requirements specific to the work of each of these Sections. Requirements may or may not include reference to this section.
- B. Section 01 8113 "Sustainable Design Requirements".

1.03 DEFINITIONS

- A. VOC-Restricted Products: All products of each of the following categories when installed or applied on-site:
 - 1. Adhesives, sealants, and sealer coatings, regardless of specification section or division.
 - 2. Paints and coatings.
 - 3. Carpet and resilient flooring.
 - 4. Composite wood products; plywood, particleboard, wood fiberboard.
- B. Adhesives: All gunnable, trowelable, liquid-applied, and aerosol adhesives, whether specified or not; including flooring adhesives, resilient base adhesives, and pipe jointing adhesives.
- C. Sealants: All gunnable, trowelable, and liquid-applied joint sealants and sealant primers, whether specified or not; including firestopping sealants and duct joint sealers.

1.04 REFERENCE STANDARDS

- A. California Code of Regulations, Title 24, Part 11 California Green Building Standards Code, "CAL-Green".
- B. Low-Emitting Materials Product List; California Collaborative for High Performance Schools (CHPS); current edition at www.chps.net.
- C. CRI (GLCC) - Green Label Testing Program - Approved Product Categories for Carpet Cushion; Carpet and Rug Institute; Current Edition.

- D. CRI (GLP) - Green Label Plus Carpet Testing Program - Approved Products; Carpet and Rug Institute; Current Edition.
- E. GEI (SCH) - GREENGUARD "Children and Schools" Certified Products; GREENGUARD Environmental Institute; current listings at www.greenguard.org.
- F. GreenSeal GS-36 - Commercial Adhesives; Green Seal, Inc.
- G. SCAQMD 1168 - South Coast Air Quality Management District Rule No.1168; current edition; www.aqmd.gov.
- H. SCS (CPD) - SCS Certified Products; Scientific Certification Systems; current listings at www.scs-certified.com.

1.05 SUBMITTALS

- A. See Section 01 3300 - Submittals Procedures.
- B. Evidence of Compliance: Submit for each different product in each applicable category.
 - 1. Identify evidence submittals with the words "CAL-Green VOC Compliance Report".
- C. Product Data: For each VOC-restricted product used in the project, submit product data showing compliance, except when another type of evidence of compliance is required.
- D. Installer Certifications for Accessory Materials: Require each installer of any type of product, (not just the products for which VOC restrictions are specified) to certify that either 1) no adhesives, joint sealants, paints, coatings, or composite wood or agrifiber products have been used in the installation of his products, or 2) that such products used comply with these requirements.
 - 1. Use the form following this section for installer certifications.

1.06 QUALITY ASSURANCE

- A. A. Testing Agency Qualifications: Independent firm specializing in performing testing and inspections of the type specified in this section.

PART 2 PRODUCTS

2.01 MATERIALS

- A. General: Provide only products having volatile organic compound (VOC) content not greater than required by South Coast Air Quality Management District Rule No.1168 and less where required by code.
 - 1. These products may be specified in multiple sections throughout these specifications.
- B. Adhesives, including carpet: Comply with Title 24, Part 11, Table 5.504.4.1.
 - 1. Evidence of Compliance: Acceptable types of evidence are:
 - a. Report of laboratory testing performed in accordance with requirements.
 - b. Published product data showing compliance with requirements.
 - c. Certification by manufacturer that product complies with requirements.
- C. Joint Sealants: Comply with Title 24, Part 11, Table 5.504.4.2.
 - 1. Evidence of Compliance: Acceptable types of evidence are:
 - a. Report of laboratory testing performed in accordance with requirements.
 - b. Published product data showing compliance with requirements.
 - c. Certification by manufacturer that product complies with requirements.

- D. Aerosol Adhesives: Comply with Title 24, Part 11, Table 5.504.4.1. and California Code of Regulations Title 17, Section 94507.
1. Evidence of Compliance: Acceptable types of evidence are:
 - a. Current GreenSeal Certification.
 - b. Report of laboratory testing performed in accordance with GreenSeal GS-36 requirements.
 - c. Published product data showing compliance with requirements.
- E. Paints and Coatings: Comply with Title 24, Part 11, Table 5.504.4.3; California Air Resources Board, Architectural Coatings Suggested Control Measure, February 1, 2008.
1. Determination of VOC Content: Testing and calculation in accordance with 40 CFR 59, Subpart D (EPA Method 24), exclusive of colorants added to a tint base and water added at project site; or other method acceptable to authorities having jurisdiction.
 - a. Evidence of Compliance: Acceptable types of evidence are:
 - 1) Report of laboratory testing performed in accordance with requirements.
 - 2) Published product data showing compliance with requirements.
 - 3) Certification by manufacturer that product complies with requirements.
 - b. Provide coatings that comply with the most stringent requirements specified in the following:
 - 1) 40 CFR 59, Subpart D--National Volatile Organic Compound Emission Standards for Architectural Coatings.
 - 2) South Coast Air Quality Management District Rule No.1168.
- F. Carpet: Comply with Title 24, Part 11, 5.504.4.4; meet testing and product requirements of one of the following:
1. Carpet & Rug Institute "Green Label Plus".
 2. California Department of Public Health Standard Practice for testing of VOC's (Specification 01350).
 3. NSF/ANSI 140 at Gold Level.
 4. Scientific Certification Systems Sustainable Choice.
 5. All carpet cushion installed shall meet requirements of Carpet & Rug Institute "Green Label Program".
 6. All carpet cushion installed shall meet requirements of Title 24, Part 11, Table 5.504.4.1.
- G. Resilient Flooring Products: Comply with Title 24, Part 11, 5.504.4.6. Fifty percent of floor area receiving resilient flooring shall have flooring complying with VOC emission limits in CHPS 2009 criteria and listed on the Low Emitting Materials List or Product Registry or certified under the Resilient Floor Covering Institute (RFCI) FloorScore program.
1. Provide documentation verifying that finish materials are certified to meet pollutant limits. Acceptable types of evidence are:
 - a. Published product data showing compliance with requirements.
 - b. Inclusion on one of the following lists:
 - 1) www.chps.net/dev/drupal/node/381
 - 2) www.rfci.com/int_FS-ProdCert.htm
 - 3) www.greenguard.org/default.aspx?tabid=135
 - 4) Other method acceptable to enforcing agency.
- H. Composite Wood Products: Comply with Title 24, Part 11, Table 5.504.4.5 formaldehyde limits for hardwood plywood, particleboard, and medium density fiberboard composite wood products.
1. Title 24, Part 11, Table 5.504.4.5 Composite Wood Products Maximum Formaldehyde Emissions in Parts per Million.

| PRODUCT | CURRENT LIMIT (Effective July 1, 2012) |
|---------------------------------|--|
| Hardwood Plywood veneer core | 0.05 |
| Hardwood Plywood composite core | 0.05 |
| Particleboard | 0.09 |
| Medium Density Fiberboard | 0.11 |
| Thin Medium Density Fiberboard | 0.13 |

2. Evidence of Compliance: Acceptable types of evidence are:
 - a. Chain of custody certifications
 - b. Published product data showing compliance with requirements.
 - c. Certification by manufacturer that product complies with requirements.
 - d. Other method acceptable to enforcing agency.

PART 3 EXECUTION

3.01 FIELD QUALITY CONTROL

- A. Owner reserves the right to reject non-compliant products, whether installed or not, and require their removal and replacement with compliant products at no extra cost to Owner.
- B. All additional costs to restore indoor air quality, including fines by authorities, due to installation of non-compliant products will be borne by Contractor.

3.02 RESTRICTED COMPONENTS

- A. Restricted Components:
 1. Paints and coatings shall not contain any of the following:
 - a. Acrolein.
 - b. Acrylonitrile.
 - c. Antimony.
 - d. Benzene.
 - e. Butyl benzyl phthalate.
 - f. Cadmium.
 - g. Di (2-ethylhexyl) phthalate.
 - h. Di-n-butyl phthalate.
 - i. Di-n-octyl phthalate.
 - j. 1,2-dichlorobenzene.
 - k. Diethyl phthalate.
 - l. Dimethyl phthalate.
 - m. Ethylbenzene.
 - n. Formaldehyde.
 - o. Hexavalent chromium.
 - p. Isophorone.
 - q. Lead.
 - r. Mercury.
 - s. Methyl ethyl ketone.
 - t. Methyl isobutyl ketone.

- u. Methylene chloride.
- v. Naphthalene.
- w. Toluene (methylbenzene).
- x. 1,1,1-trichloroethane.
- y. Vinyl chloride.

B. The following tables are taken from South Coast Air Quality Management District Rule No.1168 and are believed accurate at the time of publication. All products used shall comply with the limits of Rule No. 1168. In the event of discrepancy between these values and those of Rule No. 1168, those of Rule No. 1168 shall prevail.

C. Table 5.504.4.1 ADHESIVE VOC LIMIT

| Architectural Applications | Current VOC Limit |
|-------------------------------------|-------------------|
| Indoor Carpet Adhesives | 50 |
| Carpet Pad Adhesives | 50 |
| Outdoor Carpet Adhesives | 150 |
| Wood Flooring Adhesives | 100 |
| Rubber Floor Adhesives | 60 |
| Subfloor Adhesives | 50 |
| Ceramic Tile Adhesives | 65 |
| VCT and Asphalt Tile Adhesives | 50 |
| Dry Wall and Panel Adhesives | 50 |
| Cove Base Adhesives | 50 |
| Multipurpose Construction Adhesives | 70 |
| Structural Glazing Adhesives | 100 |
| Single Ply Roof Membrane Adhesives | 250 |

D. Table 5.504.4.1 Continued

| | VOC Limits and Effective Dates ** | ** The specified limits remain in effect unless revised limits are listed in subsequent columns. | | |
|---------------------------------|--------------------------------------|--|--------|--------|
| Specialty Applications | Current VOC Limit | 1-1-05 | 7-1-05 | 1-1-07 |
| PVC Welding | 510 | | | |
| CPVC Welding | 490 | | | |
| ABS Welding | 400 | | 325 | |
| Plastic Cement Welding | 350 | 250 | | |
| Adhesive Primer for Plastic | 650 | | 550 | |
| Computer Diskette Manufacturing | 350 | | | |

| | | | | |
|--|-----|--|--|-----|
| Contact Adhesive | 80 | | | |
| Special Purpose Contact Adhesive | 250 | | | |
| Tire Retread | 100 | | | |
| Adhesive Primer for Traffic Marking Tape | 150 | | | |
| Structural Wood Member Adhesive | 140 | | | |
| Sheet Applied Rubber Lining Operations | 850 | | | |
| Top and Trim Adhesive | 540 | | | 250 |

E. Table 5.504.4.1 Continued

| | |
|--|-------------------|
| For adhesives, adhesive bonding primers, or any other primer not regulated by the above two tables and applied to the following substrates, the following limits shall apply | |
| Substrate Specific Applications | Current VOC Limit |
| Metal to Metal | 30 |
| Plastic Foams | 50 |
| Porous Material (Except Wood) | 50 |
| Wood | 30 |
| Fiberglass | 80 |

F. Table 5.504.4.2 SEALANT VOC LIMIT

| | |
|---|-------------------|
| If an adhesive is used to bond dissimilar substrates together the adhesive with the highest VOC content shall be allowed. | |
| Sealant | Current VOC Limit |
| Architectural | 250 |
| Marine Deck | 760 |
| Nonmembrane Roof | 300 |
| Roadway | 250 |
| Single Ply Roof Membrane | 450 |
| Other | 420 |

| | |
|-----------------|-------------------|
| Sealant Primers | Current VOC Limit |
|-----------------|-------------------|

| | |
|--|-----|
| Architectural Porous | 250 |
| Architectural Non-Porous | 775 |
| Modified Bituminous | 500 |
| Marine Deck | 760 |
| Other | 750 |
| For low-solid adhesives or sealants the VOC limit is expressed in grams per liter of material as determined in paragraph (b)(32); for all other adhesives and sealants, VOC limits are expressed as grams of VOC per liter of adhesive or sealant less water and less exempt compounds as determined in paragraph (b)(31). | |

G. Paints and Coatings: Architectural Paints and Coatings shall comply with VOC limits in Table 1 of ARB Architectural Coatings Suggested Control Measure, California Code of Regulations, Title 24, Part 11 California Green Building Standards Code, "CAL-Green" Table 5.504.4.3. All products used in this category shall comply with these limits, unless more stringent local and regional rules apply.

H. **Table 5.504.4.3 VOC CONTENT LIMITS FOR ARCHITECTURAL COATINGS (See Notes 2 & 3 below)**

| Grams of VOC per Liter of Coating, less water and less exempt compounds. | |
|--|-----------------------------------|
| COATING CATEGORY | Current VOC Limit 1/1/2012 |
| Flat Coatings | 50 |
| Nonflat Coatings | 100 |
| Nonflat High Gloss Coatings | 150 |
| Specialty Coatings | |
| Aluminum Roof Coatings | 400 |
| Basement Specialty Coatings | 400 |
| Bituminous Roof Coatings | 50 |
| Bituminous Roof Primers | 350 |
| Bond Breakers | 350 |
| Concrete Curing Compounds | 350 |
| Concrete / Masonry Sealers | 100 |
| Driveway Sealers | 50 |
| Dry Fog Coatings | 150 |
| Faux Finishing Coatings | 350 |
| Fire Resistive Coatings | 350 |
| Floor Coatings | 100 |
| Form-Release Compounds | 250 |
| Graphic Arts Coatings (Sign Paints) | 500 |
| High-Temperature Coatings | 420 |
| Industrial Maintenance Coatings | 250 |
| Low Solids Coatings (See Note 1 above) | 120 |
| Magnesite Cement Coatings | 450 |

| | |
|---|-----|
| Mastic Texture Coatings | 100 |
| Metallic Pigmented Coatings | 500 |
| Multicolor Coatings | 250 |
| Pretreatment Wash Primers | 420 |
| Primers, Sealers and Undercoaters | 100 |
| Reactive Penetrating Sealers | 350 |
| Recycled Coatings | 250 |
| Roof Coatings | 50 |
| Rust Preventative Coatings | 250 |
| Shellacs: | |
| Clear | 730 |
| Opaque | 550 |
| Specialty Primers, Sealers and Undercoaters | 100 |
| Stains | 250 |

| | |
|--------------------------|-----|
| Stone Consolidants | 450 |
| Swimming Pool Coatings | 340 |
| Traffic Marking Coatings | 100 |
| Waterproofing Membranes | 250 |
| Wood Coatings | 275 |
| Wood Preservatives | 350 |
| Zinc Rich Primers | 340 |

1. Note 1: Grams of VOC per liter of coating including water and including exempt compounds
2. Note 2: Not Applicable
3. Note 3: Values in this table are derived from those specified by the California Air Resources Board, Architectural Coatings Suggested Control Measure, February 1, 2008. More information is available from the Air Resources Board.

END OF SECTION

SECTION 01 6116.01

ACCESSORY MATERIAL VOC CONTENT CERTIFICATION FORM

1.01 FORM

- A. Identification:
1. Project Name: _____
 2. Project No.: _____
 3. Architect: _____
- B. Use of This Form:
1. Because installers are allowed and directed to choose accessory materials suitable for the applicable installation, there is a possibility that such accessory materials might contain VOC content in excess of that permitted, especially where such materials have not been explicitly specified.
 2. Contractor is required to obtain and submit this form from each installer of work on this project.
 3. For each product category listed, circle the correct words in brackets: either [HAS] or [HAS NOT].
 4. If any of these accessory materials has been used, attach to this form product data and MSDS sheet for each such product.
- C. VOC content restrictions are specified in Section 01 6116.

2.01 PRODUCT CERTIFICATION

- A. I certify that the installation work of my firm on this project:
1. [HAS] [HAS NOT] required the use of any ADHESIVES.
 2. [HAS] [HAS NOT] required the use of any JOINT SEALANTS.
 3. [HAS] [HAS NOT] required the use of any PAINTS OR COATINGS.
 4. [HAS] [HAS NOT] required the use of any COMPOSITE WOOD or AGRIFIBER PRODUCTS.
- B. Product data and MSDS sheets are attached.

3.01 CERTIFIED BY: (Installer/Manufacturer/Supplier Firm)

- A. Firm Name: _____
- B. Print Name: _____
- C. Signature: _____
- D. Title: _____ (officer of company)
- E. Date: _____

END OF SECTION

SECTION 01 7419

CONSTRUCTION WASTE MANAGEMENT

PART 1 GENERAL

1.01 RELATED DOCUMENTS:

- A. Drawings and general provisions of each prime Contract, including General and Supplementary Conditions and other Division 01 Specification Sections, apply to this Section.

1.02 SUMMARY:

- A. Contractor shall implement procedures to divert 75% of construction waste. As many of the waste materials as economically feasible shall be reused, salvaged, or recycled. Waste disposal in landfills shall be minimized.
- B. The Contractor shall develop a Waste Management Plan as defined in this Section and submit for review by the Owner, Construction Manager, and Architect.

1.03 DEFINITIONS

- A. Waste Materials: construction materials that are excess to the contract requirements and which can not be effectively used in the Work.
- B. Salvage Materials: waste materials or materials that exist on the site that can be reused, either on site or by another entity.
- C. Recyclable Waste: waste materials that exist on site or are generated during the construction process that can be recycled/remanufactured into another material.
- D. Categories of salvageable or recyclable waste include the following:
 1. Concrete, Masonry, and Other Inert Fill Material: concrete, brick, rock, broken up asphalt pavement, clay, and other inert (non-organic) materials.
 2. Metals: metal scrap including iron, steel, copper, brass, and aluminum; includes beverage containers, packaging materials (such as metal banding), fencing, reinforcing bar, wiring, plumbing, etc.
 3. Untreated Wood: unpainted, untreated dimensional lumber, wood edging, wood shipping pallets, etc. Does not include pressure treated or creosote treated wood.
 4. Engineered Wood Products: plywood, oriented strand board, "Masonite", particleboard, manufactured trusses and beams, and glue-laminated timbers.
 5. Gypsum Wallboard: excess drywall construction materials including cuttings, other scrap, and excess materials.
 6. Cardboard: clean, corrugated cardboard such as used for packaging, etc.
 7. Paper Goods:
 8. Office paper: includes any paper, such as manufacturer instruction, specification sheets, files, correspondence, packaging, stiffeners, etc.
 9. Newsprint: shredded or whole newspaper goods.

10. Plastic: beverage containers, packaging materials (such as polystyrene "peanuts" and expanded polystyrene), containers (other than those used for hazardous materials), vinyl products, etc.
11. Glass: includes glass beverage containers, and recyclable glass building materials.
12. Insulation: rigid foam, batt, and loose fill insulation materials.
13. Carpet: face fiber, backing, padding, and carpet cushion scrap.
14. Paints: unused portions of paints and coatings applied on-site.
15. Fabric: uncontaminated fabric scraps.
16. Rubber: uncontaminated rubber scraps, including but not limited to recycled-content rubber flooring, rubber edging, tires that are no longer serviceable, etc.
17. Other: any additional materials identified on-site to be valued for salvage, reuse, or recycling by the Contractor, Owner, Construction Manager, or Architect.

- E. Non-Recyclable Waste: All waste materials that are not able to be recycled, due to contamination, lack of recycling facilities or salvage options, or high cost.
- F. Source Separated: Materials that are separated on-site by category.
- G. Co-Mingled: Several types of construction waste that are combined in a single container. Co-mingling of recycling waste must be approved by the identified recycling facility.
- H. Hazardous Waste: Any substance whose handling and/or disposal is regulated as hazardous waste by local, state, or federal authorities.

1.04 QUALITY ASSURANCE

- A. Regulatory Requirements: Comply with all applicable federal, state, and local ordinance and regulation requirements for recycling and waste management.
- B. Disposal Sites, Recyclers, and Waste Materials Processors: Use only facilities properly permitted by state and local authorities.
- C. Preconstruction Waste Management Conference: Prior to beginning work at the site, schedule and conduct a conference to review the Construction Waste Management Plan and discuss procedures, schedules and specific requirements for waste materials recycling and disposal. Discuss coordination and interface between the Contractor and other construction activities. Identify and resolve problems with compliance with requirements. Record minutes of the meeting, identifying all conclusions reached and matters requiring further resolution.
1. Plan Revision: Make any revisions to the Construction Waste Management Plan agreed upon during the meeting and incorporate resolutions agreed to be made subsequent to the meeting. Submit the revised plan to the Contracting Officer's Representative for approval.
- D. Implementation:
1. Designate an on-site party responsible for instructing workers and implementing the Construction Waste Management Plan.
 2. Distribute copies of the Construction Waste Management Plan to the job site foreman and each subcontractor.
 3. Include waste management and recycling in worker orientation.
 4. Provide on-site instruction on appropriate separation, handling, recycling, and salvaging methods to be used by all parties at the appropriate stages of the work at the site.

5. Prominently display Waste Management Plan and clearly mark all containers and areas on site dedicated to source separation.
6. Include waste management and recycling discussion in pre-fabrication meetings with subcontractors and fabricators.
7. Also include discussion of waste management and recycling in regular job meetings and job safety meetings conducted during the course of work at the site.

1.05 STORAGE AND HANDLING

- A. Salvage Materials: Provide protective handling and storage as required for all items identified for salvage and reuse by the Owner, Construction Manager, or Architect.
- B. Recyclable Waste: Remove all recyclable materials, as identified in the Waste Management Plan, from the work location to approved containers daily. Failure to remove waste materials will be considered cause for withholding payment and/or termination of Contract.
- C. Provide separate collection containers as required by recycling haulers and to prevent contamination of materials, including protection from rain as applicable.
- D. Replace loaded containers with empty ones as demand requires but not less than weekly.
- E. Handling: Deposit all indicated recyclable materials in the containers in a clean (no mud, adhesives, solvents, petroleum contamination), debris-free condition. Do not deposit contaminated materials into the containers until such time as such materials have been cleaned.
- F. If contamination chemically combines with the material so that it cannot be cleaned, do not deposit into the recycle containers.

1.06 PROJECT/SITE CONDITIONS

- A. Environmental Requirements: Transport recyclable waste materials from the Work Area to the recycle containers and carefully deposit in the containers in a manner to minimize noise and dust. Close container covers immediately after materials are deposited. Do not place recyclable waste materials on the ground adjacent to a container.
- B. Existing Conditions: Coordinate with "Instructions to Bidders" and "Supplementary Conditions".

1.07 SUBMITTALS

- A. Construction Waste Management Plan: Contractor must submit complete Construction Waste Management Plan for review within 30 days from the Notice to Proceed.

PART 2 PRODUCTS

2.01 CONSTRUCTION WASTE MANAGEMENT PLAN

- A. Construction Waste Management Plan: Contractor shall develop a construction waste management plan indicating proposed methods for collection, segregation, and removal of all construction wastes and debris produced by the work of this Contract, including all costs associated with this plan. Those waste materials produced during the course of this Contract that can be recycled cost-effectively, shall be. The Waste Management Plan shall include, at a minimum, the following:

1. Provide an analysis of jobsite waste to be generated, including types and quantities.
 2. Provide strategies for salvage, reuse, or recycling for a minimum of all materials listed below. Include additional waste materials that are deemed cost-effective to salvage, reuse, or recycle. See "Definitions" above for material categories.
 3. Provide documentation to justify decision not to recycle any items listed below.
 4. Show compliance with applicable state and local ordinances and regulations.
 5. Include a list of recycling facilities to which indicated recyclable materials will be distributed for disposal.
 6. Identify materials that are not recyclable or otherwise conservable that must be disposed of in a landfill or other means acceptable under governing State and local regulations.
 7. List permitted landfills and/or other disposal means to be employed.
 8. Indicate any instances where compliance with requirements of this Section does not appear to be possible and request resolution from the Architect.
- B. Waste Materials: The following materials shall be salvaged or recycled according to this specification. Strategies for salvage and recycling shall be identified in the Waste Management Plan as required above.
1. Salvage Materials: Identify materials existing on site that are candidates for salvage and reuse, either on this Project or through sale or donation to local organizations.
 2. Recyclable Materials: The following materials, at a minimum, shall be salvaged or recycled. Applies to all such listed waste materials produced during the course of this Contract.
 - a. Concrete, Masonry, and Other Inert Fill Material
 - b. Metals
 - c. Untreated Wood
 - d. Gypsum Wallboard Scrap
 - e. Cardboard
 - f. Paper Goods
 - g. Beverage Containers
 - h. Plastic
 - i. Glass
 - j. Carpet
- C. Delivery Receipts: Maintain copies of delivery receipts for waste materials salvaged and sent to permitted waste materials processors or recyclers that indicate the location and name of firm accepting recyclable waste materials, types of materials, net weights of each type, date of delivery and value of materials.
- D. Maintain working copy of Construction Waste Management Plan at site for review by Owner, Construction Manager, Architect, and all Trades involved in Project.

PART 3 EXECUTION

3.01 WASTE MANAGEMENT

- A. General: Implement waste management procedures in accordance with approved construction waste management plan. Maintain procedure throughout the life of this Contract.
- B. Source Separation: Separate, store, protect, and handle at the project site all identified recyclable and salvageable waste products to prevent contamination of materials and maximize recyclability and salvageability of materials.
- C. Collection: Arrange for timely pickups from the site or deliveries to approved recycling facilities of designated waste materials to keep construction site clear and prevent

contamination of recyclable materials. Maintain records accessible to the Contracting Officer's Representative for verification of construction waste materials recycling.

- D. Delivery Receipts: Keep and maintain records of all deliveries to recycling facilities and all pickups of waste materials at the site by others as specified above.
- E. Salvage and Reuse: Identify salvage and reuse options for all materials that are deemed to be reusable, but will not be reused on this Project.
- F. Non-Recyclable Waste: Collect and segregate non-recyclable waste for delivery to a permitted landfill site.
- G. Hazardous Waste: Control and dispose of hazardous waste in accordance with local, state, and federal regulations.

END OF SECTION

SECTION 01 7500

STARTING OF SYSTEMS

PART 1 GENERAL

1.01 SECTION INCLUDES

- A. Starting of Systems:
 - 1. New systems in this Contract.
 - 2. Existing systems relocated or disturbed by the Work of this Contract.
- B. Demonstration and instructions.
- C. Testing, adjusting, and balancing.

1.02 RELATED SECTIONS

- A. Section 01 4000 - Quality Control: Manufacturers field reports.

1.03 STARTING SYSTEMS

- A. Coordinate schedule for start-up of various equipment and systems.
- B. Notify Architect seven days prior to start-up of each item.
- C. Verify that each piece of equipment or system has been checked for proper lubrication, drive rotation, belt tension, control sequence, and for conditions which may cause damage.
- D. Verify tests, meter readings, and specified electrical characteristics agree with those required by the equipment or system manufacturer.
- E. Verify that wiring and support components for equipment are complete and tested.
- F. Execute start-up under supervision of applicable Contractors' personnel in accordance with manufacturers' instructions.
- G. Submit a written report in accordance with Section 01 3300 - Submittals that equipment or system has been properly installed and is functioning correctly.

1.04 DEMONSTRATION AND INSTRUCTIONS

- A. Demonstrate operation and maintenance of Products to Owner's personnel two weeks prior to date of Substantial Completion, including existing telephone, intercom and fire alarm.
- B. Demonstrate Project equipment by a qualified manufacturers' representative who is knowledgeable about the Project.

- C. For equipment or systems requiring seasonal operation, perform demonstration for other season within four months.
- D. Utilize operation and maintenance manuals as basis for instruction. Review contents of manual with Owners' personnel in detail to explain all aspects of operation and maintenance.
- E. Demonstrate start-up, operation, control, adjustment, trouble-shooting, servicing, maintenance, and shutdown of each item of equipment at agreed time, at designated location.

PART 2 PRODUCTS

Not Used.

PART 3 EXECUTION

Not Used.

END OF SECTION

SECTION 01 7513

EXECUTION REQUIREMENTS

PART 1 GENERAL

1.01 SECTION INCLUDES

- A. Execution and installation requirements.
- B. Products and installation for patching and extending work.
- C. Transition and adjustments.
- D. Repair of damaged surfaces, finishes, and cleaning.
- E. Existing Systems: Relocation and restoration of function, testing.

1.02 RELATED SECTIONS

- A. Section 01 3300 - Submittals: Submittals procedures.
- B. Section 01 4000 - Quality Requirements: Testing and inspection procedures.
- C. Section 01 5000 - Temporary Facilities and Section 015600 - Temporary Controls: Exterior enclosures, temporary heating/cooling/ventilating facilities.

1.03 SUBMITTALS

- A. Survey work: Submit name, address, and telephone number of Surveyor before starting survey work.
 - 1. On request, submit documentation verifying accuracy of survey work.
 - 2. Submit a copy of site drawing signed by the Land Surveyor, that the elevations and locations of the work are in conformance with Contract Documents.
 - 3. Submit surveys and survey logs as for the project record.
- B. Cutting and Patching: Submit written request in advance of cutting or alteration which affects:
 - 1. Structural integrity of any element of Project.
 - 2. Integrity of weather exposed or moisture resistant element.
 - 3. Efficiency, maintenance, or safety of any operational element.
 - 4. Visual qualities of sight exposed elements.
 - 5. Work of Owner or separate Contractor.

1.04 QUALIFICATIONS

- A. For survey work employ a land surveyor registered in California and acceptable to Architect. Submit evidence of Surveyor's Errors and Omissions insurance coverage in the form of an Insurance Certificate.

1.05 PROJECT CONDITIONS

- A. Grade site to drain. Maintain excavations free of water. Provide, operate, and maintain pumping equipment.
- B. Protect site from puddling or running water. Provide water barriers as required to protect site from soil erosion.
- C. Ventilate enclosed areas to assist cure of materials, to dissipate humidity, and to prevent accumulation of dust, fumes, vapors, or gases.
- D. Dust Control: Execute work by methods to minimize raising dust from construction operations. Provide positive means to prevent air-borne dust from dispersing into atmosphere.
- E. Erosion and Sediment Control: Plan and execute construction by methods to control surface drainage from cuts and fills, from borrow and waste disposal areas. Prevent erosion and sedimentation.
- F. Noise Control: Provide methods, means, and facilities to minimize noise from demolition, earthwork and noise produced by construction operations.
- G. Pest Control: Provide methods, means, and facilities to prevent pests and insects from damaging the work.
- H. Rodent Control: Provide methods, means, and facilities to prevent rodents from accessing or invading premises.
- I. Pollution Control: Provide methods, means, and facilities to prevent contamination of soil, water, and atmosphere from discharge of noxious, toxic substances, and pollutants produced by construction operations.

1.06 COORDINATION

- A. Coordinate work of alterations and renovations to expedite completion sequentially and to accommodate occupancy requirements.
- B. Coordinate scheduling, submittals, and work of the various sections of the Project Manual to ensure efficient and orderly sequence of installation of interdependent construction elements, with provisions for accommodating items installed later.
- C. Verify utility requirements and characteristics of operating equipment are compatible with building utilities. Coordinate work of various sections having interdependent responsibilities for installing, connecting to, and placing in service, such equipment.
- D. Coordinate space requirements, supports, and installation of mechanical and electrical work which are indicated diagrammatically on Drawings. Follow routing shown for pipes, ducts, and conduit, as closely as practicable; place runs parallel with lines of building. Utilize spaces efficiently to maximize accessibility for other installations, for maintenance, and for repairs.

- E. In finished areas except as otherwise indicated, conceal pipes, ducts, and wiring within the construction. Coordinate locations of fixtures and outlets with finish elements.
- F. Coordinate completion and clean-up of work of separate sections.
- G. After Owner occupancy of premises, coordinate access to site for correction of defective work and work not in accordance with Contract Documents, to minimize disruption of Owner's activities.

PART 2 PRODUCTS

2.01 PATCHING MATERIALS

- A. New Materials: As specified in product sections; match existing products and work for patching and extending work.
- B. Type and Quality of Existing Products: Determine by inspecting and testing products where necessary, referring to existing work as a standard.
- C. Product Substitution: For any proposed change in materials, submit request for substitution described in Section 01 6000.

2.02 FABRICATION

- A. Machine-roll components or elements required to be curved or radiused. Do not field bend or "walk-down". Provide true curves minimizing joints, segmented fabrication not allowed.

PART 3 EXECUTION

3.01 EXAMINATION

- A. Verify that existing site conditions and substrate surfaces are acceptable for subsequent work. Beginning new work means acceptance of existing conditions.
- B. Verify that demolition is complete in alterations areas and areas are ready for installation of new work.
- C. Verify that existing substrate is capable of structural support or attachment of new work being applied or attached.
- D. Examine and verify specific conditions described in individual specification sections.
- E. Verify that utility services are available, of the correct characteristics, and in the correct locations.
- F. Prior to Cutting: Examine existing conditions prior to commencing work, including elements subject to damage or movement during cutting and patching. After uncovering existing work, assess conditions affecting performance of work. Beginning of cutting or patching means acceptance of existing conditions.

3.02 PREPARATION

- A. Cut, move, or remove items as necessary for access to alterations and renovation work. Replace and restore at completion.
- B. Remove unsuitable material not marked for salvage, such as rotted wood, corroded metals, and deteriorated masonry and concrete. Replace materials as specified for finished work.
- C. Remove debris and abandoned items from area and from concealed spaces.
- D. Close openings in exterior surfaces to protect existing work and salvage items from weather and extremes of temperature and humidity. Insulate ducts and piping to prevent condensation in exposed areas.
- E. Prepare surfaces and remove surface finishes to provide for proper installation of new work and finishes.
- F. Clean substrate surfaces prior to applying next material or substance.
- G. Seal cracks or openings of substrate prior to applying next material or substance.
- H. Apply manufacturer required or recommended substrate primer, sealer, or conditioner prior to applying any new material or substance in contact or bond.

3.03 LAYING OUT THE WORK

- A. Verify locations of survey control points prior to starting work.
- B. Promptly notify Architect of any discrepancies discovered.
- C. Contractor shall locate and protect survey control and reference points.
- D. Control datum for survey is that indicated on Drawings.
- E. Protect survey control points prior to starting site work; preserve permanent reference points during construction.
- F. Promptly report to Architect the loss or destruction of any reference point or relocation required because of changes in grades or other reasons.
- G. Replace dislocated survey control points based on original survey control. Make no changes without prior written notice to Architect.
- H. Utilize recognized engineering survey practices.
- I. Establish elevations, lines and levels. Locate and lay out by instrumentation and similar appropriate means:
 - 1. Site improvements including pavements; stakes for grading, fill and topsoil placement; utility locations, slopes, and invert elevations.
 - 2. Grid or axis for structures.

3. Building foundation, column locations, ground floor elevations.
 4. All other work as indicated or necessary.
- J. Periodically verify layouts by same means.
- K. Maintain a complete and accurate log of control and survey work as it progresses.

3.04 GENERAL INSTALLATION REQUIREMENTS

- A. Install Products as specified in individual sections.
- B. Make neat transitions. Patch work to match adjacent work in texture and appearance. Where new Work abuts or aligns with existing, perform a smooth and even transition.
- C. When existing finished surfaces are cut so that a smooth transition with new work is not possible, terminate existing surface along a straight line at a natural line of division and make recommendation to Architect.
- D. Grind or bush split-faced or textured masonry to achieve hairline fit to adjacent trim, flashings, inserts, escutcheons or other penetrating elements.
- E. Where removal of partitions or walls results in adjacent spaces becoming one, rework floors, walls, and ceilings to a smooth plane without breaks, steps, or bulkheads.
- F. Where a change of plane of 1/4 inch or more occurs in existing work, submit recommendation for providing a smooth transition for Architect review and request instructions.
- G. Trim existing doors as necessary to clear new floor finish. Refinish trim as required.
- H. Refinish visible existing surfaces to remain in renovated rooms and spaces, to specified condition for each material, with a neat transition to adjacent finishes.
- I. Re-cover and refinish work that exposes mechanical and electrical work exposed accidentally during the work.

3.05 CUTTING AND PATCHING

- A. Execute cutting and patching including excavation and fill to complete the work, to uncover work to install improperly sequenced work, to remove and replace defective or non-conforming work, to remove samples of installed work for testing when requested, to provide openings in the work for penetration of mechanical and electrical work, to execute patching to complement adjacent work, and to fit Products together to integrate with other work.
- B. Execute work by methods to avoid damage to other work, and which will provide appropriate surfaces to receive patching and finishing. In existing work, minimize damage and restore to original condition.
- C. Employ original installer to perform cutting for weather exposed and moisture resistant elements, and sight exposed surfaces.

- D. Cut rigid materials using masonry saw or core drill. Pneumatic tools not allowed without prior approval.
- E. Restore work with new Products in accordance with requirements of Contract Documents.
- F. Fit work air tight to pipes, sleeves, ducts, conduit, and other penetrations through surfaces.
- G. At penetrations of fire rated walls, partitions, ceiling, or floor construction, completely seal voids with fire rated material in accordance with Section 07840, to full thickness of the penetrated element.
- H. Refinish surfaces to match adjacent finish. For continuous surfaces, refinish to nearest intersection or natural break. For an assembly, refinish entire unit.
- I. Patch or replace portions of existing surfaces which are damaged, lifted, discolored, or showing other imperfections. Repair substrate prior to patching finish. Finish patches to produce uniform finish and texture over entire area. When finish cannot be matched, refinish entire surface to nearest intersections.

3.06 PROGRESS CLEANING

- A. Maintain areas free of waste materials, debris, and rubbish. Maintain site in a clean and orderly condition.
- B. Remove debris and rubbish from pipe chases, plenums, attics, crawl spaces, and other closed or remote spaces, prior to enclosing the space.
- C. Broom and vacuum clean interior areas prior to start of surface finishing, and continue cleaning to eliminate dust.
- D. Collect and remove waste materials, debris, and rubbish from site periodically and dispose off-site.

3.07 PROTECTION OF INSTALLED WORK

- A. Protect installed work and provide special protection where specified in individual specification sections.
- B. Provide temporary and removable protection for installed Products. Control activity in immediate work area to prevent damage.
- C. Provide protective coverings at walls, projections, jambs, sills, and soffits of openings.
- D. Protect finished floors, stairs, and other surfaces from traffic, dirt, wear, damage, or movement of heavy objects, by protecting with durable sheet materials.
- E. Prohibit traffic or storage upon waterproofed or roofed surfaces. If traffic or activity is necessary, obtain recommendations for protection from waterproofing or roofing material manufacturer.
- F. Prohibit traffic from landscaped areas.

3.08 ADJUSTING

- A. Adjust operating Products and equipment to ensure smooth and unhindered operation.
- B. Testing, adjusting, and balancing HVAC systems: See Division 23 and Sections 01 4000 and 01 7500.

3.09 EXISTING SYSTEMS

- A. Examine and test existing building systems and utilities with components requiring relocation during performance of this work. Examples may include but are not limited to:
 - 1. Mechanical Systems
 - 2. Plumbing Systems
 - 3. Electrical Systems, line voltage, low voltage, signal alarm, or data.
 - 4. Fiber-optic data or communication cabling systems.
- B. Remove or relocate these components while work is performed.
 - 1. Fiber-optic data cabling systems are extremely fragile and subject to mechanical damage. Relocate these systems with great care. Do not disconnect or remove these systems, which must remain in place and in operation during the Work.
- C. Restore these components to the former location upon completion of the Work.
- D. Test systems under provisions of Section 01 7500 to confirm proper operation. Conduct tests in the presence of the Architect and Owner's Representative.
- E. Perform remedial work as necessary to establish proper operation. Assume responsibility for proper operation of systems following completion of Work.

END OF SECTION

SECTION 01 8113

SUSTAINABLE DESIGN REQUIREMENTS

PART 1 GENERAL

1.01 SUMMARY

- A. Section includes general requirements and procedures for compliance with California Code of Regulations, Title 24, Part 11 California Green Building Standards Code, "CAL-Green".
 - 1. Chapter 5- Non-Residential Mandatory Measures.

1.02 RELATED REQUIREMENTS

- A. Pertinent sections specifying erosion control.
- B. Section 01 6116 - Volatile Organic Compound (VOC) Restrictions.
- C. Section 01 7419 - Construction Waste Management and Disposal.
- E. Pertinent sections specifying landscape irrigation.

1.03 DEFINITIONS

- A. CAL-Green Definitions: Certain terms are defined by CAL-Green in Chapter 5 of the Code. Words and terms used in this section shall have the meanings shown therein.

1.04 INFORMATIONAL SUBMITTALS

- A. General: Submit CAL-GREEN submittals required by code and in other Specification Sections.
- B. CAL-GREEN submittals are in addition to other submittals. If submitted item is identical to that submitted to comply with other requirements, submit duplicate copies as a separate submittal to verify compliance with indicated CAL-GREEN requirements.
- C. Acceptable verification submittals are specified in the related sections.

PART 2 PRODUCTS

2.01 REQUIREMENTS - GENERAL

- A. Provide products and procedures necessary to confirm CAL-GREEN compliance required in this Section. Although other Sections may specify some CAL-GREEN requirements, the Contractor shall determine additional materials, techniques, means, methods and procedures necessary to comply with CAL-GREEN requirements.

2.02 STORM WATER POLLUTION PREVENTION PLAN

- A. Section 5.106.1: Comply with requirements of this code section, local ordinances, General Conditions, Special Provisions, and related sections specifying erosion control.

2.03 OUTDOOR WATER USE

- A. Section 5.304.3.1: Irrigation Controllers: Comply with requirements of this code section, local ordinances and Section 32 8000.

2.04 CONSTRUCTION WASTE REDUCTION

- A. Section 5.408 Construction Waste Management, Diversion and Recycling: Comply with requirements of this code section, local ordinances and Section 01 7419.

2.05 BUILDING MAINTENANCE AND OPERATION

- A. Section 5.410.2.3, 4. Commissioning and Functional Performance Testing: Participate in Commissioning and provide functional performance testing as required by these code sections and as specified in Section 01 7500.
- B. Section 5.410.2.5. Documentation and Training: Provide Operations Training as required by these code sections and as specified in Section 01 7500 and Systems Manual as specified in Section 01 7500.

2.06 POLLUTANT CONTROL

- A. Section 5.504.3 Indoor Air Quality: Comply with requirements of this code section, local ordinances.
 - 1. During storage, rough installation and until final start-up of HVAC equipment, securely cover all ducts and air distribution component openings with plastic, tape, sheet metal or other methods acceptable to enforcing agency to reduce dust or debris collected in the system.
- B. Section 5.504.4 Finish Material Pollutant Control: All Finish materials shall comply with requirements of this code section, local ordinances and Section 01 6116.

PART 3 EXECUTION

3.01 GENERAL

- A. Comply with Section 01 7419 - Construction Waste Management and Disposal.
- B. Comply with execution requirements of related sections and applicable local codes and ordinances.

END OF SECTION

**SECTION 02 4116
BUILDING DEMOLITION**

PART 1 GENERAL

1.01 SECTION INCLUDES

- A. Demolition of designated structures and removal of materials from site.
- B. Demolition and removal of foundations and slabs on grade.
- C. Demolition and removal of site paving.
- D. Disconnecting and removal of identified utilities.

1.02 RELATED SECTIONS

- A. Section 01 5000 - Temporary Facilities and Controls: Barriers, Fences and Landscape Protection.
- B. Section 01 6000 - Product Requirements.
- C. Section 01 7513 - Execution Requirements: Re-installation of removed components.
- D. Section 01 7419 - Construction Waste Management.
- E. Divisions 31 & 32: Pertinent sections specifying clearing outside periphery of structures and backfilling below-grade areas where demolition items are removed.

1.03 SUBMITTALS

- A. See Section 01 3300 - Submittals, for submittal procedures.
- B. Project Record Documents: Accurately record actual locations of capped utilities.

1.04 QUALITY ASSURANCE

- A. Demolition Firm: Company specializing in type of work required by this section, with minimum five (5) years of documented experience.

1.05 REGULATORY REQUIREMENTS

- A. Conform to applicable code for demolition of structures, safety of adjacent structures, dust control.
- B. Obtain required permits from authorities.
- C. Notify affected utility companies before starting work and comply with their requirements.
- D. Do not close or obstruct roadways without permits.
- E. Conform to applicable regulatory procedures when hazardous or contaminated materials are discovered.

PART 2 PRODUCTS

2.01 MATERIALS

- A. Fill Material: As specified in Section 31 2323 - Fill and Backfill.

PART 3 EXECUTION

3.01 PREPARATION

- A. Provide, erect, and maintain temporary barriers and security devices at locations indicated.
- B. Protect existing landscaping materials, appurtenances, and structures that are not to be demolished.

- C. Prevent movement or settlement of adjacent structures. Provide bracing and shoring.
- D. Mark location of utilities.

3.02 DEMOLITION REQUIREMENTS

- A. Conduct demolition to minimize interference with adjacent structures.
- B. Cease operations immediately if adjacent structures appear to be in danger. Notify Owner; do not resume operations until directed.
- C. Conduct operations with minimum interference to public or private accesses. Maintain protected egress and access at all times.
- D. Obtain written permission from adjacent property owners when demolition equipment will traverse, infringe upon or limit access to their property.
- E. Sprinkle demolition areas with water to minimize dust. Provide hoses and water connections for this purpose.

3.03 DEMOLITION

- A. Disconnect and cap designated utilities within demolition areas. Remove disconnected utilities.
- B. Remove foundation walls and footings to a minimum of two feet below finished grade beyond area of new construction.
- C. Remove concrete slabs on grade.
- D. Break up site paving in areas indicated.
- E. Remove materials to be retained or re-installed in a manner that will prevent damage. Store and protect in accordance with requirements of Section 01 6000.
- F. Backfill areas excavated caused as a result of demolition, in accordance with Section 31 2323.
- G. Rough grade and compact areas affected by demolition to maintain site grades and contours.
- H. Remove demolished materials from site per the Construction Waste Management program.
- I. Do not burn or bury materials on site. Leave site in clean condition.
- J. Remove temporary work.

3.04 SCHEDULES

- A. Relics, antiques, and similar objects remain the property of Owner. Obtain direction regarding method of removal.

END OF SECTION

SECTION 03 1000

CONCRETE FORMING AND ACCESSORIES

PART 1 - GENERAL

1.01 SUMMARY

- A. Section Includes: All labor, materials and equipment and all operations required to complete all formwork as indicated on the drawings; to produce shapes and configurations as shown, as required; and as specified herein, including:
 - 1. Forms, shores, bracing, removal and other operations as necessary for all cast-in-place concrete and masonry placed.
 - 2. Setting and securing anchor bolts and other metal items embedded in concrete into formwork, using materials and layouts furnished and delivered to jobsite as specified under other sections.
- B. Related Sections:
 - 1. Pertinent Sections of Division 03 specifying concrete construction.
 - 2. Pertinent Sections of other Divisions specifying work to be embedded in concrete or work penetrating concrete foundations and formwork.

1.02 REFERENCES

- A. California Code of Regulations, Title 24, latest adopted edition (herein noted as CBC): Chapter 19A Concrete.
- B. American Concrete Institute (ACI) 347 "Recommended Practice for Concrete Formwork".
- C. American Plywood Association (APA) "Concrete Forming Guide".
- D. West Coast Lumberman Inspection Bureau (WCLIB) "Standard Grading Rules for West Coast Lumber".
- E. ACI SP-066 "ACI Detailing Manual".
- F. ACI 301 "Specifications for Structural Concrete".
- G. Concrete Reinforcing Steel Institute (CRSI) "Manual of Standard Practice".

1.03 DESIGN REQUIREMENTS

- A. Design, engineer, and construct formwork, shoring and bracing to conform to design and code requirements, resist imposed loads; resultant concrete to conform to required shape, line and dimension.

1.04 SUBMITTALS

- A. Limitation of review: Structural Engineer's review will be required only where specifically requested for general architectural applications and features only. Contractor is responsible for structural stability, load-resisting characteristics and sufficiency of form work design.

1.05 QUALITY ASSURANCE

- A. General: All form materials shall be new at start of work. Produce high quality concrete construction. Minimize defects due to joints, deflection of forms, roughness of forms, nonconforming materials, concrete or workmanship.
- B. Reuse of Forms: Plywood forms may be reused, if thoroughly cleaned of all dirt, mortar, and foreign materials, and undamaged at edges and contact face. Reuse shall be subject to permission from the Architect without exception, and issued in writing. Reuse of any panel which will produce a blemish on exposed concrete, will not be permitted.

PART 2 - PRODUCTS

2.01 MATERIALS

- A. Form Materials:
 - 1. Non-Exposed Surface Formwork Facing: Forms for concrete which is not exposed to view, may be of plywood as specified for exposed surfaces, or square edge 1x nominal Douglas Fir, Construction Grade, S4S.
 - 2. Exposed Surface Formwork Facing:
 - a. Forms for all exterior and interior concrete flat surfaces unless otherwise specified as board formed shall be new Douglas Fir Plywood (APA) ply, 5/8-inch, B-B Plyform, Class 1, Exterior Type, oiled and edged and edge-sealed conforming to U.S. Product Standard PS 1 in large sheet sizes to achieve joint patterns shown.
 - b. All exposed concrete edges shall be chamfered 3/4" minimum or as noted on the drawings.
 - 3. Exposed Surface Formwork - Special Pattern Form Liner:
 - a. Forms for all exterior and interior concrete flat surfaces indicated shall be as designated by Architect.
- B. Earth Forms: Allowed, subject to soil standing in excavations without ravel or caving.
- C. Form Release Agent: Spray-on compound, not affecting color, bond or subsequent treatment of concrete surfaces. Maximum VOC content shall comply with local requirements and California Green Building Code.
- D. Accessories: Types recommended by manufacturers or referenced standards to suit conditions indicated;
 - 1. Anchors, spacers, void in-fill materials: sized to resist imposed loads.
 - 2. Form Ties: Prefabricated rod, flat band, or wire snap ties with 1" break-back or threaded internal disconnecting type with external holding devices of adequate bearing area. Ties shall permit tightening and spreading of forms and leave no metal closer than 1" to surface.
- E. Corner Chamfers and Rustications: Filleted, wood strip or foam type; sizes and shapes as detailed, or 3/4 x 3/4 inch size minimum if not detailed; maximum possible lengths.

- F. Nails, Spikes, Lag Bolts, Through Bolts, Anchorages: Sized as required, of sufficient strength and character to maintain formwork in place while placing concrete.

PART 3 - EXECUTION

3.01 EXAMINATION

- A. Inspect the substrate and the conditions under which concrete formwork is to be performed. Correct conditions detrimental to timely and proper completion of the work. Do not proceed with the work until unsatisfactory conditions have been corrected. Commencement of work indicates acceptance of substrates and conditions.
- B. Verify lines, levels and centers before proceeding with formwork. Ensure that dimensions agree with drawings.

3.02 EARTH FORMS

- A. If natural soil or compacted fill can be accurately cut and maintained, foundations and grade beams may be poured against earth without forming. Provide positive protection of trench top corners.
- B. Maintain earth forms free of water and foreign materials.

3.03 ERECTION - FORMWORK

- A. General: Construct formwork in accordance with calculations, and recommendations of Section 401 of ACI 347. Construct forms to the sizes, shapes, lines and dimensions shown, and as required to obtain accurate alignment, location, grades, level and plumb work in finished structure. Provide for openings, offsets, sinkages, keyways, recesses, moldings, rustications, reglets, chamfers, blocking, screeds, bulkheads, anchorages and inserts, and other features required. Use selected materials to obtain required finishes.
 - 1. Construct cambers specified in concrete members and slabs in the formwork.
 - 2. Schedule the work and notify other trades in ample time so that provisions for their work in the formwork can be made without delaying progress of the project. Install all sleeves, pipes, etc. for building services systems, or other work. Secure information about and provide for all openings, offsets, recessed nailing blocks, channel chases, anchors, ties, inserts, etc. in the formwork before concrete placement.
 - 3. Deflection: Formwork and concrete with excessive deflection after concrete placement will be rejected. Excessive deflection is that which will produce visible and noticeable waves in the finished concrete.
 - 4. Measure formwork for elevated structural slabs, columns, wall elevations points of maximum camber and submit in writing to the Architect/Engineer prior to placing concrete.
- B. Formwork Construction: Erect formwork, shoring and bracing to achieve design requirements, in accordance with requirements of ACI 301. Uniform, substantial and sufficiently tight to prevent leakage of concrete paste, readily removable without impact, shock or damage to cast-in-place concrete surfaces and adjacent materials. Tie, brace, shore, and support to insure stability against pressures from any source, without failure of any component part and without

excessive deflection. Solidly butt joints and provide backup material at joints as required to prevent leakage and fins.

- C. Provide all openings, offsets, inserts, anchorages, blocking, and other features of the work as shown or required. See INSERTS, EMBEDDED PARTS, AND OPENINGS for detailed requirements.
- D. Warped, checked, or scuffed forms will be rejected.
- E. Maintain membranes, reinforcing and other work free of damage; protect with plywood runway boards or other positive, durable means.
- F. Align joints and make watertight. Keep form joints to a minimum.
- G. Provide fillet and chamfer strips on external corners of exposed locations and as indicated to form patterns in finished work. Extend patterns around corners and into alcoves, on backs of columns and similar locations not otherwise shown.
 - 1. Produce beveled, smooth, solid, unbroken lines, except as otherwise indicated to conform to patterns.
 - 2. Form corners and chamfers with 3/4 inch x 3/4 inch strips, unless otherwise indicated, accurately formed and surfaced to produce uniformly straight lines and tight edge joints. Extend terminal edges to required limit and miter chamfer at changes in direction.
- H. Unexposed corners may be formed either square or chamfered.
- I. Ties and Spreaders: Arrange in a pattern acceptable to the Architect when exposed. Snap-ties may be used except at joints between pours where threaded internal disconnecting type shall be used.
- J. Coordinate this section with other sections of work that require attachment of components to formwork.
- K. Reglets and Rebates: Accurately locate, size, and form all reglets and rebates required to receive work of other trades, including flashing, frames, and equipment.

3.04 APPLICATION - FORM RELEASE AGENT

- A. Apply form release agent on formwork in accordance with manufacturer's recommendations.
- B. Apply prior to placement of reinforcing steel, anchoring devices, and embedded items.
- C. Do not allow excess form coating material to accumulate in the forms or to come into contact with reinforcement or surfaces which will be bonded to fresh concrete.
- D. Coat steel forms with a non-staining, rust-preventative form oil or otherwise protect against rusting. Rust-stained steel formwork will be rejected.
- E. Leave no residue or stain on the face of the concrete, nor affect bonding of subsequent finishes or work specified in other sections.

3.05 INSERTS, EMBEDDED PARTS, AND OPENINGS

- A. Provide formed openings where required for items to be embedded in passing through concrete work.
 - 1. Provide openings in concrete formwork to accommodate work of other sections including those under separate contracts (if any). Size and location of openings, recesses and chases shall be in accordance with the section requiring such items. Accurately place and securely support items to be built into forms.
- B. Construction Joints: Construct and locate generally as indicated on Drawings and only at locations approved by Structural Engineer, so as not to impair the strength of the structure. Form keys in all cold joints shown or required.
- C. Locate and set in place items that will be cast directly into concrete.
- D. Rough Hardware and Miscellaneous Metal: Set inserts, sleeves, bolts, anchors, angles, and other items to be embedded in concrete. Set embedded bolts and sleeves for equipment to template and approved shop drawings prepared by trades supplying equipment.
- E. Coordinate with work of other sections in forming and placing openings, slots, reglets, recesses, sleeves, bolts, anchors, other inserts, and components of other work.
- F. Wood Inserts and Nailers: Provide approved preservative-treated lumber. Set all required nailing blocks, grounds, and other inserts as required to produce results shown. Wood plugs shall not be used.
- G. Install accessories in accordance with manufacturer's instructions, so they are straight, level, and plumb. Ensure items are not disturbed during concrete placement.
- H. Piping: Do not embed piping in structural concrete unless locations specifically approved by Structural Engineer.
- I. Conduit: Place conduit below slabs-on-grade and only as specifically detailed on structural drawings. Minimum clear distance between conduits shall be 3 diameters. Location shall be subject to Engineer's written approval and shall not impair the strength of the structure.
- J. Provide temporary ports or openings in formwork where required to facilitate cleaning and inspection. Locate openings at bottom of forms to allow flushing water to drain.
 - 1. Provide openings for the introduction of vibrators at intervals necessary for proper placement.
 - 2. Close temporary openings with tight fitting panels, flush with inside face of forms, and neatly fitted so joints will not be apparent in exposed concrete surfaces.
- K. Install Form Liner inserts in accordance with manufacturer's recommendations, to produce patterns and textures indicated.
- L. Install waterstops in accordance with manufacturer's recommendations to provide continuous waterproof barrier.

3.06 FORM CLEANING

- A. Clean forms as erection proceeds, remove foreign matter within forms.
- B. Clean formed cavities of debris prior to placing concrete.
 - 1. Remove all dirt, chips, sawdust, rubbish, water and foreign materials detrimental to concrete.
 - 2. Flush with water or use compressed air to remove remaining foreign matter. Ensure that water and debris drain to exterior through clean-out ports.

3.07 FOOTINGS

- A. Verify elevations and provide final excavation required for footings prior to placing of concrete.

3.08 EQUIPMENT BASES

- A. Form concrete bases for all mechanical and electrical equipment in accordance with approved shop details furnished by other sections.
- B. Sizes and locations as indicated and as required to produce results shown.
- C. Provide covered base for all equipment bases placed on concrete slabs.

3.09 FORMWORK TOLERANCES

- A. Construct formwork to maintain tolerances required by ACI 301.

3.10 FIELD QUALITY CONTROL

- A. Inspect erected formwork, shoring, and bracing to ensure that work is in accordance with formwork design, and to verify that supports, fastenings, wedges, ties, and items are secure.
- B. Do not reuse wood formwork more than 2 times for concrete surfaces to be exposed to view. Do not patch formwork.
- C. Clean and repair surfaces to be re-used in the work. Split, frayed, delaminated or otherwise damaged form facing material will not be acceptable. Apply new form coating compound material to concrete contact surfaces as specified for new formwork.
- D. When forms are extended for successive concrete placement, thoroughly clean surfaces, remove fins and laitance, and tighten forms to close all joints. Align and secure joints to avoid offsets.

3.11 FORM REMOVAL

- A. Do not loosen or remove forms before minimum curing period has elapsed without employment of appropriate alternate curing methods, approved by the Architect in writing.
- B. Remove forms without damage to the concrete using means to insure complete safety of the structure and without damage to exposed beams, columns, wall edges, chamfers and inserts. Loosen forms carefully. Do not wedge pry bars, hammers, or tools against finish concrete surfaces scheduled for exposure to view.

- C. Do not remove forms until the concrete has hardened sufficiently to permit safe removal and the concrete has attained sufficient strength to safely support imposed loads. The minimum elapsed time for removal of forms after concrete has been placed shall be as follows:
 - 1. Columns and Walls: 7 days, provided members are not subjected to overhead loads.
 - 2. Retaining Walls: 21 days minimum.
 - 3. Footings: 7 days minimum. If backfilled immediately, side forms may be removed 24 hours after concrete is placed.
 - 4. Beams, elevated slab, and similar overhead conditions: 28 days unless adequate shoring is provided.
- D. Durations listed above are minimums and are subject to extension at the sole judgment of the Architect/Engineer.
- E. Reshoring: Reshore members where and if required by Formwork Design Engineer.
- F. Do not subject concrete to superimposed loads (structure or construction) until it has attained full specified design strength, nor for a period of at least 14 days after placing.
- G. Store removed forms to prevent damage to form materials or to fresh concrete. Discard damaged forms.

3.12 CLEANING

- A. Remove excess material and debris associated with this work from the job site.

END OF SECTION

SECTION 03 2000
CONCRETE REINFORCING

PART 1 GENERAL

1.01 SUMMARY

A. Section Includes:

1. Reinforcing steel work for all concrete and masonry work as indicated on the drawings and specified herein.
2. Coordinate this work with other work affected by these operations, such as forms, electrical work, mechanical work, structural steel, masonry and concrete.

B. Related Sections:

1. Pertinent Sections of Division 01 specifying Quality Control and Testing Laboratory services.
2. Pertinent Sections of Divisions 03 specifying concrete construction.
3. Pertinent Sections of Divisions 04 specifying masonry construction.
4. Pertinent Sections of other Divisions specifying work to be embedded in concrete or work penetrating concrete work.

1.02 REFERENCE STANDARDS

- A. California Code of Regulations, Title 24, latest adopted edition (herein noted as CBC) Chapter 19A Concrete.
- B. American Concrete Institute (ACI) 301 "Specifications for Structural Concrete for Buildings".
- C. ACI 318 "Building Code Requirements for Reinforced Concrete and Commentary".
- D. ACI SP-066 "ACI Detailing Manual".
- E. American Society for Testing and Materials (ASTM) A185 "Standard Specification for Steel Welded Wire Reinforcement, Plain, for Concrete".
- F. ASTM A615 "Standard Specification for Deformed and Plain Carbon-Steel Bars for Concrete Reinforcement".
- G. ASTM A706 "Standard Specification for Deformed and Plain Low-Alloy Steel Bars for Concrete Reinforcement".
- H. American Welding Society (AWS) D1.4 - "Structural Welding Code for Reinforcing Steel".
- I. Concrete Reinforcing Steel Institute (CRSI) "Manual of Standard Practice".

1.03 SUBMITTALS

- A. Submit in accordance with pertinent sections of Division 01 specifying submittal procedures. Submit for review prior to fabrication.
- B. Limitation of Review: Structural Engineer's review will be for general conformance with design intent as indicated in the Contract Documents and does not relieve Contractor of full responsibility for conformance with the Contract Documents. The General Contractor shall review and approve shop drawings prior to submittal to the Architect/Engineer.
- C. Shop Drawings: Show complete fabrication and placing details of all reinforcing steel. Comply with requirements of ACI SP-66. Include:
 - 1. Bar sizes and schedules;
 - 2. Shapes of bent bars, layout and spacing of bars, location of splices.
 - 3. Stirrup spacing, arrangements and assemblies,
 - 4. References to Contract Document detail numbers and designations.
 - 5. Wall elevations corresponding to elevations shown in Contract Documents.
- D. Product Data: Submit manufacturer's product data, specifications, location and installation instructions for proprietary materials and reinforcement accessories. Provide samples of these items upon request.
- E. Certificates: Submit all certifications of physical and chemical properties of steel for each heat number as manufactured, including location of material in structure as specified below in Article titled QUALITY ASSURANCE. All materials supplied shall be tagged with heat numbers matching submitted Mill Test Report analyses.
- F. Samples: Provide to the Owner's Testing laboratory as specified in Article SOURCE QUALITY CONTROL.

1.04 QUALITY ASSURANCE

- A. Perform work of this Section in accordance with CRSI DA4, CRSI P1, ACI 301, and ACI 318.
- B. Requirements of Regulatory Agencies, refer to pertinent Sections of Division 01 and CBC.
- C. Certification and Identification of Materials and Uses: Provide Owner's Testing Agency with access to fabrication plant to facilitate inspection of reinforcement. Provide notification of commencement and duration of shop fabrication in sufficient time to allow inspection and all material identification/test information listed below.
 - 1. Provide manufacturer's Mill Test Reports for all materials. Include chemical and physical properties of the material for each heat number manufactured. Tag all fabricated materials with heat number.
 - 2. Provide letter certifying all materials supplied are from heat numbers covered by supplied mill certificates. Include in letter the physical location of each grade of reinforcing and/or heat number in the project (i.e. foundations, walls, etc.).
 - 3. Unidentified Material Tests: Where identification of materials by heat number to mill tests cannot be made, Owner's Testing Agency shall test unidentified materials as described below.

- D. Testing and Inspection: Tests and Inspections required by Independent Testing Agency are specified below in Articles SOURCE QUALITY CONTROL and FIELD QUALITY CONTROL. Duties and limitations of Independent Testing Agency, test costs and test reports in conformance with pertinent Sections of Division 01.

1.05 DELIVERY, STORAGE AND HANDLING

- A. Comply with pertinent requirements of Division 01.
- B. Deliver reinforcement to project site in bundles marked with durable tags indicating heat number, mill, bar size and length, proposed location in the structure and other information corresponding with markings shown on placement diagrams.
- C. Handle and store materials above ground to prevent damage, contamination or accumulation of dirt or rust.

PART 2 PRODUCTS

2.01 MATERIALS

- A. Reinforcing Steel: Deformed billet steel bars, ASTM A706 Grade 60 or ASTM A615 Grade 60.
1. Exception: Bars #3 and smaller shall be Grade 40 minimum, unless otherwise noted on the drawings.
 2. Welded reinforcement shall be ASTM A706, or A615 meeting carbon requirements of AWS D1.4. Welding shall conform with AWS D1.4.
 3. All reinforcement to be unfinished.
 4. ASTM A615 reinforcement at special structural concrete walls, concrete coupling beams, and special concrete moment frames shall have maximum yield stress of 78,000 psi and the tensile strength shall be greater than 125% of the actual yield strength. Test ASTM A615 reinforcement for conformance to these criteria prior to fabrication and/or installation.
- B. Welded Wire Reinforcement: ASTM A185.
- C. Tie Wire: No. 16 AWG or heavier, black annealed.
- D. Concrete Blocks: Slab-on-grade conditions only, as required to support reinforcing bars in position.
- E. Reinforcing Supports: Plastic or galvanized steel chairs, bolsters, bar supports, or spacers sized and shaped for adequate support of reinforcement and construction loads imposed during concrete placement, meeting ACI and CRSI standards.
1. For use over formwork: Galvanized wire bar type supports complying with CRSI recommendations. Provide plastic tips where exposed to view or weather after removal of formwork. Do not use wood, brick, or other unacceptable materials.
 2. For slabs on grade: Supports with sand plates or horizontal runners where base material will not support chair legs.

- F. Reinforcement Splice Couplers: For use only where specified on drawings. Submit other locations proposed for use to Engineer for review. "L-Series Bar Lock" Coupler Systems for Splicing Reinforcement Bars, ESR-2495, by Dayton-Superior Corporation.

2.02 FABRICATION

- A. Fabricate concrete reinforcing in accordance with CRSI (DA4), unless specifically shown otherwise. Details not specifically shown or indicated shall conform to SP-066 and specified codes and standards.
 - 1. Accurately shop-fabricate to shapes, bends, sizes, gauges and lengths indicated or otherwise required.
 - 2. Bend bars once only. Discard bars improperly bent due to fabricating or other errors and provide new material; do not re-bend or straighten unless specifically indicated. Rebending of reinforcement in the field is not allowed.
 - 3. Do not bend reinforcement in a manner that will injure or weaken the material or the embedding concrete.
 - 4. Do not heat reinforcement for bending. Heat-bent materials will be rejected.
- B. Unacceptable materials: Reinforcement with any of the following defects will not be permitted in the work.
 - 1. Bar lengths, depths and bends exceeding specified fabrication tolerances.
 - 2. Bends or kinks not indicated on Drawings or final shop drawings.
 - 3. Bars with reduced cross-section due to rusting or other cause.
- C. Tag reinforcement with durable identification to facilitate sorting and placing.

2.03 SOURCE QUALITY CONTROL

- A. The Testing Agency, as specified in the Article QUALITY ASSURANCE, will perform the following:
 - 1. Sampling and Tests of Reinforcing Bars per CBC 1910A.2.
 - 2. Material Testing:
 - a. Identified Steel: When samples are taken from bundled steel identified by heat number, matched with accompanying mill analyses as delivered from the mill, Owner's Testing Agency will perform one tensile test and one bend test per each ten tons or fraction thereof for each required size of reinforcing steel.
 - b. Unidentified Steel: When identification of materials by heat number matched to accompanying mill analyses cannot be made, perform one tensile test and one bend test per each two and one-half tons or fraction thereof for each required size of reinforcing steel. Tests of unidentified steel shall be performed by the Owner's Testing Agency and costs for these tests shall be paid by the Contractor by deductive change order.

PART 3 EXECUTION

3.01 EXAMINATION

- A. Inspect the conditions under which concrete reinforcement is to be placed. Do not proceed with the work until unsatisfactory conditions have been corrected.
- B. Coordinate with work of other sections to avoid conflicts or interference. Bring conflicts between reinforcement and other elements to Architect's attention. Resolve conflicts before concrete is placed.
- C. Notify Architect, Structural Engineer, and Authority Having Jurisdiction for review of steel placement not less than 48 hours before placing concrete.

3.02 PLACEMENT

- A. General: Comply with the specified codes and standards, and Concrete Reinforcing Steel Institute recommended practice for "Placing Reinforcing Bars", for details and methods of reinforcement placement and supports, and as herein specified.
- B. Clean bars free of substances which are detrimental to bonding. Maintain reinforcement clean until embedded in concrete.
- C. Place reinforcement to obtain the minimum coverages for concrete protection. Do not deviate from required position. Maintain required distance, spacing and clearance between bars, forms, and ground.
- D. Location and Support: Provide metal chairs, runners, bolsters, spacers and hangers, as required.
- E. Provide additional steel reinforcement as necessary or as directed, to act as spreaders or separators to maintain proper positioning.
- F. Tying and Attachment: Securely tie at all intersections and supports with wire. Prevent dislocation or movement during placement of concrete. Direct twisted ends of wire ties away from exposed concrete surfaces.
- G. Separate reinforcing from pipes or conduits with approved non-metallic separators. Do not use wood or steel form stakes or reinforcement used as stakes as support for reinforcement.
- H. Accommodate placement of formed openings required by other sections.
- I. Obstructions:
 - 1. Where obstructions, block-outs, or penetrations (conduits, raceways, ductwork) prevent continuous placement of reinforcement as indicated, provide additional reinforcing as detailed and as directed by the Structural Engineer to supplement the indicated reinforcement around the obstruction.
 - 2. Place additional trim bars, ties, stirrups, or other elements as detailed and as directed at all opening, sleeves, pipes or other penetrations through structural elements.
- J. Welded Wire Reinforcement: Reinforce slabs with 6"x 6"-W1.4 x W1.4 welded wire reinforcement reinforcing, unless otherwise noted on drawings.
 - 1. Provide flat sheets only, no rolls. Straighten, cut to required size, and lay out flat in place.

2. Securely wire-tie reinforcement to other reinforcement at frequent intervals.
3. Extend reinforcement over supporting beams and walls, and to within 1 inch of edge of slabs, construction joints, and expansion joints.
4. Support reinforcement in mid-depth of slab.
5. Lift reinforcement at intervals as slab concrete is placed, ensure proper embedment

3.03 REINFORCING SPACING AND COVERAGE

- A. Spacing: Do not space bars closer than four (4) diameters of the largest of two adjacent bars, except at bar laps, which shall be placed such that a minimum of 2 bar diameters is clear between bars.
- B. Where reinforcing in members is placed in two layers, the distance between layers shall not be less than four bar diameters of the largest bar and the bars in the upper layers shall be placed directly above those in the bottom layer, unless otherwise detailed or dimensioned.
- C. Coverage of bars (including stirrups and columns ties) shall be as follows, unless otherwise shown:
 1. Footings and Mat Foundation: 3 inches to any soil face, 2 inches to top.
 2. Slabs (on grade): 2 inches to grade face, 1-1/2 inches to top face.
 3. Slabs (elevated): 1-1/2 inches top and bottom.
 4. Beam & Column: 1-1/2 inches to form.
 5. Walls: 1-1/2 inches clear to form and 2 inches clear to form at soil face.

3.04 DOWELS, SPLICES, OFFSETS AND BENDS

- A. Provide standard reinforcement splices at splices, corners, and intersections by lapping ends, placing bars in contact, and tightly tying with wire at each end. Comply with details shown on structural drawings and requirements of ACI 318.
- B. Provide minimum 1-1/2 inch clearance between sets of splices. Stagger splices in horizontal bars so that adjacent splices will be 4 feet apart.
- C. Laps of welded wire reinforcement shall be at least two times the spacing of the members in the direction lapped but not less than twelve inches.
- D. Splices of reinforcement shall not be made at points of maximum stress. Provide splice lengths as noted on the structural drawings, with sufficient lap to transfer the stress between bars by bond and shear.
- E. Spacing:
 1. Space bars minimum distance specified and all lapped bars 2 bar diameters (minimum) clear of the next bar.
 2. Stagger splices of adjacent bars where possible and where required to maintain bar clearance.
 3. Beam or slab top bars shall be spliced mid-span of column support and bottom bars spliced at column supports.
 4. Request Architect/Engineer review prior to placement for all splices not shown on the drawings.

- F. Reinforcement Couplers: Install at all locations indicated and may be used as an alternate to lap splices in general. Install couplers in accordance with manufacturer's recommendations.

3.05 WELDING

- A. No reinforcing shall be welded unless specifically indicated or without prior approval of the Structural Engineer and the Authority Having Jurisdiction.
- B. Only when so approved for use as noted above, all welding shall conform to AWS D1.4, ACI 318 Section 26.6.4, and CBC 1903A.8 and the following;
 - 1. All welding performed by certified welders.
 - 2. All reinforcement requires preheat prior to welding. All preheat and welding shall be continuously inspected by the Testing Agency.

3.06 MISPLACED REINFORCEMENT

- A. Notify Architect/Engineer immediately if reinforcing bars are known to be misplaced after concrete has been placed.
- B. Perform no correction or cutting without specific direction. Do not bend or kink misplaced bars.
- C. Correct misplaced reinforcing only as directed in writing by the Architect/Engineer. Bear all costs of redesign, new, or additional reinforcing required because of misplaced bars at Contractor's expense.

3.07 FIELD QUALITY CONTROL

- A. The Testing Agency as specified in the Article QUALITY ASSURANCE, will inspect the work for conformance to contract documents before concrete placement.
 - 1. Inspection: Provide inspection and verification of installed reinforcement. Confirm that the surface of the rebar is free of form release oil or other coatings.
 - 2. Inspect all preheat and welding activities for steel reinforcement, when these occur.
 - 3. Exception: Non-structural patios, driveways, and sidewalks do not require special inspection.

3.08 CLEANING

- A. Remove excess material and debris associated with this work from the job site.

END OF SECTION

SECTION 03 3000

CAST-IN-PLACE CONCRETE

PART 1 GENERAL

1.01 SUMMARY

- A. Section Includes: Provide all labor, materials, equipment and services to complete all concrete work required, including, but not limited to, the following:
1. Foundations, beams, columns, elevated slabs, slabs-on-grade, walls, and retaining walls.
 2. Installation of all bolts, inserts, sleeves, connections, etc. in the concrete.
 3. Joint devices associated with concrete work.
 4. Miscellaneous concrete elements, including, but not limited to: equipment pads, light pole bases, flagpole bases, thrust blocks, and manholes.
 5. Concrete curing.
 6. Coordination with other sections:
 - a. Make all preparations and do all work necessary to receive or adjoin other work. Install all bolts and anchors, including those furnished by other sections, into formwork and provide all required blocking.
 - b. Install all accessories embedded in the concrete and provide all holes, blockouts and similar provisions necessary for the work of other sections. Provide all patching or cutting made necessary by failure or delay in complying with this requirement at the Contractor's expense.
 - c. Coordinate with other sections for the accurate location of embedded accessories.
- B. Related Sections:
1. Pertinent Sections of Division 01 specifying Quality Control and Testing Laboratory services.
 2. Pertinent Sections of Division 03 specifying concrete construction.
 3. Pertinent Sections of other Divisions specifying work to be embedded in concrete or work penetrating concrete.
 4. Pertinent sections of other Divisions specifying floor finishes and sealants applied to concrete substrates.

1.02 REFERENCES

- A. California Code of Regulations, Title 24, latest adopted edition (herein noted as CBC) Chapter 19A Concrete.
- B. American Concrete Institute (ACI) 211.1 "Standard Practice for Selecting Proportions for Normal, Heavyweight, and Mass Concrete"; ACI 211.2 "Standard Practice for Selecting Proportions for Lightweight Concrete".
- C. ACI 301 "Specifications for Structural Concrete".
- D. ACI 302.1R "Guide for Concrete Floor and Slab Construction".
- E. ACI 304R "Guide for Measuring, Mixing, Transporting, and Placing Concrete".

- F. ACI 305R "Hot Weather Concreting".
- G. ACI 306R "Cold Weather Concreting".
- H. ACI 308 "Standard Practice for Curing Concrete".
- I. ACI 318 "Building Code Requirements for Reinforced Concrete and Commentary".

1.03 SUBMITTALS

- A. Submit in accordance with pertinent sections of Division 01 specifying submittal procedures. The General Contractor shall review and approve shop drawings prior to submittal to the Architect/Engineer. Submittals that do not meet these requirements will be returned for correction without review. Submit for review prior to fabrication.
- B. Limitation of Review: Structural Engineer's review will be for general conformance with design intent as indicated in the Contract Documents and does not relieve Contractor of full responsibility for conformance with the Contract Documents.
- C. Product Data: Submit manufacturers' data on manufactured products and other concrete related materials such as bond breakers, cure/sealer, admixtures, etc. Demonstrate compliance with specified characteristics. Provide samples of items upon request. Submit material certificates for concrete aggregates and cementitious materials. Certificates shall show compliance to applicable ASTM's, the CBC, and additional requirements stated herein.
- D. Mix Designs: Submit Mix Designs for each structural concrete type required for work per requirements of articles CONCRETE MIXES and QUALITY ASSURANCE. Resubmit revised designs for review if original designs are adjusted or changed for any reason. Non-Structural mixes need not be submitted for review by Structural Engineer.
- E. Shop Drawings: Proposed location of construction and cold joints. Proposed location of all slab construction/dowel joints, control joints, and blockouts.
- F. Manufacturer's Installation Instructions: Indicate installation procedures and interface required with adjacent construction for concrete accessories.
- G. Batch Plant Certificates: Include with delivery of each load of concrete. Provide Certificates to the Testing Agency and the Architect/Engineer as separate submittals. Concrete delivered to the site without such certificate shall be rejected and returned to the plant. Each certificate shall include all information specified in Article SOURCE QUALITY CONTROL below.
- H. Engineering Analysis: Prepared by a California-licensed Civil or Structural Engineer, justifying construction-imposed loads on slabs, beams, and walls which exceed those allowed by CBC for the specified use.
 - 1. 2000 lbs maximum allowable construction load without analysis.
 - 2. 10,000 lbs maximum allowable construction load with analysis.
- I. Project Record Documents: Accurately record actual locations of embedded utilities and components that will be concealed from view upon completion of concrete work.

1.04 QUALITY ASSURANCE

- A. Perform work of this section in accordance with ACI 301 and ACI 318.
- B. Concrete construction verification and inspection to conform to CBC 1705A.3.
- C. Common Sourcing: Provide each of the following materials from a single source for entire project.
 - 1. Cement.
 - 2. Fly ash.
 - 3. Aggregate.
- D. Follow recommendations of ACI 305R when concreting during hot weather. Follow recommendations of ACI 306R when concreting during cold weather.
- E. Services by the Independent Testing Agency (includes "Special" Inspections) as specified in this Section and as follows:
 - 1. Perform tests and inspections specified below in articles SOURCE QUALITY CONTROL and FIELD QUALITY CONTROL. Duties and limitations of Independent Testing Agency, test costs and reports to be in conformance with pertinent Sections of Division 01.
- F. Contractor shall bear the entire cost of remediation, removal, and/or replacement of concrete determined defective or non-conforming, including Architect/Engineer fees for redesign.

1.05 DELIVERY, STORAGE, AND HANDLING

- A. Materials specified by brand name shall be delivered in unbroken packages bearing manufacturer's label and shall be brand specified or an approved equal.
- B. Delivery, Handling and Storage of other materials shall conform to the applicable sections of the current editions of the various reference standards listed in this Section.
- C. Protect materials from weather or other damage. Sort to prevent inclusion of foreign materials.
- D. Specific Requirements:
 - 1. Cement: Protect against dampness, contamination, and warehouse set. Store in weather tight enclosures.
 - 2. Aggregates: Prevent excessive segregation, or contamination with other materials or other sizes of aggregates. Use only one supply source for each aggregate stock pile.
 - 3. Admixtures:
 - a. Store to prevent contamination, evaporation, or damage.
 - b. Protect liquid admixtures from freezing and extreme temperature ranges.
 - c. Agitate emulsions prior to use.

1.06 ENVIRONMENTAL REQUIREMENTS

- A. Cold Weather (Freezing or near-freezing temperatures) per ACI 306R:

1. Heat concrete materials before mixing, as necessary to deposit concrete at a temperature of at least 50°F but not more than 90°F.
2. Do not place concrete during freezing, near-freezing weather, snow, rain or sleet unless protection from moisture and/or cold is provided.
3. Protect from freezing and maintain at a temperature of at least 50°F for not less than seven days after placing. Take special precautions to protect transit-mixed concrete.
4. No salts, chemical protection or admixture are permitted without written approval of Architect/Engineer.
5. Contractor shall maintain an air temperature log for the first 7 days after placement with entry intervals not to exceed 8 hours.

B. Hot Weather per ACI 305R:

1. Cool concrete materials before mixing, or add ice in lieu of mix water as necessary to deposit concrete at a temperature below 85°F.
2. Do not place concrete in hot/windy weather without Architect/ Engineer review of procedures.
3. Provide sunshades and/or wind breakers to protect flat work during finishing and immediate curing operations. Do not place flatwork concrete at air temperature exceeding 90°F.
4. Provide modified mix designs, adding retarders to improve initial set times and applying evaporation reducers during hot/windy weather for review by Independent Testing Agency prior to use.

1.07 MOCK-UP

- A. Construct and erect mock-up panel for architectural concrete surfaces indicated to receive special treatment or finish, as result of formwork.
 1. Panel Size: Sufficient to illustrate full range of treatment.
 2. Number of Panels: 2.
 3. Locate as indicated on drawings.
- B. If requested by Architect / Engineer, cast concrete against mock-up panel. Obtain acceptance of resulting surface finish prior to erecting formwork.
- C. Accepted mock-up panel is considered basis of quality for the finished work. Keep mock-up exposed to view for duration of concrete work.
- D. Mock-up may remain as part of the Work.

1.08 SCHEDULING AND SEQUENCING

- A. Organize the work and employ shop and field crew(s) of sufficient size to minimize inspections by the Testing Agency.
- B. Provide schedule and sequence information to Testing Agency in writing upon request. Update information as work progresses.

PART 2 PRODUCTS

2.01 FORMWORK

- A. Comply with requirements of Section 03 1000.

2.02 REINFORCEMENT

- A. Comply with requirements of Section 03 2000.

2.03 MATERIALS

- A. General Requirements: All materials shall be new and best of their class or kind. All materials found defective, unsuitable, or not as specified, will be condemned and promptly removed from the premises.
- B. Cementitious Materials:
 - 1. Portland Cement: ASTM C150, Type II, low alkali conforming to CBC 1903A.1.
 - 2. Fly Ash (Pozzolan): ASTM C618, Class F.
- C. Concrete Aggregates:
 - 1. Coarse and Fine Aggregates: ASTM C33; Stone aggregate and sand. Specific source aggregate and/or sand or shrinkage characteristics as required for class of concrete specified.
 - 2. Lightweight aggregate: ASTM C330 and C332.
 - 3. Source shall remain constant throughout the duration of the job. The exact portions of the fine aggregates and coarse aggregates to be used in the mix shall be determined by the mix design.
 - 4. Aggregates shall be tested for alkali reactivity per CBC section 1903A.6. Where test results exceed allowable limits, additional testing of mitigation procedures shall be provided, as outlined per CBC section 1903A.6.
- D. Water: Potable, clean, from domestic source.
- E. Admixtures: All admixtures shall be used in strict accordance with the manufacturer's recommendations. Admixtures containing calcium chlorides or other accelerators shall not be used without the approval of the Architect/Engineer and the Owner's Testing Laboratory.
 - 1. Mid Range Water Reducing Admixtures: ASTM C494 Type A, "MasterPolyHeed" (formerly "PolyHeed") series by BASF, "WRDA" series by W.R. Grace, or equal.
 - 2. High Range Water-Reducing Admixtures: ASTM C494 Type F, "MasterRheoBuild 1000" (formerly "RheoBuild 1000") or "MasterGlenium" (formerly "Glenium") series by BASF or equal.
 - 3. Water Reducing Admixture and Retarder: ASTM C494 Type B or D, "MasterPozzolith" (formerly "Pozzolith") series or "MasterSet DELVO" (formerly "DELVO") series by BASF, "Plastiflow-R" by Nox-crete, or equal.
 - 4. Air Entraining Admixtures: ASTM C260, product suit condition by BASF or equal.
 - 5. Viscosity Modifiers: ASTM C494 Type S.

- F. Slurry: Same proportion of cement to fine aggregates used in the regular concrete mix (i.e. only coarse aggregate omitted); well mixed with water to produce a thick consistency.
- G. High Strength Grout: See section 05 1200 or 05 1100 for requirements.
- H. Dry Pack: Dry pack (used only for cosmetic concrete repairs) shall consist of:
 - 1. One part cement to 2-1/2 parts fine aggregate (screen out all materials retained on No.4 sieve), mixed with a minimum amount of water, added in small amounts.
 - 2. Mix to consistency such that a ball of the mixture compressed in the hand will retain its shape, showing finger marks, but without showing any surface water.

2.04 ACCESSORIES

- A. Bonding Agent: ASTM C881, Type II Grade 2 Class B or C. Do not allow epoxy to set before placing fresh concrete.
 - 1. "MasterEmaco ADH 326" (formerly "Concresive Liquid LPL") by BASF;
 - 2. "Rezi-Weld 1000" by W.R. Meadows.
- B. Chemical Hardener: Fluorosilicate solution designed for densification of cured concrete slabs. "MasterKure HD 300 WB" (formerly "Lapidolith") by BASF, "LIQUI-HARD" W.R. Meadows Co, or equal.
- C. Moisture-Retaining Cover: ASTM C171, type 1, one of the following;
 - 1. Regular Curing Paper, Type I, reinforced waterproof: Fortifiber Corporation "Orange Label Sisalkraft", "Pabcotite" paper, or equal.
 - 2. Polyethylene Film: ASTM D 2103, 4 mil thick, clear or white color.
 - 3. White-burlap-polyethylene sheet, weighing not less than 10 oz/per linear yd.
- D. Liquid Curing Compound: ASTM C 309, Type 1, Class B, clear or translucent, 25% minimum solids, water base acrylic cure/sealer which will not discolor concrete and compatible with bonding of finishes specified in related sections. W.R. Meadows Co. "Vocomp 25" or equal. Maximum VOC content shall comply with local requirements and California Green Building Code.
- E. Underslab Water Vapor Retarder: See Section 07 2500 "Weather Barriers".
- F. Evaporation Reducer: "MasterKure ER 50" (formerly Confilm), by BASF.
- G. Permeability Reducer: Use only where specifically referred to.
 - 1. Admixture Type: Xypex Chemical Corporation "XYPEX Admix C-500". Dosage: 2-3% of cement content by weight; 15 lb/cu. yd. max. or BASF "MasterLife 300D" (formerly "Rheomac 300D"). Dosage: 2% of cement content by mass.
 - 2. Surface-Applied Type: Xypex Chemical Corporation "XYPEX Concentrate. Brush application: 1.25-1.50lb/sq. yd., 5 parts powder to 2 parts water. BASF "MasterSeal 500" (formerly "Tegraproof"). Slurry coat: one part water to 2.25-2.5 parts powder by volume.
 - 3. Approved equal.

2.05 JOINT DEVICES AND MATERIALS

- A. Waterstops: Resilient type, meeting Corps of Engineers CRD-C 572. Consult manufacturer for appropriate product for specific use. Submit for review. Install per manufacturers recommendation. Provide W. R. Meadows "Seal Tight" PVC waterstop, Sika "Greenstreak" PVC waterstop, or approved equal.
- B. Expansion Joint Filler: ASTM D1751, Nonextruding, resilient asphalt impregnated fiberboard or felt, 3/8 inch thick and 4 inches deep; tongue and groove profile.
 - 1. Products: "Servicised Products", W.R. Meadows, Inc., "National Expansion Joint Company", "Celotex Corporation", or equal.
- C. Joint Filler: ASTM D944, Compressible asphalt mastic with felt facers, 1/4 inch thick and 4 inches deep.
- D. Sealant and Primer: As specified in Section 07 9105.
- E. Slab Joint Sealant: Compatible with floor finishes specified in related sections.

2.06 CONCRETE MIXES

- A. General requirements for mix design and submittal of structural class concrete:
 - 1. Provide Contractor submittals to Architect/Engineer not less than 15 days before placing concrete.
 - 2. Contractor shall review mix designs and proposed placing requirements prior to submittal for compatibility to ensure that the concrete as designed can be placed in accordance with the drawings and specifications.
 - 3. Changes or revisions require re-submittal: All variations to approved mix designs, including changing type and/or quantity of admixtures shall be resubmitted to the Architect/Engineer for review prior to use.
 - 4. Mix design(s) for all structural classes of concrete to be prepared by qualified person experienced in mix design. Allow for time necessary to do trial batch testing when required.
 - 5. Preparer to provide backup data and certify in writing that mix design meets:
 - a. Requirements of the specifications for concrete durability and quality;
 - b. Requirements of the California Building Code and ACI 318 Section 26.4, including break histories, trial batching test results, and/or a mix designed by a California Registered Civil Engineer per ACI 318 Section 26.4.3.1(b) and bearing the Engineer's seal & signature.
 - 6. Clearly note on mix designs with specified maximum WCR if design permits addition of water on site, or clearly identify in the mix design that no water is to be added on site.
 - 7. Deviations: Clearly indicate proposed deviations, and provide written explanation explaining how the deviating mix design(s) will provide equivalent or better concrete product(s) than those specified.
 - 8. Include adjustments to reviewed mix designs to account for weather conditions and similar factors.
- B. Proportioning - General: The following provisions apply to all mix designs:

1. Proportion concrete mixes to produce concrete of required average strength (as defined by California Building Code Section 1904A and ACI 318 Section 19.2.1). Select slump, aggregate sizes, shrinkage, and consistency that will allow thorough compaction without excessive puddling, spading, or vibration, and without permitting the materials to segregate, or allow free water to collect on the surface.
 2. Select aggregate size and type to produce dense, uniform concrete with low to moderate shrinkage, free from rock pockets, honeycomb and other irregularities.
 3. Mix designs may include water reducing and retarding admixtures to meet or exceed minimum set times (time required to place and finish) and to minimize Water Cement Ratios (WCR). Minimum and maximum criteria presented in this section are guidelines and do not represent a specific mix design.
 4. Cement Content: Minimum cement content indicates minimum sacks of cementitious material. Increasing cement content to increase early strengths or to achieve specified WCR while maintaining water content is discouraged in order to minimize effects of shrinkage.
 - a. Substitution of fly ash for Portland cement on an equivalent weight basis up to 25% replacement is permitted, except at high early strength concrete. Replacement in excess of 25% is not permitted unless part of a specified mix design that has been submitted for review.
 - b. Such substitution requests may be denied by the Engineer.
 5. Water Content: Mix designs with a specified maximum Water Cement Ratio (WCR) may be designed with a lower WCR than specified in order to allow addition of water at the site.
 6. Concrete Strength: Establish required average strength for each type of concrete on the basis of field experience or trial mixtures, as specified in ACI 301 and this section.
 - a. For trial mixtures method, employ independent testing agency acceptable to Architect/Engineer for preparing and reporting proposed mix designs.
 7. Placement Options: Mix designs may, at the Contractor's option, be designed for either pump or conventional placement with aggregate size, slumps, etc. to be maintained as specified in this section.
- C. Proportioning Normal Weight Concrete: Comply with ACI 211.1 recommendations and this section.
- D. Proportioning Structural Lightweight Concrete: Comply with ACI 211.2 recommendations and this section. Maximum cured weight of lightweight concrete shall be 110 pounds per cubic feet.
- E. Special mix design requirements for interior concrete floor slabs on grade to receive floor coverings or coatings:
1. Proportion concrete mixes per this specification, ACI 211.1, and the requirements below:
 2. Minimum strength at 28 days to be 3000 psi; minimum strength at 56 days to be 4000 psi.
 3. Fly Ash Type F, shall be substituted for cement on a 1 lb. per 1 lb. basis, with a minimum replacement of 25% and a maximum of 35%. Mix design must comply with CBC 1903A.5 requirements.
 4. 200 lbs. of 3/8(-) aggregate shall be added to reduce total sand.
 5. Reduce total sand to minimum practical.
 6. Admixture dosage shall be per manufacturer's recommendations. Dosage may be increased for workability as long as set times are not excessive for placement and finishing.
- F. Special mix design requirements for high volume fly ash concrete:

1. Proportion concrete mixes per this specification, ACI 211.1, and the requirements below:
2. Fly Ash Type F, shall be substituted for cement on a 1 lb. per 1 lb. basis, with a replacement of 50%.
3. Minimum strength at 28 days to be 2500 psi; minimum strength at 56 days to be 3000 psi.
4. Add 200-300 pounds 3/8" aggregate to replace portion of fine aggregate.
5. Admixture dosage shall be per manufacturer's recommendations. Dosage may be increased for workability as long as set times are not excessive for placement and finishing.
6. Concrete shall be wet cured per CONCRETE CURING.

G. Mix Design Minimum Requirements:

| Concrete Class | Coarse Aggregate Size (Inches) & Fine Aggregate ³ | Maximum WCR or Maximum Nominal Slump & Tolerance (Inches) ^{1,2} | Minimum 28-Day Design Strength | Minimum Cement Sacks/per yd ⁴ |
|---|--|--|--------------------------------|--|
| NON-STRUCTURAL | | | | |
| 1) Lean Concrete (use only where specified) | --- | --- | --- | 3.0 |
| 2) Slab on Grade Exterior (Walks & Patios) | 1" x #4 | 4" ± 1" | 2,500 | 4.5 |
| STRUCTURAL | | | | |
| 3) Interior Slab on Grade w/floor coverings/coatings ⁵ | 1" x #4 | WCR = .45 | — | 6.1 |
| 4) Interior Slab on Grade w/o floor coverings/coatings | 1" x #4 | WCR = .45 | 3,000 (4,000 at 56-days) | 5.0 |
| 5) Foundation (including stem walls) | 1" x #4 | WCR = .53 | 3,000 | 5.0 |
| 6) Columns, Walls, Retaining Walls & Beams | 1" x #4 | WCR = .46 | 4,000 | 6.0 |
| 7) Drilled Pier | 3/4" x #4 | WCR = .53 | 3,000 | 5.0 |
| 8) Light Weight Concrete | 3/4" x #4 Expanded Shale | 3" ± 1/2" | 3,000 | 5.5 |
| 9) High Volume Fly Ash Concrete ⁶ | 1" x #4 | WCR = .45 | — | 6.0 |

1. The tolerance is the maximum deviation allowable without rejection. The mix design shall be based on the nominal value specified and is without water reducing mixtures. Slump to be measured at the end of the hose.
2. The maximum water cement ratio (WCR) is limited at time of placement as noted. No water is to be added on site such that the specified WCR or maximum slump is exceeded without approval of the testing laboratory and the Architect/Engineer. Workability is to be achieved utilizing an acceptable mid range to high range water reducing admixture.
3. Gradation of aggregate is per CBC Section 1903A, ACI 318 section 26.4.1.2, and ASTM C33.
4. Minimum cement content includes all cementitious materials.
5. See Article 2.06E for additional requirements at slabs on grade with coverings/coatings.
6. See article 2.06F for additional requirements at high volume fly ash concrete.

2.07 MIXING CONCRETE

- A. Batch final proportions in accordance with approved mix designs. All adjustments to approved proportions, for whatever reason, shall be reviewed by the Architect/Engineer prior to use.
- B. Batch and mix concrete in accordance with ASTM C94, at an established plant. Site mixed concrete will be rejected.

- C. Provide batch and transit equipment adequate for the work. Operate as necessary to provide concrete complying with specified requirements.
- D. Place mixed concrete in forms within 1-1/2 hours from the time of introduction of cement and water into mixer or 300 revolutions of the drum whichever comes first. Use of, re-mixing, and/or tempering mixed concrete older than 1 hour will not be permitted.
- E. Do not add water at the site to concrete mixes with a maximum specified WCR unless the water content at batch time provides for a WCR less than specified and this provision, including the quantity of water which may be added at the site, is specifically noted on the mix design and certification by the mix preparer. See ASTM C94 for additional requirements.

2.08 SOURCE QUALITY CONTROL

- A. Services by independent Testing Agency:
 - 1. Where aggregate alkali reactivity testing (and, when applicable, mitigation testing) per the MATERIALS section is not available, the Testing Agency shall perform this testing to verify materials conformance to CBC section 1903A.5.
 - 2. Batch Plant inspection at automated plants to occur at commencement of concrete work each day (first truck). Batch Plant inspection at non-automated plants and when accuracy is questionable shall be continuous. Additionally, water cement ratio (WCR) is to be verified where a WCR is specified herein. The computed WCR is to be written on the Batch Plant Certificate to be taken to the job site prior to the truck leaving the plant. See requirements of CBC 1705A.3.3.
 - 3. Batch Plant Certificates: Obtain the weighmaster's Batch Plant Certificate at arrival of truck at the site. If no batch plant certificate is provided, recommend to the General Contractor that the truckload of concrete be rejected. So note in daily log, along with the location of the load of concrete in the structure if the load is not rejected. See requirements of CBC 1705A.3.3.
 - a. Laboratory's inspector shall obtain for each transit mixer Batch Plant Certificates to verify mix design quantities and condition upon delivery to the site.
 - b. Certificates to include: Date, time, ingredient quantities, water added at plant and on job, total mixer revolutions at time of placement, and time of departure.
 - c. Concrete with specified water cement ratio: Add no water on site unless mix design and batch records each show additional water may be added. See ASTM C94 for additional requirements.

PART 3 EXECUTION

3.01 EXAMINATION

- A. Verify lines, levels, and dimensions before proceeding with work of this section.
- B. Verify work of other sections is complete and tested as required before proceeding.

3.02 PREPARATION

- A. Observation, Inspection and Testing:

1. Architect/Engineer: Notify not less than 2 working days before each concrete placement, for observation and review of reinforcing, forms, and other work prior to placement of concrete.
 2. Testing Agency: Notify not less than 24 hours before each placement for inspection and testing.
- B. Placement Records: Contractor shall maintain records of time, temperature and date of concrete placement including mix design and location in the structure. Retain records until completion of the contract. Make available for review by Testing Agency and Architect/Engineer.
- C. Coordinate placement of joint devices with erection of concrete formwork and placement of form accessories.
- D. Verify location, position and inclusion of all embedded and concealed items.
- E. Verify installation of vapor retarder under interior slabs on grade, as specified in related section, is complete.
- F. Cleaning and Preparation:
1. Remove loose dirt, mud, standing water, and foreign matter from excavations and cavities.
 2. Close cleanout and inspection ports securely.
 3. Thoroughly clean reinforcement and other embedded items free from loose rust and foreign matter. Maintain reinforcing securely in place. Do not place concrete on hot reinforcing.
 4. Dampen form materials and substrates on which concrete is to be placed at least 1 hour in advance of placing concrete; repeat wetting as necessary to keep surfaces damp. Do not saturate. Do not place concrete on saturated material.
 - a. Thoroughly wet wood forms (except coated plywood), bottom and sides of trenches, adjacent concrete or masonry and reinforcement.
 - b. Concrete slabs on base rock, dampen rock.
 - c. Concrete slabs on vapor retarder, do not wet vapor retarder.
 5. Verify that metal forms are clean and free of rust before applying release agent.
 6. Thoroughly clean metal decking. Do not place concrete on wet deck surface.
 7. Prepare previously placed concrete by cleaning with steel brush and applying bonding agent in accordance with manufacturer's instructions.
- G. Drill holes in existing concrete at locations where new concrete is doweled to existing work. Insert steel dowels and prepare connections as detailed.
- H. Do not overcut at existing concrete work to remain. Contractor is responsible for repair/replacement of overcut concrete to the Owner's satisfaction.

3.03 PIPES AND CONDUITS IN CONCRETE

- A. Slabs-on-Grade:
1. No pipe or conduit exceeding 1 inch outside diameter shall be embedded within the specified slab thickness except as specifically detailed.
 2. Do not stack or abut pipes, maintain 3 inches minimum clearance.
- B. Sleeving and Wrapping:

1. Foundations: Sleeve or wrap all individual pipe penetrations, minimum 1-1/2 inches clear to reinforcing all around.
 - a. Sleeves: PVC. Provide 1 inch minimum clear all around O.D. pipe to I.D sleeve, UNO at ends, fill void space with mastic or plastic bituminous cement.
 - b. Wrapped Vertical Pipes: Provide 1/8 inch nominal sheet foam with three wraps minimum, UNO.
 - c. Wrapped Horizontal Pipes: Provide 1/8 inch nominal sheet foam with eight wraps minimum, UNO.
 - d. Underground Fire Lines 4" and Larger: At sleeves provide 2 inch minimum clear all around O.D. pipe to I.D sleeve. At wrapped pipes, provide 1/8 inch nominal sheet foam with sixteen wraps minimum.
 2. Slabs or Curbs: Wrap pipes as described above.
- C. Space groups of pipes/conduits at least 3 sleeve diameters apart, do not interrupt specified concrete and reinforcement.
1. Provide block-outs as detailed when grouping of pipes/conduits in foundation or other structural member prevents spacing as described. Notify Architect/Engineer for review of any conditions not conforming to details.
 2. Center pipe/conduit penetrations in the depth and/or thickness of foundations.
 3. Maximum size of pipe/conduit penetrations shall not exceed the least dimension of concrete divided by 3.
- D. Do not embed pipes/conduits in concrete slabs on metal deck.
- E. Provide the following at pipes/conduits detailed to be embedded in a concrete beam, wall or column:
1. Place as near as possible to center of member with reinforcing as specified on each side.
 2. Where reinforcing is located near or at center of member, place pipe or conduit 1 inch minimum clear from reinforcing and provide #3 at 12 inches on center perpendicular to the pipe/conduit. Reinforcing to extend 12 inches minimum past pipe/conduit each side.
 3. Maintain 3/4 inch clear minimum from added reinforcing to face of concrete where not exposed to weather and 1-1/2 inches clear where exposed to weather.
 4. Space embedded items (groups of pipe/conduit, junction boxes or other elements) minimum 3 inches apart.
 5. Provide reinforcing in walls, beams, columns as detailed for groups of pipe/conduit. Provide minimum replacement reinforcement of same size and number for interrupted or displaced reinforcement for the full height, length, width of the wall, beam, and/or column on each side of the "effective opening."

3.04 CONCRETE PLACEMENT

- A. Transporting:
1. Provide clean, well-maintained equipment of sufficient quantity and capacity to execute the work and produce concrete of quality specified.
 2. Handle and transport concrete from mixer to final deposit location as rapidly as practicable. Prevent separation or loss of ingredients.

- B. Perform concrete placement by methods which will not puncture, damage or disturb vapor retarder membrane. Repair all damage to vapor retarder membrane before covering.
- C. Placement - General: Placement, once started, shall be carried on as a continuous operation until section of approved size and shape is completed. Provide construction joints as detailed on the drawings. Engineer's written approval required for all deviations.
 - 1. Deposition:
 - a. Deposit concrete to maintain an approximately horizontal plastic surface until the completion of the unit placement.
 - b. Deposit as neatly as practicable in final position, minimize re-handling or flow.
 - c. Do not drop concrete freely where reinforcing bars, embeds, or obstructions occur that may cause segregation. Provide spouts, elephant trunks, or other means to prevent segregation during placement.
 - 2. Depth: Layered placement in columns and walls shall not exceed ten feet vertical depth.
 - a. Place concrete in minimum 32 inch horizontal lifts.
 - b. Schedule placement to ensure that concrete will not take initial set before placement of next lift.
 - c. No horizontal cold joints are allowed in columns or walls.
 - 3. Progress Cleaning: Remove all concrete spilled on forms or reinforcing steel in portions of structure not immediately concreted. Remove completely before concrete sets.
 - 4. Interruptions: Shut down placement operations and dispose of all remaining mixed concrete and concrete in hoppers or mixers following all interruption in placement longer than 60 minutes.
 - a. If such interruption occurs, provide new or relocate existing construction joints as directed by Engineer.
 - b. Cut concrete back to the designated line, cleaning forms and reinforcing as herein specified.
 - c. Prepare for resumption of placement as for new unit when reason for interruption is resolved.
- D. Placement - Elevated Structural Systems: Place as noted for "General" above and as follows:
 - 1. Metal Decking and Structural Steel Beam Systems that are not to be shored: Locate screed lines on primary structural members. Review proposed screed line locations and expected structural deflections with the Architect/Engineer prior to placement of concrete.
 - 2. Place screed lines to match camber of primary girders made of material other than concrete. Locate screeds to provide the minimum specified thickness of concrete at all locations.
 - 3. Compensate for deflection of intermediate structural members and decking by placement of additional concrete.
 - 4. Adjust embedded items to compensate for camber and deflection. Maintain locations within specified tolerances.
- E. Consolidation:
 - 1. Consolidate all concrete thoroughly during placement with high-speed mechanical vibrators and other suitable tools. Perform manual spading and tamping to work around reinforcement, embedded fixtures, and into corners of formwork as required to obtain thorough compaction.
 - a. Provide vibrators with sufficient amplitude for adequate consolidation.

- b. Use mechanical vibrators at each point of concrete placement.
 - c. Keep additional spare vibrators, in addition to those required for use, at the site for standby service in case of equipment failure.
2. Consolidate each layer of concrete as placed.
 - a. Insert vibrators vertically at points 18 to 30 inches apart; work into top area of previously placed layer to reconsolidate, slowly withdraw vibrator to surface.
 - b. Avoid contact of vibrator heads with formwork surfaces.
 - c. Systematically double back and reconsolidate wherever possible. Consolidate as required to provide concrete of maximum density with minimized honeycomb.
- F. Unacceptable Materials:
1. Do not place concrete that has started to set or stiffen. Dispose of these materials.
 2. Do not add water on site to concrete except as specified in the approved mix design, see PART 2 above.
- G. Protection of installed work:
1. Do not introduce any foreign material into any specified drainage, piping or duct systems.
 2. Contractor shall bear all costs of work required to repair or clean affected work as a result of failure to comply with this requirement.

3.05 CONCRETE JOINTS

- A. Structural Joints (Construction/Cold Joints):
1. Locate joints only where shown, or as approved.
 2. Review Required: Joints not indicated on the plans shall be located to meet the minimum requirements below, shall not impair the strength of the structure and shall be submitted to Architect/Engineer for review prior to placement of concrete.
 - a. Indicate proposed location(s) of construction/cold/expansion joints on shop drawing submittals for review prior to placing concrete.
 3. Clean and roughen all surfaces of previously placed concrete at construction joints by washing and sandblasting to expose aggregate to 1/4 inch amplitude.
 4. Slabs-On-Grade: Maximum Length of continuous placement shall not exceed 60 feet without special review by the Architect/Engineer. Alternate or stagger placement sections.
 5. Foundations, Beams, Elevated Slabs and Joists: Maximum Length of continuous placement shall not exceed 200 foot increments. Provide "keyed" shut-off locations made up with form boards. Extend reinforcing one lap length or more through shut-off.
 - a. All reinforcement shall be continuous through construction/cold joint, lapping to adjacent reinforcing in future placement.
 - b. Construction Joints in Elevated Slabs: Review all proposed locations with Architect/Engineer.
 - c. Construction Joints in Slabs on Metal Decking: Review all proposed locations with Architect/Engineer. Do not locate closer than 24 inches to faces of girder or beam.
 6. Horizontal Construction Joints: Place 2 inch slurry (specified concrete mix less coarse aggregate) at beginning of pour at the bottom of walls unless a prior review of a mock-up section demonstrates that segregation of aggregate will not occur.
- B. Expansion/Construction Joints (Dowel Joints and Control Joints):

1. Interior and Exterior Floor Slabs-on-Grade:
 - a. Expansion/Construction Joints: Provide dowel joints or control joints at a maximum dimension (in feet) of three times the slab thickness (in inches) in each direction unless noted otherwise (15'-0" maximum). Install joints to match slab level and in straight lines. Locate joints at all reentrant corners including blockouts.
 - b. Proportions: Install joints to divide slab into rectangular areas with long dimensions less than 1.5 times short dimension.
2. Exterior Concrete Paving (walkways, patios) and other non-structural concrete flatwork at grade:
 - a. Expansion/ construction joints: Provide a 2 inch deep troweled groove or asphalt impregnated joint material embedded 50 percent of the slab depth at 12 feet on center, maximum.
 - b. Proportions: Place no section with a length larger than two times width.
Additionally, place joints at all inside corners and at all intersections with other work.
3. Elevated Structural Slabs: Locate construction joints as specifically indicated on the drawings. All additional proposed locations shall be reviewed by the Architect/Engineer prior to placement.

C. Joint Types:

1. Dowel Joint: A keyed joint with smooth dowels passing through to allow unrestricted movement due to contraction and expansion. Joints are as specified on the drawings.
2. Control Joint(s): Shrinkage crack control joints may be of the following types when shown on the drawings. Install joints in a straight line between end points with edges finished appropriate to type. Depth shall be 25% of the slab thickness, unless noted otherwise. Fill joints with sealant as shown on the drawings or as required by related sections.
 - a. 1/4 inch wide troweled joint.
 - b. Keyed joint: Only at locations where concealed by other finishes.
 - c. Masonite Strip, 1/8 inch: Only at locations where concealed by other finishes.
 - d. Saw Cut, 1/8 inch: Must be performed within eight hours of completion of finishing. Do not make saw cuts if aggregate separates from cement paste during cutting operation. Prevent marring of surface finish. Fill with flexible sealant.

3.06 VAPOR RETARDER

- A. Vapor Retarder Installation: Install as specified in Section 07 2500 "Weather Barriers", ASTM E1643, and per manufacturer's recommendations including taping and lapping of seams, sealing of penetrations, and repair of damage. Do not extend vapor retarder below footings.

3.07 FLATWORK

A. General Requirements for All Concrete Formed & Finished Flat:

1. Edge Forms and Screeds: Set accurately to produce indicated design elevations and contours in the finished surface, edge forms sufficiently strong to support screed type proposed.
2. Jointing: Located and detailed as indicated.
3. Consolidation: Concrete in slabs shall be thoroughly consolidated.

B. Flatwork Schedule:

1. Exterior Slabs-On-Grade: Place concrete directly over sub-base as indicated.
 - a. Sub-Base: Clean free-draining, crushed base rock, 6 inch minimum thickness, thoroughly compacted.
2. Interior Slabs-On-Grade without floor covering:
 - a. Sub-Base: Clean free-draining, crushed base rock, 6 inch minimum thickness, thoroughly compacted.
3. Concrete Slabs-On-Grade with floor coverings specified in related sections:
 - a. Sub-Base: Clean free-draining, crushed base rock, 6 inch minimum thickness, thoroughly compacted.
 - b. Vapor Retarder: Install over sub-base.

3.08 FORMED SURFACES

- A. Form all concrete members level and plumb, except as specifically indicated. Comply with tolerances specified in ACI 318 Section 26.11, ACI 301 Section 2, and this specification, except that maximum permissible deviation is 1/4 inch end-to-end for any single member.
- B. Cambers: Provide all cambers indicated in the formwork construction. Set screeds to produce specified cambers in the finished concrete.

3.09 CONCRETE FINISHES

- A. Flatwork Finishing:
 1. Perform with experienced operators.
 2. Finish surfaces monolithically. Establish uniform slopes or level grades as indicated. Maintain full design thickness.
 3. In areas with floor drains, maintain design floor elevation at walls; slope surfaces uniformly to drains as indicated on drawings.
 4. Flatwork Finish Types:
 - a. Wood Float Finish: Surfaces to receive quarry tile, ceramic tile, or cementitious terrazzo with full bed setting system, or wood frame for raised finished floors.
 - b. Steel Trowel Finish: Surfaces to receive carpeting, resilient flooring, seamless flooring, thin set terrazzo, thin set tile or similar finishes specified in related sections. Trowel twice, minimum.
 - c. Broom Texture Finish: Exterior surfaces as indicated or for which no other finish is indicated. Finish as for steel trowel finish, except immediately following first troweling, (depending on conditions of concrete and nature of finish required) provide uniform surfaces texture using a medium or coarse fiber broom.
- B. Other Concrete: Provide as required to achieve appearance indicated on structural and architectural drawings and related sections.
 1. Repair surface defects, including tie holes, immediately after removing formwork.
 2. Unexposed Form Finish: Rub down or chip off fins or other raised areas 1/4 inch or more in height.
 3. Exposed Form Finish: Finish concrete to match forms. Rub down or chip off and smooth fins or other raised areas 1/4 inch or more in height. Provide finish as follows:
 - a. Smooth Rubbed Finish: Wet concrete and rub with carborundum brick or other abrasive, not more than 24 hours after form removal.

- b. Grout Cleaned Finish: Wet areas to be cleaned and apply grout mixture by brush or spray; scrub immediately to remove excess grout. After drying, rub vigorously with clean burlap, and keep moist for 36 hours.
 - c. Cork Floated Finish: Immediately after form removal, apply grout with trowel or firm rubber float; compress grout with low-speed grinder, and apply final texture with cork float.
4. Intermediate joint and score marks and edges: Tool smooth and flush unless otherwise indicated or as directed by the Architect.
 5. Use steel tools of standard patterns and as required to achieve details shown or specified. All exposed corners not specified to be chamfered shall have radiused edges.

3.10 TOLERANCES

- A. Minimum Flatwork Tolerances: Measure flatness of slabs within 48 hours after slab installation in accordance with ACI 302.1R and ASTM E1155 and to achieve the following FF and FL tolerances:
 1. Exterior surfaces: 1/8 inch minimum per foot where sloped to drain. Level otherwise. FF20 and FL15.
 2. Interior surfaces not otherwise shown or required: Level throughout. FF25 and FL20
 3. Interior surfaces required to be sloped for drainage: 1/8 inch in 10 ft.
 4. Finish concrete to achieve the following tolerances:
 - a. Under Glazed Tile on Setting Bed: FF30 and FL20.
 - b. Under Resilient Finishes: FF35 and FL25.
 - c. Flooring manufacturer and pertinent section of Division 9.
- B. Formed Surface Tolerances:
 1. Permanently Exposed Joints and Surfaces: Provide maximum differential height within two feet of, and across construction joints of 1/16 inch.
 2. Vertical Elevations: Elevation of surfaces shall be as shown or approved.

3.11 SEPARATE FLOOR TOPPINGS

- A. Prior to placing floor topping, roughen substrate concrete surface and remove deleterious material. Broom and vacuum clean.
- B. Place required dividers, edge strips, reinforcing, and other items to be cast in.
- C. Apply bonding agent to substrate in accordance with manufacturer's instructions.
- D. Apply sand and cement slurry coat on base course, immediately prior to placing toppings.
- E. Place concrete floor toppings to required lines and levels. Place topping in checkerboard panels not to exceed 20 feet in either direction.
- F. Scream toppings level, maintaining surface tolerances per above.

3.12 CONCRETE CURING

- A. Curing - General: Cure in accordance with ACI 308. Maintain concrete water content for proper hydration and minimize temperature variations. Begin curing immediately following finishing.
- B. Protection During Curing: Immediately after placement, protect concrete from premature drying, excessively hot or cold temperatures, and mechanical injury. The General Contractor is responsible for the protection of the finished slab from damage.
 - 1. Avoid foot traffic on concrete for minimum of 24-hours after placement.
 - 2. Protect concrete from sun and rain.
 - 3. Maintain concrete temperature at or above 50 degrees F. during the first 7 days after placement. See Article ENVIRONMENTAL REQUIREMENTS.
 - 4. Do not subject concrete to design loads until concrete is completely cured, and until concrete has attained its full specified 28-day compressive strength or until 21 days after placement, whichever is longer.
 - 5. Protect concrete during and after curing from damage during subsequent building construction operations. See Article PROTECTION.
- C. Maintain concrete with minimal moisture loss at relatively constant temperature for period necessary for hydration of cement and hardening of concrete.
 - 1. Normal concrete: Not less than 7 days.
 - 2. High early strength concrete: Not less than 4 days.
- D. Begin curing immediately following finishing.
- E. Formed Surfaces: Cure by moist curing with forms in place for full curing period.
- F. Surfaces Not in Contact with Forms:
 - 1. Start initial curing as soon as free water has disappeared and before surface is dry. Keep continuously moist for not less than 3 days by water ponding, water-saturated sand, water-fog spray, or saturated burlap.
 - 2. Begin final curing after initial curing but before surface is dry.
 - a. Moisture-retaining cover: Seal in place with waterproof tape or adhesive.
 - b. Curing compound: Apply in two coats at right angles, using application rate recommended by manufacturer.
- G. Flatwork on Grade: Cure by one of the following methods:
 - 1. Water Cure (Ponding): Maintain 100 percent coverage of water over floor slab areas, continuously for minimum 7 calendar days.
 - 2. Spraying: Spray water over floor slab areas and maintain wet for 7 days.
 - 3. Moisture-Retaining Film or Paper: Lap strips not less than 6 inches and seal with waterproof tape or adhesive; extend beyond slab or paving perimeters minimum 6 inches and secure at edges; maintain in place for minimum 7 days.
 - 4. Absorptive Moisture-Retaining Covering: Saturate burlap-polyethylene and place burlap-side down over floor slab areas, lapping ends and sides and extend beyond slab or paving perimeters 6 inches minimum; maintain in place for minimum 7 days.

5. Liquid Membrane-forming Curing Compound: Provide only when subsequent concrete treatments or finish flooring specified in related sections will not be affected by cure/sealer. Apply curing compound in accordance with manufacturer's instructions at the maximum recommended application rate in two coats, with second coat applied at right angles to first.
- H. Elevated Flatwork: Cure by one of the following methods.
1. Moisture-Retaining Sheet: As specified for Flatwork on Grade above.
 2. Water Cure: As specified above for minimum 14 days.
 3. Apply Membrane Curing Compound as specified above after initial curing period.
- I. Flatwork on Metal Decking: Moisture-Retaining Sheet method as specified above.
- J. Formed Concrete Members: Cure by moist curing with forms in place for full curing period.
1. Protect free-standing elements from temperature extremes.
 2. Maintain forms tight for minimum 7 days. Maintain exposed surfaces continuously damp and completely covered by sheet materials thereafter.
 3. Maintain all shoring in place. Refer to related sections specifying formwork.
 4. Membrane Curing Compound: Apply compound in accordance with manufacturer's instructions in one coat.
- K. Foundations: Apply curing compound immediately after floating.

3.13 CONCRETE HARDENER

- A. Apply hardener to all floor slabs not receiving other finishes after 30 days minimum curing. Clean slabs of non-compatible cure/sealers or other foreign material(s) and apply in strict accordance with the manufacturer's directions.

3.14 GROUTING AND DRY PACK

- A. Set steel plates on concrete or masonry with high strength grout bed, completely fill all voids; thoroughly compact in place. See Section 05 1200 or 05 1100.
- B. Bolts or inserts dry packed or grouted in place shall cure for minimum 7 days before tensioning.

3.15 FIELD QUALITY CONTROL

- A. Testing and Inspections by Independent Testing Agency: Provided verification and inspection of concrete per CBC Table 1705A.3. Provide written reports for to Engineer, Architect, Contractor and Building Official for the following tests and inspections:
- B. Testing & Inspection: Provide periodic inspection of reinforcing steel. Provide continuous inspection during placement of structural class concrete, 3000 psi or more. Non-structural class concrete with a design strength of 2500 psi or less to have periodic inspection on a 150 cubic yard basis as required to assure conformance.
1. Provide periodic inspection of bolts in concrete prior to and during placement where so noted on the construction documents.

2. Structural Concrete Cylinder Tests: Perform in accordance with ASTM C31.
 - a. Take four standard 6 inch x 12 inch (or five 4 inch x 8 inch) cylinder specimens on the site, of each class of concrete as specified in PART 2, not less than once a day or for each 50 cubic yards or 2000 sq ft or fraction thereof placed each day.
 - b. Record the location of each concrete batch in the building in a log and also note on each specimen.
 - c. Perform standard compression test of cylinders in accordance with ASTM C39, one at 7 days and two (three for 4x8 cylinders) at 28 days.
 - d. Hold fourth (fifth) cylinder untested until specified concrete strengths are attained.
3. Structural Concrete Slump Test and Air Tests: Perform in accordance with ASTM D143 and C231 or C173 at the time of taking test cylinders, and/or at one-hour intervals during concrete placing.
4. Measure and record concrete temperature upon arrival of transit mixers and when taking specimens. Note weather conditions and temperature.
5. Propose adjustments to reviewed mix designs for Architect / Engineer review to account for variations in site or weather conditions, or other factors as appropriate.
6. Water Vapor Transmission Tests: Floors receiving floor finishes specified in related sections will be tested prior to installation of flooring systems. Refer to sections specifying floor finishes for related requirements.

C. Services by Contractor:

1. Rejection of Concrete Materials: Do not use the following without prior written approval of the Architect/Engineer;
 - a. Materials without batch plant certificates.
 - b. Materials not conforming to the requirements of these specifications.

3.16 ADJUSTING

- A. Inspect all concrete surfaces immediately upon formwork removal. Notify Architect/Engineer of identified minor defects. Repair all minor defects as directed.
- B. Surface and Finish Defects: Repair as directed by the Architect/Engineer, at no added expense to the Owner. Repairs include all necessary materials; reinforcement grouts, dry pack, admixtures, epoxy and aggregates to perform required repair.
 1. Repair minor defective surface defects by use of drypack and surface grinding. Specific written approval of Architect/Engineer is required. Submit proposed patching mixture and methods for approval prior to commencing work.
 2. Slabs-on-Grade, Elevated Slabs and on Slabs on Metal Deck: Review for "curled" slab edges and shrinkage cracks prior to installation of other floor finishes. Grind curled edges flush, fill cracks of 1/16 inch and greater with cementitious grout.
 3. Grind high spots, fins or protrusions caused by formwork; Fill-in pour joints, voids, rock pockets, tie holes and other void not impairing structural strength. Provide surfaces flush with surrounding concrete.

3.17 DEFECTIVE CONCRETE

- A. Defective Concrete: Concrete not conforming to required compressive strength, lines, details, dimensions, tolerances, finishes or specified requirements; as determined by the Architect/Engineer.

- B. Repair or replacement of defective concrete will be determined by the Architect/Engineer who may order additional testing and inspection at his option. The cost of additional testing shall be borne by Contractor when defective concrete is identified.
- C. Specific Defects:
 - 1. "Low-Strength"; Concrete Not Meeting Specified Compressive Strength after 28 days:
 - a. Concrete with less than 25% Fly Ash as cementitious material: Test remaining cylinder(s) at 56 days. If strength requirements are met, concrete strength is acceptable.
 - b. Concrete with 25% or more Fly Ash as cementitious material: Test remaining cylinder(s) at 70 days. If strength requirements are met, concrete strength is acceptable.
 - 2. Excessive Shrinkage, Cracking, Cracking or Curling; Defective Finish: Remove and replace if repair to acceptable condition is not feasible.
 - 3. Lines, Details, Dimensions, Tolerances: Remove and replace if repair to acceptable condition is not feasible.
 - 4. Slab sections not meeting specified tolerances for trueness/flatness or lines/levels: Remove and replace unless otherwise directed by the Architect/Engineer. Minimum area for removal: Fifteen square feet area unless directed otherwise by the Architect/Engineer.
 - 5. Defective work affecting the strength of the structure or the appearance: Complete removal and replacement of defective concrete, as directed by the Architect/Engineer.

3.18 CLEANING

- A. Maintain site free of debris and rubbish. Remove all materials and apparatus from the premises and streets at completion of work. Remove all drippings; leave the entire work clean and free of debris.
- B. Slabs to Receive Floor Finishes Specified in other sections: Remove non-compatible cure/sealers or other foreign material(s) which may affect bonding of subsequent finishes. Leave in condition to receive work of related sections.

3.19 PROTECTION

- A. Protect completed work from damage until project is complete and accepted by Owner.
- B. Construction Loads: Submit engineering analysis for equipment loads (including all carried loads) specified in article submittals.
- C. Keep finished areas free from all equipment traffic for a minimum of 4 additional days following attainment of design strength and completion of curing.
- D. Protection of Drainage Systems:
 - 1. Care shall be taken not to introduce any foreign material into any specified drainage, piping or duct system.
 - 2. Cost of work to repair or clean drainage system as a result of failure to comply with this requirement will be back charged to the contractor.

- E. Cover traffic areas with plywood sheets or other protective devices; maintain protection in place and in good repair for as long as necessary to protect against damage by subsequent construction operations.

END OF SECTION

**SECTION 03 3511
CONCRETE FLOOR FINISHES**

PART 1 GENERAL

1.01 SECTION INCLUDES

- A. Surface treatments for concrete floors and slabs.

1.02 RELATED REQUIREMENTS

- A. Section 01 6116 - Volatile Organic Compound (VOC) Content Restrictions.
- B. Section 03 3000 - Cast-In-Place Concrete
- C. Section 07 9200 - Joint Sealers.
- D. Pertinent sections of Division 09 specifying concrete floor preparation for applied finishes.

1.03 REFERENCE STANDARDS

- A. ACI 301 - Specifications for Structural Concrete for Buildings; American Concrete Institute International.
- B. ACI 302.1R - Guide for Concrete Floor and Slab Construction; American Concrete Institute International.
- C. ASTM C39/C39M - Standard Test Method for Compressive Strength of Cylindrical Concrete Specimens.
- D. ASTM C 309 - Standard Specification for Liquid Membrane-Forming Compounds for Curing Concrete.
- E. ASTM C779 - Standard Test Method for Abrasion Resistance of Horizontal Concrete Surfaces.
- F. ASTM C805 - Standard Test Method for Rebound Number of Hardened Concrete.
- G. ASTM C1028 - Standard Test Method for Determining the Static Coefficient of Friction of Ceramic Tile and Other Like Surfaces by the Horizontal Dynamometer Pull-Meter Method.
- H. California Code of Regulations, Title 24, Part 11 California Green Building Standards Code, "CAL-Green".

1.04 ADMINISTRATIVE REQUIREMENTS

- A. Coordinate the work with concrete floor placement and concrete floor curing.

1.05 SUBMITTALS

- A. See Section 01 3300 - Submittals, for submittal procedures.
- B. Product Data: Manufacturer's published data on each finishing product, including information on compatibility of different products and limitations.
- C. VOC Submittals: Product Data - VOC Limits: For adhesives, sealants, fillers and primers, documentation including printed statement of VOC contents, comply with limits specified in Section 01 6116.
- D. Maintenance Data: Provide data on maintenance and renewal of applied finishes.

1.06 DELIVERY, STORAGE, AND HANDLING

- A. Deliver materials in manufacturer's sealed packaging, including application instructions.

1.07 FIELD CONDITIONS

- A. Maintain light level equivalent to a minimum 200 W light source at 8 feet above the floor surface over each 20 foot square area of floor being finished.
- B. Do not finish floors until interior heating system is operational.
- C. Maintain ambient temperature of 50 degrees F minimum.

PART 2 PRODUCTS

2.01 CONCRETE FLOOR FINISH APPLICATIONS

- A. Liquid Densifier/Hardener:
 - 1. Use at following locations: Locations indicated on the Drawings as "sealed concrete"..

2.02 DENSIFIERS AND HARDENERS

- A. Liquid Densifier/Hardener: Penetrating chemical compound that reacts with concrete, filling the pores and dustproofing; for application to concrete after set.
 - 1. Products:
 - a. Curecrete Distribution Inc.; Ashford Formula: www.ashfordformula.com.
 - b. Substitutions: See Section 01 6000 - Product Requirements.
 - 2. Performance Requirements:
 - a. Volatile Organic Content: 0 g/l.
 - b. Abrasion resistance (ASTM C779): At least 32.5% increase at 30 minutes.
 - c. Curing: At least 93% greater moisture retention during the initial critical 24 hour curing period compared to untreated samples.
 - d. Compressive strength (ASTM C39):
 - 1) At least 40% increase in compressive strength at 7 days compared to untreated samples.
 - 2) At least 38% increase at 28 days compared to untreated samples.
 - e. Impact resistance (ASTM C805): At least 13.3% increase in impact resistance compared to untreated samples.
 - f. Permeability 0.00073 oz (0.022 cc)/hour seepage rate using a 7'-0" (2.13 m) head of water and a 4.91 in² (3168 mm²) treated area.
 - g. Coefficient of Friction (ASTM C1028): 0.86 dry, 0.69 wet.

PART 3 EXECUTION

3.01 EXAMINATION

- A. Verify that floor surfaces are acceptable to receive the work of this section.
- B. Verify that flaws in concrete have been patched and joints filled with methods and materials suitable for further finishes.

3.02 GENERAL

- A. Apply materials in accordance with manufacturer's instructions.

3.03 FLOOR SURFACE TREATMENT

- A. Verify that surface is free of previous coatings, sealers, curing compounds, water repellents, laitance, efflorescence, fats, oils, grease, wax, soluble salts, residues from cleaning agents, and other impediments to adhesion.
- B. Protect adjacent non-coated areas from drips, overflow, and overspray; immediately remove excess material.
- C. Apply products to scheduled floor surfaces in accordance with manufacturer's instructions.

3.04 CLEANING AND PROTECTION

- A. Protect completed work from damage until cured as described by manufacturer and ready for traffic.

END OF SECTION

SECTION 05 1200

STRUCTURAL STEEL FRAMING

PART 1 GENERAL

1.01 SUMMARY

- A. Section Includes: All labor, materials, equipment and operations required to complete structural and miscellaneous metals in shapes and configurations indicated; including:
1. Structural steel columns, beams, bracing, base plates, bolts, joist hangers, and stud bolts welded to structural steel.
 2. Miscellaneous structural steel and connections; fabricated connectors and hangers installed by related sections.
 3. Anchor bolts and steel inserts embedded in concrete or masonry, installed by related sections.
 4. Fabricated steel items embedded in concrete or masonry installed by related sections.
 5. Supervision of anchor bolt setting, leveling and elevations to insure required fit of steel work.
 6. Shop priming and field touch-up, galvanizing.
 7. Bracing, Shoring, Fabrication and Erection.
- B. Related Sections:
1. Pertinent sections of Division 01 specifying Quality Control and Testing Agency services.
 2. Pertinent Sections of other Divisions specifying concrete reinforcement, formwork, concrete, structural and miscellaneous metal fabrications, steel joists, metal decking, cold-formed metal framing, rough carpentry.

1.02 REFERENCES

- A. California Code of Regulations, Title 24, latest adopted edition (herein noted as CBC): Chapter 22A Steel.
- B. American Institute of Steel Construction (AISC) 303 "Code of Standard Practice for Steel Buildings and Bridges".
- C. AISC 341 "Seismic Provisions for Structural Steel Buildings".
- D. AISC 358 "Prequalified Connection for Special and Intermediate Steel Moment Frames for Seismic Applications".
- E. AISC 360 "Specification for Structural Steel Buildings".
- F. American Welding Society (AWS) D1.1 "Structural Welding Code - Steel".
- G. AWS D1.8 "Structural Welding Code - Seismic Supplement".
- H. Research Council on Structural Connections (RCSC) "Specification for Structural Joints Using High-Strength Bolts".

- I. Underwriters Laboratories (UL) FRD "Fire Resistance Directory".

1.03 SUBMITTALS

- A. Submit in accordance with pertinent sections of Division 01 specifying submittal procedures. The General Contractor shall review and approve shop drawings prior to submittal to the Architect/Engineer. Submittals that do not meet these requirements will be returned for correction without review.
- B. Limitation of Review: Structural Engineer's review will be for general conformance with design intent as indicated in the Contract Documents and does not relieve Contractor of full responsibility for conformance with the Contract Documents.
- C. Product Data: Submit manufacturer's product data, specifications, location and installation instructions for proprietary materials and reinforcement accessories. Provide samples of these items upon request.
- D. Shop drawings: Submit each building as a complete unit. Do not mix components from multiple buildings or units of work in a submittal. Include all of the following;
1. Profiles, sizes, spacing, locations of structural members, openings, attachments, and fasteners.
 2. Fabrication tolerances for all steel.
 3. Connections: All, including type and location of shop and field connections.
 4. Indicate welded connections with AWS A2.4 welding symbols. Indicate net weld lengths, type, size, and sequence. Designate demand critical welds.
 5. Designation of Seismic Force Resisting System (SFRS) members and connections. Locate and dimension protected zones. Braced frame gusset plates shall be drawn to scale.
 6. Cross-reference all shop drawing detail references to contract document detail references.
 7. Secure all field measurements as necessary to complete this work prior to submitting shop drawings for review.
 8. Provide holes, welded studs, etc. as necessary to secure work of other sections.
 9. Provide the following as separate submittals for each building or unit of work:
 - a. Bolt and anchor setting plans.
 - b. Layout, fabrication and erection drawings.
- E. Certifications:
1. Steel Materials: Submit the following for identified materials.
 - a. Manufacturer's Mill Certificate: Certify that products meet or exceed specified requirements.
 - b. Mill Test Reports: Indicate structural strength, destructive test analysis, and non-destructive test analysis.
 - c. Contractor's affidavit certifying that all identified steel materials provided are of the grades specified and match the certificates supplied.
 2. High-Strength Bolting: Certify all materials provided are the grades specified.
 3. Welders Certificates: Certify welders employed on the Work, verifying AWS qualification per AWS D1.1.

- F. Samples: Provide samples to the Testing Agency as specified in Article SOURCE QUALITY CONTROL, at no additional costs.

1.04 QUALITY ASSURANCE

- A. Requirements of Regulatory Agencies, refer to pertinent sections of Division 01 and CBC Chapter 17A.
- B. All tests shall be performed by a recognized testing agency as specified in pertinent sections of Division 01.
- C. Certification and Identification of Materials and Uses: Provide Testing Agency with access to fabrication plant to facilitate inspection of steel. Provide notification of commencement and duration of shop fabrication in sufficient time to allow inspection and all material identification/test information listed below.
 - 1. Test all steel as required by ASTM A6.
 - 2. Provide manufacturer's Mill Test Reports for all materials. Include chemical and physical properties of the material for each heat number manufactured. Tag all fabricated materials with heat number.
 - 3. Provide letter certifying all materials supplied are from heat numbers covered by supplied mill certificates. Include in letter the physical location of each material type and/or heat number in the project (i.e. walls, braced frames etc.).
 - 4. Unidentified Material Tests: Where identification of materials by heat number or mill tests cannot be made, Owner's Testing Agency shall test unidentified materials.
 - 5. Provide all certification, verifications, and other test data required to substantiate specified material properties at no additional cost to the Owner.
- D. Testing and Inspection: Tests and Inspections performed by Independent Testing Agency are specified below in Articles SOURCE QUALITY CONTROL and FIELD QUALITY CONTROL. Duties and limitations of Independent Testing Agency, test costs and test reports in conformance with pertinent sections of Division 01.
- E. The following standards are the minimum level of quality required. Provide higher quality work as specifically indicated in the Contract Documents.
 - 1. Workmanship and details of structural steel work shall conform to the CBC and AISC 360.
 - 2. The quality of materials and the fabrication of all welded connections shall conform to AWS D1.1 and D1.8.
 - 3. Comply with Section 10 of AISC 303 for architecturally exposed structural steel.
- F. The Testing Agency will review all submittals and testing of materials.
- G. All re-inspections made necessary by non-conforming work shall be at the Contractor's expense.

1.05 DELIVERY, STORAGE AND HANDLING

- A. Deliver materials to project site in bundles marked with durable tags indicating heat number, mill, member size and length, proposed location in the structure and other information corresponding with markings shown on placement diagrams.

- B. Handle and store materials above ground to prevent damage, contamination or accumulation of dirt or rust.

1.06 SCHEDULING AND SEQUENCING

- A. Organize the work and employ shop and field crew(s) of sufficient size to minimize inspections by the Testing Agency.
- B. Provide schedule and sequence information to Testing Agency in writing upon request. Update information as work progresses.

PART 2 PRODUCTS

2.01 MATERIALS

- A. Structural Steel W Shapes: ASTM A992 Gr. 50 or ASTM A572 Gr. 50.
- B. Structural Steel Plates: ASTM A36 or ASTM A572 Gr. 50 or ASTM 529 Gr. 50
- C. Structural Steel Channels, Angles: ASTM A36 or ASTM A572 Gr. 50.
- D. HSS (Hollow Structural Sections):
 - 1. Round: ASTM A500, Gr. B.
 - 2. Rectangular or Square: ASTM A500, Gr. B.
- E. Pipe: ASTM A53, Grade B.
- F. Bolts and Washers: See FINISHES section for galvanization, where required.
 - 1. Machine Bolts, Nuts, and Washers: Bearing and shear connections (denoted as "MB"); ASTM A307 Grade A machine bolts with ASTM A563 Grade A nuts and ASTM F844 washers to match.
 - 2. High Strength Bolts, Nuts, and Washers: Bearing and shear connections (denoted as "HSB"); ASTM F3125 Grade A325 or A490 with ASTM A563 Grade C nuts (Grade DH at A490) and ASTM F436 Type 1 washers.
 - a. HSB-N: For use in a snug tight (ST) and pretensioned joints (PT) conforming to the RCSC Specifications.
 - b. HSB-X: For use in a slip critical (SC) connections conforming to the RCSC Specifications requiring a Type A faying surface (including coatings). All galvanized surfaces shall be Type C and hand wire brushed and roughened.
 - c. Use of ASTM F3125 Grade F1852 (twist off assemblies) is permitted conforming to requirements of RCSC Specifications.
 - d. Use of ASTM F959 Load Indicator Washers is permitted conforming to the requirements of RCSC Specifications.
- G. Headed Stud Type Shear Connectors: ASTM A108.
- H. Deformed Bar Anchors: ASTM A496.
- I. Anchor Bolts/Rods:

1. ASTM F1554 Grade 36 or 55 with ASTM A563 Grade A nuts and ASTM F436 Type 1 washers.
 2. ASTM F1554 Grade 105 where indicated on plans with ASTM A563 Grade DH nuts and ASTM F436 Type 1 washers.
 3. No upset thread allowed.
- J. Arc-Welding Electrodes: AWS Standards E70 or equivalent, except no E70T-4 allowed. Additionally, welding electrodes to be used in the welding of seismic force resisting system to conform to AISC 341 and AWS D1.8.
- K. Other Welding Materials: AWS D1.1; type required for materials being welded.

2.02 ACCESSORIES

- A. High Strength Grout: ASTM C1107, non-shrink, premixed compound consisting of aggregate, cement, and water reducing plasticizing agents.
1. Minimum Compressive Strength at 48 hours: 2400 psi.
 2. Minimum Compressive Strength at 28 days: 7000 psi, placed in a "fluid" state.
 3. Provide only non-metallic grout at exposed work.
 4. Meet or exceed properties of BASF "Master Flow 928" mixed to fluid consistency. Other acceptable manufacturers: The Burke Company and W.R. Meadows, Inc.
- B. Building Structural Steel Primers: Comply with local VOC limitations of authorities having jurisdiction and the California Green Building Code. Verify compatibility with finish coats specified in other sections. Follow manufacturers printed instructions. Apply one coat unless otherwise directed.
1. Type A: Self-Crosslinking Hydrophobic Acrylic passing 1942 hours ASTM D4585 & D1654. "Series 115 Uni-Bond DF" by Tnemec (2.0 to 4.0 mils DFT).
 2. Type B: Organic Zinc-Rich Urethane passing 10,000 hours ASTM B117 & G85. "Series 90-97/H90-97 Tneme-Zinc" by Tnemec (2.5 to 3.5 mils DFT) or "Series 94-H20 Hydro-Zinc" by Tnemec (2.5 to 3.5 mils DFT).
 3. Type C: MIO-Zinc Filled Urethane passing 10,000 hours ASTM B117. "Series 394 PerimePrime" by Tnemec (2.5 to 3.5 mils DFT).
- C. Galvanizing: ASTM A153 and A123.
- D. Touch-Up Primer for Galvanized Surfaces: Type B primer.

2.03 FABRICATION

- A. Shop fabricate to greatest extent possible.
- B. Continuously seal joined members by continuous welds. Grind welds smooth where exposed to view and where noted on drawings.
- C. Fabricate connections for bolt, nut, and washer connectors.
- D. Protect all materials, before and after fabrication, from rust, corrosion, dirt, grease, and other

foreign matter.

- E. Fabricate framing members free from twists or bends. Form holes, cut and sheared edges neatly without kinks, burrs, or warped edges.
- F. Exposed Steel: Straight, smooth, free of nicks, scars or dents.
- G. Gas Cutting: Gas cutting of holes in a member shall not be permitted.
- H. Splicing of members: Members requiring splicing due to length requirements may be spliced using full penetration butt welds when such welds and procedures are inspected and certified by the Testing Agency, in conformance with AWS and AISC standards. The location of splices shall be approved by the Architect/Engineer in writing prior to fabrication.
- I. Welding: Welding of structural steel connections shall be performed by qualified welders in accordance with AWS Standards. All weld sizes shall match those shown on the drawings.
 - 1. Preparation: Clean all surfaces free of rust, paint and all foreign matter. Remove paint or scale by brushing, chipping or hammering as required. Chip clean and wire brush burned or flame cut edges before welding. Space and alternate welds, clamping as necessary to prevent warp or misalignment.
 - 2. Sequence Welding: When welds enclose, or partially enclose, the perimeter or portion of the surface of a member, make weld bead in sequence, or staggered. Minimize internal stresses. Weld groups of members occurring in a single line in staggered sequence to minimize distortion of the structural frame.
 - 3. Faulty and Defective Welding: Welds failing to meet AWS standards and the Contract Documents shall be rejected and remade at Contractor expense. All welds showing cracks, slag inclusion, lack of fusion, bad undercut or other defects, ascertained by visual or other means of inspection shall be removed and replaced with conforming work.
 - 4. Minimum Weld Strengths: All welds shall match the minimum weld sizes recommended by AISC. Details of fabrication not specifically shown shall match similar details which are specifically shown. All bevel and groove welds shall be full penetration unless size is noted otherwise.
 - 5. Threaded studs, headed studs, and deformed bar anchors shall be full-fusion welded conforming to ASW D1.1.
- J. Camber: Fabricate all beams cambered as indicated on the drawings.
 - 1. Fabricate beams without camber for installation with any "natural" crown up.
 - 2. Exception: Fabricate cantilever beams with "crown" down.
- K. Grinding: Grind smooth the following structural steel and connections;
 - 1. Exposed cut ends of structural and fabricated shapes.
 - 2. All welds exposed to view.
 - 3. Mitered and fit-up corners and intersections.
- L. Back-Up Bars: Required for all complete penetration welds. See requirements of AISC 358.
- M. Bolt Holes: Edge, end distances and spacing shall conform to dimensions shown on the drawings, and as follows;

1. Round: Size indicated and 1/16 inch maximum oversize
2. Slotted: At locations specifically noted on the drawings, provide size indicated and 1/16 inch by 1/4 inch oversize slotted in direction perpendicular to applied loads.
3. Holes in base plates for anchor bolts may be 1/8 inch oversize.

2.04 FINISHES

- A. Steel exposed to inclement atmospheric conditions or weather (such as coastal moisture or seasonal rain) shall be sufficiently primed or otherwise protected against corrosion. If condition of steel is suspect due to weathering/corrosion, Contractor shall bear cost of inspection to determine if excessive corrosion is present and if steel member(s) requires repair or replacement. Contractor shall bear cost of repair or replacement.
- B. Prepare and finish structural and miscellaneous steel component surfaces as follows, unless a higher standard-of-care is determined necessary per item A:
 1. Unpainted, interior, dry exposure surfaces need not be primed.
 2. Finished painted, interior, dry exposure surfaces:
 - a. Surface Preparation: SSPC-SP2 Hand-Tool or SP3 Power-Tool Cleaning. Where jobsite exposure is expected to exceed 6 months, SSPC-SP6 Commercial Blast-Cleaning is required.
 - b. Apply Primer Type A. Field touchup with Type A or Type B.
 3. Finish painted surfaces with exterior exposure, interior exposure subject to wet conditions or fumes, finish painted surfaces with slip critical bolted connections, or surfaces to receive high performance finish coatings (for example epoxy or urethane for use at frequently abraded surfaces).
 - a. Surface Preparation: SSPC-SP6 Commercial Blast-Cleaning. For severe (immersion) exposure, SSPC-SP10 Near-White Blast-Cleaning is required.
 - b. Apply Primer Type B. Field touchup with Type B.
 4. Surfaces to be fire proofed need not be primed unless required by the fireproofing manufacturer or if jobsite exposure is expected to be inclement per item A. Where unprimed steel is to receive fireproofing, prepare steel surface as required by fireproofing manufacturer. If fireproofed surfaces are to be primed, provide primer as follows (note, slip critical bolted surfaces may be included):
 - a. Surface Preparation: SSPC-SP3 Power-Tool Cleaning.
 - b. Apply Primer Type C. Field touchup with Type C.
 5. Exterior exposed (unpainted) surfaces and as otherwise indicated to receive galvanizing:
 - a. Galvanize per ASTM A123 Class 55 minimum. Passivation agents are not permitted on galvanized metal that is to be painted. Provide vent holes per ASTM A385 at closed sections (such as HSS). Submit proposed location of vent holes for review by Engineer.
 - b. Connection hardware shall be hot-dip galvanized per ASTM A153 or F2329. Grade A325 high-strength bolt assemblies may be mechanically galvanized per ASTM B695 class 55 or hot-dip galvanized per ASTM F2329. Mating bolts and nuts shall receive the same zinc-coating process.
 - c. Repair all uncoated, damaged, or altered galvanized surfaces per ASTM A780.
- C. Do not prime the following surfaces unless otherwise indicated:
 1. Connections to be field welded.

2. Steel in contact with concrete.
 3. Surfaces to receive welded metal decking.
- D. Slip critical bolted connection surfaces shall either be unfinished & prepared per the RCSC or primed per item B3 or B4.
- E. Do not cover up work with finish materials until inspection is complete and work is approved by the Testing Agency.

2.05 SOURCE QUALITY CONTROL

- A. An independent Testing Agency will perform source quality control tests and submit reports, as specified in pertinent sections of Division 01.
- B. Steel Materials Testing:
1. No testing is required for materials identified in accordance with CBC Section 2203A.1 (heat number, grade stencil, etc.).
 2. Unidentified steel- General: Test all structural shapes. In addition, test to verify F_y and F_u values when engineering requirements exceed $F_y = 25$ ksi for design.
 3. Charpy V-Notch (CVN) testing requirements are per AISC 341. Heavy sections requiring CVN testing are indicated on the documents.
- C. Shop Welding Inspection:
1. Testing Agency shall inspect and certify all structural welds, unless the fabricating shop has been accredited in conformance with CBC requirements. Submit certification to the Architect/Engineer for review and the Building Official for approval.
 2. Welder Qualifications: Welding inspector shall verify that all the welders are properly qualified prior to steel fabrication and state the qualifications of each welder in the welding inspection report.
 3. Welding Inspection: Continuous inspection required unless otherwise noted below. Comply with requirements of AWS D1.1, AWS D1.8 and AISC 341.
 - a. Welding Inspector shall check all welds, materials, equipment and procedures.
 - b. Welding Inspector shall provide reports certifying the welding is as required and has been done in conformity with the plans, specifications and codes.
 - c. Welding Inspector shall use radiographic, ultrasonic, magnetic particle, or any other necessary aid to visual inspection to assure adequacy of welds. Ultrasonic Testing (UT) shall be required for all complete joint penetration (CJP) welds of material 5/16 inch thick or greater.
 4. Periodic Inspection Acceptable:
 - a. Single pass fillet welds not exceeding 5/16 inch.
 - b. Welding of studs to beams.
- D. Bolts, Nuts and Washers: Provide samples to Testing Agency for required testing, at no additional cost.
- E. High Strength Bolted Connections: Provide testing and verification of shop-bolted connections in accordance with RCSC specifications. Test all bolts at each connection.

PART 3 EXECUTION

3.01 EXAMINATION

- A. Verify that conditions are appropriate for erection of structural steel and that the work may properly proceed.

3.02 ERECTION

- A. Erect structural steel in compliance with AISC 303.
- B. Framing:
 - 1. Erect all structural steel true and plumb.
 - 2. Verify proper final alignment prior to making final connections.
- C. Field Connections:
 - 1. Workmanship of field bolted and welded connections shall conform in all respects to methods and tolerances specified for fabrication.
 - 2. Field weld components indicated on shop drawings. Sequence field welds to minimize built-up stress and distortion of the structural frame. Verify sequence with Engineer. Coordinate field welding schedule with Testing Laboratory.
 - 3. Welded Studs: Install in accordance with manufacturer's instructions and structural welding code AWS D1.1 and AWS D1.8.
- D. Templates: Provide bolt setting templates for all anchor bolts. Provide instructions for the setting of anchors and bearing plates, verify these items are set correctly as work progresses.
- E. Column base plates: Set level to correct elevations, support temporarily on steel wedges, shims, or leveling nuts where shown, until the supported members are plumbed and base plate is grouted.
 - 1. Grout solid the full bearing area under base plates prior to installation of floor and/or roof decks.
 - 2. Comply with manufacturer's instructions for high strength grout. Trowel grouted surfaces smooth, splaying neatly to 45 degrees.
- F. Bolting - General:
 - 1. Inspect mating surfaces to insure that bolt head and nut will have full bearing and that metal plies will mate flush between bolts.
 - 2. Install bolts in matching holes. Do not distort metal or enlarge holes by drifting during assembly. Remake mismatched components to achieve tolerances indicated.
 - 3. Holes mismatched in excess of 1/8 inch will be rejected.
 - 4. Holes mismatched less than 1/8 inch may be reamed to the next larger size bolt.
 - 5. Do not enlarge holes by flame cutting or air/arc ("plasma") cutting.
 - 6. Provide flat washer(s) at over-size holes.
 - 7. Provide washers for all conditions per RSCS Section 6 and under nuts to connected parts less than 1/4 inch thick.
 - 8. Provide ASTM F436 beveled washers when the slope of the surfaces of parts in contact with the bolt head or nut is greater than 1:20.

9. Do not install bolts with damaged threads.
10. Threads shall commence outside of the shear plane.

G. Bolting - Specific:

1. Machine Bolts (MB): Install and tighten to a snug condition (ST) such that laminated surfaces bear fully on one another, using an impact wrench or "full effort" of an installer using a standard spud wrench.
2. High Strength Bolts in Bearing/Shear or Static Tension joints snug tight (ST):
 - a. Provide a hardened washer at the head/nut at slotted holes
 - b. Install and tighten as per Machine Bolts (MB) snug tight (ST) and other requirements of RCSC specification Section 8.
 - c. Use ASTM F436 washer only in snug tight connections with static tension loads.
3. High Strength Bolts in Pretensioned joints (PT):
 - a. Provide ASTM F436 washer per requirements of RCSC Section 6.
 - b. Install and tighten in accordance with the requirements of RCSC Section 8.
 - c. Install bolts in all holes of the joint and compact the joint until the connected plies are in firm contact prior to pretensioning.
 - d. The following tightening methods and bolt type are acceptable for PT joints:
 - (a) Turn-of-the-nut pretensioning method
 - (b) Calibrated wrench pretensioning method
 - (c) Twist-off-type tension-control bolts
 - (d) Direct-tension-indicator washer pretensioning method.
4. High Strength Bolts in Slip Critical (SC) joints:
 - a. Provide tensioning for High Strength Bolts (PT) per above.
 - b. Faying surfaces to be prepared per RCSC Section 3 and PART 2.

H. Supports, Shoring and Bracing: Allow for erection loads and provide sufficient temporary bracing to maintain structure in safe condition, plumb, and in true alignment until completion of erection and installation of permanent bracing. Conform to requirements of all applicable laws and governing safety regulations. Resist imposed loads, including those of stored materials and equipment.

1. Provide all temporary supports, shoring and bracing necessary to achieve work of tolerances indicated.
2. Provide all necessary temporary flooring, planking and scaffolding required for erection of steel, and support of erection machinery.
3. Construction Loading: Do not overload the structure or temporary supports with stored materials, equipment or other loads.
4. Maintain temporary bracing and shoring until work is complete, and longer as required to ensure stability and safety of structure.

I. Do not make final connections until structure is aligned to meet specified tolerances.

3.03 ERECTION TOLERANCES

- A. Maximum Variation From Plumb: 1/4 inch per story, non-cumulative.
- B. Maximum Offset From True Alignment: 1/4 inch.

3.04 FIELD QUALITY CONTROL

- A. The independent Testing Agency will perform field quality control tests, as specified in pertinent sections of Division 01.
- B. Field Welding Inspection: Conform to all requirements of section SOURCE QUALITY CONTROL.
- C. High Strength Bolting: Provide testing and verification of field-bolted connections in accordance with RCSC Section 9.
 - 1. Inspect mating surfaces.
 - 2. Test all materials prior to use. Use only materials meeting specified requirements.
 - 3. Inspector shall review installation and verify "full effort" with installers for ST joints and shall randomly manually verify "full effort" on 10 percent of installed bolts.
 - 4. Inspector shall verify installation for 100% of SC and PT joints.
 - 5. Review installation procedures for all types of HSB joints and verify installation of "Twist-off" and load-indicator type bolts.
 - 6. If any bolt fails testing, all bolts at the joint shall be loosened and re-tightened. Exception: Galvanized bolts shall be replaced prior to re-testing.
- D. Welded Studs: Test headed studs electro-magnetically welded through metal deck to directly to steel members as follows:
 - 1. Install minimum of two trial studs.
 - 2. Testing Agency shall bend studs with a hammer to minimum 30 degrees out of axis.
 - 3. Any failure shall require new studs be welded for another test and welding apparatus adjusted.

3.05 ADJUSTING

- A. Touch-up damaged finishes with compatible specified primer.
- B. Replace defective or damaged work with conforming work. Replace all defective work at Contractor's expense.
- C. Straighten materials by means that will not injure the materials.
- D. Replace defective or damaged work which cannot be corrected in the field with new work, or return defective items to the shop for repair.
- E. Architect/Engineer shall review all proposals for the repair or replacement of damaged, defective, or missing work.
- F. Pay expenses incurred by Owner for Architect/Engineer's costs for (re-)design and obtaining approvals of Authorities Having Jurisdiction (AHJ) necessitated by incomplete, inefficiently scheduled, improperly performed, defective or nonconforming work, as specified in pertinent sections of Division 01.
- G. Pay expenses due to re-testing and re-inspection necessitated by incomplete, inefficiently scheduled, improperly performed, defective or nonconforming work, as specified in pertinent sections of Division 01.

3.06 CLEANING AND PROTECTION

- A. Clean all surfaces upon completion of erection; leave free of grime and dirt. Remove unused materials, tools, equipment and debris from the premises and leave surfaces broomed clean.
- B. Protect work from damage by subsequent operations.

END OF SECTION

SECTION 05 3000

METAL DECKING

PART 1 GENERAL

1.01 SUMMARY

- A. Section Includes: All material, labor, equipment and services necessary for the fabrication, erection, and completion of all metal decking as noted on drawings, including all supports for erection. The work shall include, but not necessarily be limited to the following:
1. Furnish metal decking, supports at structural steel, closures, flashing, weld plates, and necessary accessories, complete and ready to receive concrete or roofing.
 2. Install metal decking including cutting, fitting, and welding.
 3. All cutting and reinforcing of openings as required, and as laid out by other trades.
- B. Related Sections:
1. Pertinent Sections of Division 01 Specifying Quality Control and Testing Agency Services
 2. Pertinent Sections of Division 03 Specifying Concrete Construction
 3. Pertinent Sections of Division 05 Specifying Structural Steel

1.02 REFERENCES

- A. California Code of Regulations, Title 24, latest adopted edition (herein noted as CBC): Chapter 19A Concrete, Chapter 22A Steel.
- B. American Iron and Steel Institute (AISI) S100 "North American Specification for the Design of Cold-Formed Steel Structural Members".
- C. Steel Deck Institute (SDI) "Design Manual for Composite Decks, Form Decks and Roof Decks".
- D. International Code Council (ICC) "Acceptance Criteria (AC) 43 - Steel Deck Roof and Floor Systems".
- E. American Society for Testing and Materials (ASTM):
1. ASTM A653 "Standard Specification for Steel Sheet, Zinc-Coated (Galvanized) or Zinc-Iron Alloy-Coated (Galvannealed) by the Hot-Dip Process".
 2. ASTM A780 "Standard Practice for Repair of Damaged and Uncoated Areas of Hot-Dip Galvanized Coatings".
 3. ASTM A1003 "Standard Specification for Steel Sheet, Carbon, Metallic- and Nonmetallic-Coated for Cold-Formed Framing Members".
 4. ASTM A1008 "Standard Specification for Steel, Sheet, Cold-Rolled, Carbon, Structural, High-Strength Low-Alloy, High-Strength Low-Alloy with Improved Formability, Solution Hardened, and Bake Hardenable".
 5. ASTM C1513 "Standard Specification for Steel Tapping Screws for Cold-Formed Steel Framing Connections".
- F. American Welding Society (AWS) "D1.3 Structural Welding Code - Sheet Steel".

1.03 SUBMITTALS

- A. Shop drawings shall indicate all details of layout, fabrication and installation, location and dimension of openings, reinforcing and accessories, metal closures and flashing and type, size and location of all welds, and electromagnetically welded studs. Submit shop drawings before the start of fabrication. All details must reference detail callouts on the construction documents. Submittals that do not meet these requirements will be returned for correction without review.
- B. Current ICC reports indicating design values.
- C. Obtain reviewed structural steel shop drawings and verify all conditions before preparing shop drawings for metal decking; show all members required for support of metal decking on shop drawings for metal decking.
- D. The Contractor shall review and approve shop drawings prior to submittal. The Architect's review is of a general nature only and all responsibility for conformance with drawings and specifications and for dimensions shall remain with the Contractor.

1.04 QUALITY ASSURANCE

- A. All work under this section shall be fabricated and installed in strict accordance with the incorporated documents. Refer to pertinent sections of Division 05, Structural Steel.
- B. Decking shall be installed in the field by an approved steel deck applicator with at least five years demonstrated successful experience in this type work.
- C. All installation and welding shall be done by qualified, experienced workers skilled in their trade, in conformance with established standards of good practice and the manufacturer's recommendations. All welders shall be AWS certified.

1.05 DELIVERY, STORAGE AND HANDLING

- A. Protection: Steel decking sheets shall be covered and protected from weather during transit and during storage at the job site. Sheets shall not be in contact with the ground and are to have a waterproof covering.

1.06 JOB CONDITIONS

- A. Coordination: The Contractor shall secure all field measurements necessary for the completion of this work. The Contractor shall be responsible for all errors of detailing and fabrication and for the correct fitting of all metal decking to each other and to their supports. Provide holes and reinforcement for mechanical and electrical penetrations.

PART 2 PRODUCTS

2.01 MATERIALS

- A. Deck shall be of type and by manufacturer as specified on the drawings or approved equal. All equals must meet or exceed ICC approved design values of specified decking.

- B. Steel decking and flashing shall be formed from steel sheets conforming to ASTM A653, A1003, or A1008 with a minimum yield strength of 40,000 psi. Before forming, the steel shall receive a protective metal coating of zinc conforming to ASTM A653 G60 wiped coating.
- C. Deck Sections
 - 1. Deck units shall be supplied in lengths to span over at least 3 supports where layout permits. All single span units shall have temporary mid-span shoring.
 - 2. All deck units shall be provided with either an interlocking side lap or a lapping type side lap.
 - 3. Venting Devices: Unless noted otherwise, all deck sections to receive cementitious fill shall be vented using individual separating clips of type, style and spacing recommended by deck manufacturer (space no more than 48" o.c. or a two per deck span) or built-in venting-slot formed as an integral part of deck profile. Venting slots are required only in non-cellular deck. Tabs shall be turned up into deck so that they cannot be used for hangers. Provide three rows of slots at 2'-0" on centers in three foot wide deck sections.
 - 4. Flashing and Closure Plates: Provide 16 gauge zinc coated continuous flashing for deck units as detailed, or as required, at ends and sides, at openings and at deck perimeter to contain fill. Flashing shall be detailed and installed to prevent concrete leakage.
 - 5. Reinforcing at openings and penetrations: Provide reinforcing at all openings and penetrations per PART 3.
 - 6. Galvanization Coating Repair: Zinc dust-zinc oxide primer, ASTM A780.
- D. Headed welded studs and deformed bar anchors: See section 05 1200 or 05 1100.
- E. Painted Finish: Where painted finish is specified it shall be Manufacturer's standard; baked on, rust inhibitive, applied to chemically cleaned surface.
- F. Welding Electrodes: AWS Standard E60 or equivalent or E70 or equivalent, or as specified by AWS D1.3 and Manufacturer's recommendation.

2.02 FABRICATION

- A. All fabrication bevel cuts, etc. shall be done in the shop, and shall be equal to a high standard of workmanship. All deck units shall be shipped to the field in standard widths and in precut lengths so that end joints occur over supporting members.
- B. Deck section shall be cut to fit all openings, which are required. Dimensions of openings and holes required for the work of other trades will be provided by respective trades for cutting of deck.
- C. Misalignment of deck sections and cuts, short lengths, and poor workmanship shall be cause for rejection. All rejected work shall be replaced at the Contractor's expense.

2.03 SOURCE QUALITY CONTROL

- A. An independent testing agency will perform source quality control tests and submit reports as specified in pertinent sections of Division 01.
- B. Steel Materials Testing:
 - 1. No Testing Required for Materials as follows:

- a. Materials identified in accordance with CBC 2203A.1 and ASTM A6. (heat number, grade stencil, etc.)
 - b. Materials accompanied by certified mill test reports for all members, and Contractor's affidavit confirming that all materials used in the fabrication and shipped to the job are from the grades specified and match the certificates supplied.
2. Unidentified steel: Where identification of materials by heat number or mill reports cannot be made, testing agency shall test unidentified deck.

PART 3 EXECUTION

3.01 INSTALLATION

- A. The steel deck units shall be placed on the supporting framework, aligned, and adjusted to final position before being permanently fastened. Each unit shall be brought to proper bearing on the supporting beams. If the supporting beams are not properly aligned or sufficiently level to permit proper bearing of the steel units, the Contractor shall notify the Architect prior to taking corrective action to insure properly aligned work.
- B. Deck units shall be placed in straight alignment for the entire length of run with close registration of the cells of one unit with those of abutting and adjoining units. Provide a minimum of 2 inch end bearing at abutting deck units. Continuous deck units shall be provided with a minimum of 3" bearing, all butt joints shall be "tight" (no gap).
- C. Deck units shall not be placed on supporting members until all structural steel is completely installed, plumbed, and connections are completed.
- D. Welding:
 1. Steel deck units shall be fastened to the steel framework by the arc welding process. Welds shall be free of sharp points or edges.
 2. All welding shall be done by competent experienced welders, thoroughly familiar with the metal to be welded, and certified for welding of light gauge metal.
 3. Deck sheets shall be welded to the supporting member and to each other with welds as listed below unless otherwise noted on the drawings.
 - a. End and intermediate support perpendicular to deck flutes: 3/4" diameter spot weld at each flute.
 - b. Side joints between individual deck units with side interlock joint: 1-1/2" top or side seam weld at 12" on center. Button punch at 36" on center before welding to draw units together.
 - c. Side joints between individual deck units where concrete is placed on the metal deck is to be button punched at 36" on center.
 - d. Boundary deck units to parallel supports and interior deck units to parallel framing supports 3/4" diameter spot weld or 3/8" x 1-1/4" arc seam weld at 12" on center.
 4. Weld all closure angles and plates with 3/4" diameter spot weld or 3/8" x 1-1/4" arc seam welds at 18" apart.
 5. Headed welded studs and deformed bar anchors: See section 05 1200 or 05 1100.
- E. Screw Attachment: When called for on the drawings, painted roof deck is to be attached with galvanized #12 hex head metal screws with neoprene washers at flutes and at 24" on center at side laps and at 12" on center at perimeter side laps. Screws and metal washers shall be painted to match deck color where decking is a painted finish surface.

- F. Decking shall be installed in a continuous operation to avoid delays in the construction.
- G. Opening reinforcement shall be as detailed on the drawings. Cutting of holes other than those detailed on the drawings shall be done only as specifically approved by the Architect. Holes not shown on structural drawings shall be cut and reinforced in accordance with details on drawings. In general, reinforcing is not required for holes less than 4" in diameter. Holes at column penetrations shall be reinforced as any other hole. See details on drawings for other requirements.
- H. Leave slag in place at welds to be covered by concrete. Elsewhere, remove slag to bright metal and touch up all welds and field cut edges with galvanization repair primer.
- I. Field Finishing:
 - 1. Permanently exposed galvanized surfaces requiring welding shall be thoroughly cleaned by wire brushing after welding and then touched up with galvanization repair primer.
 - 2. After erection all damaged surfaces shall be primed.
 - 3. Painted deck shall be touched up with primer and matching paint.

3.02 FIELD QUALITY CONTROL

- A. Welding Inspection:
 - 1. Testing Agency shall inspect and certify all structural welds. Submit certification to the Architect/Engineer for review and the Building Official for approval.
 - 2. Welder Qualifications: Welding inspector shall verify that all the welders are properly qualified prior to steel fabrication and state the qualifications of each welder in the welding inspection report.
 - 3. Welding Inspection:
 - a. Welding Inspector shall check all welds, materials, equipment and procedures.
 - b. Welding Inspector shall provide reports certifying the welding is as required and has been done in conformity with the plans, specifications and codes.
 - c. Periodic inspection per CBC is acceptable.

3.03 DEFECTIVE WORK

- A. All work not in conformance with these specifications and/or generally accepted standards of the trade, will be deemed defective by the Architect and will be rejected. All work that is defective shall be corrected or replaced as directed by the Architect. Corrections redesign, and replacement of defective work shall be at Contractor's expense.

3.04 CLEANING

- A. After erection, all surfaces shall be cleaned and left free of all grime and dirt. Decking shall be cleaned with solvents, if necessary to provide a surface, which will readily bond with concrete fill and direct-to-steel fireproofing. Remove unused materials, tools, scaffolding and debris from the premises and leave the area broom clean.

END OF SECTION

SECTION 05 5000
METAL FABRICATIONS

PART 1 GENERAL

1.01 SECTION INCLUDES

- A. All miscellaneous metal fabrications not classified as structural steel.
- B. Iron and steel fabrications for wood or metal framing, including bracing.
- C. Inserts and anchorages: Furnish only, inserts and anchoring devices for installation of miscellaneous metal work. Provide setting drawings, templates, instructions and directions for installation of anchorage devices. Coordinate delivery with other work.
- D. Miscellaneous nonferrous metal items not specified under other sections.
- E. Fabrication and installation of metal work, including shop and field welding, drilling, cutting, connecting and shop painting.
- F. Miscellaneous shapes, plates, angles, clip angles, supports, bolts, and specialty iron and steel items indicated and as necessary to complete the work, including, but not limited to, the following:
 - 1. Metal handrails, railings, guardrails.
 - 2. Pipe sleeves.
 - 3. Miscellaneous sunshades, brackets, canopies.
 - 4. Steel pipe rain water leaders and brackets.
 - 5. Decorative grilles, trusses, and architectural features.

1.02 RELATED REQUIREMENTS

- A. Section 03 3000 - Cast-in-Place Concrete: Placement of metal fabrications in concrete.
- B. Division 06 Sections: Installation of anchorage and support items. Framing connectors for wood framing.
- C. Section 05 1200 - Structural Steel.
- D. Section 07 6200 - Sheet Metal Flashing and Trim
- E. Section 08 1100 - Steel Doors and Frames
- F. Section 08 3323 - Overhead Coiling Doors
- G. Section 08 7100 - Door Hardware
- H. Refer to pertinent sections of Division 09 for interior and exterior painting
- I. Other sections requiring metal fabrications or referencing this section for fabrication and installation.
- J. Pertinent Division 22, 23 and 26 sections: Sleeves and inserts for mechanical piping and ducts, and electrical conduit, bracing and support of mechanical and electrical equipment.
- K. Section 32 3113 - Chain Link Fences And Gates
- L. Section 32 3116 - Ornamental Steel Fences And Gates
- M. Pertinent sections of Division 33 specifying storm drain piping requiring connection to rain water leaders.

1.03 REFERENCE STANDARDS

- A. ASTM A36/A36M - Standard Specification for Carbon Structural Steel.

- B. ASTM A53/A53M - Standard Specification for Pipe, Steel, Black and Hot-Dipped, Zinc-Coated, Welded and Seamless.
- C. ASTM A123/A123M - Standard Specification for Zinc (Hot-Dip Galvanized) Coatings on Iron and Steel Products.
- D. ASTM A283/A283M - Standard Specification for Low and Intermediate Tensile Strength Carbon Steel Plates.
- E. ASTM A307 - Standard Specification for Carbon Steel Bolts, Studs, and Threaded Rod 60 000 PSI Tensile Strength.
- F. ASTM A500/A500M - Standard Specification for Cold-Formed Welded and Seamless Carbon Steel Structural Tubing in Rounds and Shapes.
- G. ASTM A653/A653M - Standard Specification for Steel Sheet, Zinc-Coated (Galvanized) or Zinc-Iron Alloy-Coated (Galvannealed) by the Hot-Dip Process.
- H. ASTM F3125/F3125M - Standard Specification for High Strength Structural Bolts, Steel and Alloy Steel, Heat Treated, 120 ksi (830 MPa) and 150 ksi (1040 MPa) Minimum Tensile Strength, Inch and Metric Dimensions.
- I. ASTM E 935 - Test Methods for Performance of Permanent Metal Railing Systems and Rails for Buildings.
- J. AHDGA - American Hot Dip Galvanizing Association.
- K. NAAMM MBG 531 - Metal Bar Grating Manual; The National Association of Architectural Metal Manufacturers; 2000 (ANSI/NAAMM MBG 531).
- L. AWS A2.4 - Standard Symbols for Welding, Brazing, and Nondestructive Examination.
- M. AWS D1.1/D1.1M - Structural Welding Code - Steel.
- N. SSPC-Paint 15 - Steel Joist Shop Primer/Metal Building Primer.
- O. SSPC-Paint 20 - Zinc-Rich Primers (Type I, "Inorganic," and Type II, "Organic").
- P. SSPC-SP 2 - Hand Tool Cleaning.
- Q. SSPC (PM2) - Painting Manual, Vol. 2, Systems and Specifications; Steel Structures Painting Council.

1.04 SUBMITTALS

- A. See Section 01 3300 - Submittals, for submittal procedures.
- B. Shop Drawings: Indicate profiles, sizes, connection attachments, reinforcing, anchorage, size and type of fasteners, and accessories. Include erection drawings, elevations, and details where applicable.
 - 1. Include details of cuts, connections, camber, holes, and other pertinent data.
 - 2. Indicate welded connections using standard AWS A2.4 welding symbols. Indicate net weld lengths, sizes and types.
- C. Product Data:
 - 1. Catalog cuts for all manufactured items demonstrating compliance with specified requirements.
 - 2. Structural steel primer paint.
- D. Welding procedures: For welding structural steel as required in accordance with AWS D1.1, submit prequalified joints.
- E. Certification: Copy of approved fabricator's license.

- F. Manufacturer's data: Submit certified copies of the following prior to any fabrication. Include laboratory test reports and other data as required to show compliance with these specifications, including specified standards.
 - 1. Structural steel, including certified copies of mill reports covering the chemical and physical properties.
 - 2. Unfinished bolts and nuts.

1.05 SUBMITTALS FOR RECORD

- A. Section 01 3300 - Submittals: Procedures for submittals. Architect will not review these submittals.
- B. Welders' Certificates: Submit certification for welders employed on the project, verifying AWS qualification within the previous 12 months.

1.06 QUALITY ASSURANCE

- A. Design criteria: Design, fabricate and erect miscellaneous metal items complete, in accord with AISC's Design, Fabrication and Erection of Structural Steel for Buildings.
- B. Coordinate the Work under provisions of pertinent sections of Division 01.
- C. Welders:
 - 1. Qualify welding processes and welding operators in accordance with AWS "Standard Qualification Procedure".
 - 2. Provide certification that welders to be employed in the work have satisfactorily passed AWS qualification tests within the previous 12 months, and are qualified in the State of California.
- D. Welding Inspection: All structural welding shall be specially inspected according to CBC 1704A and DSA IR-17-3 except as otherwise provided below.
 - 1. Special inspection shall not be required if welding is done in an approved fabricator's shop licensed in accordance with CBC 1704A.

1.07 PRODUCT HANDLING

- A. Comply with pertinent provisions of Section 01 6000.
- B. Deliver anchor bolts, anchorage devices, sleeves and inserts, which are to be incorporated into other work in ample time to avoid delay.
- C. Store materials to permit easy access for inspection and identification. Store steel materials off the ground, using pallets, platforms or other supports. Protect steel members, package materials and identifications from deterioration.
- D. Store material to prevent twisting, bending, or abrasion, and to provide ventilation. Slope metal sheets to ensure drainage.
- E. Prevent contact with materials which may cause discoloration or staining. Clean materials which are discolored or stained.
- F. Replacements: In the event of damage, immediately make repairs and replacements necessary to the approval of the Architect and Division of the State Architect without change in contract amount or time.

PART 2 PRODUCTS

2.01 MATERIALS

- A. General: Furnish new tested stock complying with reference specifications.
- B. Steel Sections: ASTM A36/A36M.

- C. Steel Tubing: Hot formed, welded or seamless, ASTM A 501, or cold-formed, ASTM A500, Grade B cold-formed.
- D. Plates: ASTM A283/A283M.
- E. Pipe: ASTM A53/A53M, Grade B Schedule 40, black and hot-dip galvanized finish, as indicated.
- F. Slotted Channel Framing: ASTM A653/A653M, Grade 33.
- G. Slotted Channel Fittings: ASTM A1011/A1011M.
- H. Bars and bar-size shapes: ASTM A 663, Grade 65, or ASTM A 36.
- I. Sheets: ASTM A 446 with zinc-coating in accord with ASTM A 525, G-90.
- J. Hot-rolled carbon steel bars and bar-size shapes: ASTM A 575, Grade as selected by fabricator.
- K. Steel plate, checkered pattern: Steel with checkered (diamond) pattern, galvanized, ASTM A 525, coating designation G90.
- L. Carbon steel sheets and strips:
 - 1. Hot-rolled: ASTM A 568 and ASTM A 569, pickled and oiled.
 - 2. Cold-rolled: ASTM A 366.
 - 3. Galvanized sheets: ASTM A 525, or A 526 with G-90 zinc coating
- M. Toggle bolts: Tumble-wing type, FS FF-B-588, type, class and style as required.
- N. Fasteners: Select fasteners for type, grade and class required for the installation of miscellaneous metal items, compatible for material in contact. Provide hot-dipped galvanized at exterior exposures or when in contact with pressure-treated wood materials..
- O. Bolts, Nuts, and Washers: ASTM F3125/F3125M, Type 1, plain.
 - 1. Standard bolts and nuts: Regular square or hexagon head type, ASTM A 307, Grade A.
 - 2. Lag bolts: Square head type, galvanized.
 - 3. Machine screws: Cadmium-plated steel, ASTM F 468 and FS FF-S-92.
 - 4. Plain washers: ANSI B18.22.1 and FS FF-W-92.
 - 5. Anchors: Manufactured by Ramset Fastening System Division, Olin Corp., Rawlplug Co., Diamond Division, General Cable, Hilti or ITT Phillips Drill Division. Provide type best suited for intended application and indicate on shop drawings.
 - 6. Lock washers: FS FF-W-84, helical spring type carbon steel.
 - 7. Anchor Bolts: ASTM A307.
- P. Brackets, flanges and anchors: Cast or formed metal of the same type material and finish as supported rails, unless otherwise indicated.
- Q. Concrete inserts: Threaded or wedge type, galvanized ferrous castings, either malleable iron ASTM A 47 or cast steel ASTM A 27. Provide bolts, washers and shims as required, hot-dip galvanized, ASTM A 153.
- R. Welding Materials: AWS D1.1; type required for materials being welded. Comply with AWS D1.1, D1.3 and CBC Title 24 Part 2.
- S. Non-shrink Grout for Guardrail post inserts: Masterflow 928 Grout by Master Builders or equal.
- T. Zinc-rich paint (cold galvanizing): ZRC-221 by ZRC WorldWide, or equal.
- U. Shop and Touch-Up Primer: SSPC-Paint 15, complying with VOC limitations of authorities having jurisdiction, compatible with intermediate and finish coatings specified in other Sections.

- V. Touch-Up Primer for Galvanized Surfaces: ZRC Zero-VOC by ZRC Worldwide, or equal, compatible with intermediate and finish coatings specified in other Sections

2.02 FABRICATION

- A. Field Measurements: Take field measurements prior to preparation of shop drawings and fabrication, where possible, to ensure proper fitting of the work. Allow for trimming and fitting where field conditions preclude accurate measurements or where final dimensions cannot be established prior to fabrication.
- B. Fit and shop assemble items in largest practical sections, for delivery to site.
1. Minimize field splicing and site assembly. Disassemble only to the extent necessary for shipping and handling limitations. Clearly mark units for reassembly and coordinated installation.
 2. Complete assembly, including welding, before start of finishing operations. Provide finish surfaces of members exposed in the final structure free of markings, burrs, and other defects.
 3. Use materials and items necessary to complete the work, using the best materials and methods ordinarily used for this type of work whether explicitly specified, indicated and detailed or not.
- C. Fabricate items with joints tightly fitted and secured.
- D. Machine-roll components or elements required to be curved or radiused. Do not field bend or "walk-down". Provide curves true to indicated dimensions, minimizing joints; segmented fabrication not allowed unless specifically noted.
- E. Continuously seal joined members by continuous welds.
1. Grind exposed joints flush and smooth with adjacent finish surface. Make exposed joints butt tight, flush, and hairline. Ease exposed edges to small uniform radius.
 2. Exposed Mechanical Fastenings: Flush countersunk screws or bolts; unobtrusively located; consistent with design of component, except where specifically noted otherwise.
 3. Supply components required for anchorage of fabrications. Fabricate anchors and related components of same material and finish as fabrication, except where specifically noted otherwise.
- F. Use only materials smooth and free of blemishes including pitting, seam marks, roller marks, trade names and roughness.
- G. Fabricate steel members in accordance with drawings and as recommended by A.I.S.C. Verify all dimensions with field conditions prior to fabrication.
1. Clean, prepare and shop-prime steel members. Do not prime surfaces to be field welded or in direct contact with concrete.
 2. Galvanizing: ASTM A153, ASTM A123; all steel exposed to weather.
 3. Cutting and drilling: Provide holes for fabrication and for attachment of work specified elsewhere. Countersink holes for bolts and screws.
- H. Welding: Comply with the AWS Structural Welding Code, and with the following:
1. Welds shall be free from excessive oxides, nonmetallic inclusions, and gas pockets.
 2. Welds shall be uniform in section, smooth in weld metal, feather edged, without overlaps.
 3. Surfaces to be welded shall be free from loose scale, rust, paint, or other foreign matter.
 4. Tack welds located in way of design welds shall be melted out when encountered in final welding, or shall be thoroughly fused in with final weld.
 5. Use proper care and procedures to minimize locked-in stress and distortion.
 6. Welder qualification requirements, welding procedure and welding electrodes shall conform to CBC 2204A and most recent editions of AWS D1.1, D1.3; CBC IR-17-3.

2.03 METAL FENCES, HANDRAILS, and RAILINGS

- A. Steel pipe or tube fences,, handrails, and railings: Fabricate to dimensions and details shown, with welded joints ground smooth and flush. Hot-dipped galvanized at exterior locations.
 - 1. Fabricate and install to comply with requirements of ASTM E985 for structural performance based on testing performed in accordance with ASTM E894 and E935.
 - 2. Structural Performance: Handrails and top rails shall withstand the following structural loads:
 - a. Concentrated Load: 200 lbs., applied non-concurrently, in any direction.
 - b. Uniform Load:50 lb/ft. applied simultaneously in both vertical and horizontal direction.
 - c. Concentrated loads and uniform loads need not be assumed to act concurrently.
 - 3. Picket and grille spacing, fences adjacent to Playground areas: Fabricate fence pickets and grillework so that all openings in the finished fence are less than 3.5 inches or greater than 9 inches, including the opening between the bottom rail and the finish grade.
 - 4. Shop fabricate to greatest extent possible.
 - 5. Interconnect railing members by butt-welding or by welding with internal connectors, unless otherwise indicated.
 - 6. At tee and cross intersections, notch ends of intersection members to fit contour of pipe and weld all around.
 - 7. Form changes in direction of railing members by radius bends, maintaining cylindrical cross-section of pipe throughout bend without buckling, twisting, cracking or otherwise deforming exposed surface of pipe.
 - 8. Provide galvanized inserts for concrete paving for attachment of rails, where occurs.

2.04 STEEL PIPE RAIN WATER LEADERS (RWL)

- A. Steel pipe or tube rain water leaders: Fabricate to dimensions and details shown, with welded joints ground smooth and flush, hot-dipped galvanized.
 - 1. Structural Performance: Rain water leaders shall withstand the following structural loads:
 - a. Concentrated Load: 200 lbs., applied non-concurrently, in any direction.
 - b. Uniform Load:50 lb/ft. applied simultaneously in both vertical and horizontal direction.
 - c. Concentrated loads and uniform loads need not be assumed to act concurrently.
 - 2. Shop fabricate to greatest extent possible.
 - 3. Interconnect rainwater leader members by butt-welding or by welding with internal connectors, unless otherwise indicated.
 - 4. At intersections and changes of direction, notch ends of intersection members to fit contour of pipe and weld all around. Seal weld all joints water-tight.
 - 5. Form changes in direction of water flow by mitered connections, maintaining cylindrical cross-section of pipe throughout bend without buckling, twisting, cracking or otherwise deforming exposed surface of pipe.
 - 6. Provide support brackets of sizes and types indicated and with configurations required to suit substrates and framing spacing.

2.05 FINISHES - STEEL

- A. Hot-dip galvanize steel items fully or partially exposed to exterior conditions or to wet environments such as locker rooms, food service, custodial or toilet rooms. Prime paint steel items in all other locations.
 - 1. Exceptions: Galvanize items to be embedded in concrete or masonry.
 - 2. Exceptions: Do not prime surfaces in direct contact with concrete, where field welding is required, and items to be covered with sprayed fireproofing.
- B. Prepare surfaces to be primed in accordance with SSPC-SP2 SSPC SP-3, "Power Tool Cleaning", minimum. Remove oil, grease and similar contaminants in accordance with SSPC SP-1 "Solvent Cleaning".

1. Review coating systems specified in other Sections. Provide level of substrate surface finish required or recommended by coating manufacturer for each specified system.
- C. Prime Painting: One coat, primer in accordance with the coating manufacturer's printed instructions. Select products compatible with coating systems specified in other Sections.
- D. Galvanizing of Non-structural Items: Galvanize after fabrication to ASTM A123/A123M requirements.

2.06 FABRICATION TOLERANCES

- A. Squareness: 1/8 inch maximum difference in diagonal measurements.
- B. Maximum Offset Between Faces: 1/16 inch.
- C. Maximum Misalignment of Adjacent Members: 1/16 inch.
- D. Maximum Bow: 1/8 inch in 48 inches.
- E. Maximum Deviation From Plane: 1/16 inch in 48 inches.

PART 3 EXECUTION

3.01 EXAMINATION

- A. Verify that field conditions are acceptable and are ready to receive work. Correct conditions detrimental to the proper and timely performance of this work before proceeding with installation. Commencement of work indicates acceptance of substrates.

3.02 PREPARATION

- A. Clean and strip primed steel items to bare metal where site welding is required.
- B. Supply setting templates to the appropriate entities for steel items required to be cast into concrete or embedded in masonry.

3.03 INSTALLATION

- A. Install items plumb and level, measured from established lines and levels, accurately fitted, free from distortion or defects.
- B. Provide temporary bracing or anchors in formwork for items which are to be built into concrete or similar construction.
- C. Provide for erection loads, and for sufficient temporary bracing to maintain true alignment until completion of erection and installation of permanent attachments.
- D. Fastening to In-Place Construction: Provide anchorage devices and fasteners where necessary for securing miscellaneous metal items to in-place construction; including threaded fasteners for concrete inserts, toggle bolts, through-bolts, lag bolts, wood screws, and other connectors as required.
- E. Cutting and fitting:
 1. Perform cutting, drilling and fitting required for installation of miscellaneous metal items. Fit exposed connections accurately together to form tight hairline joints.
 2. Weld connections which are not to be left as exposed joints, but cannot be shop welded because of shipping size limitations.
 3. Do not weld, cut or abrade the surfaces of exterior units which have been hot dip galvanized after fabrication, and are intended for bolted or screwed field connections.

- F. Field weld components as indicated on drawings or as required to assemble shop-fabricated work on site. If field-welding is not specifically indicated on drawings, option is the Contractor's for efficient assembly.
- G. Perform field welding in accordance with AWS D1.1/D1.1M.
- H. Obtain approval prior to site cutting or making adjustments not scheduled.
- I. Immediately after erection, clean and prime welds, abrasions, and surfaces not shop primed or galvanized, except surfaces to be in contact with concrete with the same materials used for shop finishing.
- J. Rainwater Leader Installation: Plumb units in each direction.
 - 1. Accurately locate rainwater leaders in proximity to underground storm drain connections. Coordinate with work of other sections for accurate placement and alignment of the work.
 - 2. Secure Rainwater Leaders to walls using wall brackets. Secure brackets and return fittings as follows:
 - a. Wood framing: Stainless steel lag screws.
 - b. Steel Framing: Stainless steel threaded self- tapping screws.
 - c. Masonry or Concrete: Stainless steel threaded tap-in anchor bolts.
 - d. Structural Steel column or member: Weld.
 - 3. Locate supporting brackets at approximately equal intervals, not less than 5'-4" on center, not less than 18 inches from ends, with a minimum of three per supports per unit, and additional brackets within 18 inches of change in direction or substrate mounting material.
 - 4. Connect rain water leaders to storm drains with water-tight connection.

3.04 TOLERANCES

- A. Maximum Variation From Plumb: 1/4 inch per story, non-cumulative.
- B. Maximum Offset From True Alignment: 1/4 inch.
- C. Maximum Out-of-Position: 1/4 inch.

3.05 PROTECTION

- A. Protect finished work from damage until acceptance by Owner.
- B. Repair and replacement: In the event of damage, immediately make repairs and replacements necessary to satisfaction of Architect without change in contract sum or time.

3.06 CLEAN-UP

- A. When work of this section has been completed, and at such other times as may be directed, remove all trash, debris, surplus materials, tools and equipment from site.
- B. Comply with pertinent requirements of Division 01 section specifying Contract Closeout.

END OF SECTION

SECTION 06 1000

ROUGH CARPENTRY

PART 1 GENERAL

1.01 SUMMARY

- A. Section Includes: All labor, materials and equipment and all operations required to complete all rough carpentry and structural framing as indicated on the drawings; to produce shapes and configurations as shown, as required; and as specified herein, including:
1. Structural floor, wall, and roof framing.
 2. Floor, wall, and roof sheathing.
 3. Rough hardware, framing connectors and fasteners.
 4. Treatment of wood.
 5. Concealed wood blocking for support of toilet and bath accessories, wall cabinets, wood trim, and other work requiring supporting blocking.
 6. Miscellaneous wood nailers and furring strips, including roof applications, other wood framing, furring, shims or blocking as required to complete the work.
- B. Related Sections:
1. Pertinent sections of Division 01 specifying Quality Control and Testing Agency services.
 2. Pertinent sections of Division 01 specifying Structural Product Requirements: Structural Product Options, Substitution procedures and limitations, transportation, handling and storage.
 3. Pertinent sections of Division 03 specifying wood formwork construction and/or setting anchors in concrete.
 4. Pertinent section of Division 06 specifying wood construction and materials.
 5. Pertinent sections of other divisions specifying steel or concrete construction.

1.02 REFERENCES

- A. California Code of Regulations, Title 24, latest adopted edition (herein noted as CBC): Chapter 23 Wood.
- B. American National Standards Institute (ANSI) / American Wood Council (AWC) "NDS - National Design Specification for Wood Construction".
- C. National Institute of Standards and Technology (NIST) / Engineered Wood Association (APA) "PS 1 - Voluntary Product Standard for Structural Plywood".
- D. NIST / APA "PS 2 - Performance Standard for Wood-Based Structural-Use Panels".
- E. NIST "PS 20 - American Softwood Lumber Standard".
- F. Redwood Inspection Bureau (RIS) "Standard Specifications for Grades of California Redwood Lumber".

- G. West Coast Lumber Inspection Bureau (WCLIB) "Standard Grading Rules for West Coast Lumber No. 17".
- H. Western Wood Products Association (WWPA) "Western Lumber Grading Rules".
- I. American Wood Preservers Association (AWPA) "Book of Standards".

1.03 SUBMITTALS

- A. Submit in accordance with pertinent sections of Division 01 specifying submittal procedures. Submit for review prior to fabrication. Submittals that do not meet these requirements will be returned for correction without review.
 - 1. Substitutions for products specified require conformance to substitution requirements in Division 01.
 - 2. Review of materials and hardware for substitution to products specified is at the additional expense of the Contractor.
- B. Limitation of Review: Structural Engineer's review will be for general conformance with design intent as indicated in the Contract Documents and does not relieve Contractor of full responsibility for conformance with the Contract Documents. The General Contractor shall review and approve shop drawings prior to submittal to the Architect/Engineer.
- C. Product Data:
 - 1. Submit manufacturer's product data, specifications, and installation instructions for & location of framing connectors, wood preservative materials, application instructions, and fasteners. Include complete, accurate equivalence data when submitting alternate products to those specified. Provide samples of these items upon request.
 - 2. Submit product data and current ICC-ES report for machine-driven nails, fasteners, and equipment, including dimensions of all fasteners, including head, shank diameter and length.
 - 3. Submit samples of each and every type and size of proposed machine-driven nails and fasteners.
- D. Shop drawings: For manufactured wood products, submit each building as a complete unit. Do not mix components from multiple buildings or units of work in a submittal. Include all of the following;
 - 1. Indicate profiles, sizes, and spacing locations of structural members.
 - 2. Cross-reference all shop drawing detail references to contract document detail references.
 - 3. Secure all field measurements as necessary to complete this work.
- E. Manufacturer's Certificate: Submit all certifications of physical and chemical properties of materials as specified below in Article titled QUALITY ASSURANCE.
 - 1. Certify that wood products supplied for rough carpentry meet or exceed specified requirements, including specified moisture content.

1.04 QUALITY ASSURANCE

- A. Requirements of Regulatory Agencies, refer to pertinent sections of Division 01 and CBC Chapter 17A.
- B. All tests shall be performed by a recognized testing agency as specified in pertinent sections of Division 01.
- C. Inspection of fabricators is required per CBC 1704A.2 unless fabricator is registered and approved by the building official. Wood product quality standards:
 - 1. All wood products to comply with article REFERENCES.
 - 2. Factory-mark each piece of lumber and sheathing with type, grade, mill, and grading agency, except omit marking from surfaces to be exposed with transparent finish or without finish.
 - 3. Sheathing panels to be marked by APA (The Engineered Wood Association).
- D. End-Jointed lumber shall not be used.
- E. Hardware and engineered wood products shall have current ICC ES Evaluation/research reports that are equivalent to products specified.
- F. Employ competent workers experienced in work of the types specified and required.

1.05 MOCK-UP

- A. Construct mock-ups of machine-driven nailed sheathing panels using submitted products and demonstrating conditions indicated. Locate where directed.
- B. Mock-up shall be accepted and approved by the Inspector of Record (IOR) before commencement of machine-driven nailing activity.
- C. Accepted mock-up shall remain exposed for reference for the duration of machine-driven nailing activity.
- D. Remove all mock-ups at the completion of the work.

1.06 DELIVERY, STORAGE AND HANDLING

- A. Comply with pertinent requirements of Division 01.
- B. Delivery: Time delivery and installation of carpentry products to avoid delaying other trades whose work is dependent on or affected by this section and to comply with moisture content, protection and storage requirements.
- C. Keep materials dry at all times. Protect against exposure to weather and contact with damp or wet surfaces. Stack lumber and sheathing panels to prevent deformation and provide air circulation within stacks.

1. Store materials for which a maximum moisture content is specified only in areas where relative humidity has been reduced to a level where specified moisture content can be maintained.
2. Handle and store materials above ground to prevent damage, contamination, or accumulation of dirt or foreign materials.
3. Provide special protection for horizontal sheathing panels. Deformation of panels due to moisture is not acceptable.

1.07 PROJECT/SITE CONDITIONS

- A. Verify all conditions at project site affecting the work; work to field dimensions as required. Coordinate carpentry installation with size, location, and installation of service utilities.
- B. Sequence rough carpentry installation activities to allow sufficient time for:
 1. Review of all submittals, including machine-driven nail sample submittals.
 2. Fabrication of mock-ups and required durations as specified.
 3. Indicate submittal review, procurement, mock-up, and testing activities in the project schedule prior to the start of installation. Installation durations shall be based on hand-nailed installation methods specified.
 4. Attainment of specified maximum lumber moisture content.

PART 2 PRODUCTS

2.01 DIMENSIONED LUMBER

- A. General
 1. Size per industry standards for nominal sizes shown; S4S (sanded four sides).
 2. Warped/twisted and excessively checked members shall not be used regardless of grade marks.
 3. At the Contractor's option, engineered lumber of equivalent size and material properties may be substituted for solid sawn lumber where material is difficult to source due to length, availability, etc. Submit proposed substitution to Engineer for review prior to purchasing materials.
- B. Moisture content of framing:
 1. All lumber to be maximum 19% at time of fastener installation, except 3x and 4x studs may be 25% at time of sheathing panel nailing. All lumber to be maximum 19% at time of close-in, unless noted otherwise.
 2. The Owner's Testing Laboratory will test for moisture content prior to commencement of close-in.
 3. The Contractor shall recognize that excessive shrinkage of lumber results from excess moisture content at the time of installation. The Contractor will compensate for use of such lumber by waiting for acceptable moisture content before close in and/or by replacing/repairing lumber that has sagged, twisted, or warped prior to close in.
 4. Deviation from this specification would require structural redesign of connections and fasteners.

- C. Sills on concrete or masonry: No. 2 pressure treated Douglas Fir and as called for on the drawings.
- D. Interior structural framing shall be Douglas Fir (D.F.) with grades as noted below, unless otherwise specified on the drawings. All grades are per WCLIB standard grading rules.
 - 1. All permanently exposed (interior or protected from weather) framing shall be select structural grade with no box heart.
 - 2. Except per 1 above, unless noted otherwise, minimum grades are:
 - a. Floor/roof joists/rafters (2x) and 2x8 & larger studs: D.F. No. 1
 - b. 2x4 and 2x6 studs and plates: D.F. No. 2
 - c. 4x and larger: D.F. No. 1
 - d. Blocking: D.F. No. 2
 - e. 6x8 and larger posts and beams may be SGL/CGL per below unless noted otherwise on the drawings.
- E. Exterior structural framing (exposed to weather) shall be redwood select structural grade or pressure treated D.F. No. 1, unless noted otherwise.
- F. Structural decking shall be D.F. select decking or White Pine select where not exposed to moisture. Where directly exposed to moisture or high humidity for prolonged periods of time, decking shall be Alaskan Yellow Cedar or Port Orford Cedar. Moisture content at time of installation to be less than 12%.
- G. Framing not otherwise shown or specified: Douglas Fir construction grade per WCLIB paragraphs applicable to uses and sizes required.

2.02 MANUFACTURED LUMBER

- A. Structural (Certified) Glued Lumber (SGL): SGL shall be manufactured following the American Lumber Standards Committee (ALSC) "Glued Lumber Policy" and meet the requirements of Voluntary Product Standard PS 20 "American Softwood Lumber Standard". Grading shall be per the West Coast Lumber Inspection Bureau (WCLIB) or Western Wood Products Association (WWPA). SGL shall be manufactured with waterproof adhesive. "Stud use only" SGL is not permitted.
 - 1. Acceptable products:
 - a. "RMT" by Rosboro.
 - b. Approved equal.
 - 2. Where specified for use on plan, SGL shall be entirely Douglas Fir lumber. SGL shall be grademarked to match the grade as would be specified for solid sawn lumber in the same location/use.
 - 3. At the contractor's option, SGL may be substituted for solid sawn lumber. SGL species and grade shall match that for the solid sawn member. SGL shall not be substituted for glued-laminated (glulam) members.
- B. Laminated Veneer Lumber (LVL): for use as joists, beams, blocking, or studs when so noted on the drawings. Conform to ICC AC 47. Minimum $F_b = 2,600$ PSI. Minimum $E=1,900,000$ PSI.
Acceptable products:

1. "Microllam LVL" by Trus Joist, ICC ESR-1387
 2. "Redlam LVL" by RedBuilt, ICC ESR-2993
 3. Approved equal
- C. Laminated Strand Lumber (LSL): for use as blocking (flat or vertical) or rim joist when used with I-joist or LVL, when so noted on the drawings. Conform to ICC AC 124. Minimum $F_b = 1,700$ PSI. Minimum $E = 1,300,000$ PSI. Acceptable products:
1. "Timberstrand LSL" by Trus Joist, ICC ESR-1387
 2. Approved equal
- D. Parallel Strand Lumber (PSL): for use as beams and posts when so noted on the drawings. Conform to ICC AC 47. Minimum material properties for beams: $E = 2,000,000$ psi; $F_b = 2,900$ psi; $F_c = 2,900$ psi (parallel); $F_v = 290$ psi. Minimum material properties for posts: $E = 1,800,000$ psi; $F_b = 2,400$ psi; $F_c = 2,500$ psi (parallel); $F_v = 190$ psi. Acceptable products:
1. "Parallam PSL" by Trus Joist, ICC ESR-1387
 2. Approved equal

2.03 MANUFACTURED STRUCTURAL PANELS

- A. Plywood: Structural sheathing shall conform to product standard PS-1 or PS-2. All panels shall have an exterior exposure rating and bear the trademark of the Engineering Wood Association (APA) or other qualified agency. Grades shall be as required on the drawings.
- B. Oriented Strand Board (OSB): All structural OSB shall be grade marked by a qualified agency for conformance with Product Standard PS-2 and shall be fabricated with exterior glue. Grades shall be as required on the drawings.

2.04 TREATED WOOD:

- A. Treated Lumber and Plywood: Comply with requirements of AWPA Standard U1. See Standard U1 for "Use Category" designations. Do not provide higher Use Category lumber than that specified. Maximum moisture content shall be the same as required for "dimensioned lumber" as specified above.
- B. Preservative Treated Lumber
 1. General
 - a. Preservatives shall be waterborne. Preservative retention rate shall be as required per AWPA Standards U1 & T1. Lumber shall be Douglas Fir No. 2 (or better). Cut faces of treated wood shall be brush treated (two complete applications) prior to installation.
 - b. Lumber less than 8 inches above grade and lumber less than 6 inches above exterior hard-surface flatwork shall be treated.
 - c. Each piece of wood shall be stamped by the wood preservative applicator to identify its treatment and preservative retention.
 2. Lumber at interior, non-weather exposed locations installed adjacent to concrete or masonry shall be Use Category UC2. Examples include sill plates & ledgers and lumber in contact with roofing, flashing, or water proofing.

3. Lumber at exterior locations, not in contact with soil/ground, shall be Use Category UC3B. Examples include Douglas Fir decking and deck framing.
 4. Lumber in contact with soil/ground shall be Use Category UC4A. Examples include timber retaining walls.
 5. Poles, posts, and sheathing panels shall be treated as recommended by AWPA Standard U1 per use and exposure.
 6. Maximum Volatile Organic Compound (VOC) content of field-applied preservative shall meet local air quality standards and the California Green Building Code. Provide either of the following:
 - a. Copper Azole (CA-B) per ICC-ES AC143.
 - b. Alkaline/Copper/Quaternary (ACQ).
- C. Fire Retardant Treatment: Product and application process must be recommended by manufacturer of treatment as being suitable for painting. Application shall be by a California State Fire Marshal approved licensed contractor.
1. Exterior Type: Use Category UCFB, chemically treated, and pressure impregnated; capable of providing a maximum flame spread rating of 25 when tested in accordance with ASTM E84, with no evidence of significant combustion when test is extended for an additional 20 minutes both before and after accelerated weathering test performed in accordance with ASTM D2898.
 - a. Treat exposed exterior rough carpentry items, including stairways, balconies, and covered walkways.
 - b. Do not use treated wood in direct contact with the ground.
 2. Interior Type: Use Category UCFA, low temperature (low hygroscopic) type, chemically treated, and pressure impregnated; capable of providing a maximum flame spread rating of 25 when tested in accordance with ASTM E84, with no evidence of significant combustion when test is extended for an additional 20 minutes.
 - a. Treat rough carpentry items as indicated.
 - b. Do not use treated wood in applications exposed to weather or where the wood may become wet.

2.05 FASTENERS AND ACCESSORIES

- A. General requirements for fasteners:
1. Fasteners shall be of adequate size, spacing, and number to resist design loads under intended use, and types shall be appropriate for the materials or conditions for which used.
 2. Provide washers, pre-drilling, etc. as required for proper installation and to prevent damage to framing.
 3. Fasteners shall be hot-dip galvanized (ASTM A153), mechanically galvanized (ASTM B695 class 55 minimum), stainless steel (type 303, 304, 305, or 316), silicon bronze, or copper by approved methods for the following applications:
 - a. Exterior, exposed use.
 - b. In contact with preservative or fire-retardant treated wood.
 4. Fasteners in moist corrosive atmosphere to be of stainless steel (type 303, 304, 305, or 316).
 5. Where the retention level of ACQ or MCQ preservative is greater than 0.40 pcf, CBA-A preservative is greater than 0.41 pcf, or CA-B preservative is greater than 0.21 pcf, provide stainless steel fasteners (type 303, 304, 305, or 316).

6. All fasteners specified by manufacturer shall be installed in framing hardware, unless noted otherwise.
- B. Nails and nailing not otherwise shown or specified:
1. Comply with requirements of governing building code.
 2. For securing materials to hardened concrete or masonry provide hardened steel masonry nails or Simpson Strong-Tie "Titen" screws.
 3. For framing and general woodwork: Common bright wire nails (not box nails) per ASTM F1667. 16d cement coated sinker nails may be used in lieu of common nails for framing, where noted on the drawings.
 4. Nails for sheathing panels shall be of common wire with full round heads and shall be of sufficient length to fully develop the nails.
 5. Machine-driven nails of all types must comply with the requirements of this section. All proposed nails shall match diameter and penetration of specified nails.
 6. Staples shall conform to length and gauges specified and shall be installed to match specified patterns and spacing.
 7. Powder-Driven Pins (PDP): Use only as approved by the Architect/Engineer; operators shall be qualified.
- C. Bolts: Malleable iron washers or steel plate washers, unless otherwise shown, shall be provided under all bolt heads and nuts.
1. Machine Bolts: ASTM A307 and ANSI/ASME B18.2.1, standard semi-finished machine bolts as shown or required. Nuts shall be standard size unless noted otherwise and shall be per ASTM A563.
 2. Bolts in Concrete: Post-installed concrete anchors shall be Hilti "Kwik Bolt TZ", Simpson Strong-Tie "Strong Bolt 2", Hilti "Kwik HUS EZ", or Simpson Strong-Tie "Titen HD" except where shown to be cast-in-place machine bolts or anchor rods.
 3. Anchor bolts or threaded rod anchors shall conform to ASTM F1554, ASTM A307, or ASTM A36. Anchor bolts shall be headed or end in two nuts tightened against one another, unless noted otherwise. Provide embedded plate washer as indicated on drawings. No upset threads allowed. No L or J bolts allowed.
- D. Lag screws: Standard hex lag screws per ANSI/ASME B18.2.1.
- E. Wood screws: Standard wood screws per ANSI/ASME B18.6.1.
- F. Powder-Driven Pins (PDP): Hilti X-CP72, ICC ESR-2379; Simpson PDPWL-300 MG, ICC ESR-2138.
- G. Framing hardware: Fabricated sheet metal timber framing connectors shall be manufactured from painted or galvanized G90 steel by Simpson Strong-Tie (connectors specified on drawings are per Simpson Strong Tie, USP Lumber Connectors, or approved equivalent. Connectors shall be at least 16 gauge material, (1/8 inch plate materials where welded), unless otherwise noted, punched for nailing. All heavy hardware to be fabricated from A36 steel per Division 05, Metals. All hardware intended for exterior exposed use shall be galvanized per G185 ASTM A653 or stainless steel.

1. For contact with preservative or fire-retardant treated wood, provide minimum G185 galvanizing per ASTM A653.
 2. Nails and nailing shall conform to the manufacturer's instructions with a nail provided for each punched hole. Nails to be used with framing accessories are subject to the requirements specified in this Section for fasteners and anchors.
- H. Subfloor Glue: Water proof, water base, air cure type, cartridge dispensed conforming to APA Standard AFG-01 or ASTM D3498. Maximum Volatile Organic Compound (VOC) shall meet local air quality standards and the California Green Building Code.

2.06 SOURCE QUALITY CONTROL

- A. The Testing Agency, as specified in the Article QUALITY ASSURANCE, will perform testing for moisture content of all lumber at time of fastener installation.
- B. The Testing Agency will submit reports as specified in Division 01.

PART 3 EXECUTION

3.01 REQUIREMENTS FOR STRUCTURAL FRAMING

A. General

1. Refer to drawings for layouts, notes and details, provide framing as required; comply with governing building code requirements.
2. Provide framing to achieve true alignments as surfaces receiving finish materials.
3. It shall be the responsibility of the Contractor to provide and install all wood blocking, furring strips, or grounds detailed or required to provide anchorage for all finishes, accessories, fixtures, etc. as required to complete all work. All blocking and/or backing shall be securely bolted or otherwise anchored in place.
4. Contractor shall be responsible for layout of anchor bolts, and other hardware embedded in concrete when placed by other trades.
5. Provide and install all structural framing, blocking, fasteners, brackets, clips, etc. as required to complete work specified in the Construction Documents.

B. Framing

1. Sill Plates and Ledgers:
 - a. Sill plates and ledgers on concrete shall be anchored with bolts, unless noted otherwise, shall have full bearing on concrete, and shall be placed for sheathing panel nailing as indicated. All bolt nuts shall be provided with a cut plate steel washer for bearing on wood.
 - b. Provide a minimum of two sill anchor bolts per sill piece with a bolt no less than 4 1/2" and no more than 12" from the end of the sill. Bolts to be 5/8" diameter x 12" (18" at curb) long at 48" on centers, unless otherwise shown or noted. Provide additional anchor bolts each side of a notch or hole, as per a typical plate splice, where notch or hole is in excess of 1/3 the plate width. At shear walls, provide a plate washer 3" x 3" x 0.229" minimum between the sill and nut at anchor bolts. Plate washer to extend within 1/2 inch of the structural wall sheathing. Offset and/or stagger anchor bolts, or provide larger plate washer as required.

- c. Anchor bolt holes in sill plates or ledgers shall be 1/16" maximum larger than anchor bolt.
2. Stud Walls and Framing:
 - a. Cut studs and posts with square ends, unless otherwise shown or noted. All posts and beams shall be "cut to bear" unless otherwise detailed.
 - b. All studs in walls shall be placed with the shortest dimension parallel to the run of the wall. Bearing studs shall extend full height to be the supporting framing as shown; non-bearing studs shall extend to the supporting framing.
 - c. Provide double studs on each side of all openings, unless shown or noted otherwise.
 - d. All openings in stud walls and partitions shall be framed with headers across the top, as shown, with a minimum size (6" nominal depth x stud width) resting on short cripple studs, and as shown on the drawings.
 - e. All stud partitions and walls shall have horizontal solid blocking not less than 2x and of the same width as the stud, fitted and nailed into the studs at mid-height of stud, for studs over 8 feet in height, except as otherwise shown or specified. This blocking shall be so spaced that there shall be no concealed air spaces greater than eight feet in any dimension.
 - f. Stud partitions containing plumbing, heating or other pipes shall be so framed as to give proper clearance for piping. Plumbing, heating and vent pipes exceeding 1-1/2" in inside diameter shall not be placed in partitions used as bearing or shear walls unless completely furred clear of the wall. No notching shall be allowed. Pipes shall be placed in the center of the plate using a neat bored hole and the plates shall be strapped on each side with 3" x 36" x 14 gauge steel punched for 10d nails 3" on center, staggered, or as shown on the drawings.
3. Top Plates
 - a. Top plates shall be double, set single. Corners where stud wall or partitions meet shall be framed with studs on all surfaces and blocking to form a "rigid" corner with nailing for all corners. Double top plates shall be lapped at corners. Lap splices and nailing per the drawings.
4. Floor, Roof and Ceiling Framing
 - a. Joists and beams shall be accurately aligned and the position and spacing of all joists and beams shall be as shown and be coordinated with other framing and to other trades prior to actual construction.
 - b. Place all joists and beams with crown up. Cantilevered joists and beams shall be placed with the crown down.
 - c. Cutting of wood girders, beams or joists for electrical and mechanical lines shall be limited to cuts and bored holes not deeper than 1/5 of the beam depth from the top and located not farther from the support than three times the beam depth and not less than the beam depth. Cuts in excess of this, or single bored holes with a diameter of more than 1" are not permitted without special provisions for framing the beams. Location of all cuts in framing shall receive the prior review of the Architect/Engineer.
 - d. Provide vent holes in rafters and/or blocking as shown and/or directed by the Architect.

3.02 STRUCTURAL SHEATHING

A. General

1. Sheathing nailing shall be as required on the drawings. Do not overdrive (Do not break skin of sheathing face sheet). Over driving will be cause for rejection.
 2. Form sheathing may be re-used for concealed sheathing provided the lumber at the time of re-use is approved by the Architect, meets with the framing grade requirements specified herein, is in good condition, and is thoroughly cleaned with all nails removed.
 3. Pneumatic nailing devices shall be adjustable so that nail heads do not penetrate skin of sheathing. Contractor shall submit equipment and nails for review prior to use. Refer to PART 2 for other nailing requirements.
- B. Roof and Floor Sheathing: Except "Panelized Roofs", lay with face grain perpendicular to roof rafters, roof trusses or floor joists. Stagger sheets. Block all unsupported sheet edges with 2x material unless noted otherwise.
- C. Wall Sheathing: Lay with face grain either parallel or perpendicular to studs. Exposed bottom edges shall be sealed as recommended by manufacturer. Block all unsupported sheet edges with 2x materials unless noted otherwise.
- D. Panelized Roofs: Where sheathing is set @ 8'-0 1/8" spacing, cut every fourth sheet short by 1/2" to re-align structural framing that has been specified to be spaced at even units of 2, 4 or 8 feet.

3.03 ROUGH HARDWARE

- A. General: Nails, spikes, screws, fabricated sheet metal anchors, ties, hangers and any other materials shown or required for the attachment of wood to concrete and wood to steel and wood to wood shall be furnished and installed as part of this work.
- B. Framing Nailing: All framing nailing shall conform to minimum requirements of the Building Code, and with details shown on the drawing.
- C. Bolts, Lag Screws and Washers:
1. Bolts in wood shall be machine bolts unless otherwise noted and shall be of such length that the bearing length of the treads does not exceed ¼ of the full bearing length in the member holding the treads. Bolt holes in wood shall be 1/32" oversized. Bolt holes for sill plates may be 1/16" maximum oversize. Holes in steel shall be 1/16" oversize. See Section 3.1 for anchor bolts at sill plates and ledgers.
 2. Provide square plate or malleable iron washer and nut at head where bearing is against wood; cut washer under nut where it is against steel. Washer will not be required under head of carriage bolts. Provide malleable iron washers where exposed.
 3. All nuts shall be tightened when placed and retightened at completion of the job or immediately before closing with final construction.
 4. Lag screws shall be screwed (not driven) into place. Drill pilot hole to 70% of shank diameter. Drill clearance hole to full shank diameter and depth of unthreaded screw length.
- D. Wood Screws: Minimum penetration is 10 diameters unless noted otherwise. Where fastening hardwood timber species or where wood tends to split, provide pilot hole 70% of screw shank diameter.

3.04 INSTALLATION OF ACCESSORIES AND MISCELLANEOUS WOOD

- A. Coordinate installation of wood decking, metal-web wood joists, glued-laminated wood construction, shop-fabricated wood trusses, and wood I- joists.
- B. Curb roof openings except where prefabricated curbs are provided. Form corners by alternating lapping side members. Fasten curbs corner-to-corner and to rafters with framing connectors configured for this application.
- C. Blocking:
 - 1. Provide fire blocking at locations and spacing's as required by CBC Chapter 7. Locate other blocking, supplementary framing, backing plates and bracing to facilitate installation of finish materials, fixtures, equipment, services, accessories, and trim requiring attachment and support.
 - 2. Solid block joists and rafters over all supports with blocking of the same size and material as the joist or rafter.
- D. Furring:
 - 1. Nominal 1 inch x 3 inch minimum, continuous and spaced at 16 inches on center, maximum.
 - 2. Install plumb, rigid, and level. Shim where necessary to provide a true, even plane suitable to receive the finish required.
 - 3. Attach to concrete and masonry as shown in the contract drawings.
- E. Bridging: Use 2 inch solid cross bridging. Nail bottom ends of bridging only after sheathing has been nailed.
- F. Stair Framing: Provide with 3 stair stringers for each set of stairs, unless otherwise shown. Cut notches to receive exact size of treads and risers (if any) shown, with no change in dimensions between landings. Provide stringers of size shown, or if not shown, of a size to allow not less than 3-1/2 inch of effective depth, measured perpendicular to the rake of the stringer, after notching.
- G. Install miscellaneous metal angles, bolts, and other items; secure into formwork where embedded in concrete.
- H. Install accessory items not otherwise set under other sections; after completion of painting and other finishing work; in locations shown or directed by the Architect. Set items plumb, level, and secure using appropriate fastening as applicable.

3.05 FIELD APPLIED WOOD TREATMENT

- A. Field treat all end cuts and holes in preservative treated materials per PART 2.
- B. Apply two brush coats; or full-immersion dip not less than 15 minutes; or as required to thoroughly saturate all surfaces after cutting.
- C. Air dry 2-hours minimum before installation.

3.06 TOLERANCES

- A. Framing Members: 1/4 inch from true position, maximum.
- B. Surface Flatness of Floor: 1/8 inch in 10 feet maximum, and 1/4 inch in 30 feet maximum.
- C. Variation from Plane (Other than Floors): 1/8 inch in 10 feet maximum, and 1/4 inch in 30 feet maximum. Provide framed substrates meeting requirements for application of finishes specified in other sections.
- D. Exposed surfaces shall be free from dents and tool marks, unsanded rough or torn faces and corners, and other defects.

3.07 FIELD QUALITY CONTROL

- A. The Testing Agency, as specified in the Article QUALITY ASSURANCE, will perform the following tests and submit reports as specified in Division 01:
 - 1. Moisture content of all lumber at time of close-in.
 - 2. Periodic special inspection of nailing, bolting, and other fastening within the seismic-force-resisting system including shear walls, wood diaphragms, etc. per CBC Section 1705A.12.2.
 - 3. Special inspection of high load diaphragms per CBC Section 1705A.5.1 where designated on documents.

3.08 ADJUSTING

- A. Replace all defective work at Contractor's expense.
- B. Replace defective or damaged work with conforming work.
- C. Correct defects using means that will not injure the materials.
- D. Replace defective or damaged work which cannot be corrected in the field with new work, or return defective items to the shop for repair.
- E. Repair or replace framing lumber sagged, twisted or warped due to shrinkage from excessive moisture content at time of installation, or from other causes.
- F. Adjust to meet specified tolerances.
- G. Architect/Engineer shall review all proposals for the repair or replacement of damaged, defective, or missing work.
- H. Pay expenses incurred by Owner for Architect/Engineer's costs for (re-)design and obtaining approvals of Authorities Having Jurisdiction (AHJ) necessitated by incomplete, inefficiently scheduled, improperly performed, defective or nonconforming work.
- I. Pay expenses due to re-testing and re-inspection necessitated by incomplete, inefficiently scheduled, improperly performed, defective or nonconforming work.

3.09 CLEANING AND PROTECTION

- A. Clean all surfaces upon completion of erection, leave free of grime and dirt. Remove unused materials, tools, equipment, and debris from the premises and leave surfaces broomed clean.
- B. Waste Disposal: Comply with the requirements of pertinent sections of Division 01 specifying cleaning and disposal.
 - 1. Comply with applicable regulations.
 - 2. Do not burn scrap on project site.
 - 3. Do not burn scraps that have been pressure treated.
 - 4. Do not send materials treated with pentachlorophenol, CCA, or ACA to co-generation facilities or "waste-to-energy" facilities.
- C. Do not leave any wood, shavings, sawdust, etc. on the ground or buried in fill.
- D. Prevent sawdust and wood shavings from entering the storm drainage system.
- E. Protect work from damage by subsequent operations.

END OF SECTION

SECTION 06 1733

WOOD I-JOISTS

PART 1 GENERAL

1.01 SUMMARY

- A. Section Include: The furnishing and installation of all wood I-joists as shown on the drawings, herein specified and necessary to complete the work.
- B. Related Sections
 - 1. Pertinent sections of Division 01 specifying Quality Control and Testing Agency Services.
 - 2. Pertinent sections of Division 06 specifying Rough Carpentry.

1.02 REFERENCES

- A. California Code of Regulations, Title 24, latest adopted edition (herein noted as CBC) Chapter 23 Wood.
- B. American National Standards Institute (ANSI) / American Wood Council (AWC) "National Design Standard (NDS) for Wood Construction".
- C. International Code Council Evaluation Service (ICC-ES) "Acceptance Criteria (AC) 14 Prefabricated Wood I-Joists".
- D. American Society for Testing and Materials (ASTM) D5055 "Standard Specification for Establishing and Monitoring Structural Capacities of Prefabricated Wood I-Joists".

1.03 SUBMITTALS

- A. Submit shop drawings, furnished by the Manufacturer, showing all critical dimensions for determining fit and placement in the building and erection instructions.

1.04 QUALITY ASSURANCE

- A. All wood I joists shall be manufactured in a shop approved for fabrication by the Authority Having Jurisdiction (AHJ).
- B. Wood I-joists are not required to be continuously inspected during fabrication, but must carry a stamp indicating the plant of manufacture, date of manufacture, and logo of the third party independent inspection agency, conforming to AC14, and ASTM D5055.
- C. Fabricators must have a minimum of three years experience in manufacturing comparable systems and shall have a valid evaluation report issued by a qualified evaluation agency prescribed in DSA IR A-5.
- D. Wood I-joists delivered shall be free from any defects in materials, and the members shall be adequate to carry the design loads for the life of the building.

PART 2 PRODUCTS

2.01 MATERIALS

- A. Joists shall be manufactured from materials in the evaluation report and shall be of sizes and shapes shown on the contract documents.
- B. Blocking construction shall be the same as I-joists, unless noted otherwise.

2.02 FABRICATION

- A. Camber - None, unless noted otherwise.
- B. Tolerances:
 - 1. Length (between outside bearing edges): +/- 1/2 inch
 - 2. Depth: +/- 3/8 inch
 - 3. Camber: +/- 1/4 inch

PART 3 EXECUTION

3.01 PRODUCT DELIVERY, STORAGE AND HANDLING

- A. Wood I-joists shall be stored in a vertical position and protected from the weather. They shall be handled with care so they are not damaged. Provide bearing supports and bracings to avoid bending or overturning of I-joists, and protect I-joists from construction operations.

3.02 ERECTION AND INSTALLATION

- A. Use all means necessary to coordinate the work of this section with the work of other sections to ensure proper and adequate erection of the work of this section.
- B. Wood I-joists shall be installed in accordance with the approved shop drawings and installation instructions therein.
- C. Temporary construction loads, which will cause member stresses beyond design limits, are not permitted.
- D. Erection bracing in addition to specified bridging is to be provided to keep the I-joists straight and plumb as required to assure adequate lateral support for the individual I-joist and entire system until the sheathing material has been applied. Bridging as shown on the drawings and per Manufacturer's recommendations shall be installed as erection of I-joists progresses and before any construction loads are placed on the I-joists.
- E. Round holes may be cut in the I-joist web as indicated on the drawings. Square or rectangular holes may be cut when the diagonal dimension of the square or rectangular hole does not exceed the diameter of the maximum allowable round holes shown on the drawing. Overcut square or rectangular holes shall be treated as a hole matching the overcut. Holes exceeding maximum holes shown on the drawings are cause for rejection of the I-joist.

- F. The Contractor shall give notification prior to enclosing the I-joists to provide opportunity for inspection of the installation.

END OF SECTION

SECTION 06 1800

GLUED LAMINATED CONSTRUCTION

PART 1 GENERAL

1.01 SUMMARY

- A. Section Includes: All labor, materials and equipment for glued laminated timber necessary to complete work shown, implied, specified and required.
- B. Related Sections:
 - 1. Pertinent sections of Division 01 specifying Quality Control and Testing Agency services.
 - 2. 06 1000 Rough Carpentry

1.02 REFERENCES

- A. California Code of Regulations, Title 24, latest adopted edition (herein noted as CBC): Chapter 23 Wood.
- B. American National Standards Institute (ANSI) A190.1 "Standard for Wood Products - Structural Glued Laminated Timber".
- C. ANSI 117 "Standard Specification for Structural Glued Laminated Timber of Softwood Species".
- D. American Society for Testing and Materials (ASTM) D3737 "Standard Practice for Establishing Allowable Properties for Structural Glued Laminated Timber (Glulam)".

1.03 SUBMITTALS

- A. Submit in accordance with pertinent sections of Division 01 specifying submittal procedures. The General Contractor shall review and approve shop drawings prior to submittal to the Architect/Engineer. Submittals that do not meet these requirements will be returned for correction without review.
- B. Limitation of Review: Structural Engineer's review will be for general conformance with design intent as indicated in the Contract Documents and does not relieve Contractor of full responsibility for conformance with the Contract Documents.
- C. Shop Drawings: Submit each building as a complete unit. Do not mix components from multiple buildings or units of work in a submittal. Include all of the following:
 - 1. Indicate profiles, sizes, lengths, appearance grade, and locations of structural members.
 - 2. Cross-reference all shop drawing detail references to contract document detail references.
 - 3. Secure all field measurements as necessary to complete this work, prior to submittal.
- D. Certifications:
 - 1. ANSI/AITC Certificate of Conformance.
 - 2. Special Inspection Certification.

E. Warranty:

1. Two copies of a five-year warranty, signed by an officer of the manufacturer, shall be submitted to the Architect/Engineer stating that the workmanship shall be corrected to the satisfaction of the Architect/Engineer at no cost to the Owner.

1.04 QUALITY ASSURANCE

- A. Each glued laminated member shall bear the ANSI/AITC Quality Mark to indicate conformance to ANSI A190.1.
- B. All tests shall be performed by a recognized testing agency as specified in pertinent sections of Division 01.
- C. Certification and Identification of Materials and Uses: Provide Testing Agency with access to fabrication plant to facilitate inspection of fabrication. Provide notification of commencement and duration of shop fabrication in sufficient time to allow inspection and all material identification.
- D. Testing and Inspection: Tests and Inspections performed by Independent Testing Agency are specified below in Article SOURCE QUALITY CONTROL. Duties and limitations of Independent Testing Agency, test costs, and test reports to be in conformance with pertinent sections of Division 01.

PART 2 PRODUCTS

2.01 MATERIALS

- A. Lumber
 1. Conform to ANSI/AITC 117.
 2. Laminations shall be 2 inch nominal thickness unless otherwise noted.
 3. 16% maximum moisture content (MC) at time of manufacture (12% for mechanically reinforced members).
 4. All laminations to be greater than 90% heartwood, unless noted otherwise.
- B. Adhesive: Shall be exterior grade for wet surface condition above 16% and shall meet requirements of ANSI 405.
- C. Interior use glue laminated members shall be manufactured entirely from Douglas Fir.
 1. Simple span beams shall be combination 24F-V4-1.8E.
 2. Beams with intermediate supports and/or cantilevers shall be combination 24F-V8-1.8E.
 3. Posts and truss members shall be combination 3-1.9E.
- D. Glue laminated members that are protected from weather by a roof, eave, or similar covering may be Douglas Fir. The ends shall be flashed and treated with approved wood preservative to prevent decay.
- E. Glue laminated members with exterior exposure shall be fabricated entirely from Alaskan

Yellow Cedar (AYC). No sap wood permitted.

1. Simple span beams shall be combination 20F-V12-1.5E.
2. Beams with intermediate supports and/or cantilevers shall be combination 20F-V13-1.5E.
3. Posts and truss members shall be combination 20F-V13-1.5E.

F. Radial Tension Reinforcement: ANSI/AITC 404.

2.02 CAMBER

- A. All beams shall be cambered as noted on the drawing. Where no camber is noted, provide 5,000 ft radius camber at simple span beams.
- B. Cambers specified shall be provided within tolerances per ANSI A190.1. The Contractor shall verify all beam cambers prior to the erection and report his findings in writing to the engineer for review and comment.

2.03 APPEARANCE

- A. Glued laminated members shall be Industrial Appearance Grade when not exposed to permanent view and Architectural Appearance Grade otherwise. Appearance to meet the requirements of ANSI A190.1.

2.04 PROTECTION

- A. Protection during shipping and field handling to meet requirements of AITC 111, including protective wrapping and proper storage of members to prevent increased moisture content and damage. Individually wrap members with Architectural Appearance Grade.
- B. Ends shall be sealed after end trimming and entire surface of members shall be factory sealed with a penetrating sealer that has been approved by the Architect. Field cuts, notches, and daps shall receive one coat of the same sealer prior to erection.

2.05 SOURCE QUALITY CONTROL

- A. Special Inspection is not required for non-custom members with maximum 6 inch nominal width, maximum 18 inch depth, and maximum 32 feet clear span per CBC section 1705A.5.4. Provide an ANSI/AITC certificate for each member.
- B. Members not meeting the above criteria shall be continuously inspected during fabrication by a glue fabrication inspector specifically approved for that purpose. The Inspection shall conform to CBC requirements. An ANSI/AITC Certificate will not meet this requirement.
 1. An independent Testing Agency will perform source quality control tests and submit reports, as specified in pertinent sections of Division 01 and CBC Chapter 17A.
 2. The inspector shall issue four copies of certificates to the Architect/Engineer certifying that materials, manufacture and fabrication are in accordance with these Specifications and the Drawings and shall specify the following:
 - a. Species, grade and slope of grain of lumber. Lumber grading inspection shall be done by lumber graders authorized under the provisions of the American Lumber Standards Committee and verified by the special independent inspector.

- b. Glue quality specified.
 - c. Glue bond over entire surface.
 - d. Continuous inspection of gluing operation.
 - e. Moisture content of laminations during manufacture.
 - f. Finger joint locations.
 - g. All requirements of ANSI A190.1 are met.
3. Each inspected member shall be stamped by the special inspector with an identification mark.

PART 3 EXECUTION

3.01 ERECTION

- A. Members shall be seat cut to bear, dapped, etc. as detailed on the drawings prior to erection.
- B. Members shall be erected with suitable equipment and secured in place as detailed on the drawings.
- C. Glued laminated members shall be aligned and braced until all secondary members or other framing is secured. Contractor shall verify all beam cambers in the field prior to erection.

3.02 CLEANING

- A. All debris resulting from this portion of the work shall be removed from the site upon completion.
- B. Protect work from damage by subsequent operations.

END OF SECTION

SECTION 06 2000
FINISH CARPENTRY

PART 1 GENERAL

1.01 SECTION INCLUDES

- A. Finish carpentry items.
- B. Interior and exterior wood trim;

1.02 RELATED SECTIONS

- A. Section 01 6116 - Volatile Organic Compound (VOC) Content Restrictions.
- B. Section 01 8113 - Sustainable Design Requirements.
- C. Section 06 1000 - Rough Carpentry: Support framing, grounds, and concealed blocking.
- D. Section 06 4100 - Architectural Wood Casework: Shop fabricated custom cabinet work.
- E. Section 09 9123 - Interior Painting: Painting and finishing of finish carpentry items. Backpriming of finish carpentry.
- F. Division 32 - Pertinent Sections specifying wood landscape headers and stakes, fences, gates, benches.

1.03 REFERENCE STANDARDS

- A. ASTM Standards: A153, A165, D 226
- B. ASTM E84 - Standard Test Method for Surface Burning Characteristics of Building Materials.
- C. AWWPA C2 - Lumber, Timber, Bridge Ties and Mine Ties -- Preservative Treatment by Pressure Processes; American Wood-Preservers' Association.
- D. BHMA A156.9 - American National Standard for Cabinet Hardware.
- E. California Code of Regulations, Title 24, Part 2, California Building Code (CBC), International Building Code.
- F. California Code of Regulations, Title 24, Part 11 California Green Building Standards Code, "CAL-Green".
- G. PS 1 - Structural Plywood.
- H. PS 20 - American Softwood Lumber Standard.
- I. PS-51 for decorative plywood.
- J. Redwood Inspection Service (RIS): "Standard Specifications for Grades of California Redwood Lumber" 2000 ed, www.calredwood.org.
- K. West Coast Lumber Inspection Bureau (WCLIB): "Standard Grading and Dressing Rules No. 16".

1.04 SUBMITTALS

- A. See Section 01 3300 - Submittals for submittal procedures.
- B. Product Data:
 - 1. Manufacturer's storage, handling and installation instructions
 - 2. Provide instructions for attachment hardware and finish hardware.
- C. CAL-GREEN Submittals:

1. Product Data – VOC Limits: For adhesives, sealants, fillers, primers and coatings, documentation including printed statement of VOC contents, comply with limits specified in related section.
2. Composite Wood Formaldehyde Limits: Provide certification that all products meet current CARB Airborne Toxic Control Measure (ATCM) for Composite Wood Formaldehyde Limits by Mandatory Compliance Dates as specified in related section.

D. Mill grade certificate, if material cannot be marked on a concealed surface.

1.05 QUALITY ASSURANCE

- A. Perform work in accordance with Woodwork Institute Manual of Millwork, Custom grade.
- B. Factory-mark each piece of lumber and plywood with type, grade, mill and grading agency identification; except omit marking from surfaces to receive transparent finish.
- C. Fabricator Qualifications: Company specializing in fabricating the products specified in this section with minimum five years of documented experience.

D.

1.06 DELIVERY, STORAGE, AND HANDLING

- A. Wood: Store indoors, in well ventilated area at maximum relative humidity of 60 percent and in accordance with WIC technical bulletin 419-R.
- B. Protect work from moisture damage.

1.07 PROJECT CONDITIONS

- A. Sequence installation to ensure utility connections are achieved in an orderly and expeditious manner.
- B. Coordinate the work with plumbing rough-in, electrical rough-in, installation of associated and adjacent components, and interior finishes.

PART 2 PRODUCTS

2.01 PERFORMANCE REQUIREMENTS

- A. VOC Limits for adhesives, sealants, fillers, primers and coatings . Comply with limits specified in related section.
- B. Composite Wood products must meet current CARB Airborne Toxic Control Measure (ATCM) for Composite Wood Formaldehyde Limits by Mandatory Compliance Dates as specified in Section 01 6116.

2.02 FINISH CARPENTRY ITEMS

2.03 WOOD-BASED COMPONENTS

- A. Wood fabricated from old growth timber is not permitted.

2.04 LUMBER MATERIALS

- A. Exterior wood: Dry; with moisture content up to 15 percent, unless otherwise indicated.
 1. Exterior Trim and Fascias, opaque finish: Redwood Inspection Service Paragraph 107 - "Grade B". RIS Paragraph 109 "Select" for material thinner than 2 inch, and Paragraph 117 "Select" for 2 inch and thicker; S4S; smooth surfaced.
- B. Interior wood: Dry; with moisture content between 6 and 12 percent, unless otherwise indicated. Finger joints not permitted. WI manual, Section 3 and Section 4; "Custom Grade"
 1. Softwoods:
 - a. Opaque Finish: Clear; western softwood.

2.05 FASTENINGS

- A. Adhesive for Purposes Other Than Laminate Installation: Suitable for the purpose; not containing formaldehyde or other volatile organic compounds.
- B. Rough Hardware and fasteners: Provide nails, screws, anchor bolts, machine bolts, expansion sleeves, lag screws, powder driven fasteners, joist hangers, straps, and other framing anchors of the size and type required to securely attach finish carpentry to substrates.
 - 1. Nails:
 - a. Exterior Trim Exposed: Nichols-Homeshield, Independent Nail and Packing,
 - 2. Other Exterior Work: Hot-dip galvanized steel.
 - 3. Interior Work: Steel, typical unless otherwise indicated.
 - 4. Screws, Bolts, Washers:
 - a. Exterior Work: Hot-dip galvanized steel, ASTM A153.
 - b. Interior Work: Cadmium plated steel, ASTM A165.
 - 5. Framing Devices:
 - a. Exterior Work: Hot-dip galvanized steel, ASTM A153.
 - b. Interior Work: Plated, ASTM A165; or painted steel.
- C. Concealed Joint Fasteners: Threaded steel.

2.06 ACCESSORIES

- A. Adhesive and Tape
 - 1. 1. Wood Adhesive: Essex Chemical "Webtex 588", Inmont "Presstite 220", 3M "Scotch-Grip 4314" or equal.
- B. Lumber for Shimming and Blocking: Softwood lumber of indicated species.
- C. Primer: as specified in pertinent sections of Division 09 for finish type indicated.
- D. Wood Filler: Solvent base, VOC Compliant, tinted to match surface finish color. Duratite "Wood Dough", Boyle-Midway "Plastic Wood" or equal.

2.07 FABRICATION

- A. Shop assemble work for delivery to site, permitting passage through building openings.
- B. Mill and fabricate units and pieces as long as practical.
- C. Finish and assemble at shop to greatest extent possible.
- D. Finish to specified standards of Architectural Woodwork Standards (AWS) Manual.
 - 1. Opaque finish, unless otherwise indicated.
- E. When necessary to cut and fit on site, provide materials with ample allowance for cutting. Provide trim for scribing and site cutting.

PART 3 EXECUTION

3.01 EXAMINATION

- A. Verify location of blocking, adequacy of backing and support framing.
- B. Verify mechanical, electrical, and building items affecting work of this section are placed and ready to receive this work.

3.02 PREPARATION

- A. Separate units and condition wood materials for a minimum of 72 hours. Allow wood to achieve prevailing humidity conditions in installation areas prior to installing.
- B. Backprime lumber, including side and ends, before installation for:
 - 1. Exposed exterior surfaces;
 - 2. Where surface is exposed to interior moisture and high relative humidities.

3.03 INSTALLATION

- A. Trim and bases: Install with minimum number of joints possible. Use full-length pieces from maximum lengths of lumber available.
 - 1. Stagger joints in adjacent and related members.
 - 2. Cope at returns and miter at corners. Produce tight fitting joints with full surface contact throughout length of joint.
 - 3. Joints: End-to-end
 - a. Wood: Scarf.
 - 4. Locate wood bases above subfloor by the thickness of finish flooring.
- B. Set and secure materials and components in place, plumb and level.
- C. Carefully scribe work abutting other components, with maximum gaps of 1/32 inch. Do not use additional overlay trim to conceal larger gaps.
- D. Building paper: Install under exterior wood; without holes or tears.
- E. Lap flashings to weather to the exterior.
 - 1. Lap horizontal edges 3-inches minimum and vertical edges 6-inches minimum
 - 2. Lap sheet metal flashings; double layer at corners by extending 6-inches around corner from each side.
- F. Anchorage: Drill pilot holes for nails where necessary to preclude splitting or chipping of material.
 - 1. Anchor finish carpentry work to anchorage devices or blocking built-in or directly attached to substrates. Secure to grounds, stripping and blocking with countersunk, concealed fasteners.
- G. Blind nail where possible and use fine finishing nails for exposed nailings, countersunk and filled flush with finished surface.
- H. At exterior locations drive nails flush.

3.04 PREPARATION FOR SITE FINISHING

- A. Set exposed fasteners. Apply wood filler in exposed fastener indentations. Sand work smooth. Prepare in accordance with level of finish specified in Section 09 9000.
- B. Before installation, prime paint surfaces of items or assemblies to be in contact with cementitious materials.

3.05 TOLERANCES

- A. Tolerances
 - 1. Install the work plumb, level, true and straight with no distortions. Conceal shims.
 - a. 1/16-inch maximum offset in flush adjoining surfaces.
 - b. 1/8-inch maximum offset in revealed adjoining surfaces.
 - 2. Scribe and cut work to fit adjoining work, and refinish cut surfaces or repair damaged finish at cuts.
- B. Maximum Variation from True Position: 1/16 inch.

3.06 ADJUSTMENT AND FINISHING

- A. Ease salient corners and edges and sand all exposed surfaces of smooth finish wood.
- B. Repair damaged and defective finish carpentry work wherever possible to eliminate functional and visual defects. Chipped or split materials is considered a defect.
- C. Replace where repair is not possible.
- D. Adjust joinery for uniform appearance.

END OF SECTION

SECTION 06 4100
ARCHITECTURAL WOOD CASEWORK

PART 1 GENERAL

1.01 SECTION INCLUDES

- A. Laminated Plastic Casework
- B. Cabinet Hardware

1.02 RELATED SECTIONS

- A. Section 01 6116 - Volatile Organic Compound (VOC) Content Restrictions.
- B. Section 06 1000 - Rough Carpentry: Support framing, grounds, and concealed blocking.
- C. Section 06 2000 - Finish Carpentry
- D. Division 09: pertinent sections specifying finishes adjacent to cabinets.
- E. Section 12 3600 - Countertops.
- F. Pertinent sections specifying plumbing and/or mechanical equipment interfacing cabinets.
- G. Pertinent sections specifying lighting and/or electrical equipment interfacing cabinets.

1.03 REFERENCE STANDARDS

- A. AWI/AWMAC/WI (AWS) - Architectural Woodwork Standards.
- B. AWMAC/WI (NAAWS) - North American Architectural Woodwork Standards, U.S. Version 3.0.
- C. WI (CCP) - Certified Compliance Program (CCP).
- D. WI (MCP) - Monitored Compliance Program (MCP).
- E. California Code of Regulations, Title 24, Part 2, California Building Code (CBC), International Building Code.
- F. California Code of Regulations, Title 24, Part 11 California Green Building Standards Code, "CAL-Green".
- G. Architectural Woodwork Standards (AWS) latest edition, published jointly by the Woodwork Institute, Architectural Woodwork Institute, and the Architectural Woodwork Manufacturer's Association of Canada.

1.04 SUBMITTALS

- A. See Section 01 3300 - Submittals, for submittal procedures.
- B. Shop Drawings: Indicate materials, component profiles, fastening methods, jointing details, and accessories, hardware location and schedule of finishes.
 - 1. Scale of Drawings: 1-1/2 inch to 1 foot, minimum.
 - 2. Provide the information required by AWI/AWMAC/WI (AWS) or AWMAC/WI (NAAWS).
 - 3. Include certification program label indicating that drawings fully meet the requirements of the AWS Millwork Grade specified.
- C. Product Data: Provide data for specified products, including hardware accessories. Demonstrate compliance with specified attributes.
- D. CAL-GREEN Submittals:

1. Product Data - VOC Limits: For adhesives sealants, fillers, primers and coatings, documentation including printed statement of VOC contents, comply with limits specified in related section..
2. Composite Wood Formaldehyde Limits: Provide certification that all products meet current CARB Airborne Toxic Control Measure (ATCM) for Composite Wood. Formaldehyde Limits by Mandatory Compliance Dates as specified in related section.
3. Product Data - Low/No-VOC Paints and Coatings. Provide certification that all primers and coatings meet VOC emission limits specified in related section. List manufacturer, brand, application, type (flat or non-flat), number of gallon, and the VOC emissions in grams/liter. Include MSDS and product data sheet indicating VOC limits for each product provided.

E. Samples:

1. Full range of plastic laminates and edge tapes available from the specified group, of the specified manufacturer.
2. Submit two samples of each hardware item to be provided, illustrating hardware finish .
3. Three 12" x 12" finished samples of each veneer species and finish to be used and three 6" x 12" finished samples of each lumber species and finish.

F. Closeout Submittals: AWS certificates of compliance indicating that installation fully meets requirements of AWS Millwork Grade specified.

1.05 QUALITY ASSURANCE

A. Fabricator Qualifications: Company specializing in fabricating the products specified in this section with minimum five years of documented experience.

1. Company with at least one project in the past 5 years with value of woodwork within 20 percent of cost of woodwork for this Project.
2. Accredited participant in the specified certification program prior to the commencement of fabrication and throughout the duration of the project.

B. Quality Certification:

1. Provide labels or certificates indicating that the installed work complies with AWI/AWMAC/WI (AWS) or AWMAC/WI (NAAWS) requirements for grade or grades specified.
2. Provide designated labels on shop drawings as required by certification program.
3. Provide designated labels on installed products as required by certification program.
4. Submit certifications upon completion of installation that verifies this work is in compliance with specified requirements.
5. Replace, repair, or rework all work for which certification is refused.

C. Single Source Responsibility: A single manufacturer shall provide and install the work described in this Section.

1.06 DELIVERY, STORAGE, AND HANDLING

A. Protect units from moisture damage.

B. Do not deliver woodwork, until the area of operation is enclosed, painting, wet work, grinding, overhead work and similar operations which could damage, soil or deteriorate woodwork are complete and the area is broom clean.

C. If woodwork is stored in other than installation areas, store only in areas meeting requirements specified for installation areas.

D. Do not install woodwork until required temperature and relative humidity are stable and will be maintained in installation areas.

1.07 FIELD CONDITIONS

- A. During and after installation of custom cabinets, maintain temperature and humidity conditions in building spaces in the range recommended by the Architectural Woodwork Standards for the location of the project.

PART 2 PRODUCTS

2.01 PERFORMANCE REQUIREMENTS

- A. VOC Limits for adhesives, sealants, fillers, primers and coatings . Comply with limits specified in related section.
- B. Composite Wood products must meet current CARB Airborne Toxic Control Measure (ATCM) for Composite Wood Formaldehyde Limits by Mandatory Compliance Dates as specified in related section.

2.02 CABINETS

- A. Quality Grade: Unless otherwise indicated provide products of quality specified by AWI//AWMAC/WI (AWS) for Grades as indicated. Refer to SCHEDULES article

2.03 COUNTERTOPS

- A. General: Types specified in Section 12 3600. Provide in accordance with WI Manual Sections cited to match quality grade(s) for cabinets indicated in this Section.

2.04 ACCESSORIES

- A. Adhesive: Type recommended by WI to suit application, urea formaldehyde-free.
 - 1. Wood Glue: Waterproof types as recommended by WI standards for the particular application. VOC content of not more than 30 g/L when calculated according to 40 CFR 59, Subpart D (EPA method 24).
 - 2. Adhesive for Bonding Plastic Laminate: Contact cement, for general use and for postforming. Use unpigmented product with through-color laminate.
- B. Plastic Edge Banding: Extruded PVC, flat shaped; smooth finish; self locking serrated tongue; of width to match component thickness. 3 mm thick, minimum.
 - 1. Color: As selected by Architect from manufacturer's full range.
 - a. Provide minimum of seventy-five color selections coordinated with plastic laminate selections, including patterns and woodgrains.
- C. Fasteners: Size and type to suit application.
- D. Bolts, Nuts, Washers, Lags, Pins, and Screws: Of size and type to suit application; galvanized or chrome-plated finish in concealed locations and stainless steel or chrome-plated finish in exposed locations.
- E. Concealed Joint Fasteners: Threaded steel.
- F. Grommets: plastic material for cut-outs, 2 inch diameter minimum, color as selected.

2.05 HARDWARE

- A. General: Meet or exceed specified requirements of AWI/AWMAC/WI - Architectural Woodwork Standards (AWS) and BHMA Grade 1; US 26D finish or as selected by Architect from manufacturer's standards.
- B. Grommets and covers: 2 inch diameter, ABS plastic; color as selected.
- C. Other Hardware: per referenced standard.

2.06 FABRICATION

- A. Assembly: Shop assemble cabinets for delivery to site in units easily handled and to permit passage through building openings.
- B. Edging: Fit shelves, doors, and exposed edges with specified edging. Do not use more than one piece for any single length.
 - 1. Cap exposed plastic laminate countertop finish ends and edges with material of same finish and pattern. Cap semi-exposed ends and edges with materials permitted by the Referenced Standard. Plastic Tee banding is not acceptable.
 - 2. Plastic Laminate Faced Cabinet Edge Band: 3mm PVC at doors, drawer fronts, false fronts, and at all other edges requiring banding.
 - 3. Wood Faced Cabinet Edge Band: 3mm wood edge band at doors, drawer fronts and false fronts, all other edges per the AWS.
- C. Fitting: When necessary to cut and fit on site, provide materials with ample allowance for cutting. Provide matching trim for scribing and site cutting.
- D. Plastic Laminate: Apply plastic laminate finish in full uninterrupted sheets consistent with manufactured sizes. Fit corners and joints hairline; secure with concealed fasteners. Locate counter butt joints minimum 6 feet from sink cut-outs.

2.07 FABRICATION - COUNTERTOPS

- A. Fabricate countertops as specified in Section 12 3600 and to match quality grade standards specified in this section. In the event of conflict, the higher standard prevails.

2.08 SOURCE QUALITY CONTROL

- A. Labels: Certification of compliance, affixed by WI Inspector at the place of fabrication prior to shipment.

PART 3 EXECUTION

3.01 EXAMINATION

- A. Verify location of blocking, adequacy of backing and support framing.

3.02 INSTALLATION

- A. Set and secure casework in place; rigid, plumb, and level, free of distortions. Shim as required; use concealed shims.
- B. Use fixture attachments in concealed locations wherever possible for wall mounted components. Exposed fasteners at semi-exposed surfaces and exposed interior surfaces are acceptable when required to provide a seismic compliant installation.
 - 1. Exception: Exposed fastening permitted at access panels.
- C. Use concealed joint fasteners to align and secure adjoining countertops.
- D. Carefully scribe casework abutting other work, with maximum gaps of 1/32 inch. Do not use additional overlay trim for this purpose.
- E. Secure countertops to walls using appropriate angles and anchorages.
- F. Countertops: Anchor securely to base units and other support systems and as specified in Section 12 3600.

3.03 TOLERANCES.

- A. Site Tolerances: 1/8 inch in 8 feet for plumb and level; adjoining surfaces flush, without offset.

- B. Cabinet Tolerances: As specified in the referenced standard.

3.04 ADJUSTING

- A. Adjust installed work.
 - 1. Adjust and lubricate moving or operating parts to function smoothly and correctly.
 - 2. Adjust hardware to center doors and drawers in openings and to provide smooth operation.
- B. Touch-up shop-applied finishes to restore damaged or soiled areas.
- C. Repair damaged and defective woodwork and eliminate defects functionally and visually. Where repair is not possible replace woodwork. Adjust joinery for uniform appearance.

3.05 FIELD QUALITY CONTROL

- A. If Architect questions that installation quality may not conform to the specified AWS Quality Grade, Architect may order a final inspection by a WI Inspector.

3.06 CLEANING

- A. Clean casework, counters, shelves, hardware, fittings, and fixtures.

3.07 PROTECTION OF FINISHED WORK

- A. Do not permit finished casework to be exposed to continued construction activity.
- B. Do not store materials or products on countertops. Do not stand or walk on countertops or use for construction access to building elements above floor level.
- C. Protect countertops with durable panel materials secured in place using methods which will not damage surfaces or finishes. Do not remove until Owner acceptance following move-in.

3.08 SCHEDULES

- A. All Locations not specified as part of kitchen equipment:
 - 1. Quality: WI Custom Grade.
 - 2. Cabinet Construction: Plastic laminate faced.
 - 3. Countertops: Plastic laminate.

END OF SECTION

SECTION 07 1113
BITUMINOUS DAMPPROOFING

PART 1 GENERAL

1.01 SECTION INCLUDES

- A. Bituminous dampproofing at exterior retaining walls.
- B. Protection boards.

1.02 RELATED REQUIREMENTS

- A. Pertinent Sections specifying Volatile Organic Compound (VOC) Content Restrictions.
- B. Division 31 and 33 : Pertinent sections specifying earthwork, drainage, trenching and backfill.

1.03 REFERENCE STANDARDS

- A. ASTM D4479/D4479M - Standard Specification for Asphalt Roof Coatings - Asbestos-Free.
- B. NRCA (WM) - The NRCA Waterproofing Manual.
- C. California Code of Regulations, Title 24, Part 11 California Green Building Standards Code, "CAL-Green".

1.04 SUBMITTALS

- A. General: Submit in accordance with Section 01 3300.
- B. Provide complete submittals at the same time as submittals for work in related sections to permit review of complete and integrated systems and assemblies.
- C. Product Data: Provide properties of primer, bitumen, and mastics.
- D. CAL-GREEN Submittals: Product Data - VOC Limits: For adhesives sealants, fillers, primers and coatings, documentation including printed statement of VOC contents, comply with limits specified in related section.
- E. Manufacturer's Installation Instructions: Indicate special procedures and perimeter conditions requiring special attention.

1.05 FIELD CONDITIONS

- A. Maintain ambient temperatures above 40 degrees F for 24 hours before and during application until dampproofing has cured.

PART 2 PRODUCTS

2.01 BITUMINOUS DAMPPROOFING

- A. Bituminous Dampproofing: Cold-applied, spray-grade; asphalt base, volatile petroleum solvents, and other content, suitable for application by spray, brush, roller, or squeegee; asbestos-free; suitable for application on vertical and horizontal surfaces.
 - 1. Composition: ASTM D4479/D4479M Type I, minimum, asbestos free.
 - 2. VOC Content: Not more than permitted by local, State, and federal regulations.
 - 3. Applied Thickness: 1/16 inch, minimum, wet film.
 - 4. Products:
 - a. W. R. Meadows, Inc; Sealmastic Spray-Mastic: www.wrmeadows.com/#sle.
 - b. Substitutions: See Section 01 6000 - Product Requirements.
- B. Primers, Mastics, and Related Materials: Type as recommended by dampproofing manufacturer.

2.02 ACCESSORIES

- A. Protection Board: 1/8 inch thick bitumen impregnated glass fiberboard.
 - 1. Product: "Protection Course" PC-2 Standard Duty manufactured by W. R. Meadows, Inc..

PART 3 EXECUTION

3.01 EXAMINATION

- A. Verify existing conditions are acceptable prior to starting this work.
- B. Verify substrate surfaces are durable, free of matter detrimental to adhesion or application of dampproofing system.
- C. Verify that items penetrating surfaces to receive dampproofing are securely installed.

3.02 PREPARATION

- A. Protect adjacent surfaces not designated to receive dampproofing.
- B. Clean and prepare surfaces to receive dampproofing in accordance with manufacturer's instructions.
- C. Do not apply dampproofing to surfaces unacceptable to manufacturer.
- D. Apply mastic to seal penetrations, small cracks, or minor honeycombs in substrate.

3.03 APPLICATION

- A. Prime surfaces in accordance with manufacturer's instructions and NRCA (WM) applicable requirements.
- B. Apply bitumen with roller or other method approved by manufacturer.
- C. Apply bitumen in 3/16 inch two coats, continuous and uniform, at an approximate rate rate of 3 gal/100 sq ft per coat to a final thickness of 1.59 mm.
 - 1. Allow 12 hours minimum between coats.
- D. Apply from 2 inches below finish grade elevation down to top of footings.
- E. Seal items watertight with mastic, that project through dampproofing surface.
- F. Place protection board directly over dampproofing, butt joints, and adhere to tacky dampproofing.
- G. Scribe and cut boards around projections, penetrations, and interruptions.
- H. Adhere protection board to substrate with mastic

3.04 SCHEDULE

- A. Site Planter Walls: Two coatings of asphalt dampproofing.
- B. Site Retaining Walls not adjacent to conditioned spaces: Two coatings of asphalt dampproofing.

END OF SECTION

SECTION 07 2100

BOARD AND BATT [BUILDING] INSULATION

PART 1 GENERAL

1.01 SECTION INCLUDES

- A. Batt insulation and vapor retarder in interior and exterior wall construction.
- B. Insulation for filling perimeter window and door shim spaces and crevices in exterior wall and roof.

1.02 RELATED REQUIREMENTS

- A. Section 01 6116 - Volatile Organic Compound (VOC) Content Restrictions.
- B. Section 07 2129 - Sprayed Insulation: Sprayed-on, adhered fibrous insulation.
- C. Section 07 8400 - Firestopping: Insulation as part of fire-rated through-penetration assemblies.
- D. Division 23 - Mechanical, Duct and Pipe Insulation.

1.03 REFERENCE STANDARDS

- A. ASTM C665 - Standard Specification for Mineral-Fiber Blanket Thermal Insulation for Light Frame Construction and Manufactured Housing.
- B. ASTM E84 - Standard Test Method for Surface Burning Characteristics of Building Materials.
- C. ASTM E136 - Standard Test Method for Behavior of Materials in a Vertical Tube Furnace At 750 Degrees C.
- D. California Code of Regulations, Title 24, Part 2, California Building Code (CBC), International Building Code.
- E. California Code of Regulations, Title 24, Part 11 California Green Building Standards Code, "CAL-Green".
- F. Manufacturer's recommendations.

1.04 SUBMITTALS

- A. See Section 01 3300 - Submittals, for submittal procedures.
- B. Product Data: Provide data on product characteristics, performance criteria, and product limitations.
- C. CAL-GREEN Submittals:
 - 1. Product Data - VOC Limits: For adhesives sealants, fillers, primers and coatings, documentation including printed statement of VOC contents, comply with limits specified in related section.
 - 2. Certify compliance with 2016 California Referenced Standards Code as referenced in Article PERFORMANCE REQUIREMENTS.
- D. Manufacturer's Installation Instructions: Include information on special environmental conditions required for installation and installation techniques.
- E. Schedule of installation methods for each and every system and condition.
- F. Samples of mechanical supports and fasteners.

1.05 FIELD CONDITIONS

- A. Do not install insulation adhesives when temperature or weather conditions are detrimental to successful installation.

1.06 SEQUENCING

- A. Sequence work to ensure fireproofing and firestop materials are in place before beginning work of this section.

1.07 DELIVERY, STORAGE AND HANDLING

- A. Mark materials on face of package, with manufacturer's name, thickness, and insulation "R " value.

PART 2 PRODUCTS

2.01 PERFORMANCE REQUIREMENTS

- A. VOC Limits for adhesives, sealants, fillers, primers and coatings . Comply with limits specified in related section.
- B. Insulating Material Standards: All insulation materials must comply with the 2016California Referenced Standards Code, California Code of Regulations, Title 24, Part 12 / Chapter 12-13 Standards for Insulating Material.
- C. Roof and wall insulation to provide a complete insulation envelope surrounding all conditioned spaces, as indicated elsewhere in the Contract Documents, and as listed below.

2.02 APPLICATIONS

- A. Insulation in Wood Framed Exterior Walls: Batt insulation with integral vapor retarder.
 1. Wood Framed Wall Insulation: Minimum R-19 fiberglass batts with vapor retarder facing, fastened to wood studs, and greater thicknesses as required to fill framing cavity with insulation batt equal to full depth of framing member.
- B. Insulation in Interior Framed Walls: Unfaced Batt Insulation with no vapor retarder to full depth of framing member, at all wall locations.

2.03 BATT INSULATION MATERIALS

- A. Glass Fiber Batt Insulation: ASTM C 665; flexible preformed glass fiber batt; friction fit, sized to fit between framing elements, conforming to the following:
 1. Flame Spread Index: 25 or less, when tested in accordance with ASTM E84.
 2. Smoke Developed Index: 450 or less, when tested in accordance with ASTM E84.
 3. Combustibility: Non-combustible, when tested in accordance with ASTM E136, except for facing, if any.
 4. Formaldehyde Content: Zero.
 5. Thermal Resistance: R value 21.
 6. Facing: FSK (Foil-Scrim Kraft), one side. Exception: Paper facing may be provided in locations where the insulation is in "substantial contact" with the wall finish as described in exceptions noted in CBC 719.2.1.
 7. Maximum 0.50 perm rating, ASTM E 96.
 8. Manufacturers:
 - a. Johns Manville International, Inc: www.jm.com.
 - b. CertainTeed Corporation: www.certainteed.com.
 - c. Owens Corning Corp: www.owenscorning.com.
 - d. Substitutions: See Section 01 6000 - Product Requirements.
- B. Acoustic Batt (Sound Retardant) Insulation:
 1. Same as Batt Insulation, unfaced.

2.04 OTHER INSULATION

- A. Foamed-in-place Plastic Insulation: Polyurethane Foam Sealant, Flame Spread 20 / Smoke Developed 20, when tested in accordance with ASTM E 84.
 - 1. Manufacturers:
 - a. Dow Chemical Co.; Great Stuff: www.itsgreatstuff.dow.com. UL Listed R 13655.
 - b. Substitutions: See Section 01 6000 - Product Requirements.

2.05 ACCESSORIES

- A. Attachment clips as recommended by the manufacturer in writing.
- B. Tape: Bright aluminum self-adhering type, mesh reinforced, 2 inch wide.
- C. Insulation Fasteners: Impaling clip of unfinished steel with washer retainer and clips, to be adhered to surface to receive insulation, length to suit insulation thickness and substrate, capable of securely and rigidly fastening insulation in place.
- D. Nails or Staples: Steel wire; electroplated or galvanized; type and size to suit application.
- E. Adhesive: Type recommended by insulation manufacturer for application.

PART 3 EXECUTION

3.01 EXAMINATION

- A. Verify that substrate, adjacent materials, and insulation materials are dry and that substrates are ready to receive insulation.
- B. Verify that all framing inspections are complete and that required corrections have been made before installing insulation.

3.02 INSTALLATION - GENERAL

- A. Install insulation in accordance with manufacturer's instructions.
- B. Install in walls spaces without gaps or voids. Do not compress insulation.
- C. Trim insulation neatly to fit spaces. Fit insulation tight in spaces and tight to exterior side of mechanical and electrical services within the plane of insulation.
- D. Small gaps and voids which are not otherwise insulatable:
 - 1. Either sprayed foam type plastic insulation or mineral wool, as recommended by the Contractor and approved by the Architect.
 - 2. Provide bond breaking material between foam and adjacent materials wherever possible.
- E. Install with factory applied vapor retarder membrane facing warm side of building spaces.

3.03 BATT INSTALLATION

- A. Install insulation and vapor retarder in accordance with manufacturer's instructions.
- B. Install in exterior wall spaces without gaps or voids. Do not compress insulation.
- C. Trim insulation neatly to fit spaces. Insulate miscellaneous gaps and voids.
- D. Fit insulation tightly in cavities and tightly to exterior side of mechanical and electrical services within the plane of the insulation.
- E. Install with factory applied vapor retarder membrane facing warm side of building spaces. Lap ends and side flanges of membrane over framing members.

- F. Secure vapor barrier facing to framing along edges and at ends of batt at all applications. At horizontal applications additionally provide guy wire or netting to support insulation without sags.
- G. Batts: Attach by either method.
 - 1. Install as a single length between structural members or fold vapor barriers together and staple or tape at intermediate end joints.
 - 2. Staple or nail facing flanges in place at maximum 6 inches on center.
- H. Tape seal butt ends, lapped flanges, and tears or cuts in membrane.
- I. At wood framing, place vapor retarder on warm side of insulation by stapling at 6 inches on center. Lap and seal sheet retarder joints over member face.
- J. At metal framing, place vapor retarder on warm side of insulation; lap and seal sheet retarder joints over member face.
- K. Tape seal tears or cuts in vapor retarder.
- L. Extend vapor retarder tightly to full perimeter of adjacent window and door frames and other items interrupting the plane of the membrane. Tape seal in place.
- M. Acoustic Insulation: Place tightly within spaces, around cut openings, behind and around electrical and mechanical items within partitions, and tight to items passing through partitions.

3.04 PROTECTION

- A. Repair holes or tears with adhesive tape immediately before application of finish.
- B. Do not permit installed insulation to become wet or damaged prior to its concealment.

END OF SECTION

**SECTION 07 2129
SPRAYED INSULATION**

PART 1 GENERAL

1.01 SECTION INCLUDES

- A. Stabilized Cellulose insulation applied to underside of structure and attic framing cavities.

1.02 RELATED SECTIONS

- A. Section 07 2100 - Board and Batt Insulation.

1.03 REFERENCE STANDARDS

- A. ASTM C177 - Standard Test Method for Steady-State Heat Flux Measurements and Thermal Transmission Properties by Means of the Guarded-Hot-Plate Apparatus.
- B. ASTM C739 - Standard Specification for Cellulosic Fiber (Wood-Base) Loose-Fill Thermal Insulation.
- C. ASTM D1622/D1622M - Standard Test Method for Apparent Density of Rigid Cellular Plastics.
- D. ASTM E84 - Standard Test Method for Surface Burning Characteristics of Building Materials.
- E. ASTM E136 - Standard Test Method for Behavior of Materials in a Vertical Tube Furnace At 750 Degrees C.
- F. Title 24, Part 2, California Building Code (CBC), Sections 717 and 719.

1.04 SYSTEM DESCRIPTION

- A. Provide continuous thermal barrier for conditioned building enclosure.

1.05 SUBMITTALS

- A. See Section 01 3300 - Submittals, for submittal procedures.
- B. Product Data: Provide data on materials, describing insulation properties.
- C. Manufacturer's Installation Instructions: Indicate special procedures, perimeter conditions requiring special attention .
- D. Manufacturer's Certificate: Certify that Products meet or exceed specified requirements. Certify that products supplied contain no asbestos, fiberglass or other man-made fibers, ammonium sulfate-free. Provide copy of manufacturer's ISO 9001 certification.

1.06 QUALITY ASSURANCE

- A. Manufacturer Qualifications: Company specializing in manufacturing products specified in this section, with not less than ten years of documented experience. Manufacturer shall be ISO 9001 certified. Manufacturer shall subscribe to independent laboratory follow-up inspection services of Underwriter's Laboratories and each package of material shall be identified accordingly.
- B. Installer Qualifications: Company specializing in performing the work of this section with minimum five years of experience.
- C. Products listed and certified by Underwriter's Laboratories for applications indicated. Materials shall be tested in sprayed form and each package labeled with the test results.
- D. All products shall be 100% boric acid-based.
- E. Acceptable as fire blocking meeting CBC 717 per ICC ERS report.

1.07 DELIVERY STORAGE AND HANDLING

- A. Deliver materials in original unopened containers bearing the name of the manufacturer, product identification and references to specified testing.
- B. Store materials off ground, under cover and away from damp surfaces. Keep materials dry at all times.

1.08 FIELD CONDITIONS

- A. Do not install insulation, sealer when ambient and surface temperatures are lower than 65 degrees F.
- B. Maintain acceptable ambient and substrate surface temperatures prior to, during, and after installation of primer and insulation materials and overcoat.

1.09 PROJECT CONDITIONS

- A. Apply insulation after hangers and supporting clips are installed but before subsequent construction is erected.

PART 2 PRODUCTS

2.01 MANUFACTURERS

- A. Cellulose Fiber:
 - 1. Hamilton Manufacturing Corp; Product "ThermoLok": www.hmi-mfg.com. ICC ESR- 6094, specifically approved for overhead installation in floor/ceiling and roof/ceiling assemblies.
 - 2. Substitutions: See Section 01 6000 - Product Requirements.

2.02 MATERIALS

- A. Cellulose Fiber Insulation: ASTM C739; treated cellulose fiber, white color.
 - 1. K factor: 0.22 K, when tested in accordance with ASTM C 177. R value = 3.7 per inch.
 - 2. Density: 2 lb/cu ft, when tested in accordance with ASTM D1622/D1622M.
 - 3. NRC: 0.75 for 1 inch thickness.
 - 4. Moisture Absorption: Maximum 15 percent by weight.
 - 5. Flame Spread and Smoke Developed Index: 20/5, when tested in accordance with ASTM E84.
 - 6. Combustibility: Passing ASTM E136.
 - 7. Minimum 80% recycled wood-based material.
 - 8. Chemically treated with 100% boric acid-based additives for flame resistance and mold inhibition, not less than 23% by weight.
 - 9. No ammonium sulfate additives, no formaldehyde, phenetic resin, urea, or ammonium compounds.
 - 10. Impregnated with dry adhesives for self-supporting installation.

2.03 ACCESSORIES

- A. Primer: As required by insulation manufacturer.
- B. Laminated Containment Sheet: Foil-faced laminate kraft sheet material, formed and sized to restrain vertical, sloped and horizontal application of loose insulation materials, flame-retardant faced, Type recommended by Sheet Material Manufacturer to suit specific applications indicated. Product: "Lam-Tec", available from AFS, www.afs-foil.com, 909-390-5125.
 - 1. Surface Burning Characteristics: Flame spread/Smoke developed index of less than 25/50, when tested in accordance with ASTM E 84.
- C. Insulation Stop: Plastic, profiled and sized to suit rafter spacing and wall/sloped roof configuration.

- D. Fasteners, adhesives, sealing tapes and incidental materials necessary, as recommended by manufacturer, and as required for complete installation.

PART 3 EXECUTION

3.01 EXAMINATION

- A. Verify that surfaces are clean, dry, and free of matter that may inhibit adhesion. Examine surfaces and report unsatisfactory conditions in writing. Do not proceed until unsatisfactory conditions are corrected.
- B. Verify other work on and within spaces to be insulated is complete prior to application. Rough plumbing shall have passed required pressure tests.
- C. Verify spaces are unobstructed to allow placement of insulation.

3.02 PREPARATION

- A. Mask and protect adjacent surfaces from overspray or damage.
- B. Apply primer in accordance with manufacturer's instructions.
- C. Install insulation stops between rafters at wall/sloped roof construction to prevent insulation from covering soffit vents or from limiting air circulation from soffit to attic space.

3.03 INSTALLATION

- A. Install insulation in accordance with manufacturer's instructions. Apply materials using specially-designed nozzle at pressure recommended by manufacturer.
- B. Install insulation to a uniform monolithic density without voids.
- C. Do not exceed manufacturer's maximum recommended moisture content for insulation materials at time of insulation. Adjust water introduction rate during installation process to ensure proper water content.
- D. Remove materials exceeding maximum recommended moisture content. Do not allow wet insulation to remain in building cavities.
- E. Spray apply insulation materials to fill stud, joist and rafter spaces and other locations indicated or scheduled to a density of 2.7 lb.s/ cu. ft.
- F. Place against and behind mechanical and electrical services within the plane of insulation.
- G. Place against baffles, do not impede air flow in ventilated attics.
- H. Completely fill intended spaces, leave no gaps or voids.
- I. Screed and tamp wet insulation surface to improve adhesion and to achieve a smooth surface.
- J. Progressively install containment scrims or sheets to restrain loose insulation materials. Cut-out at locations of all electrical device boxes or other similar elements requiring plywood or gypsum board cut-outs.
- K. Install laminated containment sheet for insulation restraint in locations where insulation cannot be installed in accordance with CBC 719.4.
- L. Provide continuous ventilation as recommended by manufacturer to cure insulation. Do not install finish materials over insulation before curing is achieved.

3.04 CLEANING

- A. Remove insulation residue and protection materials.
- B. Sweep areas of work clean daily.

3.05 PROTECTION

- A. Do not permit subsequent construction work to disturb applied insulation.

3.06 SCHEDULES - BUILDINGS A & B

- A. Roof insulation to provide a complete insulation envelope surrounding all conditioned spaces, as indicated elsewhere in the Contract Documents, and as listed below:
 - 1. All Attic spaces and Roof Framing Cavities: Spray apply between rafters or ceiling joists to full depth of framing member, completely filling the void areas. Restrain all overhead sloped or horizontal applications with containment scrims or sheets, prior to installation of covering or finish materials specified in other sections.
- B. At locations where ceiling or wall finishes will not be in "substantial contact" with insulation, install laminated containment sheet covering insulation. Do not allow sprayed insulation to remain exposed.

END OF SECTION

SECTION 07 2500
WEATHER BARRIERS

PART 1 GENERAL

1.01 SECTION INCLUDES

- A. Water-Resistive Barrier: Under exterior wall cladding, over sheathing or other substrate; not air tight or vapor retardant.
- B. Air Barriers: Materials that form a system to stop passage of air through exterior walls, joints between exterior walls and roof, joints around frames of openings in exterior walls, and utility penetrations.

1.02 RELATED REQUIREMENTS

- A. Pertinent Sections specifying Volatile Organic Compound (VOC) Content Restrictions.
- B. Section 03300 - Cast-in-Place Concrete.
- C. Section 07 2100 - BOARD AND BATT BUILDING INSULATION: Vapor retarder installed in conjunction with batt insulation.
- D. Section 07 9200 - Joint Sealants: Sealing building expansion joints.

1.03 DEFINITIONS

- A. Weather Barrier: Assemblies that form either water-resistive barriers, air barriers, or vapor retarders.
- B. Vapor Retarder: Air tight barrier made of material that is relatively water vapor impermeable, to the degree specified, with sealed seams and with sealed joints to adjacent surfaces.
 - 1. Water Vapor Permeance: For purposes of conversion, $57.2 \text{ ng}/(\text{Pa s sq m}) = 1 \text{ perm}$.
- C. Water-Resistive Barrier: Water-shedding barrier made of material that is moisture resistant, to the degree specified, intended to be installed to shed water without sealed seams.

1.04 REFERENCE STANDARDS

- A. ASTM D1970/D1970M - Standard Specification for Self-Adhering Polymer Modified Bituminous Sheet Materials Used as Steep Roofing Underlayment for Ice Dam Protection.
- B. ASTM E 154 - Standard Test Methods for Water Vapor Retarders Used in Contact with Earth Under Concrete Slabs, on Walls, or as Ground Cover
- C. Manufacturer's recommendations and specifications.
- D. ASTM D 1709 - Standard Test Methods for Impact Resistance of Plastic Film by the Free-Falling Dart Method
- E. ASTM E96/E96M - Standard Test Methods for Water Vapor Transmission of Materials.
- F. ASTM E1643 Selection, Design, Installation, and Inspection of Water Vapor Retarders Used in Contact with Earth or Granular Fill Under Concrete Slabs.
- G. ASTM E1745 - Standard Specification for Plastic Water Vapor Retarders Used in Contact with Soil or Granular Fill under Concrete Slabs.
- H. ASTM E2178 - Standard Test Method for Air Permeance of Building Materials.
- I. ICC-ES AC38 - Acceptance Criteria for Water-Resistive Barriers; ICC Evaluation Service, Inc.
- J. California Code of Regulations, Title 24, Part 2, California Building Code (CBC), International Building Code, with California Amendments.

- K. California Code of Regulations, Title 24, Part 11 California Green Building Standards Code, "CAL-Green".

1.05 SUBMITTALS

- A. See Section 01 13300 - Submittals, for submittal procedures.
- B. Product Data: Provide data on material characteristics, performance criteria, and limitations.
- C. CAL-GREEN VOC Submittals: For adhesives sealants, fillers, coatings and primers, documentation including printed statement of VOC contents, comply with limits specified in related section.
- D. Below Grade Vapor Retarder Test Data: Submit independent third party test data for all listed performance values to show compliance with this specification. All test data for review shall be as published and released for publication by the authors without restriction of distribution.
1. Summary of test results as described in ASTM E 1745.
 - a. Certify that all mandatory ASTM E1745 testing has been performed on a single production roll per ASTM E1745 Section 8.1. Test reports must specifically state that sampling and testing of materials are in strict accordance with the requirements of the standard.
 2. Manufacturer's samples and literature.
 3. Manufacturer's installation instructions for placement, seaming and penetration repair instructions.
- E. Shop Drawings: For air-barrier and weather-resistive barrier assemblies; provide drawings of special joint conditions.
1. Show locations and extent of air barrier and weather-resistive barrier. Include details for substrate joints and cracks, counterflashing strips, penetrations, inside and outside corners, terminations, and tie-ins with adjoining construction.
 2. Include details of interfaces with other materials that form part of air barrier and weather-resistive barrier including related cladding, sealants and flashings.
 3. Provide project-specific details customized to this project's conditions. Manufacturer's standard details alone are not acceptable.
- F. Manufacturer's Installation Instructions: Indicate preparation, installation methods, and storage and handling criteria.
- G. Qualification Data: For Installer, Include list of ABAA-certified installers and supervisors employed by the Installer, who work on Project.

1.06 QUALITY ASSURANCE

- A. Installer Qualifications: An entity that employs installers and supervisors who are trained and approved by manufacturer.
1. Installer shall be licensed by ABAA according to ABAA's Quality Assurance Program and shall employ ABAA-certified installers and supervisors on Project.
- B. Preinstallation Conference: Conduct conference at Project site after approval of complete submittal to comply with requirements in Division 1 Section "Project Management and Coordination." Review requirements for air barrier, including surface preparation specified under other Sections, substrate condition and pretreatment, temporary weather protection, forecasted weather conditions, special details and sheet flashings, installation procedures, testing and inspection procedures, and protection and repairs.
1. Review air-barrier requirements and installation, special details, mockups, air-leakage and bond testing, air-barrier protection, and work scheduling that covers air barriers.

1.07 MOCK-UP

- A. Mockups: Build mockups to set quality standards for materials and execution and for preconstruction testing.
 - 1. Indicate portion of wall represented by mockup on Drawings or draw mockup as separate element.
 - 2. Build integrated mockups of exterior wall assembly 150 sq. ft. (14 sq. m), incorporating backup wall construction, external cladding, window, storefront, door frame and sill, insulation, ties and other penetrations, and flashing to demonstrate surface preparation, crack and joint treatment, application of air barriers, and sealing of gaps, terminations, and penetrations of air-barrier assembly.
 - a. Coordinate construction of mockups to permit inspection by Owner's testing agency of air barrier before external insulation and cladding are installed.
 - b. Include junction with roofing membrane, building corner condition, and foundation wall intersection.
 - c. If Architect determines mockups do not comply with requirements, reconstruct mockups and apply air barrier until mockups are approved.
 - d. Mock ups may be coordinated with mock ups required by other exterior material Sections, providing all provisions of this Section are met.
 - 3. Approval of mockups does not constitute approval of deviations from the Contract Documents contained in mockups unless Architect specifically approves such deviations in writing.

1.08 FIELD CONDITIONS

- A. Maintain temperature and humidity recommended by the materials manufacturers before, during and after installation.

PART 2 PRODUCTS

2.01 PERFORMANCE REQUIREMENTS

- A. VOC Limits for adhesives sealants, fillers and primers. Comply with limits specified in Section 01 6116.
- B. General: The air barrier assembly shall be capable of performing as a continuous vapor-permeable air barrier and as a liquid-water drainage plane flashed to discharge to the exterior incidental condensation or water penetration. Air-barrier assemblies shall be capable of accommodating substrate movement and of sealing substrate expansion and control joints, construction material changes, penetrations, tie-ins to adjacent waterproofing, and transitions at perimeter conditions without deterioration and air leakage exceeding specified limits.
- C. Air-Barrier Assembly Air Leakage: Less than 0.0008 cfm/sq. ft. of surface area at 1.57 lbf/sq. ft. (0.004 L/s x sq. m of surface area at 75 Pa), when tested according to ASTM E 2357.
- D. Building Envelope shall be constructed with a continuous air barrier to control air leakage into, or out of the conditioned space. An air barrier shall also be provided for interior partitions between conditioned space and space designed to maintain temperature or humidity levels which differ from those in the conditioned space by more than 50% of the difference between the conditioned space and design ambient conditions. The air barrier shall have the following characteristics:
 - 1. Continuous, with all joints made airtight.
 - 2. Capable of withstanding positive and negative combined design wind, fan and stack pressures on the envelope without damage or displacement, and shall transfer the load to the structure. It shall not displace adjacent materials under full load.
 - 3. Durable or maintainable.

4. The air barrier shall be joined in an airtight and flexible manner to the air barrier material of adjacent systems, allowing for the relative movement of systems due to thermal and moisture variations and creep. Connection shall be made between:
 - a. Foundation and walls.
 - b. Walls and windows or doors.
 - c. Different wall construction and cladding assemblies.
 - d. Wall and roof.
 - e. Wall and roof over unconditioned space.
 - f. Walls, floor and roof across construction, control and expansion joints.
 - g. Walls, floors and roof to utility, pipe and duct penetrations.
5. All penetrations of the air barrier and paths of air infiltration/exfiltration shall be made airtight.

2.02 WEATHER BARRIER ASSEMBLIES

- A. Water-Resistive Barrier: Provide on exterior walls under exterior cladding. Types specified in related sections specifying exterior cladding.
 1. Use building paper unless otherwise indicated.
 2. Under Portland cement stucco, use two separate layers of building paper.
 3. Under siding, use two separate layers of building paper.
- B. Air Barrier:
 1. On outside surface of sheathing of exterior walls use air barrier coating.

2.03 WATER-RESISTIVE BARRIER MATERIALS (NEITHER AIR BARRIER NOR VAPOR RETARDER)

- A. Building Paper: Asphalt-saturated Kraft building paper complying with requirements of ICC-ES AC308 Grade D.
 1. Water Resistance, ASTM D779: > 60 minutes.
 2. Water Vapor Transmission, ASTM E96, 11 perms (MVT).
 3. Manufacturers:
 - a. Fortifiber Building Systems Group; Super JumboTex 60 min., ICC ESR-1027: www.fortifiber.com.
 - b. Substitutions: See Section 01 6000 - Product Requirements.
 - a. Dryvit Systems, Inc.; Backstop NT: www.dryvit.com.

2.04 VAPOR RETARDER MATERIALS (AIR BARRIER AND WATER-RESISTIVE)

- A. Under-Slab Vapor Retarder/Barrier Sheet: 15 mil, single ply extruded polyolefin, ASTM E 1745, performance Classification A minimum. Products meeting Class B or C only are not acceptable.
 1. Water vapor permeance, ASTM E 154 or E 96 procedure B: 0.009 perm maximum.
 2. Tensile strength ASTM D 882 or ASTM E154, sec. 9; 45 lb/in.
 3. 0.01 or less perm vapor performance per ASTM E 154 Section 8, 11, 12 and 13; 0.0054 WVTR water vapor permeance per ASTM F 1249;
 4. Minimum puncture resistance, ASTM D 1709, Method B: 2200 grams.
 5. Products:
 - a. Epro Waterproofing Systems; ECOSHIELD-E15, 15-mil thick Sheet Membrane Vapor Retarder: www.eproserv.com.
 - b. Stego Industries, LLC, San Diego, CA; Stego Wrap Vapor Barrier, 15 mils: www.stegoindustries.com.
 - c. W.R Meadows, PERMINATOR, 15-mil thick, www.meadows.com.
 - d. REEF Industries, Inc., Griffolyn® Reinforced Vapor Protection, VAPORGUARD®, www.reefindustries.com.
 - e. Substitutions: See Section 01 6000 - Product Requirements.

- B. Adhesives, sealants and plastic cement: Types recommended by manufacturer to suit application and for compliance with referenced standards.
- C. Sealing Tape: Two-sided tape; 4 inch wide black seaming tape with release liner, perm rating not less than vapor retarder, complying with ASTM E 1643 – Standard Practice for Installation of Water Vapor Retarders Used in Contact with Earth or Granular Fill under Concrete Slabs; types recommended by manufacturer to suit application.
- D. Detail Tape and/or patch membrane for Concrete Adhesion:
 - 1. Type recommended by manufacturer tape and/or membrane detail strip and/or membrane to mechanically lock vapor retarder to concrete.
 - 2. Permeance: Comply with ASTM F1249.
 - 3. Peel Adhesion: Comply with PSTC 101
 - 4. Tensile Strength: Comply with ASTM E 154, Sec. 9
 - 5. Puncture Resistance: Comply with ASTM D 1709
 - 6. Product: Stego; Crete Claw Tape; www.stego.com.
- E. Vapor Retarder Stakes:
 - 1. Product: Vaporstake, LLC; Polyvinyl Black VaporStake™: www.vaporstake.com.
 - a. Solid Plastic construction: ASTM E1643-11 (sec. 8.4 & 8.6) and ACI 302.2R-06
 - b. Use with Vapor Retarders: ASTM E 1745-09
 - c. Recycled content: 100%
 - d. Size: Length for application and diameter recommended by manufacturer for application.

2.05 SEALANTS

- A. Single-Component, Nonsag, Neutral-Curing Silicone Joint Sealant: ASTM C 920, Type S, Grade NS, Class 100/50, for Use NT, complying with requirements of related Section 07 9005. Type as recommended by wall finish manufacturer for conditions indicated, and as required to maintain single-source warranty continuity.
 - 1. Color: As selected by Architect from manufacturer's standards.

2.06 ACCESSORIES

- A. Flexible Flashing: Self-adhesive sheet flashing complying with ASTM D1970/D1970M, except slip resistance requirement is waived if not installed on a roof.
 - 1. Products: By same manufacturer as air barrier coating, as recommended by manufacturer for specific application.
 - a. Dryvit Systems, Inc.; Aqua-Flash Detail Membrane: www.dryvit.com.
 - b. Grace Construction Products; Perma-Barrier Detail Membrane, Perma-Barrier Wall Flashing: www.grace.com.
 - c. Substitutions: See Section 01 6000 - Product Requirements.
- B. Thinners and Cleaners: As recommended by material manufacturer, meeting VOC requirements specified.
- C. Primers, Cleaners, and Other Sealant Materials: As recommended by sealant manufacturer, appropriate to application, and compatible with adjacent materials, meeting VOC requirements specified.
- D. Pre-molded Opening Corners: Size as required for snug fit at opening corners, resilient material compatible with related flexible flashings and air barriers, as recommended and manufactured by sheet material manufacturer.
 - 1. Grace Construction Products; "VYCORners" (pre-molded corners): www.na.graceconstruction.com,

PART 3 EXECUTION

3.01 EXAMINATION

- A. Verify that surfaces and conditions are ready to accept the work of this section.

3.02 PREPARATION

- A. Remove projections, protruding fasteners, and loose or foreign matter that might interfere with proper installation.
- B. Clean and prime substrate surfaces to receive sealants and fluid-applied membranes and self-adhered flashings in accordance with manufacturer's instructions.

3.03 INSTALLATION

- A. Install materials in accordance with manufacturer's instructions.
- B. Water-Resistive Barriers: Install continuous barrier over surfaces indicated, with sheets lapped to shed water but with seams not sealed.
- C. Vapor Retarders: Install continuous air tight barrier over surfaces indicated, with sealed seams and with sealed joints to adjacent surfaces.
- D. Apply sealants and adhesives within recommended application temperature ranges. Consult manufacturer if temperature is out of this range.
- E. Building Paper and Flashings for surfaces receiving Plaster Cladding or strip or panel siding:
 - 1. Cover surfaces of sheathed framed wall assembly with 2 layers of building paper, without holes, tears, or gaps. Apply building paper using single separate layer method. Secure end laps at supports.
 - 2. Attach to framed construction with fasteners extending through sheathing into framing. Space fasteners at 12 to 18 inches on center along each framing member supporting sheathing.
 - 3. Sequence work to ensure installation of papers continuously behind applied accessories.
 - 4. Lap horizontal edges 4-inches minimum, shingle fashion to weather.
 - 5. Lap vertical edges 6-inches minimum and seal with tape.
 - 6. Install water-resistive barrier over jamb flashings.
 - 7. Install air barrier and vapor retarder UNDER jamb flashings.
 - 8. Install head flashings under weather barrier.
 - 9. At openings to be filled with frames having nailing flanges, wrap excess sheet into opening; at head, seal sheet over flange and flashing.
 - 10. Double bottom layer at corners, extending 6-inches around corner from each side.
 - 11. Lap sheet metal and flexible flashings. Lap felt flashing strips at door frames and windows; lap over head and jamb strips and under sill strip.
 - 12. Coordinate installation with related section to ensure that no part of metal lath specified in related sections extends under paper or flashing. Weather all laps to exterior.
- F. Flexible Flashing: Install in at opening flashings, at locations indicated and underlying horizontal and sloped areas of plaster cladding, in inset wall opening sills and similar locations; in accordance with the manufacturer's recommendations and as follows;
 - 1. Substrate Preparation:
 - a. Smooth, clean, dry and free of voids, spalled areas, loose substrate, loose nails, sharp protrusions or other matter that will hinder the adhesion or regularity of installation.
 - b. Clean loose dust or dirt by wiping with a clean dry cloth or brush. Prime substrate with compatible primer in conditions recommended by flashing manufacturer.
 - 2. Flashing Application:

- a. Coordinate installation with other paper and metal flashings, interleave as required to weather all laps to drain, directing water to exterior.
 - b. Coordinate installation with window and insert opening frames.
 - c. Peel release paper from roll to expose adhesive surface and position flashing to center over joint location before application. Ensure flashing is centered over joint opening. Avoid fishmouths.
 - d. Press flashing firmly into place and hand-roll with resilient roller. Ensure full, continuous and intimate contact with the substrate. Cut out wrinkles or other affected areas and replace with smooth flat membrane.
 - e. Flashing shall be continuously supported by the substrate without spanning or bridging joints, gaps or voids in excess of 1/4 inch. Minimum End Laps 2 inch.
3. Leave flexible flashing in condition to receive installation of metal lath at locations to receive plaster cladding.
 4. Preformed Resilient Corners: Provide at all lower corner openings of windows unless metal sill pan flashings are shown on the drawings.
- G. Openings and Penetrations in Exterior Weather Barriers:
1. Install flashing over sills, covering entire sill frame member, extending at least 5 inches onto weather barrier and at least 6 inches up jambs; mechanically fasten stretched edges.
 2. Lap sheets shingle-fashion to shed water and seal laps air tight.
 3. Once sheets are in place, press firmly into substrate with resilient hand roller; ensure that all laps are firmly adhered with no gaps or fishmouths.
 4. At openings to be filled with frames having nailing flanges, seal head and jamb flanges using a continuous bead of sealant compressed by flange and cover flanges with at least 4 inches wide; do not seal sill flange.
 5. At openings to be filled with non-flanged frames, seal weather barrier to all sides of opening framing, using flashing at least 9 inches wide, covering entire depth of framing.
 6. At head of openings, install flashing under weather barrier extending at least 2 inches beyond face of jambs; seal weather barrier to flashing.
 7. At interior face of openings, seal gap between window/door frame and rough framing, using joint sealant over backer rod.
 8. Service and Other Penetrations: Form flashing around penetrating item and seal to weather barrier surface.

3.04 INSTALLATION- VAPOR RETARDER UNDER CONCRETE SLAB-ON-GRADE

- A. Install materials in accordance with manufacturer's instructions and ASTM E 1643-98.
1. Unroll Vapor Retarder membrane with the longest dimension parallel with the direction of the concrete pour.
 2. Extend vapor barrier over footings and grade beams to a distance acceptable to the structural engineer or stop at impediments such as dowels and waterstops.
 3. Seal vapor barrier to footing/grade beam with double sided tape, termination bar, or both.
 4. Lay-out sheets to minimize quantity of joints.
 - a. Lap edge 6 -inches minimum and end joints 12 -inches minimum and continuously seal with joint tape.
 5. Apply tape to a clean and dry vapor retarder membrane.
 6. Terminate vapor retarder membrane per manufacturer's recommendations along perimeter; at footers, vertical walls, and against penetrations.
 - a. Seal perimeter with continuous mastic bead along foundation walls.
 - b. Seal barrier joints with tape.
- B. No penetration of the Vapor Retarder membrane is allowed except for reinforcing steel and permanent utilities.

1. Seal all penetrations (including pipes) with field-assembled boots per manufacturer's instructions.
2. Where forms are used, provide Vapor Stakes to hold forms in place.
 - a. Penetrate vapor Retarder with stake.
 - b. Treat stake as pipe penetration.
 - c. Leave stake permanently in concrete.
 - d. Using a power saw, cut the stake off above the seal, but below the concrete finished surface not higher than elevation of horizontal reinforcing.
 - e. The lower portion of the vapor stake remains in place, permanently plugging the penetration.
- C. Refer to Section 03 3000 "Cast-in-Place Concrete" for installation coordination requirements.
- D. Repair damaged areas by cutting patches of Vapor Barrier/Retarder, overlapping damaged area 6 - inches and taping all four sides with tape.
 1. Do not use concrete adhesion tape to repair penetrations.
- E. Where differential settlement is possible, adhere the vapor retarder at building perimeter and in a grid pattern every 4 -feet on-center with integrally bonded detail tape for concrete adhesion.

3.05 PROTECTION

- A. Protect under-slab vapor retarder sheets from puncture during installation. Patch punctures before proceeding with subsequent construction.
 1. NOTE: SCREEDING STAKES DRIVEN THROUGH RETARDER must be repaired per membrane manufacturer's recommendation.
- B. Install runway planks in construction traffic lanes until slabs are poured.

3.06 FIELD QUALITY CONTROL

- A. See Section 01 4000 - Quality Requirements, for additional requirements.
- B. Obtain approval of installation procedures by the weather barrier manufacturer based on a mock-up installed in place, prior to proceeding with remainder of installation.
- C. Under-slab Vapor Retarder Membrane: Conduct a visual inspection, in the presence of the Architect/Engineer, of the entire Retarder installation the day before pouring concrete. Make all necessary corrections prior to placing concrete.
- D. Take digital photographs of each portion of the installation prior to covering up.

3.07 PROTECTION

- A. Do not leave materials exposed to weather longer than recommended by manufacturer.
- B. Do not leave paper- or felt-based barriers exposed to weather for longer than one week.

END OF SECTION

SECTION 07 2633

WATER VAPOR EMISSION CONTROL COATING

PART 1 GENERAL

1.01 SUMMARY

- A. Epoxy type, environmentally safe, 100 percent solids, water vapor emission and alkalinity control coating. A Moisture Mitigation and Alkalinity Control System as defined in ASTM F3010.
- B. Cementitious leveling underlayment applied over moisture mitigation coating as required by specific flooring adhesive to be used at each finish flooring condition.
 - 1. Coordinate all flooring manufacturers adhesive requirements for submitted flooring materials in each area to determine requirements for flooring adhesive underlayments.

1.02 RELATED REQUIREMENTS

- A. Section 01 4000 "Quality Requirements" for product manufacturer's independent laboratory qualifications.
- B. Section 01 6116 "VOC Restrictions".
- C. Section 03 3000 "Cast-in-Place Concrete" for Concrete slab substrate.
- D. Division 09 Section specifying concrete floor surface preparation.
- E. Division 09 Section specifying floor moisture and pH testing.
- F. Division 09 Floor Covering Sections, for installation requirements and to verify compatibility with the floor covering manufacturer's adhesives.

1.03 REFERENCED STANDARDS

- A. California Code of Regulations, Title 24, Part 2, California Building Code (CBC), International Building Code, with California Amendments.
- B. California Code of Regulations, Title 24, Part 11 California Green Building Standards Code, "CAL-Green".
- C. American Concrete Institute:
 - 1. ACI 318 - Building Code Requirements for Structural Concrete.
- D. ASTM International:
 - 1. ASTM C109 - Standard Test Method for Compressive Strength of Hydraulic Cement Mortars (Using 2-in. Cube Specimens).
 - 2. ASTM D1308 - Standard Test Method for Effort of Household Chemicals on Clear and Pigmented Organic Finishes.
 - 3. ASTM D1653-03(2008) Standard Test Methods for Water Vapor Transmission of Organic Coating Films
 - 4. ASTM D7234-12 - Standard Test Method for Pull-Off Adhesion Strength of Coatings on Concrete Using Portable Pull-Off Adhesion Testers
 - 5. ASTM E96 - Standard Test Methods for Water Vapor Transmission of Materials.
 - 6. ASTM E1155 Standard Test Method for Determining FF Floor Flatness and FI Floor Levelness Numbers
 - 7. ASTM F2170-09 Standard Test Method for Determining Relative Humidity in Concrete Floor Slabs Using in situ Probes.
 - 8. ASTM F3010 - 13 Two-Component Resin Based Membrane-Forming Moisture Mitigation Systems for Use Under Resilient Floor Coverings.

- E. International Concrete Repair Institute (ICRI) Guideline No. 03732- Selecting and Specifying Concrete; Surface Preparation for Sealers, Coatings and Polymer Overlays.
- F. EPA Method 24 VOC Content Testing.

1.04 DEFINITIONS

- A. Water Vapor Emission Control Coating (Moisture Mitigation Control System): A sequence of products applied on a concrete floor to isolate moisture and high pH in the concrete from adhesive and finish floor covering.
- B. Water Vapor Emission Control Barrier: Coating applied on concrete floor that acts as the primary barrier to moisture movement.
- C. Underlayment: Trowelable or pourable cementitious patching/leveling compounds to which the finish floor covering is adhered. Underlayment is installed on top of the Water Vapor Emission Control Barrier.

1.05 SUBMITTALS

- A. General: Submit in accordance with Section 01 3300.
- B. Provide complete submittals at the same time as submittals for work in related sections to permit review of complete and integrated systems and assemblies.
- C. Product Data: For each type of product indicated, demonstrate compliance with specified attributes.
 - 1. Include detailed installation requirements, spread rates, joint and crack treatment and final barrier surfaces for floor coverings.
 - 2. ASTM Reports: Certified laboratory reports for specified ASTM performance.
 - 3. Extended Warranty Certificate: Manufacturers standard 15 year warranty for manufacturing defects and on site material performance. Warranty shall not list ACI-318 compliance exclusions.
 - 4. Pail Labels: Collect and submit each original pail label of Water Vapor Emission Control Coating installed. Copies are not acceptable. If pail labels are not removable, provide pails.
- D. Quality Control Post-Testing: Tensile pull-off testing results per ASTM D7234 performed by Owner's Testing Agency prior to floor covering installation.
- E. CAL-GREEN Submittals: Product Data - VOC Limits: For adhesives sealants, fillers, primers and coatings, documentation including printed statement of VOC contents, comply with limits specified in related section.
- F. Shop Drawings: Floor Plans, indicating areas of installation, sequencing, and total area of installation in square feet.
- G. Manufacturer Certification: Provide letterhead documentation of complete review of concrete mix designs, admixtures, sub-slab vapor retarder installation and curing methods with written acceptance prior to installation.
- H. Installer Proof of Qualification: Factory licensed, approved or certified applicator certificate signed by the manufacturer.

1.06 QUALITY ASSURANCE

- A. Manufacturer Qualifications: Manufacturer shall have not less than five years experience in manufacturing floor moisture mitigation systems. The products shall be specifically formulated and marketed to reduce concrete floor moisture vapor interaction with resilient floor coverings and for pH control.

- B. Installer Qualifications: Installer shall have not less than five years experience installing the selected fluid based coating systems, shall be trained by the manufacturer, experienced in surface preparation and application of the material and shall be subject to inspection and control by the manufacturer.
- C. Pre-installation Testing:
 - 1. Document floor and building conditions are within acceptable limits of temperature, relative humidity, and concrete condition before proceeding with product application.
 - 2. File a pre-installation checklist with the manufacturer and receive written confirmation of approval to proceed to support manufacturer's 10-year warranty.
- D. Product Performance:
 - 1. Manufacturer shall provide independent laboratory test reports documenting the following:
 - a. Water vapor transmission by ASTM E96 (water method) or ASTM D1653 indicating a maximum 0.1 perms net for coating on concrete.
 - b. Warrant no loss in moisture-resistance properties for a period of ten years of exposure to continuous water contact and pH greater than 10 after final cure.
- E. Mock-Up: Provide a mock-up for evaluation of surface preparation techniques and moisture mitigation system application workmanship.
 - 1. Mockup area of at least 200 sq ft in location approved by Architect / Owner.
 - 2. Do not proceed with work until mockup workmanship and underlayment surface appearance are approved by manufacturer's representative and Owner's representative.
 - 3. Mockup bond tests: Owner's Testing Agency will perform tensile bond tests in triplicate on mockup, no sooner than 72 hours after installation is completed, according to ASTM D7234 through entire Water Vapor Emission Control Coating into concrete substrate. Comply with the following:
 - a. No cohesive failure of leveling underlayment with at least 200 psi, or tensile failure in concrete substrate with no inter-layer or intra-layer failure of Water Vapor Emission Control Coating.
 - b. If failure occurs, determine cause and method(s) to avoid further unacceptable work. Remove and re-apply mock-up area as required to produce acceptable work. Do not proceed with installation of Water Vapor Emission Control Coating until bond test results meet requirements above and are acceptable to Water Vapor Emission Control Coating manufacturer.

1.07 DELIVERY, STORAGE, AND HANDLING

- A. Deliver products to the job site in their original unopened containers, clearly labeled with the manufacturer's name and brand designation.
- B. Store products in an approved ventilated dry area; protect from dampness, freezing, and direct sun light. Do not store in areas with temperatures in excess of manufacturer's written instructions.
- C. Handle product in a manner that will prevent breakage or leakage of containers and damage to products.
- D. Use products before manufacturer's expiration dates.

1.08 PROJECT CONDITIONS

- A. Maintain environmental conditions (temperature, humidity, and ventilation) within limits required by moisture mitigation system manufacturer. Do not install products under environmental conditions outside manufacturer's limits.
- B. Do not apply Water Vapor Emission Control Coating to unprotected surfaces or when moisture is present on the surface of the concrete.

- C. Do not apply Water Vapor Emission Control Coating when air or floor temperature is lower than 50 degrees F (10 degrees C) or expected to fall below this temperature within 24 hours from time of application.
- D. Install Water Vapor Emission Control Coating only when concrete floor surface temperature is a least 5 degrees Fahrenheit above the dewpoint temperature of the air over the floor. Maintain and document coated floor surface temperature at least 5 degrees Fahrenheit above air dewpoint temperature for at least 24 hours after application.
- E. Provide continuous ventilation and air movement at all times during application and curing process of the moisture mitigation system.
- F. Protect work to prevent damage that will affect performance and the finished underlayment surface.

1.09 WARRANTY

- A. Extended Warranty: Warranty shall provide, at Owner's option, repair or replacement of the Water Vapor Emission Control Coating and flooring damaged due to failure of the Water Vapor Emission Control Coating during the warranty period. Warranty definition of damage shall include at least the following:
 - 1. Distress of flooring caused by moisture including but not limited to
 - a. Adhesive deterioration resulting in loss of flooring bond to the floor;
 - b. Formation of bubbles, mole trails, lumps, bumps, seam separation, or other significant displacement that interferes with the intended use of the flooring;
 - 2. Distress of the Water Vapor Emission Control Coating including but not limited to
 - a. Deformation of patching/leveling compounds installed under the Water Vapor Emission Control Coating;
 - b. Adhesive or cohesive failure of Water Vapor Emission Control Coating components;
 - c. Distress of underlayment above the Water Vapor Emission Control Coating such as delamination, disbanding, expansion, chemical reaction, or other deformation or displacement that interferes with the intended use of the flooring.
- B. Water Vapor Emission Control Coating Warranty coverage shall commence on the date of completion of flooring installation.
- C. Warranty shall include the replacement of Water Vapor Emission Control Coating, flooring system, patching compounds, installation accessories flooring materials and labor costs.
 - 1. Warranty shall not exclude or become void due to non-conformance to ACI-318 parameters, dew-point, concrete salts, admixtures, resin and silicate surface treatments or cohesive substrate failure in the concrete surface due to normal concrete movement. Installation of Water Vapor Emission Control Coating indicates acceptance of site conditions.

PART 2 PRODUCTS

2.01 SYSTEM DESCRIPTION

- A. Comply with product requirements of ASTM F3010: Non-corrosive, low viscosity, high gloss, microbial resistant, moisture-alkaline resistant coating to suppress, control and mechanically restrict water emission and pH level of concrete substrates for compliance with subsequent floor coverings or coating materials.
- B. Coating product must contain 100% epoxy resin solids. Products based on silicate chemistry, potassium, sodium, lithium, and similar formulations, water-based acrylics, or resin formulations containing or mixed with water, are not acceptable and will be rejected.

- C. Barrier Coating Requirements: It is the intent of this section and the drawings to require a complete barrier system. Any items not specifically noted but necessary for a complete barrier system shall be provided under this section.
 - 1. Coating shall be compatible with all types of floor covering products, no system failures due to improper installations and contain no water/alkaline soluble compounds.
 - 2. Coating shall have a sufficient density to reduce water vapor transmission, avoid water vapor damage to other adhered systems and resistant to most commonly encountered acids/solvents in case of topical exposure (spills).
 - 3. Coating shall be resistant to mold, mildew and biological growth when applied to prepared substrates

2.02 PERFORMANCE REQUIREMENTS

- A. Moisture and Alkalinity: Barrier shall remain tolerant to alkalinity of 14 pH per ASTM D1308 and to 100% relative humidity per ASTM F2170.
- B. Water Vapor Transmission:
 - 1. Manufacturer shall provide independent laboratory test reports documenting the following:
 - a. Water vapor transmission by ASTM E96 (water method) or ASTM D1653 indicating a maximum 0.1 perms net for coating on concrete.
 - b. Warrant no loss in moisture-resistance properties for a period of fifteen years of exposure to continuous water contact and pH greater than 8 after final cure.

2.03 WATER VAPOR EMISSION CONTROL COATING

- A. Source Limitations: Provide materials approved by one Water Vapor Emission Control Coating manufacturer including moisture-resistant concrete patching and leveling compounds for use under Water Vapor Emission Control Coating, primers, coatings, sand, and underlayment leveling/patching compounds.
- B. Basis of Design: VAP I 2000 Zero VOC family of products by Koster Waterproofing Systems. Subject to compliance with requirements specified in this section, provide one of the following products:
 - 1. VAP I 2000 Zero VOC family of products by Koster Waterproofing Systems, www.kosterusa.com.
 - a. VAP I 2000 Zero VOC, twelve hour cure time to final flooring.
 - b. VAP I 2000 FS (Fast Set); four hour cure time to final flooring.
 - c. VAP I 2000 UFS (Ultra Fast Set); two hour cure time to final flooring.
 - 2. A C Tech ® 2170 FC ZERO System: by Allied Construction Technologies, Inc. www.actamerican.net, www.combimix.com.
 - 3. VaporTight SG3 by Aquafin, www.aquafin.net.
 - 4. MC™ RAPID by Ardex, www.ardexamericas.com.
 - 5. Substitutions: See Section 01 6000.
- C. Single Coat System: 2-component, VOC Compliant, 100% solids epoxy formulated as a vapor barrier against high moisture and alkalinity in concrete substrates. Apply at manufacturer's recommended rate, minimum average 15-mils (0.015-in.), to provide maximum 0.1 net perms (grains/hr/sq ft/in. Hg) water vapor transmission.
 - 1. Floor preparation in compliance with coating manufacturers written requirements and meeting warranty criteria.
 - 2. Manufacturer's approved bonding agent/primer
 - 3. Moisture Mitigation System Control Coating: Apply a single coat at manufacturer's recommended and tested coverage rate, minimum average to provide maximum 0.1 net perms (grains/hr/sq ft/per 1-inch Hg) water vapor transmission.
 - 4. Cementitious Leveling Underlayment: Manufacturer's approved.

- D. Water Vapor Emission Control Coating: Epoxy resins and other chemical compounds; 100 % solids, specifically formulated chemicals and resins to provide the following properties. Coating product must contain 100% epoxy resin solids.
1. Solid Content: 100%.
 2. VOC, mixed: 0 g/L.
 3. Flash Point: 200° F.
 4. Perm Rating, ASTM E96: Not to exceed 0.1 grains/ sq.ft. /hour in Hg.
 5. ASTM E 96, Water Vapor Transmission (wet methods) Performance shall be documented by an independent testing laboratory at a minimum 97% for water vapor transmission reduction compared to untreated concrete.
 6. ASTM D 1308; Insensitivity to alkaline environment up to, and including, pH 14 in a 14 day bath test.
 7. Certify acceptance and exposure to continuous topical water exposure after final cure.
 8. System must be able to perform as required with ASTM F2170 RH Probe readings of 100%.
- E. Expansion Joint Treatment: By Coating manufacturer or approved by coating manufacturer and type recommended to suit site conditions.
1. Basis of Design for KOSTER system: KOSTER Joint Sealant FS-H.
- F. Non-Moving Crack Treatment: By Coating manufacturer or approved by coating manufacturer and type recommended to suit conditions indicated.
1. Basis of Design for KOSTER system: KOSTER TA mixed with KOSTER VAP I 2000.
- G. Self-Leveling Primer: By Coating manufacturer or approved by coating manufacturer and type recommended to suit site conditions.
1. Basis of Design for KOSTER system: KOSTER VAP I® 06 Primer.
 2. Application: Applied over Moisture Mitigation System Coating Control System coating prior to installation of Underlayment.
- H. Patching / Leveling Compounds: Formulated primarily of calcium aluminate or portland hydraulic cements, minimum compressive strength 3,000 psi at 28 days when tested in accordance with ASTM C109. Patching / Leveling compounds that rely primarily on gypsum for their cementing properties shall not be used.
1. By Coating manufacturer or approved by coating manufacturer and type recommended to suit site conditions.
 2. Basis of Design for KOSTER system: KOSTER SL, Cementitious Underlayment.
- I. Surface treatment for concrete contaminated with Soluble Silicates: By Coating manufacturer or approved by coating manufacturer and type recommended to suit conditions indicated.
1. Basis of Design for KOSTER system: KOSTER IB.
 2. Application: Apply to contaminated concrete prior to Moisture Mitigation System Coating Control System Sealer application.

PART 3 EXECUTION

3.01 EXAMINATION

- A. Site Verification: Verify substrate conditions are acceptable for a warranted system.
- B. Verify new concrete floors have cured minimum 28 days.
- C. Verify concrete cleaned by shot blasting or other mechanical abrasion as specified in related section to an ICRI CSP-3 to CSP-4 profile and is not excessively rough for sealing at specified moisture mitigation coating application rates.
 1. Verify removal of dirt, oils, films, and other materials detrimental to sealer application.

- D. Examine substrates, with Installer present, for compliance with requirements for surface contamination, damage, and other conditions affecting performance of the Work.
- E. Examine substrate to determine repairs required to restore substrate surface to be within tolerances required for floor finishes specified in other sections, prior to completing Work of this section.
- F. Examine substrate to verify surfaces prepared in accordance with this section will be suitable for application of finishes specified in other sections.
- G. Prepare written report, endorsed by Installer, listing conditions detrimental to performance with recommendations for methods and materials required to correct conditions before proceeding with work of this section.
- H. Proceed with surface preparation only after unsatisfactory conditions have been corrected.
 - 1. Proceeding with surface preparations indicates acceptance and of surfaces and conditions of substrate.
- I. Verify items which penetrate concrete substrate to receive coating are securely installed and coating installation will not affect proper installation and warranty requirements.
- J. Surfaces shall be free of water, rain, snow and frost.

3.02 PREINSTALLATION TESTING

- A. Moisture and pH Testing: As specified in related Section 09 0512.
- B. Verify relative humidity testing in accordance with ASTM F2170 and alkalinity-pH testing is completed using methods specified and acceptable results obtained.

3.03 PREPARATION

- A. Surface Preparation: As specified in related Section 09 0511.
- B. Protection: Mask and protect walls, equipment from adjacent work and finishes during installation process.
- C. Concrete Fiber Reinforcement, if present after shot blasting, shall be burned off, scraped and vacuumed, leaving no fibers protruding from the concrete surface.
- D. Cleaning: Broom-sweep and vacuum slab surfaces to remove contaminants.
- E. Do not acid etch surface. Do not apply water to surface.
- F. Joints and Cracks: Fill cracks, construction joints, sawcut control joints, and surface irregularities with crack repair compound.
 - 1. Route cracks with 4 to 6-inch diameter x 0.060-inch diamond abrasive wheel to not more than 1-1/8 to 1-1/4-inch depth. Clean by vacuum to remove dust and residue.
 - 2. Mix and apply crack repair compound according to manufacturer's instructions using gravity feed.
 - 3. Fill cracks to within 1/8-inch. of surface, add sand and apply additional crack repair compound to saturate sand and slightly overfill crack.
 - 4. Scrape or lightly grind flush after curing to provide a level surface for Water Vapor Emission Control Coating.
 - 5. Fill cracks completely to stabilize against concrete movement and to provide moisture barrier.

3.04 INSTALLATION

- A. Apply Water Vapor Emission Control Coating where relative humidity and alkalinity tests do not meet flooring manufacturers requirements for floor finishes:

- B. Apply Water Vapor Emission Control Coating based on relative humidity and alkalinity test results in strict compliance with the manufacturer's written instructions.
- C. Water Vapor Emission Control Coating System Application:
 - 1. Coverage rates are dependent on the surface texture and porosity of the substrate.
 - 2. Apply sufficient coating to achieve the manufacturer's recommended minimum film thickness using manufacturer's recommended squeegee or roller. Periodically check application rate and wet film thickness. Follow manufacturer's recommended curing times.
 - 3. Two-coat system: Apply sand broadcast to rejection into second coat according to manufacturer's written instructions. After curing, remove excess sand by sweeping and vacuuming.
- D. Cementitious Underlayment System:
 - 1. Self-Leveling Cementitious Underlayment:
 - a. One-coat Water Vapor Emission Control Coating without sand broadcast, apply primer to coating. Do not exceed manufacturer's recommended application rate and film thickness. Thicker primer can lead to cracking of underlayment. Allow manufacturer's specified cure time. Do not exceed manufacturer's specified open time. Mix and pour the underlayment product on the floor and disperse with the approved spreader, followed by smoothing the material with the approved smoother. Wear cleated shoes to avoid leaving marks.
 - b. Do not exceed maximum application thickness specified by underlayment manufacturer. Provide a smooth, uninterrupted, level finish without bumps, clumps, depressions, or other defects that would reflect through flooring.
 - c. Floor finish shall be flat to within 1/8-inch. in 10 ft, and as measured by ASTM E1155. Provide Ff of 50 and Fl of 30.
 - 2. Inspect and Repair defects:
 - a. Inspect hardened underlayment for flatness.
 - b. Lightly sand flat any bumps in the underlayment. Unhydrated or partially hydrated clumps of underlayment cement shall be removed by carefully chiseling and patching with compatible trowel-applied patching compound recommended by underlayment manufacturer. Do not penetrate the moisture mitigation coating.
 - c. Fill low spots with compatible trowel-applied patching compound recommended by underlayment manufacturer. Sand smooth to remove trowel marks.
- E. Allow surfaces to cure and re-apply additional coats as required to form a uniform control layer.

3.05 FIELD QUALITY CONTROL

- A. Manufacturer and installer to guarantee installed Water Vapor Emission Control Coating is compatible with all specified floor coverings.
- B. Post-Installation Testing: Owner's Testing Agency to perform the following testing:
 - 1. Tensile bond tests: Perform tensile bond tests in triplicate, at the same rate as Relative Humidity testing specified in related section, no sooner than 72 hours after installation is completed, according to ASTM D7234 through entire Water Vapor Emission Control Coating into concrete substrate. Comply with the following:
 - a. No cohesive failure of leveling underlayment with at least 200 psi, or tensile failure in concrete substrate with no inter-layer or intra-layer failure of Water Vapor Emission Control Coating.
 - 2. Repair failed test locations at no cost to Owner and re-test to demonstrate compliance.

3.06 PROTECTION

- A. Protect each coat from damage due to traffic, topical water and contaminants during required cure period until acceptance by related floor covering section.

END OF SECTION

SECTION 07 4113
METAL ROOF PANELS

PART 1 GENERAL

1.01 SECTION INCLUDES

- A. Architectural roofing system of preformed steel panels.
- B. Attachment system.
- C. Finishes.
- D. Accessories and miscellaneous components: Flashings, fasteners, and accessories as required for weatherproof installation.

1.02 RELATED REQUIREMENTS

- A. Pertinent Sections specifying Volatile Organic Compound (VOC) Content Restrictions.
- B. Section 06 1000 - Rough Carpentry: Roof sheathing.

1.03 REFERENCE STANDARDS

- A. ASTM A792/A792M - Standard Specification for Steel Sheet, 55% Aluminum-Zinc Alloy-Coated by the Hot-Dip Process.
- B. ASTM D1970/D1970M - Standard Specification for Self-Adhering Polymer Modified Bituminous Sheet Materials Used as Steep Roofing Underlayment for Ice Dam Protection.
- C. ASTM E96/E96M - Standard Test Methods for Water Vapor Transmission of Materials.
- D. ASTM E1646 - Standard Test Method for Water Penetration of Exterior Metal Roof Panel Systems by Uniform Static Air Pressure Difference.
- E. ASTM E1680 - Standard Test Method for Rate of Air Leakage Through Exterior Metal Roof Panel Systems.
- F. California Code of Regulations, Title 24, Part 2, California Building Code (CBC), International Building Code
- G. California Code of Regulations, Title 24, Part 11 California Green Building Standards Code, "CAL-Green".
- H. Sheet Metal and Air Conditioning Contractors National Association: "Architectural Sheet Metal Manual".
- I. UL 580 - Standard for Tests for Uplift Resistance of Roof Assemblies.

1.04 SUBMITTALS

- A. General: Submit in accordance with Section 01 3300.
- B. Product Data: For each type of product indicated, demonstrate compliance with specified attributes. Manufacturer's data sheets on each product to be used, including:
 - 1. Summary of test results, indicating compliance with specified requirements.
 - 2. Storage and handling requirements and recommendations.
 - 3. Installation methods.
 - 4. Specimen warranty.
- C. CAL-GREEN Submittals: Product Data.

1. VOC Limits: For adhesives sealants, fillers, primers and coatings, documentation including printed statement of VOC contents, comply with limits specified in related section.
 2. Product Test Reports: For roof materials, indicating that roof materials comply with Solar Reflectance Index requirement and demonstrate Cool Roof Rating Council (CRRC) listing.
- D. Shop Drawings: Include layouts of roof panels, details of edge and penetration conditions, spacing and type of connections, flashings, underlayments, details of trim, gutter, ridge, curved panel and flashing conditions, fastening and anchorage methods, weatherproofing techniques, terminations, and flashing of each type of penetrations, and special conditions.
1. Show work to be field-fabricated or field-assembled.
 2. Include structural analysis signed and sealed by qualified structural engineer, indicating conformance of roofing system to specified loading conditions.
 3. Indicate metal thickness and finishes, panel lengths, joining details, anchorage details, flashings and special fabrication provisions for termination and penetrations; purlin and girt locations, thermal expansion provisions and special supports.
 4. Include roof plan showing clip spacing at ridge, eave and field.
 5. Indicate relationships with adjacent and interfacing work. Demonstrate continuity of air barriers with related wall assemblies and roof underlayment.
 6. Shop drawings must be completed by the metal roof panel manufacturer's engineering department.
 7. All changes recommended by Contractor must be approved by the manufacturer in writing prior to submittal.
- E. Selection Samples: For each roofing system specified, submit color chips representing manufacturer's full range of available colors and patterns.
- F. Verification Samples: For each roofing system specified, submit samples of minimum size 12 inches square, representing actual roofing metal, thickness, profile, color, and texture.
1. Include typical panel joint in sample.
 2. Include typical fastening detail.
- G. Warranty: Submit specified manufacturer's warranty and ensure that forms have been completed in Owner's name and are registered with manufacturer.

1.05 INFORMATIONAL SUBMITTALS

- A. Delegated-Design Submittal: For metal roofs indicated to comply with performance requirements and design criteria, substantiating system performance, structural capacity, anchorages and fasteners sizes and spacings per specified criteria, including analysis data signed and sealed by the qualified professional engineer responsible for their preparation.
1. Detail fabrication and anchorage of metal roofs.
 2. Include design calculations.
 3. Provide clip fastener pull-out test report and calculations.
- B. Qualification Data: For qualified Installer and testing agency.
- C. Professional Engineer Qualifications: Demonstrate compliance with specified requirements.
- D. Preconstruction Test Reports: For sealant.
- E. Product Test Reports: Based on evaluation of comprehensive tests performed by a qualified testing agency, indicating compliance with performance requirements. For each system provide test reports with shop drawings.
- F. Design test reports:
1. Indicate fastener types and spacings; and provide fastener pullout values.

2. Submit copy of manufacturer's minimum design load calculations according to ASCE 7.
 3. Submit test results meeting or exceeding values specified in the Performance Criteria Article of this specification and stamped by an independent Testing Agency.
- G. Certificates:
1. Manufacturer's Certificate that all products conform to specified requirements.
 2. Manufacturer's Representative Certificate that installation conforms to specified requirements.
- H. Quality-control reports.
1. Field quality-control reports.
- I. Warranties: Sample of special warranties.

1.06 SCHEDULING AND SEQUENCING

- A. Include in construction schedule:
1. When field measurement for factory production will be taken.
 2. Order and delivery time.
 3. Installation period.
- B. Determine that work of other trades will not hamper or conflict with necessary fabrication and storage requirements for preformed metal roofing system.
- C. Schedule field measurements far enough in advance, to permit fabrication of panels to required lengths without delay to the construction schedule.
- D. Sequence installation to avoid other activities over metal roofing.
- E. Do not cover underside of metal roofed areas until water intrusion test has been performed.

1.07 QUALITY ASSURANCE

- A. Manufacturer Qualifications: Company specializing in manufacturing products specified in this section, with not less than five years of documented experience.
- B. Installer Qualifications: Company specializing in the type of work specified, with not less than five (5) years of documented experience; trained and authorized by roofing system manufacturer with written certification from manufacturer.
1. Maintain a full-time supervisor/foreman with minimum of five (5) years experience with the installation of system similar to that specified on the job-site at all times during installation of new roof system.
 2. Upon Owner request, fabricator/installer shall submit work experience and evidence of adequate financial responsibility. The owner's representative reserves the right to inspect fabrication facilities in determining qualifications.
- C. Delegated Design: Design metal roof assembly components and anchorages under direct supervision of a Professional Structural Engineer experienced in design of this Work and licensed at California.
- D. Professional Engineer Qualifications: A professional engineer who is legally qualified to practice in jurisdiction where Project is located and who is experienced in providing engineering services of the kind indicated. Engineering services are defined as those performed for installations of assemblies that are similar to those indicated for this Project in material, design, and extent.
- E. Engineering Responsibility: Prepare design for metal roof systems, including Shop Drawings, based on testing and engineering analysis of manufacturer's standard units in systems similar to those indicated for this Project.

- F. Manufacturer's Testing Agency Qualifications: Qualified according to ASTM E 699 for testing indicated.
- G. Product Options: Information on Drawings and in Specifications establishes requirements for systems' aesthetic effects and performance characteristics. Aesthetic effects are indicated by dimensions, arrangements, alignment, and profiles of components and assemblies as they relate to sightlines, to one another, and to adjoining construction. Performance characteristics are indicated by criteria subject to verification by one or more methods including preconstruction testing, field testing, and in-service performance.
 - 1. Do not revise intended aesthetic effects, as judged solely by Architect, except with Architect's approval. If revisions are proposed, submit comprehensive explanatory data to Architect for review.

1.08 DELIVERY, STORAGE, AND HANDLING

- A. Provide strippable plastic protection on prefinished roofing panels for removal after installation.
- B. Store roofing panels on project site as recommended by manufacturer to prevent damage to panels prior to installation.
- C. Order materials based on field measurements, not on construction drawings.
- D. Deliver, store, protect and handle products to site under provisions of Section 01 6000 - Product Requirements.
- E. Coordinate delivery schedule with installation schedule. Do not deliver materials of this section to project site until suitable facilities for storage and protection are available.
- F. Protect materials from damage during transit and at project site. Store under cover, off ground, sloped to provide positive drainage, protected from wind, foreign material contamination, mechanical damage, cement, lime or other corrosive substances. Do not expose materials with strippable protective film to direct sunlight or extreme heat.
 - 1. Store preformed and prefinished material to prevent twisting, bending, or abrasion, and to provide ventilation. Slope metal sheets to ensure drainage.
 - 2. Provide protective interleaving between contact areas of exposed surfaces to prevent abrasion during shipment, storage, and handling.
 - 3. Prevent contact with materials which may cause discoloration or staining
- G. Inspect materials upon delivery. Reject and remove physically damaged or marred material from project site.
- H. Do not allow storage of other materials or allow staging of other work on installed metal panel roof system.
 - 1. Do not overload roof with stored materials.
 - 2. Do not support roof mounted equipment directly on roofing system.

1.09 WARRANTY

- A. Finish Warranty: Provide manufacturer's special warranty covering failure of factory-applied exterior finish on metal roof panels and agreeing to repair or replace panels that show evidence of finish degradation, including significant fading, chalking, cracking, or peeling within specified warranty period of five years from Date of Substantial Completion.
- B. Waterproofing Warranty: Provide manufacturer's warranty for weathertightness of roofing system, including agreement to repair or replace roofing that fails to keep out water within specified warranty period of five years from Date of Substantial Completion.

PART 2 PRODUCTS

2.01 DESIGN REQUIREMENTS

- A. Roof Panel System: Provide roof system with performance as specified when installed, designed in accordance with applicable codes.
 - 1. Make weathertight.
 - 2. Make free from objectionable warp, wave and buckle.
- B. Provide structural performance appropriate to substrate over which roof system is installed.
- C. Design and size components to withstand loads caused by wind pressures as specified in applicable code.
- D. Capacities for gauge, span or loading other than those tested may be determined by interpolation of test results within the range of test data. Extrapolation for conditions outside test range are not acceptable.
- E. Drainage: Provide positive drainage to exterior for moisture entering building enclosure or condensation occurring within exterior building envelope.

2.02 MANUFACTURERS

- A. Basis of Design: The Garland Company, R-Mer Span.
- B. Obtain all components of roof system from a single manufacturer including roll good materials if required to comply with metal roof manufacturer warranty. Secondary products required which cannot be supplied by the specified metal roof manufacturer must be those recommended and approved in writing by the specified metal roof manufacturer.
- C. Acceptable manufacturers and products are:
 - 1. Centria, SRS 3, www.centria.com.
 - 2. The Garland Company, Inc.: www.garlandco.com.
 - 3. McElroy Metal, 238T: www.mcelroymetal.com.
- D. Substitutions: See Section 01 6000 - Product Requirements.
 - 1. Requests for substitution of proposed alternate systems must meet or exceed all performance requirements listed in Performance Criteria, Warranty and Quality Assurance Articles.
 - 2. Submit complete product and test data for each proposed substitution.

2.03 ARCHITECTURAL METAL ROOF PANELS

- A. Architectural Metal Roofing: Provide complete engineered system complying with specified requirements and capable of remaining weathertight while withstanding anticipated movement of substrate and thermally induced movement of roofing system.
- B. Performance Criteria:
 - 1. Wind Uplift: Class 90 wind uplift resistance of UL 580.
 - 2. Air Infiltration: Maximum 0.06 cfm/sq ft at air pressure differential of 6.24 lbf/sq ft, when tested according to ASTM E1680.
 - 3. Water Penetration: No water penetration when tested according to procedures and recommended test pressures of ASTM E1646. Perform test immediately following air infiltration test.
 - 4. Thermal Movement: Design system to accommodate without deformation, leaks, or stress to supporting structure anticipated thermal movement over ambient temperature range of 120 degrees F.
 - a. Interface between panel and clip shall provide for unlimited thermal-induced movement in each direction along the longitudinal direction of the roof panel.

- b. Locate panel fixed connection at roof ridge unless otherwise required by project conditions and approved by specified manufacturer's designer.
- C. Metal Panels: Factory-formed panels with factory-applied finish.
 - 1. Steel Panels:
 - a. Aluminum-zinc alloy-coated steel conforming to ASTM A792/A792M; minimum AZ50 coating.
 - b. Steel Thickness: Minimum 24 gage (0.024 inch).
 - 2. Profile: Standing seam, with minimum 2-3/8 inch minimum seam height; concealed fastener system for field seaming with special tool.
 - a. Symmetrical profile permitting removal of individual panels without removing adjacent panels.
 - 3. Texture: Smooth.
 - 4. Length: Full length of roof slope, without lapped horizontal joints.
 - 5. Width: Maximum panel coverage of 24 inches.

2.04 ATTACHMENT SYSTEM

- A. Concealed System: Provide manufacturer's standard stainless steel or nylon-coated aluminum concealed anchor clips designed for specific roofing system and engineered to meet performance requirements, including anticipated thermal movement.
 - 1. Concealed Anchor Clips: G-90 galvanized steel, 16 gauge, 40,000 psi yield ONE (1) piece clip with projecting legs.
 - a. Clip design: Isolate sealant in panel cap from contact with clip to limit sealant damage during expansion and contraction.
 - b. Configured to maintain minimum clearance of 3/8 inch between panel and substrate for ventilation to reduce condensation and reduce contact of panel fastener head to panel.
 - 2. Snap-on Seam cap: Minimum 1 inch wide "T" shaped of continuous length matching roof panel, field seamed by manufacturer's seaming machine.
 - a. Cap designed to receive continuous double bead of sealant and avoid contact with anchor clip, allowing unlimited thermal movement of panel without damage to cap sealant.
- B. Fasteners: As recommended by manufacturer for project conditions and panel type, concealed wherever possible.
 - 1. Concealed fasteners: Corrosion resistant steel screws designed to meet structural loading requirements. The normal minimum screw size shall be Rawl #14.
 - 2. Exposed fasteners: Corrosion resistant steel screws (cadmium or zinc coatings are not acceptable), stainless steel with neoprene sealing washer, or 3/16 inch diameter waterproof rivets with color matched finish.

2.05 FABRICATION

- A. Form metal work true to required shape, accurate in size and radius, square and free from distortion or defects, with clear, sharp, straight, and uniform bends and rises. Hem exposed edges of flashings. Fabricate to predetermined exact lengths wherever possible. Cut panels to precise lengths indicated from field measurements.
- B. Machine roll roof and flashing elements required to be curved or radiused. Do not field bend or "walk-down". Provide true curves, segmented fabrication not allowed.
- C. Panels: Provide factory or field fabricated panels with applied finish and accessory items, using manufacturer's standard processes as required to achieve specified appearance and performance requirements.

- D. Joints: Provide captive gaskets, sealants, or separator strips at panel joints to ensure weathertight seals, eliminate metal-to-metal contact, and minimize noise from panel movements.
- E. Accessories: Factory-fabricate trim and flashing components in longest practical lengths.
 - 1. Provide mitered corners, joined using closed end pop rivets and joint sealant.
- F. Roof-related Flashings: Provide as specified in related sections, as required by roofing material manufacturers and referenced standards. Coordinate work of this section with related sections. Provide complete systems without conflict or omission.
 - 1. Fabricate roofing and related sheet metal work in accord with approved shop drawings and applicable standards.

2.06 FINISHES

- A. Energy Performance: Provide roofing system with initial Solar Reflectance not less than 0.70 when tested according to ASTM D 1549 and Thermal Emittance not less than 0.75 when tested according to ASTM D 1371 and listed on Cool Roof Rating Council's CRRC-1.
 - 1. Energy Performance: ENERGY STAR and Cool Roof Rating Council (CRRC) rated.
- B. Fluoropolymer Coating System: Manufacturer's standard multi-coat thermocured coating system, including minimum 70 percent fluoropolymer color topcoat with minimum total dry film thickness of 0.9 mil; color and gloss to match sample.
- C. Concealed Surface Finish: Baked-on polyester coating with 0.20-0.30 mil DFT.
- D. Color selected by Architect from the Manufacturer's standard color range.

2.07 ACCESSORIES

- A. Miscellaneous Sheet Metal Items: Provide flashings, gutters, downspouts, trim, moldings, closure strips, preformed crickets, caps, and equipment curbs of the same material, thickness, and finish as used for the roofing panels. Items completely concealed after installation may optionally be made of stainless steel.
- B. Rib and Ridge Closures: Provide prefabricated, close-fitting components of steel with corrosion resistant finish or combination steel and closed-cell foam.
- C. Sealants: Types specified in related section with the following characteristics, except concealed seam sealant.
 - 1. Exposed Sealant: Elastomeric; silicone, polyurethane, or silyl-terminated polyether/polyurethane.
 - 2. Concealed sealant must be non-hardening, butyl type.
 - 3. Seam Sealant: Non-skinning, non-drying type recommended and factory-applied by roof panel manufacturer.
 - 4. Exposed sealant colors as selected by Architect, compatible with roof finish color.
- D. Underlayment: Self-adhering rubber-modified asphalt sheet complying with ASTM D1970/D1970M; 30 mil total thickness; with strippable release film and woven polypropylene sheet top surface.
 - 1. Sheet Thickness: 22 mil (0.022 inch) minimum total thickness.
 - 2. Self Sealability: Passing nail sealability test specified in ASTM D1970/D1970M.
 - 3. Low Temperature Flexibility: Passing test specified in ASTM D1970/D1970M.
 - 4. High Temperature Resistance formulation.
 - 5. Water Vapor Permeance: 0.05 perm, maximum, when tested in accordance with ASTM E96/E96M Procedure A (desiccant method).
 - 6. Products:
 - a. Grace Construction Products; Ultra: www.graceconstruction.com.
 - b. Henry Company; Blueskin PE200HT: www.henry.com/#sle.

c. Substitutions: See Section 01 6000 - Product Requirements.

E. Provide all miscellaneous accessories for complete installation.

2.08 FABRICATION

- A. Form metal work true to required shape, accurate in size and radius, square and free from distortion or defects, with clear, sharp, straight, and uniform bends and rises. Hem exposed edges of flashings. Fabricate to predetermined exact lengths wherever possible. Cut panels to precise lengths indicated from field measurements.
- B. Machine roll roof and flashing elements required to be curved or radiused. Do not field bend or "walk-down". Provide true curves, segmented fabrication not allowed.
- C. Panels: Fabricate panels and accessory items at factory to the greatest extent possible, using manufacturer's standard processes as required to achieve specified appearance and performance requirements.
- D. Joints: Factory-install captive gaskets, sealants, or separator strips at panel joints to provide weathertight seals, eliminate metal-to-metal contact, and minimize noise from panel movements.
- E. Accessories: Factory-fabricate trim and flashing components in longest practical lengths.
 - 1. Provide mitered corners, joined using closed end pop rivets and joint sealant.
- F. Roof-related Flashings: Provide as specified in related sections, as required by roofing material manufacturers and referenced standards. Coordinate work of this section with related sections. Provide complete systems without conflict or omission.
 - 1. Fabricate roofing and related sheet metal work in accord with approved shop drawings and applicable standards.

PART 3 EXECUTION

3.01 EXAMINATION

- A. Do not begin installation of preformed metal roof panels until substrates have been properly prepared.
 - 1. Determine if work of other trades which penetrates the roof or is to be made watertight by the roof is in place and approved prior to installation of roofing.
 - 2. Verify pipes, sleeves, or vents through roof are solidly set, reglets are in place, and nailing strips located.
 - a. Locate penetrations in the center of roofing panel.
 - 3. Verify roofing termination, base flashings and gutter flanges are in place, sealed, and secure.
 - 4. Notify Architect in writing if substrates are not suitable for application of panel system.
 - 5. Do not proceed with installation until substrates are acceptable.
- B. Structural surfaces: Smooth, even, sound, surface dry 19 percent maximum, clean and free of depressions, waves, or projections before material is applied.
 - 1. Examine the alignment and placement of the building structure and substrate. Correct any objectionable warp, waves or buckles in the substrate before proceeding with installation of the preformed metal roofing. The installed roof panels will follow the contour of the structure and may appear irregular if not corrected.
- C. Apply no materials during wet weather or on wet surface.

3.02 INTERFACE WITH OTHER WORK

- A. Coordinate with roof accessories, miscellaneous sheet metal accessories, piping vents and other items specified in related sections penetrating metal roofing work. Avoid conflict or omission in waterproofing systems and provide watertight installation.

3.03 PREPARATION

- A. Verify field dimensions prior to ordering materials.
 - 1. Establish straight side and crosswise benchmarks.
 - 2. Check rectangular roofs for squareness and straightness. Gable ends may not be straight; set a true line for the gable clips and flashing with stringline.
 - 3. Measure the roof lengthwise to confirm panel lengths, overhangs, coverage of flashings at eaves and ridges and verify clearances for thermal movement.
- B. Broom clean wood sheathing prior to installation of roofing system.
- C. Coordinate roofing work with provisions for roof drainage, flashing, trim, penetrations, and other adjoining work to assure that the completed roof will be free of leaks.
- D. Coordinate installation of waterproof membrane over roof sheathing with 06 1000.
- E. Remove protective film from surface of roof panels immediately prior to installation. Strip film carefully, to avoid damage to prefinished surfaces.
- F. Separate dissimilar metals by applying a bituminous coating, self-adhering rubberized asphalt sheet, or other permanent method approved by roof panel manufacturer.
- G. Where metal will be in contact with wood or other absorbent material subject to wetting, seal joints with sealing compound and apply one coat of heavy-bodied bituminous paint.

3.04 INSTALLATION

- A. Overall: Install roofing system in accordance with approved shop drawings and panel manufacturer's instructions and recommendations, as applicable to specific project conditions. Anchor all components of roofing system securely in place while allowing for thermal and structural movement.
 - 1. Install roofing system with concealed clips and fasteners, except as otherwise recommended by manufacturer for specific circumstances. Where exposed fasteners are unavoidable, use fasteners prefinished to match panels.
 - 2. Minimize field cutting of panels. Where field cutting is absolutely required, use methods that will not distort panel profiles. Use of torches for field cutting is absolutely prohibited.
- B. Accessories: Install all components required for a complete roofing assembly, including flashings, gutters, downspouts, trim, moldings, closure strips, preformed crickets, caps, equipment curbs, rib closures, ridge closures, and similar roof accessory items.
 - 1. Install surface mounted reglets true to lines and levels. Seal top of reglets with sealant.
- C. Flashings: Coordinate to provide weathertight conditions at roof terminations. Fabricate and install in accordance with standards of SMACNA Manual.
 - 1. Install flashings as shown on Drawings and approved shop drawings.
 - 2. Secure flashings in place using concealed fasteners.
 - 3. Cleat and seam all joints.
 - 4. Apply plastic cement compound between metal flashings and felt flashings.
 - 5. Fit flashings tight in place. Make corners square, surfaces true and straight in planes, and lines accurate to profiles and radius indicated or required.
 - 6. Seal metal joints watertight with two parallel beads of sealant, do not permit sealant to migrate to exposed surfaces.

7. Overlap roof panels at least 6 inches.
 8. Install flashings to allow thermal movement.
- D. Install self-adhering underlayment on roof deck before installing preformed metal roof panels. Secure by methods acceptable to roof panel manufacturer, minimizing use of metal fasteners. Apply from eaves to ridge in shingle fashion, overlapping horizontal joints a minimum of 4 inches and side and end laps a minimum of 6 inches. Offset seams in successive layers of underlayment.
1. Cover entire surface under panels; holes or tears not permitted.
 2. Lap sheet metal flashings. All laps shall weather to exterior.
 3. Double layer at changes in plane by extending 6 inches around corner from each side.
 4. Install a 3'-0" wide additional layer of self-adhering underlayment at flashing and panel terminations (ridges, eaves, rakes, and roof penetrations).
- E. Roof Panels: Install panels in strict accordance with manufacturer's instructions, minimizing transverse joints except at junction with penetrations. Install panels plumb, level, and true to line.
1. Form weathertight standing seams incorporating concealed clips, using an automatic mechanical seaming device approved by the panel manufacturer.
 2. Fully interlock panels with adjacent panels; apply sealants as recommended by panel manufacturer to achieve weathertight installation.
 3. Provide sealant tape or other approved continuous joint sealer at lapped panel joints.
 4. Install sealant or sealant tape, as recommended by panel manufacturer, at end laps and side joints.
 5. Cut panels only at approved locations, and only where necessary to make openings for penetrations and field adjustments. Cut using a power saw with metal cutting blade.
 - a. Back paint concealed metal surfaces with protective backing paint to a minimum dry film thickness of 0.45 mil.
 6. Isolate dissimilar metals and masonry or concrete from metals with bituminous coating. Provide gasketed stainless steel fasteners between dissimilar metals.
 7. Provide for temperature expansion/contraction movement of panels at roof penetrations and roof mounted equipment in accordance with panel manufacturer's product data and design calculations.
- F. Anchorage shall allow for temperature expansion/contraction movement without stress or elongation of panels, clips, or anchors. Attach clips to structural substrate using fasteners of size, length and spacing as determined by manufacturer's design analysis to resist imposed loads.
1. Provide fastener head size beneath roof panel as recommended by panel manufacturer.
 2. Limit exposed fasteners to extent indicated on shop drawings.
- G. Do not allow shavings, metal dust, or chips to fall on panels.
1. Capture all drilling debris with a rag or cloth placed on the panels at the drilling operation.
- H. Provide installed roof that is true to line and plane, free of dents, and physical defects with a minimum of oil canning.

3.05 CONSTRUCTION TOLERANCES

- A. Maximum Alignment Variation: 1/4 inch in 20 feet, 3/8" in 40'-0" or more.

3.06 FIELD QUALITY CONTROL

- A. Testing:
1. Re-test until roof is shown to be watertight.
- B. Manufacturer Field Services: Provide daily site inspection for a minimum of one (1) hour during active roofing operations by an experienced, full time employee of the roofing manufacturer. Submit written reports as specified.

3.07 CLEANING

- A. Clean exposed sheet metal work at completion of installation. Remove grease and oil films, excess joint sealer, handling marks, and debris from installation, leaving the work clean and unmarked, free from dents, creases, waves, scratch marks, or other damage to the finish.
- B. Touch up minor abrasions and exposed fasteners with matching paint provided by panel manufacturer. Remove and replace panels that cannot be satisfactorily touched up.
 - 1. No exposed sealant or visible raw metal.
- C. Sweep and remove chips, shavings, and dust from roof on a daily basis during installation period. Leave installed work clean, free from grease, finger marks and stains.
- D. Upon completion of installation, remove scraps and debris from project site.

3.08 PROTECTION

- A. Do not permit storage of materials or roof traffic on installed roof panels. Provide temporary walkways or planks as necessary to avoid damage to completed work. Protect roofing until completion of project.
- B. Touch-up, repair, or replace damaged roof panels or accessories before Date of Substantial Completion.

END OF SECTION

SECTION 07 5200

MODIFIED BITUMINOUS MEMBRANE ROOFING

PART 1 GENERAL

1.01 SECTION INCLUDES

- A. Modified bituminous roofing membrane, conventional application with hot asphalt.
- B. Deck sheathing.
- C. Base flashings.
- D. Roofing cant strips, accessories, and walkway pads.

1.02 RELATED REQUIREMENTS

- A. Pertinent Sections specifying Volatile Organic Compound (VOC) Content Restrictions.
- B. Work of other sections which relates to or penetrates the roof.
- C. Section 01 8113 -Sustainable Design Requirements.
- D. Section 07 2129 Sprayed Insulation
- E. Section 07 4113 - Preformed Metal Roofing.
- F. Section 07 6200 - Sheet Metal Flashing and Trim: Counterflashings, reglets.
- G. Section 07 7100 - Roof Specialties: Prefabricated roofing expansion joint flashing.
- H. Section 08 6200 - Unit Skylights: Skylight frame, integral curb, and counterflashing.

1.03 REFERENCE STANDARDS

- A. ASTM C728 - Standard Specification for Perlite Thermal Insulation Board.
- B. ASTM D41/D41M - Standard Specification for Asphalt Primer Used in Roofing, Dampproofing, and Waterproofing.
- C. ASTM D312/D312M - Standard Specification for Asphalt Used in Roofing.
- D. ASTM D4586/D4586M - Standard Specification for Asphalt Roof Cement, Asbestos-Free.
- E. ASTM D6162/D6162M - Standard Specification for Styrene Butadiene Styrene (SBS) Modified Bituminous Sheet Materials Using a Combination of Polyester and Glass Fiber Reinforcements.
- F. ASTM D6163/D6163M - Standard Specification for Styrene Butadiene Styrene (SBS) Modified Bituminous Sheet Materials Using Glass Fiber Reinforcements.
- G. ASTM D6164/D6164M - Standard Specification for Styrene Butadiene Styrene (SBS) Modified Bituminous Sheet Materials Using Polyester Reinforcements.
- H. ASTM E108 - Standard Test Methods for Fire Tests of Roof Coverings.
- I. California Code of Regulations, Title 24, Part 2, California Building Code (CBC), International Building Code.
- J. California Code of Regulations, Title 24, Part 11 California Green Building Standards Code, "CAL-Green".
- K. FM DS 1-28 - Wind Design.

- L. NRCA (RM) - The NRCA Roofing Manual.
- M. SPRI RP-4 - Wind Design Standard for Ballasted Single-Ply Roofing Systems.
- N. UL (FRD) - Fire Resistance Directory.

1.04 ADMINISTRATIVE REQUIREMENTS

- A. Coordinate with installation of associated flashings and counterflashings installed by other sections.
- B. Preinstallation Meeting:
 - 1. Convene two weeks before starting work of this section. Meet at Project site with Installer, installer of each component of associated work, installers of deck or substrate construction to receive roofing work, installers of rooftop units and other work in the around roofing that must precede or follow roofing work (including mechanical work if any), Architect/Owner, roofing system manufacturer's representative, and other representatives directly concerned with performance of the Work, including (where applicable) Owner's insurers, test agencies, and governing authorities. Objectives to include:
 - 2. Review preparation and installation procedures and coordinating and scheduling required with related work.
 - a. Review methods and procedures related to roofing work.
 - b. Review structural loading limitations of new deck.
 - c. Review roofing systems requirements (drawings, specifications, and other contract documents).
 - d. Review required submittals, both completed and yet to be completed.
 - e. Review and finalize construction schedule related to roofing work and verify availability of materials, Installer's personnel, equipment, and facilities needed to make progress and avoid delays.
 - f. Review required inspection, testing, certifying, and material usage accounting procedures.
 - g. Review weather and forecasted weather conditions and procedures for coping with unfavorable conditions, including provision of temporary roofing over occupied spaces.
 - h. Record discussion of conference, including decisions and agreements (or disagreements) reached, and furnish copy of record to each party attending. If substantial disagreements exist at conclusion of conference, determine how disagreements will be resolved and set date for reconvening conference.
 - i. Review notification procedures for weather or non-working days.
- C. Sequence installation of roofing with related units of work specified in other sections to ensure that roof assemblies, including roof accessories, flashing, trim, and joint sealers, are protected against damage from effects of weather, corrosion, and adjacent construction activity.

1.05 SUBMITTALS

- A. See Section 01 3300 - Submittals, for submittal procedures.
- B. Product Data: Provide manufacturer's catalog data for membrane and bitumen materials, base flashing materials, vapor retarder, and surfacing.
- C. CAL-GREEN Submittals:
 - 1. Product Data – VOC Limits: For adhesives sealants, fillers, primers and coatings, documentation including printed statement of VOC contents, comply with limits specified in related section.
 - 2. Product Test Reports: For roof materials, indicating that roof materials comply with Solar Reflectance Index requirement and demonstrate Cool Roof Rating Council (CRRC) listing.

- D. Shop Drawings: Indicate joint or termination detail conditions, conditions of interface with other materials, setting plan for tapered insulation, mechanical fastener layout, and crickets, saddles and tapered edge strips, including slopes.
- E. Samples for Verification:
 - 1. Cap sheet, of color required.
 - 2. Flashing sheet, of color required.
 - 3. Base and intermediate plies.
 - 4. Walkway pads or rolls, of color required.
- F. Manufacturer's Qualification Statement.
- G. Manufacturer's Qualification Statement.
- H. Installer's Qualification Statement.
- I. Installer's Qualification Statement.
- J. Manufacturer's Installation Instructions: Indicate special procedures.
- K. Product Test Reports: For components of membrane roofing system, for tests performed by manufacturer and witnessed by a qualified testing agency.
- L. Manufacturer's Certificate: Certify that products meet or exceed specified requirements.
 - 1. Manufacturer's ISO 9001 compliance.
 - 2. UL 580 1-90 Wind Uplift.
 - 3. External Fire Test: ASTM E108, Class A.
- M. Manufacturer's Field Reports: Indicate procedures followed, ambient temperatures, humidity, wind velocity during application, supplementary instructions given, and means of resolving discrepancies and non-conforming work.
- N. Warranty: Submit manufacturer warranty and ensure forms have been completed in Owner's name and registered with manufacturer.

1.06 DELIVERY, STORAGE, AND HANDLING

- A. Deliver products in manufacturer's original containers, dry, undamaged, with seals and labels intact.
- B. Store products in weather protected environment, clear of ground and moisture; ballast materials may be stored outdoors.
- C. Do not leave unused rolled goods on the roof overnight or when roofing work is not in progress unless protected from weather and other moisture sources.
- D. Handle and store materials or equipment in a manner to avoid significant or permanent deflection of deck.

1.07 FIELD CONDITIONS

- A. Do not apply roofing membrane when environmental conditions are outside the ranges recommended by manufacturer.
- B. Respond immediately to correction of roof leakage during construction.
- C. Do not apply roofing membrane during unsuitable weather.
- D. Do not apply roofing membrane to damp or frozen deck surface or when 40% chance of precipitation is expected or occurring.

- E. Proceed with roofing work only when existing and forecasted weather conditions will permit unit of work to be installed in accordance with manufacturer's recommendations and warranty requirements.
- F. Do not expose materials vulnerable to water or sun damage in quantities greater than can be weatherproofed the same day.

1.08 WARRANTY

- A. Special Warranty: Manufacturer's No Dollar Limit Warranty, Manufacturer agrees to repair or replace components of roofing system that fail in materials or workmanship within specified warranty period.
 - 1. Special warranty includes membrane roofing, base flashing, roof insulation, fasteners, cover boards, substrate boards, vapor retarders (where included) , and walkway product.
 - 2. Warranty Period: 30 years from date of Substantial Completion.
- B. Special Project Warranty: Submit roofing Installer's warranty, on warranty form at end of this Section, signed by Installer, covering the Work of this Section, including all components of roofing system such as membrane roofing, base flashing, roof insulation, fasteners, cover boards, substrate boards, vapor retarders (where included) , and walkway products, for the following warranty period:
 - 1. Correct defective Work within a two year period after Date of Substantial Completion.

PART 2 PRODUCTS

2.01 PERFORMANCE REQUIREMENTS

- A. VOC Limits for adhesives, sealants, fillers, primers and coatings . Comply with limits specified in related section.

2.02 MANUFACTURERS

- A. Source Limitations: Obtain components including base sheets, flashings, asphalt, roof insulation and fasteners for roofing system from same manufacturer as membrane roofing or manufacturer approve by membrane roofing manufacturer in writing and included in their warranty.
- B. Membrane Materials:
 - 1. Garland Co., Inc. is Basis of Design: www.garlandco.com.
 - 2. Firestone Building Products Company: www.firestonebpco.com/#sle.
 - 3. Johns Manville: www.jm.com.
- C. Insulation:
 - 1. Same as membrane manufacturer, or provide membrane manufacturer's written approval and warranty inclusion.
- D. Accessory Materials:
 - 1. Same as membrane manufacturer, or provide membrane manufacturer's written approval and warranty inclusion.

2.03 ROOFING - CONVENTIONAL APPLICATION

- A. Modified Bituminous Roofing: Two base plies and cap sheet.
 - 1. Two plies of SBS modified bitumen base sheets of Type and Grade recommended by manufacturer for application indicated, bonded to the insulation assembly with hot asphalt.
 - 2. ASTM D-312 Type III or IV steep asphalt, as required by manufacturer for roof slopes required.
 - 3. Flashings: Same material as membrane, smooth faced.
 - 4. Cap Sheet: Mineral surfaced rubber modified roofing membrane of Type and Grade specified, bonded to the base plies with hot asphalt.
 - 5. Acrylic Coating.
- B. Roofing Assembly Requirements:

1. Energy Performance: Provide roofing system with initial Solar Reflectance not less than 0.70 based on three-year aged data when tested according to ASTM D 1549 and Thermal Emittance not less than 0.75 when tested according to ASTM D 1371 and listed on Cool Roof Rating Council's CRRC-1.
 - a. Energy Performance: ENERGY STAR and Cool Roof Rating Council (CRRC) rated.
 2. External Fire Exposure Classification: ASTM E108 Class A, UL (FRD) listed.
 3. Wind Resistance Classification: Factory Mutual 1-75, in accordance with FM DS 1-28.
 4. Surfacing: Mineral granules.
- C. Insulation: See Section 07 2129 - Sprayed Insulation.

2.04 MEMBRANE AND SHEET MATERIALS

- A. General: Provide Cap Sheet, Base and Intermediate plies from listed manufacturers with minimum quality described by ASTM D6162, ASTM D6163, or ASTM D6164 for types and styles described below. Provide all plies in an assembly fabricated to the same standard.
- B. Cap Sheet Membrane: Polymer modified asphalt, reinforced with non-woven fabric; granule surfaced; with the following characteristics:
 1. Minimum Quality: ASTM D6162/D6162M Type I; styrene-butadiene-styrene (SBS) modified, glass fiber and polyester reinforced.
 2. Minimum Quality: ASTM D6163/D6163M Type I; styrene-butadiene-styrene (SBS) modified, glass fiber reinforced.
 3. Minimum Quality: ASTM D6164/D6164M Type II; styrene-butadiene-styrene (SBS) modified, polyester reinforced.
- C. Base Sheet and Intermediate Ply Membrane: Polymer modified asphalt, reinforced with same non-woven fabric as the Cap Sheet Membrane; smooth surfaced; with the following characteristics:
 1. Minimum Quality: ASTM D6162 Type I; styrene-butadiene-styrene (SBS) modified, glass fiber and polyester reinforced.
 2. Minimum Quality: ASTM D6163 Type I; styrene-butadiene-styrene (SBS) modified, glass fiber reinforced.
 3. Minimum Quality: ASTM D6164/D6164M Type I; styrene-butadiene-styrene (SBS) modified, polyester reinforced.
- D. Flexible Flashing Material: Same material as membrane, Type G or L as required by manufacturer to suit assembly.

2.05 BITUMINOUS MATERIALS

- A. General: Products from same manufacturer as membrane roofing or manufacturer approved by membrane roofing manufacturer in writing and included in their warranty.
- B. Bitumen: Asphalt, ASTM D312 Type IV.
- C. Primer: ASTM D41/D41M, asphalt type.
- D. Roof Cement: ASTM D4586/D4586M, Type II, asbestos free.

2.06 DECK SHEATHING AND COVER BOARDS

- A. General: Products from same manufacturer as membrane roofing or manufacturer approved by membrane roofing manufacturer in writing and included in their warranty.
- B. Deck Sheathing: Perlite board, ASTM C728, 3/4 inch thick.

2.07 SURFACING MATERIALS - CONVENTIONAL APPLICATION

- A. Protective Coating: Acrylic, white color.
 - 1. Roofing Membrane Manufacturer's recommended acrylic coating, meeting reflectivity and emissivity performance requirements specified, manufactured or approved by membrane roofing manufacturer in writing and included in their warranty.
 - 2. Substitutions: Not permitted.
- B. Walkway Pads: Suitable for maintenance traffic, contrasting color or otherwise visually distinctive from roof membrane, manufactured or approved by membrane roofing manufacturer in writing and included in their warranty..
 - 1. Composition: Asphaltic with mineral granule surface or Roofing membrane manufacturer's standard.
 - 2. Size: 18 by 18 inch.
 - 3. Surface Color: White or yellow.
 - 4. Manufacturers:
 - a. Substitutions: See Section 01 6000 - Product Requirements.

2.08 ACCESSORIES

- A. Cant and Edge Strips: Asphalt-impregnated wood fiberboard, compatible with roofing materials; cants formed to 45 degree angle.
- B. Nails and Fasteners: Non-ferrous metal or hot-dipped galvanized steel except that hard copper nails shall be used with copper; aluminum or stainless steel nails shall be used with aluminum; and stainless steel nails shall be used with stainless steel. Nails and fasteners shall be flush-driven through flat metal discs of not less than 1-inch diameter. Metal discs may be omitted when one piece composite nails or fasteners with heads not less than 1-inch diameter are used.
- C. Vandal-proof Vent Cap: Dura-coated cast iron body and hooded dome cap, secured by vandal-resistant set screw fasteners.
 - 1. Santa Rosa Lead Products, Healdsburg CA.
 - 2. Substitutions: See Section 01 6000 - Product Requirements.
- D. Sealants: As recommended by membrane manufacturer.

PART 3 EXECUTION

3.01 EXAMINATION

- A. Verify that surfaces and site conditions are ready to receive work.
 - 1. Do not proceed with roofing until unsatisfactory conditions have been corrected in a manner acceptable to Installer.
- B. Verify deck is supported and secure.
- C. Verify deck is clean and smooth, flat, free of depressions, waves, or projections, properly sloped and suitable for installation of roof system.
- D. Verify deck surfaces are dry and free of snow or ice.
- E. Verify that roof openings, curbs, and penetrations through roof are solidly set, and cant strips are in place.

3.02 GENERAL INSTALLATION REQUIREMENTS

- A. Cooperate with manufacturer, inspection and test agencies engaged or required to perform services in connection with roofing installation.

- B. Protect other work from spillage of modified bitumen roofing materials, and prevent liquid materials from entering or clogging drains and conductors. Replace or restore other work damaged by installation of modified bituminous roofing system work.
- C. Coordinate installing roofing system components so that insulation and roofing plies are not exposed to precipitation or left exposed overnight.
- D. Asphalt Bitumen Heating: Heat and apply bitumen according to EVT Method as recommended by NRCA.
 - 1. Do not raise temperature above minimum normal fluid-holding temperature necessary to attain EVT (plus 5 degrees F at point of application) more than 1 hour prior to time of application.
 - 2. Determine flash point, finished blowing temperature, EVT, and fire-safe handling temperature of bitumen either by information from manufacturer or by suitable test.
 - 3. Do not exceed recommended temperature limits during bitumen heating.
 - 4. Do not heat to a temperature higher than 25 degrees F below flash point.
 - 5. Discard bitumen that has been held at temperature exceeding finishing blowing temperature (FBT) for more than 3 hours.
 - 6. Keep kettle lid closed except when adding bitumen.
- E. Bitumen; Mopping Weights: For interply mopping, apply bitumen at the rate of approximately 25 lb of asphalt per roof square (plus or minus 25 percent on a total job average basis).
- F. Substrate joint Penetrations: Prevent bitumen from penetrating substrate joints, entering building, or damaging roofing system components or adjacent building construction.
- G. Apply roofing materials as specified herein unless recommended otherwise by manufacturer's instructions.
- H. Keep roofing materials dry before and during application.
- I. Do not permit phased construction. Complete application of roofing plies, modified sheet and flashing in a continuous operation.
 - 1. Begin and apply only as much roofing in one day as can be completed that same day.
- J. Coordinate with roof accessories, miscellaneous sheet metal accessory items, including piping vents and other devices to be coordinated with the roofing work as specified in other sections to avoid conflict or omission in waterproofing systems and to provide watertight installation.

3.03 WOOD DECK PREPARATION

- A. Verify flatness and tightness of joints of wood decking. Fill knot holes with latex filler.
- B. Confirm dry deck by moisture meter with 12 percent moisture maximum.
- C. All roof deck overlaid with perlite board. No roofing installed over exposed wood deck or insulation.
 - 1. Place boards in a method to maximize contact bedding. Notch out undersides of boards which directly cover structural fasteners or strapping which are attached to the roof deck. Make notch equal to the length, width and depth of structural strap or fastener. Install boards to prevent "bubbles", high spots or dams across direction of required drainage flow.

3.04 MEMBRANE APPLICATION

- A. Equiviscous Temperature (EVT) at Point of Application: In accordance with NRCA recommendations.
- B. Apply modified bituminous membrane roofing system in accordance with manufacturer's recommendations and NRCA (RM) applicable requirements.

- C. Apply membrane; lap and seal edges and ends permanently waterproof.
- D. Lap membrane ends eight inches minimum. Stagger end laps twelve inches minimum.
- E. Extend membrane plies two inches beyond top edges of cants at walls and projections.
- F. Membrane Plies: Install (2) two ply sheets in hot bitumen at recommended rate, shingled uniformly to achieve two ply coverage over the prepared substrate. Shingle in proper direction to shed water to drain on each area of roof.
- G. Apply smooth, free from air pockets, wrinkles, fish-mouths, or tears. Ensure full bond of membrane to substrate.
- H. Protected Membrane Application: Extend membrane over vapor and air barrier of wall construction and seal.
- I. At end of day's operation, install waterproof cut-off. Remove cut-off before resuming roofing.
- J. At intersections with vertical surfaces:
 - 1. Extend membrane and base sheet over cant strips and up a minimum of 8 inches onto vertical surfaces.
 - 2. Mop on base flashing of two additional plies of base flashing material.
 - 3. Apply flexible flashing over membrane.
 - 4. Secure flashing to nailing strips at 4 inches on center.
 - 5. Insert base flashing into reglets and secure.
- K. Around roof penetrations, mop in and seal flanges and flashings with flexible flashing.
- L. Coordinate installation of roof drains and sumps and related flashings.

3.05 MODIFIED MEMBRANE CAP SHEET APPLICATION

- A. Bond modified membrane cap sheet securely to base layers with asphalt at the rate recommended by the membrane manufacturer.
- B. The cap sheet membrane roll must push a puddle of asphalt in front of it with asphalt slightly visible at all side laps. Eliminate air entrapment under the membrane.
- C. Apply firm roller pressure to all seams, achieve secure bond of laps to substrate.
- D. Place subsequent rolls of modified membrane cap sheet across roof as described above with a minimum of 4 inch side laps and 8 inch end laps and greater where required by manufacturer. Stagger end laps. Lay modified membrane in same direction as the underlayers, do not permit cap sheet laps to coincide with base layer laps.
- E. Apply asphalt no more than five feet ahead of each roll being embedded.
- F. Extend membrane 2 inches minimum, and greater as required by manufacturer, beyond top edge of all cants in full moppings of asphalt.

3.06 FLASHING MEMBRANE INSTALLATION - GENERAL

- A. Seal all curb, wall and parapet flashings daily with an application of mastic and mesh. Do not permit moisture to enter behind, around, or under the roof or flashing membrane.
- B. Prepare all walls, penetrations and expansion joints to be flashed and other locations required, with asphalt primer at the rate of one gallon per 100 square feet or as otherwise required by manufacturer. Allow primer to dry tack free.

- C. Apply modified membrane cap sheet as the flashing membrane at vertical surfaces: Adhere to underlying base flashing ply with asphalt and nail at 8 inches on center.
- D. Fully adhere the entire sheet of flashing membrane to substrate with asphalt.
- E. Seal all vertical laps of flashing membrane with a three course application of roof cement and fiberglass mesh.
- F. Coordinate roofing work with work specified in other sections, including but not limited to:
 - 1. Counterflashing, cap flashings, expansion joints, and similar sheet metal elements.
 - 2. Roof accessories, skylights, miscellaneous sheet metal accessory items, including piping vents and other similar devices or elements.

3.07 FLASHING MEMBRANE INSTALLATION (SPECIFIC)

- A. Metal Edge Detail:
 - 1. Install 2x4 nominal pressure treated wood nailer at all perimeter metal edges. Butt tapered insulation up against nailer.
 - 2. Run all plies over the edge. Assure coverage of all wood nailers. Fasten plies with ring shank nails 8 inches on center.
 - 3. Install continuous cleat fasten 6 inches on center. Fasten flange to wood nailer every 6 inches staggered.
 - 4. Install new metal edge hooked to continuous cleat.
 - 5. Prime metal edge at a rate of 100 square feet per gallon and allow to dry.
 - 6. Strip in flange with base flashing ply covering entire flange with 6 inches on to the field of roof in bitumen. Ensure ply laps do not coincide with metal laps.
 - 7. Install second modified flashing ply installed over the base flashing ply, 9 inches on to the field of roof in bitumen.
- B. Roof Edge With Gutter:
 - 1. Install a 2x4 pressure treated wood nailer at all perimeter metal edges. Butt tapered insulation up against nailer.
 - 2. Run all plies over the edge. Assure coverage of all wood nailers. Fasten plies with ring shank nails 8 inches on center.
 - 3. Install gutter and strapping.
 - 4. Install new metal edge hooked to continuous cleat. Fasten flange to wood nailer every 6 inches staggered.
 - 5. Prime metal edge at a rate of 100 square feet per gallon and allow to dry.
 - 6. Strip in flange with base flashing ply covering entire flange with 6 inches onto the field of roof in bitumen. Ensure ply laps do not coincide with metal laps.
 - 7. Install second modified flashing ply installed over the base flashing ply, 9 inches on to the field of roof in bitumen.
- C. Coping Cap:
 - 1. Prime vertical wall at manufacturer's recommended rate and allow to dry.
 - 2. Set cant in bitumen. Run all field plies over cant a minimum of 2 inches.
 - 3. Attach tapered board to top of wall.
 - 4. Install base flashing ply covering entire wall and wrapped over top of wall with 6 inches on to the field of roof set in hot asphalt. Nail membrane 8 inches on center.
 - 5. Ensure membrane lap with air barrier membrane at face of exterior wall.
 - 6. Install second modified flashing ply over the base flashing ply, 9 inches on to field of roof set in bitumen. Treat vertical seams with three course application of mastic and mesh, allow to cure and coat with acrylic coating.
 - 7. Install preformed metal coping cap as specified in related section.

- D. Curb Detail/Air Handling Station:
1. Minimum curb height is 8 inches above surface of adjacent roof. Prime vertical at manufacturer's recommended rate and allow to dry.
 2. Set cant in bitumen. Run all field plies over cant a minimum of 2 inches.
 3. Install base flashing ply covering curb with 6 inches on to the field of roof set in bitumen.
 4. The second ply shall be a modified flashing ply installed over the base flashing ply 9 inches on to field of roof set in bitumen. Attach top of membrane to top of three course application of mastic and mesh allowed to cure and topcoat.
 5. Install premanufactured counterflashing with fasteners and neoprene washers as specified in related section, or per manufacturer's recommendations otherwise.
 6. Set equipment on neoprene pad and fasten as required by equipment manufacturer.
- E. Reglet Mounted Counterflashing:
1. Prime vertical wall at manufacturer's recommended rate and allow to dry.
 2. Set cant in bitumen. Run all field plies over cant a minimum of 2 inches.
 3. Install base flashing ply covering wall, with 6 inches on to field of roof set in bitumen.
 4. The second ply shall be a modified flashing ply installed over the base flashing ply, 9 inches on to field of roof in bitumen. All vertical seams will receive a three course application of mastic and mesh allowed to cure and aluminize.
 5. Apply butyl tape to wall behind flashing. Secure termination bar through flashing, butyl tape and into wall.
 6. Secure reglet counterflashing with recommended fasteners and seal reglet opening.
- F. Heat Stack:
1. Minimum stack height is 8 inches above adjacent roof surface.
 2. Run roof system over the roof. Seal the base of the stack with elastomeric sealant.
 3. Prime flange of new sleeve. Install properly sized sleeves set in a 1/4 inch base of elastomeric sealant.
 4. Install base flashing ply in bitumen.
 5. Install modified membrane in bitumen.
 6. Seal the intersection of the membrane and the base flashing ply.
 7. Install new collar over cape. Weld collar or install stainless steel draw band.
- G. Plumbing Stack:
1. Minimum stack height is 8 inches above adjacent roof surface.
 2. Run roof system over the roof. Seal the base of the stack with elastomeric sealant.
 3. Prime flange of new sleeve. Install properly sized sleeves set in a 1/4 inch base of elastomeric sealant.
 4. Install base flashing ply in bitumen.
 5. Install modified membrane in bitumen.
 6. Caulk the intersection of the membrane and the base flashing with elastomeric sealant.
 7. Turn sleeve a minimum of 1 inch down inside of stack.
 8. Vandal-proof Vent Cap: Provide at all roof vent penetrations.
- H. Passive Vent/Air Intake / Fan Curb:
1. Minimum curb height is 8 inches. Prime vertical at manufacturer's recommended rate and allow to dry.
 2. Set cant in bitumen. Run all plies over cant a minimum of 2 inches.
 3. Install base flashing ply covering curb with 6 inches on to the field of roof.
 4. Install second modified flashing ply over the base flashing ply 9 inches on to field of roof set in bitumen. Attach top of membrane to top of curb and nail 8 inches on center. Apply three course application of mastic and mesh to all seams, cure and seal coat.

5. Place passive vent/air intake over the wood nailers and flashing to act as counterflashing. Fasten per manufacturer's recommendations and as specified in related section.

3.08 SURFACING - CONVENTIONAL APPLICATION

- A. Apply roof coatings in accordance with roofing and coating manufacturers' instructions.
- B. Install walkway pads by setting in roof cement. Set joints 6 inches apart.

3.09 FIELD QUALITY CONTROL

- A. See Section 01 4000 - Quality Requirements, for general requirements for field quality control and inspection.
- B. Require site attendance of roofing and insulation material manufacturers daily during installation of the Work.

3.10 CLEANING

- A. Remove bituminous markings from finished surfaces.
- B. In areas where finished surfaces are soiled by bitumen or other source of soiling caused by work of this section, consult manufacturer of surfaces for cleaning advice and conform to their documented instructions.
- C. Repair or replace defaced or damaged finishes caused by work of this section.

3.11 PROTECTION

- A. Protect installed roofing and flashings from construction operations.
- B. Where traffic must continue over finished roof membrane, protect surfaces using durable materials.

3.12 ROOFING INSTALLER'S WARRANTY

- A. WHEREAS _____ of _____, herein called the "Roofing Installer," has performed roofing and associated work ("work") on the following project:
 1. Owner: _____.
 2. Address: _____.
 3. Building Name/Type: _____.
 4. Address: _____.
 5. Area of Work: _____.
 6. Acceptance Date: _____.
 7. Warranty Period: **Two Years**.
 8. Expiration Date: _____.
- B. AND WHEREAS Roofing Installer has contracted (either directly with Owner or indirectly as a subcontractor) to warrant said work against leaks and faulty or defective materials and workmanship for designated Warranty Period,
- C. NOW THEREFORE Roofing Installer hereby warrants, subject to terms and conditions herein set forth, that during Warranty Period he will, at his own cost and expense, make or cause to be made such repairs to or replacements of said work as are necessary to correct faulty and defective work and as are necessary to maintain said work in a watertight condition.
- D. This Warranty is made subject to the following terms and conditions:
 1. Specifically excluded from this Warranty are damages to work and other parts of the building, and to building contents, caused by:
 - a. lightning;

- b. peak gust wind speed exceeding **90 MPH**;
 - c. fire;
 - d. failure of roofing system substrate, including cracking, settlement, excessive deflection, deterioration, and decomposition;
 - e. faulty construction of parapet walls, copings, chimneys, skylights, vents, equipment supports, and other edge conditions and penetrations of the work;
 - f. vapor condensation on bottom of roofing; and
 - g. activity on roofing by others, including construction contractors, maintenance personnel, other persons, and animals, whether authorized or unauthorized by Owner.
- 2. When work has been damaged by any of foregoing causes, Warranty shall be null and void until such damage has been repaired by Roofing Installer and until cost and expense thereof have been paid by Owner or by another responsible party so designated.
 - 3. Roofing Installer is responsible for damage to work covered by this Warranty but is not liable for consequential damages to building or building contents resulting from leaks or faults or defects of work.
 - 4. During Warranty Period, if Owner allows alteration of work by anyone other than Roofing Installer, including cutting, patching, and maintenance in connection with penetrations, attachment of other work, and positioning of anything on roof, this Warranty shall become null and void on date of said alterations, but only to the extent said alterations affect work covered by this Warranty. If Owner engages Roofing Installer to perform said alterations, Warranty shall not become null and void unless Roofing Installer, before starting said work, shall have notified Owner in writing, showing reasonable cause for claim, that said alterations would likely damage or deteriorate work, thereby reasonably justifying a limitation or termination of this Warranty.
 - 5. During Warranty Period, if original use of roof is changed and it becomes used for, but was not originally specified for, a promenade, work deck, spray-cooled surface, flooded basin, or other use or service more severe than originally specified, this Warranty shall become null and void on date of said change, but only to the extent said change affects work covered by this Warranty.
 - 6. Owner shall promptly notify Roofing Installer of observed, known, or suspected leaks, defects, or deterioration and shall afford reasonable opportunity for Roofing Installer to inspect work and to examine evidence of such leaks, defects, or deterioration.
 - 7. This Warranty is recognized to be the only warranty of Roofing Installer on said work and shall not operate to restrict or cut off Owner from other remedies and resources lawfully available to Owner in cases of roofing failure. Specifically, this Warranty shall not operate to relieve Roofing Installer of responsibility for performance of original work according to requirements of the Contract Documents, regardless of whether Contract was a contract directly with Owner or a subcontract with Owner's General Contractor.

E. IN WITNESS THEREOF, this instrument has been duly executed this _____ day of _____, _____.

- 1. Authorized Signature: _____.
- 2. Name: _____.
- 3. Title: _____.

END OF SECTION

SECTION 07 6200
SHEET METAL FLASHING AND TRIM

PART 1 GENERAL

1.01 SECTION INCLUDES

- A. Fabricated sheet metal items, including flashings, counterflashings, gutters, downspouts, and other items indicated in Schedule and as follows:
 - 1. Edge strip and flashing.
 - 2. Fascia and trim.
 - 3. Counterflashings for roof accessories, roof mounted equipment, vent stacks and similar items.
 - 4. Base flashing coverings.
 - 5. Lead flashing for bituminous membranes.
 - 6. Reglets and accessories.
 - 7. Plaster stops, terminations and miscellaneous custom shapes not otherwise provided by related section specifying plaster cladding.
- B. Sealants for joints within sheet metal fabrications.
- C. Foam Sealer tape for sheet metal and flashing applications.

1.02 RELATED REQUIREMENTS

- A. Section 06 1000 - Rough Carpentry: Wood curbs and nailers.
- B. Section 07 4113 - Metal Roof Panels
- C. Section 07 5200 - Modified Bitumen Roofing: Requirements for pre-installation conference
- D. Section 07 7100 - Roof Specialties: Manufactured copings, flashings, and expansion joint covers.
- E. Section 07 7200 - Roof Accessories: Manufactured metal roof curbs.
- F. Section 07 9200 - Joint Sealants: Sealing non-lap joints between sheet metal fabrications and adjacent construction.

1.03 REFERENCE STANDARDS

- A. ASTM A653/ A653M - Standard Specification for Steel Sheet, Zinc-Coated (Galvanized) or Zinc-Iron Alloy-Coated (Galvannealed) by the Hot-Dip Process.
- B. ASTM A792 Steel Sheet, Aluminum-Zinc Alloy-Coated, by the Hot-Dip Process
- C. ASTM B32 - Standard Specification for Solder Metal.
- D. ASTM B209 - Standard Specification for Aluminum and Aluminum-Alloy Sheet and Plate.
- E. ASTM B209M - Standard Specification for Aluminum and Aluminum-Alloy Sheet and Plate [Metric].
- F. ASTM B486 Paste Solder
- G. ASTM C920 - Standard Specification for Elastomeric Joint Sealants.
- H. ASTM D226/D226M - Standard Specification for Asphalt-Saturated Organic Felt Used in Roofing and Waterproofing.
- I. ASTM D2178/D2178M - Standard Specification for Asphalt Glass Felt Used in Roofing and Waterproofing.
- J. ASTM D4586/D4586M - Standard Specification for Asphalt Roof Cement, Asbestos-Free.

- K. California Code of Regulations, Title 24, Part 2, California Building Code (CBC), International Building Code
- L. California Code of Regulations, Title 24, Part 11 California Green Building Standards Code, "CAL-Green".
- M. FS QQ-L-201 Specification for Lead Sheet
- N. SMACNA (ASMM) - Architectural Sheet Metal Manual.
- O. WH Warnock Hersey International, Inc. Middleton, WI.
- P. FM Loss Prevention Data Sheet.
- Q. NRCA National Roofing Contractors Association - Roofing Manual.
- R. Manufacturer's recommendations and specifications.

1.04 SUBMITTALS

- A. See Section 01 3300 - Submittals, for submittal procedures.
- B. Shop Drawings: Indicate material profile, jointing pattern, jointing details, fastening methods, flashings, terminations, and installation details.
 - 1. Indicate type, gauge and finish of metal.
- C. Product data: Provide manufacturer's specification data sheets for each product. Demonstrate compliance with specified attributes:
 - 1. Submit color chart for prefinished materials.
 - 2. Metal material characteristics and installation recommendations.
- D. CAL-GREEN Submittals: Product Data - VOC Limits: For adhesives sealants, fillers, primers and coatings, documentation including printed statement of VOC contents, comply with limits specified in related section.
- E. Certification:
 - 1. Submit certification that metal and fastening system furnished is Tested and Approved by Factory Mutual for 1-90 Wind Up-Lift Requirements.
- F. Provide approval letters from metal manufacturer for use of their metal within this particular roofing system type.
- G. Proof of fabricator and installer qualifications.

1.05 QUALITY ASSURANCE

- A. Perform work in accordance with SMACNA Architectural Sheet Metal Manual requirements , except as otherwise indicated.
 - 1. Factory Mutual Approval Standard 4435.
- B. Contractor's Warranty: The Contractor shall provide the Owner with a notarized written warranty assuring that all sheet metal work including caulking and fasteners to be water-tight and secure for a period of five years from the date of final acceptance of the building. Warranty shall include all materials and workmanship required to repair any leaks that develop, and make good any damage to other work or equipment caused by such leaks or the repairs thereof.

1.06 DELIVERY, STORAGE, AND HANDLING

- A. Deliver materials in manufacturer's original, unopened containers or packages with labels intact and legible.

- B. Stack material to prevent twisting, bending, and abrasion, and to provide ventilation. Slope metal sheets to ensure drainage.
- C. Prevent contact with materials that could cause discoloration or staining.

PART 2 PRODUCTS

2.01 PERFORMANCE REQUIREMENTS

- A. VOC Limits for adhesives, sealants, fillers, primers and coatings . Comply with limits specified in related section.

2.02 SHEET MATERIALS

- A. Galvanized Steel: ASTM A 653/A 653M, with G90/Z275 zinc coating; minimum 0.02 inch thick base metal, minimum thickness 24 gauge and greater as required by referenced standards for specific applications indicated.
- B. Aluminum: ASTM B 209 (ASTM B 209M), 3105 alloy, H14 temper;.040 inch thick; anodized finish of color as selected unless noted otherwise.

2.03 UTILITY WALL PENETRATION FLASHINGS

- A. Prefabricated Facility Services Utility Penetration Flashings, sizes and profiles required to suit conditions.
- B. Manufacturer: Quickflash Weatherproofing Products, Inc., 4129 Wagon Trail Avenue, Las Vegas, Nevada 89118. Phone (702) 614-6100. Fax (702) 614-4090. Website www.quickflashproducts.com.
- C. Plumbing Flashing Panels:
 - 1. Panel: Combination of high-density polyethylene (HDPE) and low-density polyethylene (LDPE).
 - a. HDPE, Specific Gravity, ASTM D 1505: 0.953 g/cm³.
 - b. HDPE, Tensile Strength at Yield, ASTM D 638: 3,100 psi.
 - c. LDPE, Specific Gravity, ASTM D 792: 0.917 g/cm³.
 - d. LDPE, Tensile Strength at Yield, ASTM D 638: 1,300 psi.
 - 2. Weatherproof Seal: Thermoplastic elastomer.
 - a. Hardness, ASTM D 2240, Shore A, 10 Seconds: 46.
 - b. Specific Gravity, ASTM D 792: 1.05 g/cm³.
 - c. Tensile Strength, ASTM D 412: 490 psi.
- D. Electrical Flashing Panels:
 - 1. Material: Thermoplastic elastomer.
 - a. Hardness, ASTM D 2240, Shore A, 10 Seconds: 93.
 - b. Specific Gravity, ASTM D 792: 1.05 g/cm³.
 - c. Tensile Strength, ASTM D 412: 1,300 psi.

2.04 FABRICATION - GENERAL

- A. Fabricate in accordance with referenced standards. Form sections true to shape, accurate in size, square, and free from distortion or defects. Form pieces as recommended by SMACNA standard for conditions required.
 - 1. Provide reinforcements and supports as required for secure anchorage.
 - 2. Make joints rigid. Seams mechanically strong and soldered or sealed to make watertight
 - 3. Fabricate corners in one piece with legs extending 30-inches each way to field joint. Lap, rivet, and solder or seal corner seams watertight.
 - 4. Turn up "end dam" flanges at ends of opening sill flashing pieces, lap with wall flashing and membranes to shed water.
 - 5. Fabricate cleats of same material as sheet, minimum 3/4 inches wide, interlockable with sheet.

6. Hem exposed edges on underside 1/2 inch; miter and seam corners.
 7. Solvent clean all sheet metal. Coat surfaces to be in contact with roofing or otherwise concealed with specified asphaltic paint; 0.015-inch minimum uniform thickness.
- B. Fabricate cleats of same material as sheet, 1 gauge heavier, minimum 2 inches wide, interlocking with sheet.
 - C. Form pieces in longest possible lengths.
 - D. Machine-roll flashing elements and joinery required to be curved or radiused. Do not field bend or "walk-down". Provide true curves and joinery utilizing "Pittsburgh lock" construction, minimizing joints. Segmented fabrication is not acceptable unless specifically noted and dimensioned on drawings.
 - E. Hem exposed edges on underside 1/2 inch; miter and seam corners.
 - F. Form material with flat lock seams, except where otherwise indicated; at moving joints, use sealed lapped, bayonet-type or interlocking hooked seams.
 - G. Fabricate corners from one piece with minimum 18 inch long legs; seam for rigidity, seal with sealant.
 - H. Fabricate vertical faces with bottom edge formed outward 1/4 inch and hemmed to form drip.

2.05 ROOF-RELATED SHEET METAL AND FLASHINGS

- A. Roof-Related Sheet Metal and Flashings: As indicated, as specified in related sections, as required by roofing material manufacturers and referenced standards. Coordinate work of this section with related sections. Provide complete systems without conflict or omission.

2.06 GUTTER AND DOWNSPOUT FABRICATION

- A. Gutters: Profile as indicated. 20 gauge minimum.
 1. Expansion joints: Lap type; closed ends with cap over flanged tops of gutter ends.
- B. Gutters and Downspouts: Size indicated.
- C. Accessories: Profiled to suit gutters and downspouts.
 1. End caps, rain diverters, gutter straps support brackets, joint fasteners: Sized to suit gutters, of matching thickness.
 2. Anchorage Devices: In accordance with SMACNA (ASMM) requirements.
 3. Gutter Supports: Straps. Fabricate from material of double thickness of gutter fabrication, minimum.
 4. Downspout Supports: Straps. Fabricate from material of double thickness of gutter fabrication, minimum.
 5. Gutter Outlet Strainers: Stainless steel; Woven wire mesh type, #10 gauge, No.4 mesh minimum.
- D. Seal prefinished metal joints. Solder other joints.

2.07 ACCESSORIES

- A. Reinforcement Metals:
 1. Typical: Stainless steel or extruded aluminum.
 2. For copper work: Copper or Stainless Steel.
- B. Fasteners:
 1. Corrosion resistant screw fastener as recommended by metal manufacturer. Finish exposed fasteners same as flashing metal.
 2. Fastening shall conform to Factory Mutual 1-90 requirements or as stated on section details, whichever is more stringent.

3. Screws, bolts, washers, drive-ins.
 - a. For aluminum work: Stainless steel, aluminum, or zinc-aluminum alloy.
 - b. For galvanized steel work: Galvanized steel or cadmium plated steel.
 - c. For stainless steel work or dissimilar metals: Stainless steel.
 - d. For zinc alloy work: Steel, hot dip galvanized per ASTM A153, or stainless steel or aluminum.
 - e. For copper work: copper.
- C. Underlayment: Organic roofing felt, Type II ("No. 30").
- D. Primer: Galvanized iron type.
 1. Product: Rust-Oleum 7400 System, Modified Alkyd Zinc Primer, <340 g/l VOC: www.rustoleum.com.
 2. Substitutions: Section 01 6000.
- E. Sealant to be Concealed in Completed Work: Non-curing butyl sealant.
- F. Sealant to be Exposed in Completed Work: 1; elastomeric sealant, 100 percent silicone with minimum movement capability of plus/minus 25 percent and recommended by manufacturer for substrates to be sealed; clear.
- G. Flexible Flashing: 25 mil (0.64 mm), cold applied, self-adhering membrane consisting of a 3 mil (0.07 mm) high density, cross-laminated polyethylene film coated on one side with a 22 mil (0.56 mm) layer of rubberized asphalt adhesive; W. R. Grace "Vycor Plus".
- H. Sealer Tape: Medium Density Closed Cell EPDM or rubber blend tape single-coated with acrylic adhesive, for use in sheet metal and flashing applications.
 1. Width and Thickness: As required for snug fit under low compression to exclude moisture.
 2. Tensile Strength, ASTM D 412: 65 PSI.
 3. Pres-On; P9100, www.pres-on.com.
 4. 3M
 5. Argent; www.argent-international.com.
 6. Substitutions: See Section 01 6000 - Product Requirements.
- I. Plastic Cement: 1, Type I.
- J. Flux: FS O-F-506.
- K. Solder: ASTM B 32; Alloy Grade 50A.

PART 3 EXECUTION

3.01 EXAMINATION

- A. Verify roof openings, curbs, pipes, sleeves, ducts, and vents through roof are solidly set, reglets in place, and nailing strips located.
- B. Verify roofing termination and base flashings are in place, sealed, and secure.
- C. Beginning of installation means acceptance of existing conditions.
- D. Field measure site conditions prior to fabricating work.

3.02 PREPARATION

- A. Install starter and edge strips, and cleats before starting installation.
- B. Back paint concealed metal surfaces with protective backing paint to a minimum dry film thickness of 15 mil.

3.03 INSTALLATION

- A. Except as otherwise indicated, comply with manufacturer's installation instructions and recommendations and with SMACNA Architectural Sheet Metal Manual.
 - 1. Anchor units of work securely in place by methods indicated, providing for thermal expansion of units; conceal fasteners where possible, and set units true to line and level in locations indicated.
 - 2. Install work with laps, joints, and seams that will be permanently watertight and weatherproof.
- B. Install work watertight, without waves, warps, buckles, fastening stress, or distortion, allowing for expansion and contraction. Conform to referenced standards. Make metal joints watertight.
- C. Fastening of metal to walls and wood blocking shall comply with SMACNA Architectural Sheet Metal Manual, Factory Mutual 1-90 wind uplift specifications and/or manufacturer's recommendations whichever is of the highest standard.
- D. Underlayment: Where sheet metal installation occurs on cementitious or wood substrates, install roofing felt covered with slip sheet direct to substrate, do not allow sheet metal installation directly to concrete or wood.
- E. Coordinate sheet metal installation with roofing underlayment and air barrier and water-resistive barriers specified in related sections.
- F.
- G. All accessories or other items essential to the completeness of sheet metal installation and water tight envelope of the building, whether specifically indicated or not, shall be provided.
- H. Flashing: Joints at 10-foot maximum spacing and at 2-1/2-feet from corners. Butt joints with 3/16-inch space centered over matching 8-inch long backing plate with sealer tape in laps.
- I. Flanged flashings and roof accessories: Set on continuous sealer tape. Nail flanges through sealer tape and at 3-inch maximum spacing.
- J. Isolate metal from dissimilar metal with 2 coats of specified asphaltic paint, sealer tape or other approved coating, specifically made to stop electrolytic action. Use only stainless steel fasteners to connect isolated dissimilar metals.
- K. Joints, fastenings, reinforcements and supports: Sized and located as required to preclude distortion or displacement due to thermal expansion and contraction. Conceal fastenings wherever possible.
- L. Secure flashings in place using concealed fasteners, and use exposed fasteners only where permitted..
- M. Flexible Flashing Installation: Install at closure flanges, under metal copings, caps and platforms; fully adhered, free of voids, blisters and buckling.
 - 1. Prime substrates as recommended by flexible flashing manufacturer, allow to dry.
 - 2. Install flexible flashings in maximum feasible lengths to minimize lap joints.
 - 3. Peel release paper from roll to expose rubberized asphalt and position flashing to center over joint location before applying. Move along opening or joint, being careful to put flashing as evenly as possible over the opening. Avoid fishmouths.
 - 4. Press flashing firmly into place and roll using resilient roller with heavy hand pressure. Ensure continuous and intimate contact with substrate.
 - 5. If wrinkles develop, carefully cut out affected area and replace as outlined above.
 - 6. Minimize exposure time to that period recommended by the manufacturer.
- N. Apply plastic cement compound between metal flashings and felt flashings.
- O. Fit flashings tight in place; make corners square, surfaces true and straight in planes, and lines accurate to profiles.

- P. Seal prefinished metal joints watertight.
- Q. Solder other metal joints for full metal surface contact. After soldering, wash metal clean with neutralizing solution and rinse with water.
- R. Secure gutters and downspouts in place with concealed fasteners.
 - 1. Gutter support straps: Nail or screw into solid framing or blocking, 16 d minimum. Provide straps at 32 inches on center minimum, align with roof framing members where occurs.
 - 2. Gutters: Flash and seal gutters to downspouts and accessories.
 - 3. Leaf guards inside gutter at each downspout or rainwater leader opening.
- S. Slope gutters 1/4 inch per 10 feet, minimum.

3.04 OPENING FLASHING

- A. Flash all wall openings as follows.
 - 1. Install opening flashings after completion of air barriers.
 - 2. Install opening flashings (pre-molded corners and flexible flashings) in accordance with flexible flashing manufacturer's recommendations.
 - 3. Install premolded corner flashings at opening sill corners with nails or screws over layer of flexible flashing extended over face of sheathing and sill opening.
 - 4. Install flexible flashing across face of wall under opening, install additional layer as sill pan with ends turned up 3 inches, coordinate with weather-resistive barrier and jamb flashings to form water-shedding laps. Direct all water flow to exterior of building.
 - 5. Install flexible flashing at head and jamb under weather resistive barrier along opening header, coordinate to lap over sill pan described above, install flexible flashing across head of opening, extended past jamb flashings by 3 inches and secure with nails or screws to wall, fold weather resistive barrier down over head flashing and seal with tape.
 - 6. Flanged Fixtures (Window, Door, Louver, etc.): Set flanges of Head and Jamb in beads of sealant. Do not flash over bottom nailing flange. Do not seal bottom flange.

3.05 UTILITY WALL PENETRATION FLASHING INSTALLATION

- A. Select prefabricated facility services utility penetration flashing sizes and profiles required to suit conditions.
- B. Install in accordance with manufacturer's recommendations, properly lapped with weather resistive barrier and related flashing and finishes to shed water to the building exterior.

3.06 FIELD QUALITY CONTROL

- A. See Section 01 4000 - Quality Requirements, for field inspection requirements.
- B. Inspection will involve surveillance of work during installation to ascertain compliance with specified requirements.
- C. Tolerances
 - 1. Exposed surfaces: Free of dents, scratches, abrasions, or other visible defects; clean, ready for painting.
 - 2. Set flashings and sheet metal to straight, true lines with exposed faces aligned in plane as indicated.

3.07 SHOP FABRICATED SHEET METAL

- A. Installer shall be responsible for determining if the sheet metal systems are in general conformance with roof manufacturer's recommendations.

- B. Metal work shall be shop fabricated to configurations and forms in accordance with recognized sheet metal practices.
- C. Install sheet metal to comply with Architectural Sheet Metal manual, Sheet Metal and Air Conditioning Contractor's National Associations, Inc.
 - 1. Hem exposed edges.
 - 2. Angle bottom edges of exposed vertical surfaces to form drip.
 - 3. Lap all corners with adjoining pieces, fasten and set in sealant.
- D. Form Joints for continuous strip flashings with a 1/4 inch opening between sections. Cover opening with a cover plate or back with an internal drainage plate formed to the profile of flashing piece. Embed cover plate in mastic, fastened through the opening between the sections and loose locked to the drip edges.

3.08 MANUFACTURED SHEET METAL SYSTEMS

3.09 REPAIR AND RESTORATION

- A. Water Test Existing Gutters:
 - 1. Plug existing downspouts, fill existing gutters with water by hose.
 - 2. Allow filled gutters to rest for a period of 24 hours and observe for leaks.
 - 3. Mark all leaking locations for repair as specified below.
 - 4. For purposes of bidding, assume minimum one leak per thirty lineal feet of existing gutter.
- B. Prepare Existing Substrate(s): Scarify metal surfaces. Remove unbonded materials, sealants, and rust.
- C. Seal Leaks and Joints: Set 4 inch wide sheet metal cover plate, of same material and gauge as existing gutter, over inside of joint. Set cover plate in 4 beads of urethane sealant, two beads on each side of joint.

3.10 SCHEDULE

- A. Abbreviations:
 - 1. BUR = SBS Modified Membrane Roofing, type(s) specified in related section(s).
 - 2. AS = Asphalt Shingles, type(s) specified in related section(s).
- B. 24 ga. Galvanized Steel:
 - 1. Continuous Cleats/Hook Strips
 - 2. Securement Clips
 - 3. Siding stops and miscellaneous shapes as indicated.
 - 4. Stucco/Plaster Stops and miscellaneous shapes as indicated.
 - 5. Stucco/Plaster Termination Screeds, custom or specially formed types.
 - 6. BUR Counterflashings
 - 7. BUR, PVC Sleeper Covers
 - 8. BUR, PVC Curb Covers
 - 9. BUR Transition Flashings
 - 10. BUR Scuppers
 - 11. BUR, PVC, AS, RT Gutters and Gutter Expansion Joints
 - 12. BUR, PVC, AS, RT Downspout/Rainwater leader Inlets
- C. 24 ga. Galvalume Steel, Kynar 500 Coated, Color as selected:
 - 1. BUR, PVC Collector Boxes
- D. 20 ga. Galvanized Steel:
 - 1. Exhaust Fans
 - 2. Passive Vents

- E. Stainless Steel:
 - 1. Flashing in contact with aluminum items.
 - 2. Inlet sleeves at rainwater leaders to prevent contact with gutters of dissimilar metals.
 - 3. Sill pans at door and window openings.
- F. Lead Flashing:
 - 1. AS, RT Vent Pipe and Conduit Penetrations, 4 lb.
 - 2. BUR Interior Drain Flashings, Vent Pipe and Conduit Penetrations, 4 lb.
- G. Schedule 40 Steel Pipe:
 - 1. Rainwater leaders, types specified in Section 05 5000.
- H. Types not otherwise scheduled: As recommended by referenced standards for application or condition indicated.

END OF SECTION

SECTION 07 7100
ROOF SPECIALTIES

PART 1 GENERAL

1.01 SECTION INCLUDES

- A. Manufactured roof specialties, including copings and roof edge flashings, including reglets.
- B. Roof control and expansion joint covers.
- C. Pipe Penetration Curbs and Covers.
- D. Attic Vents.

1.02 RELATED REQUIREMENTS

- A. Pertinent Sections specifying Volatile Organic Compound (VOC) Content Restrictions.
- B. Pertinent Sections specifying Roofing and roof substrates.
- C. Section 07 9513 - Expansion Joint Cover Assemblies.
- D. Section 07 6200 - Sheet Metal Flashing and Trim.

1.03 REFERENCE STANDARDS

- A. AAMA 2605 - Voluntary Specification, Performance Requirements and Test Procedures for Superior Performing Organic Coatings on Aluminum Extrusions and Panels.
- B. ANSI/SPRI/FM 4435/ES-1 - Test Standard for Edge Systems Used with Low Slope Roofing Systems.
- C. NRCA (RM) - The NRCA Roofing Manual.
- D. California Code of Regulations, Title 24, Part 11 California Green Building Standards Code, "CAL-Green".
- E. California Code of Regulations, Title 24, Part 2, California Building Code (CBC), International Building Code, with California Amendments.
- F. SMACNA (ASMM) - Architectural Sheet Metal Manual.
- G. SMACNA (ASMM) - Architectural Sheet Metal Manual.

1.04 SUBMITTALS

- A. See Section 01 3300 - Submittals, for submittal procedures.
- B. Provide complete submittals at the same time as submittals for work in related sections to permit review of complete and integrated systems and assemblies.
- C. Product Data: For each type of product indicated. Include construction details, material descriptions, dimensions of individual components and profiles, and finishes, demonstrate compliance with specified attributes. Provide data on shape of components, materials and finishes, anchor types and locations.
- D. CAL-GREEN Submittals: Product Data - VOC Limits: For adhesives sealants, fillers, primers and coatings, documentation including printed statement of VOC contents, comply with limits specified in related section.

- E. Shop Drawings: Indicate configuration and dimension of components, adjacent construction, required clearances and tolerances, and other affected work. Include isometric details of corner and transition condition.
 - 1. Coping Layout Drawings: Dimension coping in maximum lengths recommended by manufacturer. Indicate butt joints or splices evenly spaced for each run of parapet wall. Balance joints and spaces visually in each run. Dimension equal legs on mitered corner pieces (interior and exterior corners). Request Architect approval of layout in writing on shop drawing.
- F. Samples: Submit two sample, 12 inch in length, illustrating component shape, finish, and color. Submit samples of factory fabricated transitions and intersections.
- G. Manufacturer's Installation Instructions: Indicate special procedures, fasteners, supporting members, and perimeter conditions requiring special attention.
- H. Warranty: Special warranty specified in this Section.
- I. Informational Submittals:
 - 1. Delegated-Design Submittal: For copings and roof edge flashings indicated to comply with performance requirements and design criteria, including analysis data signed and sealed by the qualified professional engineer responsible for their preparation.
 - 2. Professional Engineer Qualifications: Demonstrate compliance with specified requirements.

1.05 QUALITY ASSURANCE

- A. Professional Engineer Qualifications: A professional engineer who is legally qualified to practice in jurisdiction where Project is located and who is experienced in providing engineering services of the kind indicated. Engineering services are defined as those performed for installations of roof specialties that are similar to those indicated for this Project in material, design, and extent.
- B. Product Options: Information on Drawings and in Specifications establishes requirements for system's aesthetic effects and performance characteristics. Aesthetic effects are indicated by dimensions, arrangements, alignment, and profiles of components and assemblies as they relate to sightlines, to one another, and to adjoining construction. Performance characteristics are indicated by criteria subject to verification by one or more methods including preconstruction testing, field testing, and in-service performance.
 - 1. Do not modify intended aesthetic effects, as judged solely by Architect, except with Architect's approval. If modifications are proposed, submit comprehensive explanatory data to Architect for review.
- C. Perform work in accordance with SMACNA (ASMM) details.
- D. Installer Qualifications: Company specializing in performing the work of this section on projects of similar size and scope and approved by manufacturer.

1.06 COORDINATION

- A. Coordinate installation of manufactured roof specialties with interfacing and adjoining construction to provide a leakproof, secure, and noncorrosive installation.

1.07 WARRANTY

- A. Special Warranty on Painted Finishes: Manufacturer's standard form in which manufacturer agrees to repair finish or replace manufactured roof specialties that show evidence of deterioration of factory-applied finishes within specified warranty period.
 - 1. Fluoropolymer Finish: Deterioration includes, but is not limited to, the following:
 - a. Color fading more than 5 Hunter units when tested according to ASTM D 2244.
 - b. Chalking in excess of a No. 8 rating when tested according to ASTM D 4214.

- c. Cracking, checking, peeling, or failure of paint to adhere to bare metal.
2. Verify available warranties for finishes and insert number below. 20-year period is usually available for fluoropolymer finish and is maximum included with manufacturers' published data.
3. Finish Warranty Period: 20 years from date of Substantial Completion.

PART 2 PRODUCTS

2.01 PERFORMANCE REQUIREMENTS

- A. VOC Limits for adhesives sealants, fillers, primers and coatings. Comply with limits specified in related section.
- B. General: Manufacture and install manufactured roof specialties to resist thermally induced movement and exposure to weather without failing, rattling, leaking, or fastener disengagement.
- C. Delegated Design: Design copings and roof edge flashings, including comprehensive engineering analysis by a qualified professional engineer, using performance requirements and design criteria indicated.
- D. Edge Securement: Comply with CBC 1504.5 "Edge Securement for Low-Slope Roofs". Provide products tested for wind resistance in accordance with ANSI/SPRI ES-1, as required by the California Building Code, Chapter 15.
- E. Thermal Movements: Provide manufactured roof specialties that allow for thermal movements resulting from the following maximum change (range) in ambient and surface temperatures by preventing buckling, opening of joints, hole elongation, overstressing of components, failure of joint sealants, failure of connections, and other detrimental effects. Provide clips that resist rotation and avoid shear stress as a result of thermal movements. Base engineering calculation on surface temperatures of materials due to both solar heat gain and nighttime-sky heat loss.
 1. Temperature Change (Range): 120 deg F (67 deg C), ambient; 180 deg F (100 deg C), material surfaces.
- F. Water Infiltration: Provide manufactured roof specialties that do not allow water infiltration to building interior.
- G. Expansion Joint Covers: Flexible, waterproof, roof expansion joint assemblies, designed to permit plus or minus 50 percent dimensioned joint movement with full recovery, of fire-resistive capacity equal to adjacent roof/wall assemblies, compatible with adjacent systems and materials, internally drained with all collected water directed to the exterior.

2.02 COMPONENTS

- A. Roof Edge Flashings: Factory fabricated to sizes required; mitered, welded corners; concealed fasteners.
 1. Configuration: Fascia, cant, and edge securement for roof membrane.
 2. Pull-Off Resistance: Tested in accordance with ANSI/SPRI/FM 4435/ES-1 using test methods RE-1 and RE-2 to positive and negative design wind pressure as defined by applicable local building code.
 3. Material: Formed aluminum sheet, 0.050 inch thick, minimum.
 4. Finish: 70 percent polyvinylidene fluoride.
 5. Color: To be selected by Architect from manufacturer's standard range.
 6. Manufacturers:
 - a. W.P. Hickman Company; Extruded TerminEdge: www.wph.com.
 - b. Substitutions: See Section 01 6000 - Product Requirements.
- B. Copings: Factory fabricated to sizes required; mitered, welded corners; concealed fasteners.

1. Configuration: Concealed continuous hold down cleat at both legs; internal splice piece at joints of same material, thickness and finish as cap; concealed stainless steel fasteners.
 2. Mitered, welded corners to have equal dimension legs of manufacturer's minimum recommended length.
 3. Pull-Off Resistance: Tested in accordance with ANSI/SPRI/FM 4435/ES-1 using test method RE-3 to positive and negative design wind pressure as defined by applicable local building code.
 4. Snap-on Coping Anchor Plates: Concealed, stainless steel sheet, 12 inches (300 mm) wide, 0.028 inch (0.7 mm) thick, with integral cleats.
 5. Face Leg Cleats: Concealed, continuous stainless steel sheet.
 6. Internal Splice Plate with preformed channel, acting as a gutter chair to direct internal drainage to the exterior. Gauge and profile as recommended by manufacturer to suit conditions and loads indicated, stainless steel.
 7. Material: Formed aluminum sheet, 0.050 inch thick, minimum.
 8. Finish: Three coat 70 percent polyvinylidene fluoride.
 9. Color: To be selected by Architect from manufacturer's standard range.
 10. Manufacturers:
 - a. W.P. Hickman Company; PermaSnap 2 Coping: www.wph.com.
 - b. ATAS International, Inc.: Rapid-Lok coping: www.atas.com.
 - c. Substitutions: See Section 01 6000 - Product Requirements.
- C. Control and Expansion Joint Covers: Shapes and profiles as indicated, as required, and as recommended by manufacturer to suit application. Composite construction of flexible neoprene flashing of black color with closed cell urethane foam backing, each edge seamed to color coated galvanized steel sheet metal flanges, designed for nominal joint widths as indicated.
1. Include factory fabricated special formed corners, tees, intersections, and wall flashings, each sealed watertight.
 2. Products:
 - a. Johns Manville Corporation; Product Expand-o-Flash: www.jm.com.
 - b. Watson Bowman Acme: www.wabcorp.com.
 - c. Balco: www.balcousa.com.
 - d. Substitutions: See Section 01 6000 - Product Requirements.
- D. Flexible Internal Gutter: Flexible fabric reinforced neoprene profile meeting required joint movement criteria, capable of compressing without damage during full cycle of joint closure. Collects and drain moisture through internal flexible drain tube. Compatible with expansion joint systems by other manufacturers.
1. Gutter profile: 0.060 inch thick single ply reinforced EPDM sheet. Shore A hardness minimum 60 +/- 5, width of profile as required by joint type and movement requirements.
 2. Drain Tube: Provide 1-1/2 inch i.d. 1/8 inch wall clear PVC tubing.
 3. Transition element: premolded 0.060 inch EPDM taper profile with pre-taped flange and adhesive for bond to underside of gutter profile.
 4. Sealant: Types recommended by expansion joint manufacturer to suit application, compatible with adjacent substrates and roofing systems and approved by roofing manufacturer in writing.
 5. Products:
 - a. Watson Bowman Acme; Wabo@GutterFlex: www.wbacorp.com.
 - b. Substitutions: See Section 01 6000 - Product Requirements.
- E. Counterflashings and Reglets:
1. Counterflashings: Manufactured units in lengths not exceeding 12 feet (3.6 m) designed to snap into reglets and compress against base flashings with joints lapped, from the following exposed metal in thickness indicated:
 - a. Stainless Steel: 0.025 inch (0.64 mm) thick, No. 4 (bright, polished directional satin).

2. Reglets: Units of type, material, and profile indicated, formed to provide secure interlocking of separate reglet and counterflashing pieces and compatible with flashing indicated with factory-mitered and -welded corners and junctions. Manufactured units formed to provide secure interlocking of separate reglet and counterflashing pieces, and compatible with flashings indicated, from the following exposed metal in thickness indicated:
 - a. Stainless Steel: 0.025 inch (0.64 mm) thick, No. 4 (bright, polished directional satin).
 - b. For stucco application, with upturned fastening flange and extension leg of length to match thickness of applied finish materials.
 - c. For concrete application with temporary closure tape to keep reglet free of concrete materials, special fasteners for attaching reglet to concrete forms, and guides to ensure alignment of reglet section ends.
 3. Accessories:
 - a. Flexible-Flashing Retainer: Provide resilient plastic or rubber accessory to secure flexible flashing in reglet where clearance does not permit use of standard metal counterflashing or where Drawings show reglet without metal counterflashing.
 - b. Counterflashing Wind-Restraint Clips: Provide clips to be installed before counterflashing to prevent wind uplift of counterflashing lower edge.
 4. Products:
 - a. Cheney Flashing Company, Inc.: www.cheneyflashing.com.
 - b. Fry Reglet Corporation: www.fryreglet.com.
 - c. Hickman, W. P. Company: www.wph.com.
 - d. Substitutions: See Section 01 6000 - Product Requirements.
- F. Pipe Penetration Curbs: Pipe Penetration Curbs and Covers, locate at grouped pipe penetrations serving mechanical unit locations. Size as recommended by manufacturer to accommodate piping indicated and to minimize number of curb penetrations required. Field located to avoid conflicts with other systems.
1. Finish: Field Painted.
 2. Insulated Curb for Non-Insulated Roof Decks: Fully mitered 3 inch cant, welded 18 gauge galvanized steel shell and base plate, 1-1/2 inch thick 3-pound density rigid insulation, factory installed 2 x 2 wood nailer, reinforcing on sides 36 inches and greater.
 - a. ThyCurb Model TC-2.
 3. Graduated Pipe Boot Cover: ABS thermoplastic korad acrylic cover, graduated boots molded of weather-resistant Plastisol and (2) stainless steel pipe clamps per boot.
 - a. ThyCurb Model TCC-5.
 4. Manufacturer:
 - a. Thybar Corp/ThyCurb: www.thybar.com.
 - b. Substitutions: See Section 01 6000 - Product Requirements.

2.03 ACCESSORIES

- A. Sealant for Joints in Linear Components: As recommended by component manufacturer.
- B. Adhesive for Anchoring to Roof Membrane: Compatible with roof membrane and approved by roof membrane manufacturer.
- C. Fire barrier: Provide type required for indicated fire resistance and fabricated of layers of ceramic fiber insulation and metallic insulation.
- D. Fasteners, separators, sealants, and other miscellaneous items as recommended by required to complete manufactured roof specialty systems.
- E. Sealants: Silicone types as specified in Section 07 9005.

- F. Roof Cement and related materials as required for installation with products specified in related sections.

2.04 FINISHES

- A. PVDF (Polyvinylidene Fluoride) Coating: Superior Performance Organic Finish, AAMA 2605; multiple coat, thermally cured fluoropolymer finish system; color as indicated.

2.05 ACCESSORIES

- A. Sealant for Joints in Linear Components: As recommended by component manufacturer.
- B. Adhesive for Anchoring to Roof Membrane: Compatible with roof membrane and approved by roof membrane manufacturer.
- C. Fire barrier: Provide type required for indicated fire resistance and fabricated of layers of ceramic fiber insulation and metallic insulation.
- D. Fasteners, separators, and other miscellaneous items as recommended by required to complete manufactured roof specialty systems.
- E. Sealants: Silicone types as specified in Section 07 9200.
- F. Roof Cement and related materials as required for installation with products specified in related sections.

PART 3 EXECUTION

3.01 EXAMINATION

- A. Verify that deck, curbs, roof membrane, base flashing, and other items affecting work of this Section are in place and positioned correctly.

3.02 INSTALLATION

- A. Anchor manufactured roof specialties securely in place and capable of resisting forces specified in performance requirements. Use fasteners, separators, sealants, and other miscellaneous items as required to complete manufactured roof specialty systems.
 - 1. Install manufactured roof specialties with provisions for thermal and structural movement.
 - 2. Torch cutting of manufactured roof specialties is not permitted.
- B. Install components in accordance with manufacturer's instructions and NRCA (RM) applicable requirements.
- C. Conform to NRCA (RM) drawing details as noted:
- D. Metal Protection: Where dissimilar metals will contact each other or corrosive substrates, protect against galvanic action by painting contact surfaces with bituminous coating or by other permanent separation as recommended by manufacturer.
 - 1. Coat concealed side of manufactured roof specialties with bituminous coating where in contact with wood, ferrous metal, or cementitious construction.
 - 2. Underlayment: Where installing exposed-to-view components of manufactured roof specialties directly on cementitious or wood substrates, install a course of felt underlayment and cover with a slip sheet, or install a course of polyethylene underlayment.
- E. Coordinate installation of components of this section with installation of roofing membrane and base flashings.
- F. Coordinate installation of sealants and roofing cement with work of this section to ensure water tightness.

- G. Install manufactured roof specialties level, plumb, true to line and elevation, and without warping, jogs in alignment, excessive oil-canning, buckling, or tool marks.
- H. Install manufactured roof specialties to fit substrates and to result in watertight performance. Verify shapes and dimensions of surfaces to be covered before manufacture.
- I. Coordinate installation of flashing flanges into reglets .
- J. Fire rated joint Covers: Install to requirements of fire rated design. Install fire barriers and flame sealant as required to provide indicated fire rating.
- K. Align work plumb and level, flush with adjacent surfaces.
- L. Install flexible gutter profile continuous along length of joint with drain tube assemblies spaced 25 feet on center, minimum of two drains per joint. Install drain systems as recommended by manufacturer. Direct all collected moisture to exterior of building.
- M. Rigidly anchor to substrate to prevent misalignment.

3.03 COPING INSTALLATION

- A. Layout: Provide coping in maximum lengths recommended by manufacturer. Space butt joints or splices evenly for each run of parapet wall. Balance joints and spaces visually in each run.
- B. Install cleats, anchor plates, and other anchoring and attachment accessories and devices with concealed fasteners.
- C. Coordinate with roof membrane and exterior cladding air barrier installation to ensure continuity and membrane seal across top of parapet wall.
- D. Anchor copings to resist uplift and outward forces according to performance requirements.
 - 1. Interlock face and back leg drip edges of snap-on coping cap into cleated anchor plates anchored to substrate at manufacturer's recommended spacing.

3.04 COUNTERFLASHING AND REGLET INSTALLATION

- A. Counterflashings: Coordinate installation of counterflashings with installation of base flashings. Insert counterflashings in reglets or receivers and fit tightly to base flashings. Extend counterflashings 4 inches over base flashings. Lap counterflashing joints a minimum of 4 inches and bed with elastomeric sealant.

3.05 CLEANING AND PROTECTION

- A. Remove temporary protective coverings and strippable films as manufactured roof specialties are installed. On completion of installation, clean finished surfaces, including removing unused fasteners, metal filings, pop rivet stems, and pieces of flashing. Maintain in a clean condition during construction.
- B. Replace manufactured roof specialties that have been damaged or that cannot be successfully repaired by finish touchup or similar minor repair procedures.

3.06 SCHEDULES

- A. Fitness Buiding; All roof penetrations shall have 1-hour fire resistance rating including all expansion joints around grandstand support system. Basis of Design: Wabo FireFlex HFF + Wabo Flash ECF.

END OF SECTION

**SECTION 07 8400
FIRESTOPPING**

PART 1 GENERAL

1.01 SECTION INCLUDES

- A. Firestopping systems.
- B. Firestopping of all joints and penetrations in fire resistance rated and smoke resistant assemblies, whether indicated on drawings or not, and other openings indicated.

1.02 RELATED SECTIONS

- A. Section 01 6116 - Volatile Organic Compound (VOC) Content Restrictions.
- B. Section 01 7000 - Execution and Closeout Requirements: Cutting and patching.
- C. Section 09 2116 - Gypsum Board Assemblies: Gypsum wallboard fireproofing.
- D. Pertinent sections of other Divisions specifying work penetrating rated assemblies which require firestopping.

1.03 REFERENCE STANDARDS

- A. ASTM E119 - Standard Test Methods for Fire Tests of Building Construction and Materials.
- B. ASTM E814 - Standard Test Method for Fire Tests of Through-Penetration Fire Stops.
- C. ASTM E1966 - Standard Test Method for Fire Resistive Joint Systems.
- D. ASTM E2174 - Standard Practice for On-Site Inspection of Installed Firestops.
- E. ASTM E2393 - Standard Practice for On-Site Inspection of Installed Fire Resistive Joint Systems and Perimeter Fire Barriers.
- F. ASTM E2307 - Standard Test Method for Determining Fire Resistance of Perimeter Fire Barriers Using Intermediate-Scale, Multi-story Test Apparatus.
- G. ASTM E2837 - Standard Test Method for Determining the Fire Resistance of Continuity Head-of-Wall Joint Systems Installed Between Rated Wall Assemblies and Nonrated Horizontal Assemblies.
- H. ASTM G21 - Standard Practice for Determining Resistance of Synthetic Polymeric Materials to Fungi.
- I. ITS (DIR) - Directory of Listed Products.
- J. FM 4991 - Approval Standard for Firestop Contractors.
- K. FM (AG) - FM Approval Guide.
- L. ASTM C 518
- M. Manufacturer's recommendations for installation.
- N. SCAQMD 1168 - South Coast Air Quality Management District Rule No.1168.
- O. UL 2079 - Standard for Tests for Fire Resistance of Building Joint Systems.
- P. UL (DIR) - Online Certifications Directory.
- Q. UL (FRD) - Fire Resistance Directory.

1.04 SUBMITTALS

- A. See Section 01 3300 - Submittals, for submittal procedures.
- B. Schedule of Firestopping: List each type of penetration, fire rating of the penetrated assembly, firestopping test or design number, and certification that material is classified or listed for the type and size of void to be firestopped.
- C. Product Data: Provide data on product characteristics.
- D. Sustainable Design Submittal: Submit VOC content documentation for all non-preformed materials.
- E. Sketches indicating proposed methods of installation where not detailed on the Drawings.
- F. Manufacturer's Installation Instructions: Indicate preparation and installation instructions.
- G. Proof of applicator qualifications.
- H. Manufacturer's Certificate: Certify that products meet or exceed specified requirements.
- I. Certificate from authority having jurisdiction indicating approval of materials used.
- J. Installer Qualification: Submit qualification statements for installing mechanics.

1.05 QUALITY ASSURANCE

- A. Fire Testing: Provide firestopping assemblies of designs that provide the scheduled fire ratings when tested in accordance with methods indicated.
 - 1. Listing in UL (FRD), FM (AG), or ITS (DIR) will be considered as constituting an acceptable test report.
 - 2. Valid evaluation report published by ICC Evaluation Service, Inc. (ICC-ES) at www.icc-es.org will be considered as constituting an acceptable test report.
 - 3. Submission of actual test reports is required for assemblies for which none of the above substantiation exists.
- B. Manufacturer Qualifications: Company specializing in manufacturing the products specified in this section with minimum three years documented experience.
- C. Deliver materials in the original packages bearing the manufacturer's label showing classification or listing.
- D. Installer Qualifications: Company specializing in performing the work of this section with minimum three years experience and approved by the manufacturer.
 - 1. Trained by manufacturer.
 - 2. Approved by Factory Mutual Research Corporation under FM 4991, or meeting any two of the following requirements:
 - 3. Verification of minimum three years documented experience installing work of this type.
 - 4. Verification of at least five satisfactorily completed projects of comparable size and type.
 - 5. Licensed by local authorities having jurisdiction (AHJ).

1.06 FIELD CONDITIONS

- A. Comply with firestopping manufacturer's recommendations for temperature and conditions during and after installation. Maintain minimum temperature before, during, and for 3 days after installation of materials.
- B. Provide ventilation in areas where solvent-cured materials are being installed.

PART 2 PRODUCTS

2.01 MANUFACTURERS

- A. Firestopping Manufacturers:
 - 1. 3M Fire Protection Products: www.3m.com/firestop.
 - 2. A/D Fire Protection Systems Inc: www.adfire.com.
 - 3. Hilti, Inc: www.us.hilti.com/#sle.
 - 4. Substitutions: See Section 01 6000 - Product Requirements.

2.02 MATERIALS

- A. Volatile Organic Compound (VOC) Content: Provide products having VOC content lower than that required by SCAQMD 1168.
- B. Mold and Mildew Resistance: Provide firestopping materials with mold and mildew resistance rating of zero(0) in accordance with ASTM G21.
- C. Primers, Sleeves, Forms, Insulation, Packing, Stuffing, and Accessories: Provide type of materials as required for tested firestopping assembly.
- D. Fire Ratings: Refer to drawings for required systems and ratings.

2.03 FIRESTOPPING ASSEMBLY REQUIREMENTS

- A. Perimeter Fire Containment Firestopping: Use any system that has been tested according to ASTM E2307 to have fire resistance F Rating equal to required fire rating of the floor assembly.
 - 1. Movement: In addition, provide systems that have been tested to show movement capability as indicated.
 - 2. Temperature Rise: In addition, provide systems that have been tested to show T Rating as indicated.
 - 3. Air Leakage: In addition, provide systems that have been tested to show L Rating as indicated.
 - 4. Where floor assembly is not required to have a fire rating, provide systems that have been tested to show L Rating as indicated.
- B. Head-of-Wall Joint System Firestopping at Joints Between Fire-Rated Wall Assemblies and Non-Rated Horizontal Assemblies: Use any system that has been tested according to ASTM E2837 to have fire resistance F Rating equal to required fire rating of floor or wall, whichever is greater.
 - 1. Movement: In addition, provide systems that have been tested to show movement capability as indicated.
- C. Floor-to-Floor, Wall-to-Wall, and Wall-to-Floor Joints, Except Perimeter, Where Both Are Fire-Rated: Use any system that has been tested according to ASTM E1966 or UL 2079 to have fire resistance F Rating equal to required fire rating of the assembly in which the joint occurs.
 - 1. Movement: In addition, provide systems that have been tested to show movement capability as indicated.
 - 2. Air Leakage: In addition, provide systems that have been tested to show L Rating as indicated.
 - 3. Watertightness: In addition, provide systems that have been tested to show W Rating as indicated.
 - 4. Listing by FM (AG), ITS (DIR), UL (DIR), or UL (FRD) in their certification directories will be considered evidence of successful testing.
- D. Through Penetration Firestopping: Use any system that has been tested according to ASTM E814 to have fire resistance F Rating equal to required fire rating of penetrated assembly.
 - 1. Temperature Rise: In addition, provide systems that have been tested to show T Rating as indicated.
 - 2. Air Leakage: In addition, provide systems that have been tested to show L Rating as indicated.

3. Watertightness: In addition, provide systems that have been tested to show W Rating as indicated.
4. Listing by FM (AG), ITS (DIR), UL (DIR), or UL (FRD) in their certification directories will be considered evidence of successful testing.

2.04 FIRESTOPPING SYSTEMS

- A. Firestopping:
 1. As required by the proprietary U.L. or Warnock Hersey classification noted on the Drawings.
 2. If not specified by the classification, listed materials as here-in specified.
 3. Fire Ratings: See Drawings for required systems and ratings.

2.05 MATERIALS

- A. All materials Underwriters Laboratories Inc. (UL) or Warnock Hersey classified or listed as required to meet the appropriate firestop application.
- B. High-melt-point mineral wool or ceramic fiber, unfaced; Master Products "FireMaster Bulk".
 1. ASTM E84: Flame Spread 0; Smoke Development 0; Fuel Contributed 0.
 2. Non-combustible in accordance with ASTM E136.
- C. Gypsum board firestopping: ASTM C 36, Type X.
- D. Sealant, Fire-Retardant: 3M "Fire Dam 150", Dow Corning "Firestop" 2000", Hilti, Inc. "FS One", or approved equal for required fire rating. Color as selected by Architect from manufacturer's standards.
- E. Calcium silicate board: Promadeck as manufactured by Promat Fire Protection division of Eternit, Blandon, PA.; thickness as noted on the Drawings or as required by the tested assembly.
- F. Primers, Sleeves, Forms, Insulation, Packing, Stuffing, and Accessories: Type required for tested assembly design.
- G. Installation Accessories: Clips, collars, fasteners, temporary stops or dams, and other devices required to position and retain materials in place.
- H. Marking and Identification Tape: Pre-printed self-adhesive vinyl signage identifying fire and smoke assemblies, complying with CBC 703.7, designed to adhere to gypsum board surfaces. M&I Tape; Wege & Company, San Jose CA, www.wege.us.com.

PART 3 EXECUTION

3.01 EXAMINATION

- A. Verify openings are ready to receive the work of this section.

3.02 PREPARATION

- A. Clean substrate surfaces of dirt, dust, grease, oil, loose material, or other matter that could adversely affect bond of firestopping material.
- B. Remove incompatible materials that could adversely affect bond.
- C. Install backing or damming materials to arrest liquid material leakage.

3.03 INSTALLATION

- A. Install materials in manner described in fire test report and in accordance with manufacturer's instructions, achieving installation of required rating, completely closing openings.
- B. Do not cover installed firestopping until inspected by authorities having jurisdiction.
- C. Install labeling required by code.

1. Self-adhesive vinyl tape with identification of assembly as required by CBC 703.7.

3.04 FIELD QUALITY CONTROL

- A. Independent Testing Agency: Inspection agency employed and paid by Owner, will examine penetration firestopping in accordance with ASTM E2174, and ASTM E2393.
- B. Repair or replace penetration firestopping and joints at locations where inspection results indicate firestopping or joints do not meet specified requirements.

3.05 CLEANING

- A. Clean adjacent surfaces of firestopping materials.

3.06 PROTECTION

- A. Protect adjacent surfaces from damage by material installation.

END OF SECTION

SECTION 07 9200
JOINT SEALANTS

PART 1 GENERAL

1.01 SECTION INCLUDES

- A. Nonsag gunnable joint sealants.
- B. Self-leveling pourable joint sealants.
- C. Joint backings and accessories.

1.02 RELATED REQUIREMENTS

- A. Section 01 6116 - Volatile Organic Compound (VOC) Content Restrictions: Additional requirements for sealants and primers.
- B. Pertinent Sections specifying sealants or referencing this Section for sealant products and execution requirements.

1.03 REFERENCE STANDARDS

- A. ASTM C661 - Standard Test Method for Indentation Hardness of Elastomeric-Type Sealants by Means of a Durometer.
- B. ASTM C834 - Standard Specification for Latex Sealants.
- C. ASTM C920 - Standard Specification for Elastomeric Joint Sealants.
- D. ASTM C1193 - Standard Guide for Use of Joint Sealants.
- E. ASTM C1248 - Standard Test Method for Staining of Porous Substrate by Joint Sealants.
- F. ASTM D2240 - Standard Test Method for Rubber Property--Durometer Hardness.
- G. California Code of Regulations, Title 24, Part 11 California Green Building Standards Code, "CAL-Green".
- H. Manufacturer's recommendations and specifications.
- I. SWRI (VAL) - SWR Institute Validated Products Directory.

1.04 SUBMITTALS

- A. See Section 01 3300 - Administrative Requirements, for submittal procedures.
- B. Product Data for Sealants: Submit manufacturer's technical data sheets for each product to be used, that includes the following.
 - 1. Physical characteristics, including movement capability, VOC content, hardness, cure time, and color availability.
 - 2. List of backing materials approved for use with the specific product.
 - 3. Substrates that product is known to satisfactorily adhere to and with which it is compatible.
 - 4. Substrates the product should not be used on.
 - 5. Substrates for which use of primer is required.
 - 6. Substrates for which laboratory adhesion and/or compatibility testing is required.
 - 7. Installation instructions, including precautions, limitations, and recommended backing materials and tools.
 - 8. Sample product warranty.
 - 9. Certification by manufacturer indicating that product complies with specification requirements.

10. SWRI Validation: Provide currently available sealant product validations as listed by SWRI (VAL) for specified sealants.
- C. Product Data for Accessory Products: Submit manufacturer's technical data sheet for each product to be used, including physical characteristics, installation instructions, and recommended tools.
 1. Manufacturer's Installation Instructions: Indicate limitations, special procedures, surface preparation, and perimeter conditions requiring special attention.
 2. Sealant, Waterproofing, and Restoration Institute (SWRI) Validation Certificate: For each sealant specified to be validated by SWRI's Sealant Validation Program.
- D. Joint-Sealant Schedule: Include the following information:
 1. Joint-sealant application, joint location, and designation.
 2. Joint-sealant manufacturer and product name.
 3. Joint-sealant formulation.
 4. Joint-sealant colors (multiple colors will be required).
- E. Preconstruction Compatibility and Adhesion Test Reports: From sealant manufacturer, indicating the following:
 1. Materials forming joint substrates and joint-sealant backings have been tested for compatibility and adhesion with joint sealants.
 2. Interpretation of test results and written recommendations for primers and substrate preparation needed for adhesion.
- F. Color Cards for Selection: Where sealant color is not specified, submit manufacturer's color cards showing standard colors available for selection.
- G. Samples for Verification: Where custom sealant color is specified, obtain directions from Architect and submit at least two physical samples for verification of color of each required sealant.
- H. Sustainable Design Documentation: For sealants and primers, submit VOC content and emissions documentation as specified in Section 01 6116.
- I. Manufacturer Qualifications. Demonstrate compliance with specified requirements.
- J. Installer Qualifications. Demonstrate compliance with specified requirements.

1.05 QUALITY ASSURANCE

- A. Manufacturer Qualifications: Company specializing in manufacturing the products specified in this section with minimum three years documented experience.
- B. Installer Qualifications: Company specializing in performing the work of this section and with at least three years of documented experience.
- C. Manufacturer of sealant and caulking material to certify that cleaners, joint filler or bond breakers, and primers, for a particular application, are compatible with sealant.

1.06 MOCK-UP

- A. Mockups: Install sealant in mockups of assemblies specified in other Sections that are indicated to receive joint sealants specified in this Section. Use materials and installation methods specified in this Section.
- B. Construct mock-up with specified sealant types and with other components noted.
- C. Locate where directed.
- D. Mock-up may remain as part of the Work.

1.07 DELIVERY, STORAGE, AND HANDLING

- A. Comply with requirements of Section 01 6000.
- B. Deliver materials to Project site in original unopened containers or bundles with labels indicating manufacturer, product name and designation, color, expiration period for use, pot life, curing time, and mixing instructions for multi-component materials.
- C. Store and handle materials in compliance with manufacturer's recommendations to prevent their deterioration or damage due to moisture, high or low temperatures, contaminants, or other causes.

1.08 FIELD CONDITIONS

- A. Environmental Conditions: Do not proceed with installation of joint sealants under the following conditions:
 - 1. When ambient and substrate temperature conditions are outside the limits permitted by joint sealant manufacturer.
 - 2. When joint substrates are wet.
- B. Joint Width Conditions: Do not proceed with installation of joint sealants where joint widths are less than allowed by joint sealant manufacturer for application indicated.
- C. Joint Substrate Conditions: Do not proceed with installation of joint sealants until contaminants capable of interfering with their adhesion are removed from joint substrates.
- D. Maintain temperature and humidity recommended by the sealant manufacturer during and after installation.

1.09 COORDINATION

- A. Coordinate the work with all sections referencing this section.

1.10 WARRANTY

- A. See Section 01 7800 - Closeout Submittals, for additional warranty requirements.
- B. Correct defective work within a five year period after Date of Substantial Completion.
- C. Warranty: Include coverage for installed sealants and accessories that fail to achieve watertight seal, exhibit loss of adhesion or cohesion, or do not cure.

PART 2 PRODUCTS

2.01 SYSTEM DESCRIPTION

- A. Performance Requirements:
 - 1. Building envelope:
 - a. Make watertight and weathertight without causing staining or deterioration of joint substrates.
 - b. Exterior work that does not remain watertight and all work which does not retain all properties inherent in the product as stipulated by the manufacturer will be considered faulty.
- B. Building Exterior and Interior:
 - 1. Seal the following joints with joint sealer:
 - a. Expansion and control joints in exterior walls, copings, parapets.
 - b. Expansion and control joints in interior concrete slab floors.
 - c. Joints between metal panels.
 - d. Joints between door and window frames and adjacent materials.
 - e. Joints between cabinets and countertops and walls.

- f. Control joints in interior partitions, including portion above ceilings.
- g. Expansion and control joints in solid exterior soffits.
- h. Control joints in interior ceilings and soffits.
2. Apply continuous bead of joint sealer in the following locations during installation of materials specified elsewhere:
 - a. In lap joints of sheet metal construction.
 - b. Roofing panels and roof-related sheet metal and flashing.
 - c. Between partition floor and ceiling tracks and adjacent construction.
 - d. Between end stud of partition and adjacent construction.
 - e. Under door sills.
3. Acoustic Sealants at acoustic separations shall make assembly airtight.
 - a. Seal perimeter and intersections of finish.
 - b. Seal around electrical boxes and other penetrations of finish; seal holes within electrical boxes; seal conduit ends.
 - c. Seal pipes which penetrate acoustic separations.
4. Joints not specifically mentioned above which require sealants to meet the performance criteria cited in this section.

2.02 MATERIALS

- A. Sealants and Primers - General: Provide products having volatile organic compound (VOC) content as specified in Section 01 6116.
- B. Compatibility: Provide joint sealants, joint fillers, and other related materials that are compatible with one another and with joint substrates under conditions of service and application, as demonstrated by sealant manufacturer based on testing and field experience.
- C. Liquid-Applied Joint Sealants: Comply with ASTM C 920 and other requirements indicated for each liquid-applied joint sealant specified, including those referencing ASTM C 920 classifications for type, grade, class, and uses related to exposure and joint substrates.
- D. Stain-Test-Response Characteristics: Where sealants are specified to be nonstaining to porous substrates, provide products that have undergone testing according to ASTM C 1248 and have not stained porous joint substrates indicated for Project.
- E. Suitability for Contact with Food: Where sealants are indicated for joints that will come in repeated contact with food, provide products that comply with 21 CFR 177.2600.
- F. Colors: Provide color of exposed joint sealants to comply with the following:
 1. Provide colors matching selections made by Architect from manufacturer's full range of colors for products of type indicated. Colors may be listed in schedule at the end of this section or on the drawings. Request color selection for all products listed without a preselected color.

2.03 JOINT SEALANT APPLICATIONS

- A. Scope:
 1. Exterior Joints: Seal open joints, whether or not the joint is indicated on drawings, unless specifically indicated not to be sealed. Exterior joints to be sealed include, but are not limited to, the following items.
 - a. Wall expansion and control joints.
 - b. Joints between door, window, and other frames and adjacent construction.
 - c. Joints between different exposed materials.
 - d. Other joints indicated below.
 2. Interior Joints: Do not seal interior joints unless specifically indicated to be sealed. Interior joints to be sealed include, but are not limited to, the following items.

- a. Joints between door, window, and other frames and adjacent construction.
- b. Other joints indicated below.
3. Do not seal the following types of joints.
 - a. Intentional weepholes in window assemblies and head flashings.
 - b. Joints indicated to be treated with manufactured expansion joint cover or some other type of sealing device.
 - c. Joints where sealant is specified to be provided by manufacturer of product to be sealed.
 - d. Joints where installation of sealant is specified in another section.
 - e. Joints between suspended panel ceilings/grid and walls.

2.04 JOINT SEALANTS - GENERAL

- A. Sealants and Primers: Provide products with levels of volatile organic compound (VOC) content as indicated in Section 01 6116.
- B. Colors: As indicated on the drawings. If no colors are indicated, request colors before preparation of schedule submittals and include on all schedule submittals.

2.05 NONSAG JOINT SEALANTS

- A. Non-Staining Silicone Sealant: ASTM C920, Grade NS, Uses M and A; not expected to withstand continuous water immersion or traffic.
 1. Movement Capability: Plus and minus 50 percent, minimum.
 2. Non-Staining To Porous Stone: Non-staining to light-colored natural stone when tested in accordance with ASTM C1248.
 3. Dirt Pick-Up: Reduced dirt pick-up compared to other silicone sealants.
 4. Hardness Range: 15 to 35, Shore A, when tested in accordance with ASTM C661.
 5. Color: To be selected by Architect from manufacturer's standard range.
 6. Service Temperature Range: Minus 65 to 180 degrees F.
 7. Manufacturers:
 - a. Dow Corning Corporation; 790 Silicone Building Sealant: www.dowcorning.com/construction/#sle.
 - b. Pecora Corporation: www.pecora.com/#sle.
 - c. Sika Corporation; Sikasil WS-290: www.usa-sika.com/#sle.
 - d. Substitutions: See Section 01 6000 - Product Requirements.
- B. Silicone Sealant: ASTM C920, Grade NS, Uses M and A; not expected to withstand continuous water immersion or traffic.
 1. Movement Capability: Plus and minus 50 percent, minimum.
 2. Hardness Range: 15 to 35, Shore A, when tested in accordance with ASTM C661.
 3. Color: To be selected by Architect from manufacturer's standard range.
 4. Cure Type: Single-component, neutral moisture curing
 5. Service Temperature Range: Minus 65 to 180 degrees F.
 6. Manufacturers:
 - a. Dow Corning Corporation; 795: www.dowcorning.com.
 - b. Substitutions: See Section 01 6000 - Product Requirements.
- C. Silicone Sealant: ASTM C920, Type S, Grade NS, Class 25, single component, neutral curing, non-sagging, non-staining, non-bleeding, RTV silicone designed for adhesion to low energy surfaces common in sheet or peel-and-stick flexible flashings and air/weather barriers.
 1. Color: To be selected by Architect from manufacturer's standard range.
 2. Service Temperature Range: -65 to 180 degrees F.
 3. Products:
 - a. Dow Corning Corporation; 758: www.dowcorning.com.

- b. Sika Corporation, Construction Products Division; Sikasil-N.
 - c. Substitutions: See Section 01 6000 - Product Requirements.
- D. Mildew-Resistant Silicone Sealant: ASTM C920, Grade NS, Uses M and A, Class 25; single component, mildew resistant; not expected to withstand continuous water immersion or traffic.
- 1. Color: White.
 - 2. Manufacturers:
 - a. BASF Construction Chemicals-Building Systems; Omniplus: www.buildingsystems.basf.com.
 - b. Dow Corning Corporation; 786-M White.
 - c. GE Construction Sealants; SCS1700 Sanitary.
 - d. Pecora Corporation; ____: www.pecora.com/#sle.
 - e. Substitutions: See Section 01 6000 - Product Requirements.
- E. Type ___ - Polyurethane Sealant: ASTM C920, Grade NS, Uses M and A; single or multi-component; not expected to withstand continuous water immersion or traffic.
- 1. Movement Capability: Plus and minus 25 percent, minimum.
 - 2. Hardness Range: 20 to 35, Shore A, when tested in accordance with ASTM C661.
 - 3. Color: Custom as selected..
 - 4. Manufacturers:
 - a. BASF Building Systems, Sonolastic NP-2.
 - b. Sika Corporation; Sikaflex-2c NS: www.usa-sika.com/#sle.
 - c. Substitutions: See Section 01 6000 - Product Requirements.
- F. Polyurethane Sealant: ASTM C920, Grade NS, Uses M and A; single component; not expected to withstand continuous water immersion or traffic.
- 1. Movement Capability: Plus and minus 25 percent, minimum.
 - 2. Hardness Range: 20 to 35, Shore A, when tested in accordance with ASTM C661.
 - 3. Color: To be selected by Architect from manufacturer's standard range.
 - 4. Products:
 - a. BASF Building Systems, Sonolastic NP-1.
 - b. Sika Corporation; Sikaflex-1a: www.usa-sika.com.
 - c. Substitutions: See Section 01 6000 - Product Requirements.
- G. Acrylic Emulsion Latex: Water-based; ASTM C834, single component, non-staining, non-bleeding, non-sagging; not intended for exterior use, paintable.
- 1. Color: To be selected by Architect from manufacturer's standard range.
 - 2. Manufacturers:
 - a. BASF Construction Chemicals-Building Systems; Sonolac: www.buildingsystems.basf.com.
 - b. Pecora Corporation; ____: www.pecora.com/#sle.
 - c. Substitutions: See Section 01 6000 - Product Requirements.

2.06 SELF-LEVELING SEALANTS

- A. Self-Leveling Polyurethane Sealant: ASTM C920, Grade P, Uses M and A; single or multi-component; explicitly approved by manufacturer for traffic exposure; not expected to withstand continuous water immersion .
- 1. Movement Capability: Plus and minus 25 percent, minimum.
 - 2. Hardness Range: 35 to 55, Shore A, when tested in accordance with ASTM C661.
 - 3. Color: To be selected by Architect from manufacturer's standard range.
 - 4. Color at colored concrete: Custom-mixed colors matching colored concrete floors or paving.
 - 5. Service Temperature Range: Minus 40 to 180 degrees F.
 - 6. Manufacturers:

- a. BASF Construction Chemicals-Building Systems; Sonneborn SL-2 Slope Grade or Self Leveling Sealant: www.buildingsystems.basf.com.
 - b. Sika Corporation; Sikaflex-2c SL: www.usa-sika.com/#sle.
 - c. Substitutions: See Section 01 6000 - Product Requirements.
- B. Concrete Paving Joint Sealant: Polyurethane, pourable self-leveling; ASTM C920, Class 25, Uses T, I, M and A; multi- component.
1. Color: Custom mixed color matching colored concrete.
 2. Products:
 - a. BASF Construction Chemicals-Building Systems; Sonneborn SL-2: www.buildingsystems.basf.com.
 - b. Pecora Corporation; Dyna-Trol II-SG: www.pecora.com.
 - c. Sika Corporation, Construction Products Division; Sikaflex 2C-SL.
 - d. Substitutions: See Section 01 6000 - Product Requirements.
- C. Semi-Rigid Self-Leveling Epoxy Joint Filler: Epoxy or epoxy/polyurethane copolymer; intended for filling cracks and control joints not subject to significant movement; rigid enough to support concrete edges under traffic.
1. Meet requirements of American Concrete Institute 302.1 R-04 "Guide for Concrete Floor and Slab Construction" and American Concrete Institute 360 R10 "Guide to Design of Slabs-on-Ground" for industrial floor joint fillers
 2. Composition: Multi-component, 100 percent solids by weight.
 3. Hardness: Minimum of 85 (Shore A) or 35 (Shore D), when tested in accordance with ASTM D2240 after 7 days.
 4. Color: To be selected by Architect from manufacturer's standard colors.
 5. Joint Width, Minimum: 1/8 inch.
 6. Joint Width, Maximum: 1/4 inch.
 7. Joint Depth: Provide product suitable for joints from 1/8 inch to 2 inches in depth including space for backer rod.
 8. Manufacturers:
 - a. Euco 700 by The Euclid Chemical Company.
 - b. MM-80 by Metzger-McGuire.
 - c. W.R. Meadows, Inc; Rezi-Weld Flex: www.wrmeadows.com/#sle.
 - d. Substitutions: See Section 01 6000 - Product Requirements.

PART 3 EXECUTION

3.01 EXAMINATION

- A. Verify that joints are ready to receive work.
- B. Verify that backing materials are compatible with sealants.

3.02 PREPARATION

- A. Remove loose materials and foreign matter that could impair adhesion of sealant.
- B. Clean joints, and prime as necessary, in accordance with manufacturer's instructions.
- C. Perform preparation in accordance with manufacturer's instructions and ASTM C1193.
- D. Mask elements and surfaces adjacent to joints from damage and disfigurement due to sealant work; be aware that sealant drips and smears may not be completely removable.

3.03 INSTALLATION

- A. Perform work in accordance with sealant manufacturer's requirements for preparation of surfaces and material installation instructions.
- B. Perform installation in accordance with ASTM C1193.
- C. Measure joint dimensions and size joint backers to achieve width-to-depth ratio, neck dimension, and surface bond area as recommended by manufacturer, except where specific dimensions are indicated.
- D. Install bond breaker backing tape where backer rod cannot be used.
- E. Install sealant free of air pockets, foreign embedded matter, ridges, and sags, and without getting sealant on adjacent surfaces.
- F. Do not install sealant when ambient temperature is outside manufacturer's recommended temperature range, or will be outside that range during the entire curing period, unless manufacturer's approval is obtained and instructions are followed.
- G. Install sealants by proven techniques that result in sealants directly contacting and fully wetting joint substrates, completely filling recesses provided for each joint configuration, and providing uniform, cross sectional shapes and depths relative to joint widths that allow optimum sealant movement capability. Install sealants at the same time sealant backings are installed.
- H. Nonsag Sealants: Tool surface concave, unless otherwise indicated; remove masking tape immediately after tooling sealant surface.
 - 1. Immediately after sealant application and prior to time skinning or curing begins, tool sealants to form smooth, uniform beads of configuration indicated, to eliminate air pockets, and to ensure contact and adhesion of sealant with sides of joint. Remove excess sealants from surfaces adjacent to joint. Do not use tooling agents that discolor sealants or adjacent surfaces or are not approved by sealant manufacturer.
 - 2. Provide concave joint configuration per Figure 8A in ASTM C 1193, unless otherwise indicated.
 - 3. Provide flush joint configuration, per Figure 8B in ASTM C 1193, where indicated.
 - 4. Provide recessed joint configuration, per Figure 8C in ASTM C 1193, of recess depth and at locations indicated.
 - a. Use masking tape to protect adjacent surfaces of recessed tooled joints.
- I. Concrete Floor Joint Filler: After full cure, shave joint filler flush with top of concrete slab.

3.04 FIELD QUALITY CONTROL

- A. Perform field quality control inspection/testing as specified in PART 1 under QUALITY ASSURANCE article.
- B. Non-Destructive Adhesion Testing: If there are any failures in first 100 linear feet, notify Architect immediately.
- C. Destructive Adhesion Testing: If there are any failures in first 1000 linear feet, notify Architect immediately.
- D. Remove and replace failed portions of sealants using same materials and procedures as indicated for original installation.
- E. Repair destructive test location damage immediately after evaluation and recording of results.

3.05 FINISHING

- A. Work that is exposed to view: Uniform surface with neat, straight edges and no excess material on adjacent surface.

3.06 CLEANING

- A. Clean adjacent soiled surfaces.

3.07 PROTECTION

- A. Protect sealants until cured. Replace damaged work with repairs indistinguishable from original work.

3.08 SCHEDULE

- A. Architect will provide color selections and locations for each sealant type and for Contractor's use. Not all locations will have the same color.
 - 1. Custom colors will be required.
- B. Exterior Locations:
 - 1. Joints which are bordered by glass: Single-Component, Nonsag, Neutral-Curing Silicone Joint Sealant: ASTM C 920, Type S, Grade NS, Class 50, for Use NT.
 - 2. Joints which are bordered by plastic: Single-Component, Nonsag, Neutral-Curing Silicone Joint Sealant: ASTM C 920, Type S, Grade NS, Class 100/50, for Use NT.
 - 3. Horizontal joints in sidewalks, decks, concrete floors, and driveways: Exterior or Interior Horizontal Expansion Joint Sealant - Polyurethane, self-leveling; ASTM C 920, Grade P, Class 25, Uses T, M and A;single component.
 - a. At walk expansion joints.
 - b. Where walks abut structural slabs or stoops.
 - c. Where walks abut exterior wall of buildings.
 - d. Where exposed interior concrete slabs abut vertical surfaces.
 - e. Where sealant is shown on the Drawings for concrete slabs.
 - 4. Locations requiring adhesion to low energy surfaces common in sheet or peel-and-stick flexible flashings and air/weather barriers: ASTM C920, Type S, Grade NS, Class 25, single component, neutral curing, non-sagging, non-staining, non-bleeding, RTV silicone.
 - 5. Membrane Roofing Sealants: Types recommended by roofing manufacturer and complying with requirements of this section.
 - 6. Steep Slope Roofing Sealants: Types recommended by roofing manufacturer and complying with requirements of this section.
 - 7. Sheet Metal and Roof Accessory Sealants: Types recommended by roofing manufacturer and complying with requirements of this section.
 - 8. All other exterior joints including around perimeters of frames where door, window and louver frames abut concrete, masonry or other building materials (interior and exterior), Sills and thresholds, and at miscellaneous locations where sealant is shown on Drawings, exterior joints where no other sealant is indicated:
 - a. Multicomponent, Nonsag, Urethane Joint Sealant: ASTM C 920, Type M, Grade NS, Class 25, for Use NT, M, A and O; capable of 50% extension and compression movement.
 - b. Single-Component, Nonsag, Urethane Joint Sealant: ASTM C 920, Type S, Grade NS, Class 25, for Use NT.
 - 9. Exterior Sheet Metal Lap Joints: Types recommended by manufacturer and complying with requirements of this section.
 - 10. Exterior Metal Panel Butt Joints and trim: Types recommended by manufacturer and complying with requirements of this section.
- C. Interior Locations:
 - 1. Expansion and control joints, around perimeters of frames where door, window and louver frames abut concrete, masonry or other building materials, sills and thresholds, and at miscellaneous locations where sealant is shown on Drawings:

- a. Multicomponent, Nonsag, Urethane Joint Sealant: ASTM C 920, Type M, Grade NS, Class 25, for Use NT, M, A and O; capable of 50% extension and compression movement.
 - b. Single-Component, Nonsag, Urethane Joint Sealant: ASTM C 920, Type S, Grade NS, Class 25, for Use NT.
 2. Interior Concrete Slabs on Grade:
 - a. General Locations: Exterior or Interior Horizontal Expansion Joint Sealant: Polyurethane, self-leveling; ASTM C 920, Grade P, Class 25, Uses T, M and A; single component.
 3. Interior wet areas, around plumbing fixtures, countertops abutting walls, food service applications: Mildew-Resistant, Single-Component, Acid-Curing Silicone Joint Sealant: ASTM C 920, Type S, Grade NS, Class 25, for Use NT, A and O.
 4. Interior static dry joints as required to dress appearance, Other interior joints for which no other type of sealant is indicated.: Latex Joint Sealant: Acrylic latex or siliconized acrylic latex, ASTM C 834, Type OP, Grade NF.
 5. Where required for sound control: Acoustical Sealant, ASTM C-834.
 6. Where required for sound control with limited flame spread: Acoustical Sealant, ASTM C-834, fire-rated type.
- D. General:
1. Joints in construction between interior and exterior spaces and other designated or required locations to provide effective barrier against passage of elements, Other joints for which no other type of sealant is indicated.:
 - a. Multicomponent, Nonsag, Urethane Joint Sealant: ASTM C 920, Type M, Grade NS, Class 25, for Use NT, M, A and O; capable of 50% extension and compression movement.
 - b. Single-Component, Nonsag, Urethane Joint Sealant: ASTM C 920, Type S, Grade NS, Class 25, for Use NT.
 2. Specialty perimeters where required for appearance or weathertightness:
 - a. Multicomponent, Nonsag, Urethane Joint Sealant: ASTM C 920, Type M, Grade NS, Class 25, for Use NT, M, A and O; capable of 50% extension and compression movement.
 - b. Single-Component, Nonsag, Urethane Joint Sealant: ASTM C 920, Type S, Grade NS, Class 25, for Use NT.

3.09 POST-OCCUPANCY

- A. Post-Occupancy Inspection: Perform visual inspection of entire length of project sealant joints at a time that joints have opened to their greatest width; i.e. at low temperature in thermal cycle. Report failures immediately and repair.

END OF SECTION

**SECTION 07 9513
EXPANSION JOINT COVER ASSEMBLIES**

PART 1 GENERAL

1.01 SECTION INCLUDES

- A. Expansion joint cover assemblies for wall, ceiling, and soffit surfaces.

1.02 RELATED REQUIREMENTS

- A. Section 03 1000 - Concrete Forms and Accessories: Placement of joint assembly frames in formwork.
- B. Section 07 7100 - Roof Accessories: Roof expansion joints.
- C. Section 07 6200 - Sheet Metal Flashing and Trim: Roof expansion and control joint covers.
- D. Section 07 9200 - Joint Sealants: Sealing expansion and control joints using gunnable and pourable sealants.

1.03 REFERENCE STANDARDS

- A. ASTM B221 - Standard Specification for Aluminum and Aluminum-Alloy Extruded Bars, Rods, Wire, Profiles, and Tubes.
- B. ASTM B308/B308M - Standard Specification for Aluminum-Alloy 6061-T6 Standard Structural Profiles.
- C. ASTM E 119 - Standard Test Methods for Fire Tests of Building Construction and Materials

1.04 SUBMITTALS

- A. See Section 01 3300 - Submittals, for submittal procedures.
- B. Product Data: Provide joint assembly profiles, profile dimensions, anchorage devices and available colors and finish.
 - 1. Submit manufacturer's installation instructions and copies of UL Classification with California State Fire Marshal listing numbers for fire rated joint covers.
- C. Shop Drawings: Indicate joint and splice locations, miters, layout of the work, affected adjacent construction and anchorage locations.
- D. Samples: Submit two samples 10 inch long, illustrating profile, dimension, color, and finish selected.
- E. Manufacturer's Installation Instructions: Indicate rough-in sizes and required tolerances for item placement.

1.05 QUALITY ASSURANCE

- A. Provide systems by one manufacturer with a minimum of 5 years experience in fabrication of expansion joint systems.
- B. Fire rated joint covers shall have been tested by Underwriters Laboratories in accordance with ANSI/UL No. 263 and ASTM E 119, and the following criteria:
 - 1. In full-scale floor and wall furnaces.
 - 2. With positive furnace pressures.
 - 3. Passing both thermal conductivity and hose stream requirements.
 - 4. Minimum deflection withstood during fire tests:
 - 5. Wall systems: 4" deflection.
- C. Field Measurements: Verify compliance with manufacturer's requirements.

1.06 EXTRA MATERIALS

- A. See Section 01 6000 - Product Requirements, for additional provisions.
- B. Provide 18 ft of resilient joint filler and special tools required for accessing and servicing components.

PART 2 PRODUCTS

2.01 MANUFACTURERS

2.02 EXPANSION JOINT COVER ASSEMBLIES

- A. Expansion Joint Cover Assemblies - General: Factory-fabricated and assembled; designed to completely fill joint openings, sealed to prevent passage of air, dust, water, smoke; suitable for traffic expected.
 - 1. Joint Dimensions and Configurations: As indicated on drawings.
 - 2. Joint Cover Sizes: Selected to suit joint width and configuration, based on manufacturer's published recommendations and limitations.
 - 3. Lengths: Provide covers in full lengths required; avoid splicing wherever possible.
 - 4. Anchors, Fasteners, and Fittings: Provided by cover manufacturer.

2.03 MATERIALS

- A. Expansion Joint Covers: Shapes and profiles as indicated, as required, and as recommended by manufacturer to suit application. Fire rated assembly to match rating of walls, extruded aluminum, ASTM B221.
- B. Resilient Filler: Type appropriate for installation.
- C. Threaded Fasteners: Compatible with adjacent materials, sized as recommended by manufacturer in writing for proposed loading and use.
- D. Backing Paint: Asphaltic type.
- E. Fire barrier: Provide type required for indicated fire resistance and fabricated of layers of ceramic fiber insulation, metallic insulation.
- F. Flexible secondary internal gutter: Manufacturer's standard design accommodating required joint movement and compress without damage during full joint closure. Contain and drain excess collected moisture to building exterior through drainage tubes of similar flexibility. Minimize material elongation from moisture or debris. Secure to foundation using blockouts for joint or other manufacturer approved method.
 - 1. Wabo flexible Gutter System by Watson Bowman Acme, types to suit application.
 - 2. Gutter profile: 0.060 inch thick single ply reinforced EPDM sheet. Shore A hardness minimum 60 +/- 5, width of profile as required by joint type and movement requirements.
 - 3. Drain Tube: Provide 1-1/2 inch i.d. 1/8 inch wall clear PVC tubing.
 - 4. Transition element: premolded 0.060 inch EPDM taper profile with pre-taped flange and adhesive for bond to underside of gutter profile.
- G. Accessories, and other materials required for complete installation.

2.04 FABRICATION

- A. Joint Covers: Aluminum cover plate, aluminum frame construction, retainers with resilient elastomeric filler strip, designed to permit plus or minus 50 percent joint movement with full recovery, flush mounted.
 - 1. Fabricate special transitions, corner fittings, and end closures. Miter and weld joints
- B. Back paint components in contact with cementitious materials.

- C. Galvanize embedded ferrous metal anchors and fastening devices.
- D. Shop assemble components and package with anchors and fittings.
- E. Provide joint components in single length wherever practical. Minimize site splicing.
- F. Insulation blanket and fire-resistive sealant as recommended by manufacturer to achieve indicated fire ratings.

2.05 FINISHES

- A. Walls and Ceilings: Clear anodized.
- B. Resilient Filler Exposed to View: Black.

PART 3 EXECUTION

3.01 EXAMINATION

- A. Verify that joint preparation and dimensions are acceptable and in accordance with manufacturer's requirements.

3.02 PREPARATION

- A. Provide anchoring devices for installation and embedding .
 - 1. Provide templates and rough-in measurements.
- B. All surfaces to receive elastomeric compression seal shall be free from dirt, water, frost and any other loose foreign debris, which may be detrimental to effective joint sealing.
- C. Remove any and all accumulated debris from interstitial spaces before enclosure.

3.03 INSTALLATION

- A. Install components and accessories in accordance with manufacturer's instructions.
 - 1. Calculate and make allowances for change in joint size due to difference between installation and building operating temperatures
- B. Fire rated joint Covers: Install to requirements of fire rated design. Install fire barriers and flame sealant as required.
- C. Align work plumb and level, flush with adjacent surfaces.
- D. Elastomeric Compression Seals: Install utilizing manufacturer's lubricant adhesive. Utilize manufacturer's specialized installation tool as required to obtain specified fit and alignment.
- E. Install flexible gutter profile continuous along length of joint with drain tube assemblies spaced 25 feet on center, minimum of two drains per joint. Install drain systems as recommended by manufacturer. Direct all collected moisture to exterior of building.
- F. Rigidly anchor to substrate to prevent misalignment.

3.04 PROTECTION

- A. Do not permit traffic over unprotected floor joint surfaces.
- B. Provide strippable coating to protect finish surface.
- C. Where necessary, remove and store cover plate and install temporary protection over joints; reinstall cover plate before completion of work.
- D. Protect system and its components during construction. After work is complete in adjacent areas clean exposed surfaces with a suitable cleaner that will not harm or attack the elastomeric material.

3.05 SCHEDULE

- A. Fitness Building: All roof/ceiling expansion joints shall be 1-hour rated.

END OF SECTION

**SECTION 08 1113
HOLLOW METAL DOORS AND FRAMES**

PART 1 GENERAL

1.01 SECTION INCLUDES

- A. Non-fire-rated hollow metal doors and frames.
- B. Fire-rated hollow metal doors and frames.
- C. Thermally insulated hollow metal doors with frames.
- D. Hollow metal borrowed lites glazing and window frames.
- E. Accessories, including glazing, louvers, and matching panels.

1.02 RELATED REQUIREMENTS

- A. Section 08 7100 - DOOR HARDWARE.
- B. Section 08 8000 - Glazing: Glass for doors and borrowed lites.

1.03 ABBREVIATIONS AND ACRONYMS

- A. ANSI - American National Standards Institute.
- B. NFPA - National Fire Protection Association.
- C. SDI - Steel Door Institute.
- D. UL - Underwriters Laboratories.

1.04 DEFINITIONS

- A. Exterior doors: Doors exposed in whole or in part to the weather.
- B. Wet Areas: Exposed in whole or in part to areas where water is used in the room; toilets, custodial closets, food service, science classrooms, locker rooms and showers.

1.05 REFERENCE STANDARDS

- A. ADA Standards - Americans with Disabilities Act (ADA) Standards for Accessible Design.
- B. ANSI/SDI A250.4 - Test Procedure and Acceptance Criteria for Physical Endurance for Steel Doors, Frames and Frame Anchors.
- C. ANSI/SDI A250.8 - Specifications for Standard Steel Doors and Frames (SDI-100).
- D. ASTM A653/A653M - Standard Specification for Steel Sheet, Zinc-Coated (Galvanized) or Zinc-Iron Alloy-Coated (Galvannealed) by the Hot-Dip Process.
- E. ASTM A1008/A1008M - Standard Specification for Steel, Sheet, Cold-Rolled, Carbon, Structural, High-Strength Low-Alloy, High-Strength Low-Alloy with Improved Formability, Solution Hardened, and Bake Hardenable.
- F. ASTM A1011/A1011M - Standard Specification for Steel, Sheet and Strip, Hot-Rolled, Carbon, Structural, High-Strength Low-Alloy, High-Strength Low-Alloy with Improved Formability, and Ultra-High Strength.
- G. BHMA A156.115 - American National Standard for Hardware Preparation in Steel Doors and Steel Frames.

- H. ICC A117.1 - Accessible and Usable Buildings and Facilities.
- I. ITS (DIR) - Directory of Listed Products.
- J. NAAMM HMMA 830 - Hardware Selection for Hollow Metal Doors and Frames.
- K. NAAMM HMMA 831 - Hardware Locations for Hollow Metal Doors and Frames.
- L. NAAMM HMMA 840 - Guide Specifications for Installation and Storage of Hollow Metal Doors and Frames.
- M. NAAMM HMMA 861 - Guide Specifications for Commercial Hollow Metal Doors and Frames.
- N. NFPA 80 - Standard for Fire Doors and Other Opening Protectives.
- O. NFPA 105 - Standard for Smoke Door Assemblies and Other Opening Protectives.
- P. NFPA 252 - Standard Methods of Fire Tests of Door Assemblies.
- Q. SDI 117 - Manufacturing Tolerances for Standard Steel Doors and Frames.
- R. UL (DIR) - Online Certifications Directory.
- S. UL 10C - Standard for Positive Pressure Fire Tests of Door Assemblies.
- T. UL 1784 - Standard for Air Leakage Tests of Door Assemblies.

1.06 SUBMITTALS

- A. See Section 01 3300 - Submittals, for submittal procedures.
- B. Product Data: Materials and details of design and construction, hardware locations, reinforcement type and locations, anchorage and fastening methods, and finishes; and one copy of referenced standards/guidelines.
- C. Shop Drawings: Details of each opening, showing elevations, glazing, frame profiles, and any indicated finish requirements.
- D. Installation Instructions: Manufacturer's published instructions, including any special installation instructions relating to this project.
- E. Certificates: Provide manufacturer's certification of the following:
 - 1. Products comply with referenced standards.
 - 2. Each and every frame and hollow metal window, sidelite provided are UL listed and labeled for the fire rating indicated at the sizes shown.

1.07 QUALITY ASSURANCE

- A. Maintain at project site copies of reference standards relating to installation of products specified.

1.08 DELIVERY, STORAGE, AND HANDLING

- A. Comply with NAAMM HMMA 840 or ANSI/SDI A250.8 (SDI-100) in accordance with specified requirements.
- B. Protect with resilient packaging; avoid humidity build-up under coverings; prevent corrosion and adverse effects on factory applied painted finish.

PART 2 PRODUCTS

2.01 MANUFACTURERS

- A. Hollow Metal Doors and Frames:

1. Ceco Door, an Assa Abloy Group company: www.assaabloydss.com.
2. Republic Doors, an Allegion brand: www.republicdoor.com/#sle.
3. Republic Doors: www.republicdoor.com.
4. Steelcraft, an Allegion brand: www.allegion.com/us.
5. Substitutions: See Section 01 6000 - Product Requirements.

2.02 DESIGN CRITERIA

- A. Requirements for Hollow Metal Doors and Frames:
1. Steel used for fabrication of doors and frames shall comply with one or more of the following requirements; Galvannealed steel conforming to ASTM A653/A653M, cold-rolled steel conforming to ASTM A1008/A1008M, or hot-rolled pickled and oiled (HRPO) steel conforming to ASTM A1011/A1011M, Commercial Steel (CS) Type B for each.
 2. Accessibility: Comply with ICC A117.1 and ADA Standards.
 3. Exterior Door Top Closures: Flush end closure channel, with top and door faces aligned.
 4. Door Edge Profile: Hinged edge square, and lock edge beveled.
 5. Typical Door Face Sheets: Flush. Refer to Door Schedule for additional information.
 6. Glazed Lights: Non-removable stops on non-secure side; sizes and configurations as indicated on drawings. Style: Flush.
 7. Hardware Preparations, Selections and Locations: Comply with NAAMM HMMA 830 and NAAMM HMMA 831 or BHMA A156.115 and ANSI/SDI A250.8 (SDI-100) in accordance with specified requirements.
 8. Zinc Coating for Typical Interior and/or Exterior Locations: Provide metal components zinc-coated (galvanized) and/or zinc-iron alloy-coated (galvannealed) by the hot-dip process in accordance with ASTM A653/A653M, with manufacturer's standard coating thickness, unless noted otherwise for specific hollow metal doors and frames.
 - a. A60/ZF180 (galvannealed).
- B. Hollow Metal Panels: Same construction, performance, and finish as doors.
- C. Combined Requirements: If a particular door and frame unit is indicated to comply with more than one type of requirement, comply with the specified requirements for each type; for instance, an exterior door that is also indicated as being sound-rated must comply with the requirements specified for exterior doors and for sound-rated doors; where two requirements conflict, comply with the most stringent.
- D. Fire-rated Assemblies: Manufactured in accordance with Underwriters Laboratories Inc. or other approved independent testing laboratory and bearing their metal label affixed to both door and frame. Labels shall list fire rating and "UL 10B and 10C POSITIVE PRESSURE" label. Door labels shall also include smoke and draft "S" designation.
1. Manufacture in accordance with positive pressure test, UL-10C.
 2. Comply with ITS/Warnock Hersey International "Category A Doors". Where intumescent edge seals are required on wood or composite doors installed in steel frames, seal shall be built-in edge type. Edge seals are not allowed on frame. Only smoke and draft seals complying with the "S" rating are allowed to be installed on the frame.
 3. Coordinate with specification Section 08 7100 Door Hardware as required for compliance with UL 10C test, positive pressure fire-rated components and fire door assemblies.

2.03 HOLLOW METAL DOORS

- A. Door Finish: Factory primed and field finished.
- B. Exterior Doors: Thermally insulated.
1. Based on SDI Standards: ANSI/SDI A250.8 (SDI-100).
 - a. Level 3 - Extra Heavy-duty.

- b. Physical Performance Level A, 1,000,000 cycles; in accordance with ANSI/SDI A250.4.
- c. Model Types as indicated on Drawings.
- d. Door Face Metal Thickness: 16 gage, 0.053 inch, minimum.
- e. Zinc Coating: A60/ZF180 galvanized coating; ASTM A653/A653M.
2. Core Material: Vertical steel stiffeners with fiberglass batts.
3. Door Thermal Resistance: R-Value of ____.
4. Door Thickness: 1-3/4 inch, nominal.

C. Interior Doors, Non-Fire Rated:

1. Based on SDI Standards: ANSI/SDI A250.8 (SDI-100).
 - a. Level 3 - Extra Heavy-duty.
 - b. Physical Performance Level A, 1,000,000 cycles; in accordance with ANSI/SDI A250.4.
 - c. Model Types as indicated on Drawings.
 - d. Door Face Metal Thickness: 16 gage, 0.053 inch, minimum.
 - e. Zinc Coating: A60/ZF180 galvanized coating; ASTM A653/A653M at wet areas (toilet rooms, custodial, food service, locker and shower rooms).
2. Core Material: Manufacturers standard core material/construction and in compliance with requirements.
3. Door Thickness: 1-3/4 inch, nominal.

D. Fire-Rated Doors:

1. Based on SDI Standards: ANSI/SDI A250.8 (SDI-100).
 - a. Level 3 - Extra Heavy-duty.
 - b. Physical Performance Level A, 1,000,000 cycles; in accordance with ANSI/SDI A250.4.
 - c. Model Types as indicated on Drawings.
 - d. Door Face Metal Thickness: 16 gage, 0.053 inch, minimum.
 - e. Zinc Coating: A60/ZF180 galvanized coating; ASTM A653/A653M at wet areas (toilet rooms, custodial, food service, locker and shower rooms).
2. Fire Rating: As indicated on Door Schedule, tested in accordance with UL 10C and NFPA 252 ("positive pressure fire tests").
 - a. Temperature-Rise Rating (TRR) Across Door Thickness: In accordance with local building code and authorities having jurisdiction.
 - b. Provide units listed and labeled by UL (DIR) or ITS (DIR).
 - c. Attach fire rating label to each fire rated unit.
 - d. Smoke and Draft Control Doors (Indicated with letter "S" on Drawings and/or Door Schedule): Self-closing or automatic closing doors in accordance with NFPA 80 and NFPA 105, with fire-resistance-rated wall construction rated the same or greater than the fire-rated doors, and the following;
 - 5) Maximum Air Leakage: 3.0 cfm/sq ft of door opening at 0.10 inch w.g. pressure, when tested in accordance with UL 1784 at both ambient and elevated temperatures.
 - 6) Gasketing: Provide gasketing or edge sealing as necessary to achieve leakage limit.
 - 7) Label: Include the "S" label on fire-rating label of door.
3. Core Material: Manufacturers standard core material/construction in compliance with requirements.
4. Door Thickness: 1-3/4 inch, nominal.

2.04 HOLLOW METAL DOOR AND WINDOW FRAMES

- A. Comply with standards and/or custom guidelines as indicated for corresponding door in accordance with applicable door frame requirements.
- B. Frame Finish: Factory primed and field finished.

- C. Exterior Door Frames: Full profile/continuously welded type.
 - 1. Galvanizing: Components hot-dipped zinc-iron alloy-coated (galvannealed) in accordance with ASTM A653/A653M, with A40/ZF120 coating.
 - 2. Frame Metal Thickness: 12 gage, 0.093 inch, minimum.
 - 3. Weatherstripping: Separate, see Section 08 7100.
- D. Interior Door Frames, Non-Fire Rated: Full profile/continuously welded type.
 - 1. Terminated Stops: Provide at interior doors; closed end stop terminated 6 inch, maximum, above floor at 45 degree angle.
 - 2. Frame Metal Thickness: 14 gage, 0.067 inch, minimum.
- E. Door and Window Frames, Fire-Rated: Full profile/continuously welded type.
 - 1. Fire Rating: Same as door, labeled.
 - 2. Frame Metal Thickness: 16 gage, 0.053 inch, minimum.
- F. Borrowed Lites Glazing Frames: Construction and face dimensions to match door frames, and as indicated on drawings.
- G. Transom Bars: Fixed, of profile same as jamb and head.
- H. Provide mortar guard boxes for hardware cut-outs in frames to be installed in masonry or to be grouted.
- I. Frame Anchors: Furnished type of anchorage accepted by the Steel Door Institute. For wall conditions that do not permit installation of floor anchors furnish 1 additional wall anchor.
 - 1. Floor anchors: Furnish 1 per jamb. Minimum 16 gauge galvanized steel. Type with 2 bolts to structure.
 - 2. Jamb anchors:
 - a. Stud Partitions: Furnish 4 per jamb. Minimum 18 gauge and welded inside each jamb.

2.05 FRAME FABRICATION

- A. Cut-out, reinforce, punch and tap for mortise hardware. Where frames are grouted fabricate mortises in frames with mortar-tight back cover. Punch frames and provide silencers except where scheduled to have door seals.
- B. Reinforce for surface hardware. Reinforce in accordance with ANSI A115 and SDI-107 except as specified for material gauge.
 - 1. Hinge: No. 7 gauge; 1-1/4-inch by 10-inch, minimum.
 - 2. Strikes: No. 16 gauge formed combination reinforcement and dust cover.
 - 3. Flush bolts, closers, and other surface mounted hardware: No. 12 gauge.

2.06 ACCESSORIES

- A. Louvers: Roll formed steel with overlapping frame; finish same as door components; factory-installed.
 - 1. In Fire-Rated Doors: UL (DIR) or ITS (DIR) listed fusible link louver, same rating as door.
 - 2. Style: Sightproof inverted V blade.
 - 3. Security Louvers at exterior locations; Anemostat PLSL.
 - 4. Fasteners: Exposed, tamper proof fasteners oriented to secure side.
 - 5. Manufacturers:
 - a. Titus: Refer to Mechanical Drawings: www.titu_hvac.com.
 - b. Substitutions: See Section 01 6000 - Product Requirements.
- B. Glazing: As specified in Section 08 8000, factory installed.

- C. Removable Stops: Formed sheet steel, shape as indicated on drawings, mitered or butted corners; prepared for countersink style tamper proof screws.
- D. Silencers: Resilient rubber, fitted into drilled hole; provide three on strike side of single door, three on center mullion of pairs, and two on head of pairs without center mullions.
- E. Temporary Frame Spreaders: Provide for factory- or shop-assembled frames.

PART 3 EXECUTION

3.01 EXAMINATION

- A. Verify existing conditions before starting work.
- B. Verify that opening sizes and tolerances are acceptable.
- C. Verify that finished walls are in plane to ensure proper door alignment.

3.02 PREPARATION

3.03 INSTALLATION

- A. Install doors and frames in accordance with manufacturer's instructions and related requirements of specified door and frame standards or custom guidelines indicated.
- B. Fill all spaces between frame anchors and structure with approved shim material.
- C. Install fire rated units in accordance with NFPA 80.
- D. Coordinate frame anchor placement with wall construction.
- E. Install door hardware as specified in Section 08 7100.
- F. Comply with glazing installation requirements of Section 08 8000.

3.04 TOLERANCES

- A. Clearances Between Door and Frame: Comply with related requirements of specified frame standards or custom guidelines indicated in accordance with SDI 117 or NAAMM HMMA 861.
- B. Maximum Diagonal Distortion: 1/16 inch measured with straight edge, corner to corner.

3.05 ADJUSTING

- A. Adjust for smooth and balanced door movement.
- B. Protect completed work from damage. Replace damaged work.

3.06 SCHEDULE

- A. Refer to Door and Frame Schedule on the drawings.

END OF SECTION

**SECTION 08 3100
ACCESS DOORS AND PANELS**

PART 1 GENERAL

1.01 SECTION INCLUDES

- A. Wall and ceiling access door and frame units.
- B. Access door and frame units, fire-rated and non-fire-rated, in wall and ceiling locations wherever required for access to enclosed spaces or equipment.

1.02 RELATED REQUIREMENTS

- A. Section 01 6116 - Volatile Organic Compound (VOC) Content Restrictions.
- B. Section 09 9113 - Exterior Painting: Field paint finish.
- C. Section 09 9123 - Interior Painting: Field paint finish.
- D. Division 23 - Mechanical: Mechanical and plumbing components requiring access.
- E. Division 26 - Electrical: Electrical components requiring access.

1.03 REFERENCE STANDARDS

- A. California Code of Regulations, Title 24, Part 2, California Building Code (CBC), International Building Code.
- B. California Code of Regulations, Title 24, Part 11 California Green Building Standards Code, "CAL-Green".
- C. ITS (DIR) - Directory of Listed Products.
- D. Manufacturer's recommendations and specifications.
- E. UL (FRD) - Fire Resistance Directory.

1.04 DESIGN REQUIREMENTS

- A. Design Requirements: Provide door seals for access doors located in sound isolating walls or ceilings.
- B. Performance Requirements: Provide door covered access into all attic spaces and at all portions of the work to which access is necessary for periodic inspection, adjustments, or maintenance, and which is enclosed behind finish materials, including, but not limited to, valves, water hammer arrestors, mechanical units, electrical panels and outlets, equipment and systems.

1.05 SUBMITTALS

- A. See Section 01 3300 - Submittals, for submittal procedures.
- B. Schedule: Tabular listing of access doors and panels, indicating location, size, materials, fire rating, device or purpose for access.
- C. Product Data: Provide sizes, types, finishes, hardware, scheduled locations, and details of adjoining work.
- D. CAL-GREEN Submittals: Product Data - VOC Limits: For adhesives sealants, fillers, primers and coatings, documentation including printed statement of VOC contents, comply with limits specified in related section.
- E. Shop Drawings: Indicate exact position of each access door and/or panel unit.

- F. Manufacturer's Installation Instructions: Indicate installation requirements for fire rated units.
- G. Project Record Documents: Record actual locations of each access unit.

1.06 REGULATORY REQUIREMENTS

- A. Conform to Title 24, Part 2, California Building Code for fire rated access doors.
 - 1. Provide access doors of fire rating equivalent to the fire rated assembly in which they are to be installed.
- B. Provide products listed and labeled by UL or ITS (Warnock Hersey) as suitable for the purpose specified and indicated.

1.07 PROJECT CONDITIONS

- A. Coordinate the work with other work requiring access doors.

PART 2 PRODUCTS

2.01 PERFORMANCE REQUIREMENTS

- A. VOC Limits for adhesives, sealants, fillers, primers and coatings . Comply with limits specified in related section.

2.02 ACCESS DOORS AND PANELS ASSEMBLIES

- A. Wall-Mounted Units:
 - 1. Material: Steel.
 - 2. Door/Panel: Hinged, standard duty, with tool-operated spring or cam lock and no handle.
 - 3. Interior Locations: Tool-operated spring or cam lock; no handle.
 - 4. Exterior Locations: Key operated lock; no handle.
 - 5. Wall Mounting Criteria: Provide surface-mounted face frame and door surface flush with frame surface.
- B. Walls in Wet Areas, including Rest Rooms:
 - 1. Material: Stainless steel, Type 304.
 - 2. Door/Panel: Hinged, standard duty, with tool-operated spring or cam lock and no handle.
 - 3. Key operated lock; no handle.
 - 4. Wall Mounting Criteria: Provide surface-mounted face frame and door surface flush with frame surface.
- C. Fire-Rated Wall-Mounted Units:
 - 1. Wall Fire-Rating: As indicated on drawings.
 - 2. Material: Steel.
 - 3. Exterior Locations: Key operated lock; no handle.
 - 4. Interior Locations: Tool-operated spring or cam lock; no handle.
- D. Ceiling-Mounted Units:
 - 1. Material: Steel.
 - 2. Size - Lay-In Grid Ceilings: To match module of ceiling grid.
 - 3. Door/Panel: Hinged, standard duty, with tool-operated spring or cam lock and no handle.
 - 4. Exterior Locations: Key operated lock; no handle.
 - 5. Interior Locations: Tool-operated spring or cam lock; no handle.
- E. Fire-Rated Ceiling-Mounted Units:
 - 1. Ceiling Fire-Rating: As indicated on drawings.
 - 2. Material: Steel.
 - 3. Door/Panel: Hinged, standard duty, with tool-operated spring or cam lock and no handle.

- F. Interior Floor-Mounted Access Units:
 - 1. Location: As indicated on drawings.
 - 2. Size: 36 inch by 36 inch.

2.03 WALL AND CEILING MOUNTED UNITS

- A. Manufacturers:
 - 1. JL Industries, www.activarcpg.com/jl-industries.
 - 2. Karp Associates, Inc: www.karpinc.com.
 - 3. Milcor by Commercial Products Group of Hart & Cooley, Inc: www.milcorinc.com.
 - 4. Williams Brothers Corporation of America: www.wbdoors.com.
 - 5. Substitutions: See Section 01 6000 - Product Requirements.

2.04 ACCESS DOOR UNITS - WALLS AND CEILINGS

- A. Door sizes: Unless otherwise specifically noted on drawings; smallest standard size which will permit ready access and removal of working parts requiring maintenance.
- B. Door and Frame Units: Formed steel and stainless steel where noted.
 - 1. Door panels: 0.070 inch single thickness steel sheet.
 - 2. Units in Fire-Rated Assemblies: Fire rating as required by applicable code for fire-rated assembly that access doors are being installed.
 - a. Provide products listed by ITS (DIR) or UL (FRD) as suitable for purpose indicated.
 - 3. Hardware:
 - a. Hardware for Fire-Rated Units: As required for listing.
 - b. Hinges for Non-Fire-Rated Units: Concealed, constant force closure spring type.
 - c. Hinge: 175 degree stainless steel piano hinge with pin.
 - d. Interior Locations: Latch/Lock: Screw driver slot for quarter turn cam latch.
 - e. Exterior Locations and Rest Rooms: Latch/Lock: Cylinder lock operated cam latch, two keys for each unit.
 - 4. Galvanized, hot dipped finish at exterior or wet locations.

2.05 FABRICATION

- A. Weld, fill, and grind joints to ensure flush and square unit.

2.06 FINISHES

- A. General: Provide doors and/or panels of the following finishes as scheduled.
 - 1. Galvanized, hot dipped finish.
 - 2. Prime coat with alkyd primer.
 - 3. Stainless Steel Finish: No. 4 finish.

2.07 SOURCE QUALITY CONTROL

- A. Certifications: Furnish each fire rated door with affixed label of Underwriters Laboratories (UL), Warnock Hersey International (WHI), or other approved independent testing laboratory and inspection service, certifying scheduled fire rating.

PART 3 EXECUTION

3.01 EXAMINATION

- A. Investigate conditions requiring access, select panels of suitable type and configuration for conditions indicated.
- B. For conditions requiring access and for which panels or doors are not otherwise shown, recommend panel or door type and size for Architect's review.

- C. Verify that rough openings are correctly sized and located.

3.02 INSTALLATION

- A. Install units in accordance with manufacturer's instructions.
- B. Install frames plumb and level in openings, and secure units rigidly in place.
- C. Position units to provide convenient access to the concealed work requiring access. Avoid conflict with other building elements.

3.03 SCHEDULE

- A. Exterior Doors and Panels: Galvanized for site finishing specified in related section.
- B. Interior Doors and Panels in Restrooms, Food Preparation, Locker Rooms and in ceramic tile surfaced walls wherever located: Stainless steel construction, No. 4 finish.
- C. Interior Doors and Panels in all other locations: Primed for site finishing specified in related section.

END OF SECTION

SECTION 08 3323
OVERHEAD COILING DOORS

PART 1 GENERAL

1.01 SECTION INCLUDES

- A. Overhead coiling doors, operating hardware, non-fire-rated, electric operation.
- B. Wiring from electric circuit disconnect to operator to control station.

1.02 RELATED REQUIREMENTS

- A. Section 01 1113 Hollow Metal Doors And Frames
- B. Section 08 7100 - DOOR HARDWARE: Cylinder cores and keys.
- C. Section 09 9123 - Interior Painting: Field paint finish.
- D. Section 26 0583 - Wiring Connections: Power to disconnect.

1.03 REFERENCE STANDARDS

- A. ASTM A36/A36M - Standard Specification for Carbon Structural Steel.
- B. ASTM A123/A123M - Standard Specification for Zinc (Hot-Dip Galvanized) Coatings on Iron and Steel Products.
- C. ASTM A653/A653M - Standard Specification for Steel Sheet, Zinc-Coated (Galvanized) or Zinc-Iron Alloy-Coated (Galvannealed) by the Hot-Dip Process.
- D. ASTM A666 - Standard Specification for Annealed or Cold-Worked Austenitic Stainless Steel Sheet, Strip, Plate, and Flat Bar.
- E. NEMA 250 - Enclosures for Electrical Equipment (1000 Volts Maximum).
- F. NEMA ICS 2 - Industrial Control and Systems Controllers, Contactors and Overload Relays Rated 600 Volts.
- G. NEMA MG 1 - Motors and Generators.

1.04 SUBMITTALS

- A. See Section 01 3300 - Submittals, for submittal procedures.
- B. Demonstrate compliance with specified attributes.
- C. Product Data: Provide general construction, electrical equipment, and component connections and details.
- D. Shop Drawings: Indicate pertinent dimensioning, anchorage methods, hardware locations, and installation details.
- E. Manufacturer's Installation Instructions: Indicate installation sequence and procedures, adjustment and alignment procedures.
- F. Maintenance Data: Indicate lubrication requirements and frequency and periodic adjustments required.

PART 2 PRODUCTS

2.01 MANUFACTURERS

- A. Overhead Coiling Doors:
 - 1. The Cookson Company: www.cooksondoor.com/#sle.
 - 2. Overhead Door Corporation: www.overhaddoor.com
 - 3. Substitutions: See Section 01 6000 - Product Requirements.

2.02 COILING DOORS

- A. Non-Fire-Rated Interior Coiling Doors: Steel slat curtain.
 - 1. Single thickness slats.
 - 2. Nominal Slat Size: 2 inches wide x required length.
 - 3. Finish: Anodized, clear color.
 - 4. Guides, Angles: Galvanized steel.
 - 5. Hood Enclosure: Manufacturer's standard; primed steel.
 - 6. Electric operation.
 - 7. Mounting: Surface mounted.
- B. Non-Fire-Rated Interior Coiling Counter Doors: Stainless steel slat curtain. Cookson CDF- K.
 - 1. Single thickness 22 gauge slats.
 - 2. Tubular stainless steel bottom bar with resilient astragal.
 - 3. Nominal Slat Size: 1-1/4 inches wide x required length.
 - 4. Finish: No. 4.
 - 5. Guides: Angles; stainless steel.
 - 6. Hood Enclosure: Stainless Steel.
 - 7. Hood Enclosure: Manufacturer's standard; primed steel.
 - 8. Electric operation with key operated controls and safety edge bottom bar.
 - 9. Mounting: Surface mounted.

2.03 MATERIALS

- A. Curtain Construction: Interlocking slats.
 - 1. Slat Ends: Alternate slats fitted with end locks to act as wearing surface in guides and to prevent lateral movement.
 - 2. Curtain Bottom: Fitted with angles to provide reinforcement and positive contact in closed position.
- B. Steel Slats: Minimum thickness, 22 gage, 2 inch; ASTM A653/A653M galvanized steel sheet.
- C. Stainless Steel Slats: Minimum thickness, 22 gage, 1 1/4 inch, conforming to ASTM A 666, Type 304, rollable temper.
- D. Guide Construction: Continuous, of profile to retain door in place with snap-on trim, mounting brackets of same metal.
- E. Guides - Angle: ASTM A36/A36M metal angles, size as indicated.
 - 1. Hot-dip galvanized in compliance with ASTM A123/A123M.
- F. Stainless Steel: ASTM A 666, Type 304, rollable temper.
- G. Hood Enclosure: Internally reinforced to maintain rigidity and shape.
 - 1. Prime paint.
- H. Lock Hardware:
 - 1. Cylindrical Locking Mechanism: Latchset lock cylinder, specified in Section 08 7100.
 - 2. For motor operated units, additional lock or latching mechanisms are not required.

- I. Roller Shaft Counterbalance: Steel pipe and helical steel spring system, capable of producing torque sufficient to ensure smooth operation of curtain from any position and capable of holding position at mid-travel; with adjustable spring tension; requiring 25 lb nominal force to operate.

2.04 ELECTRIC OPERATION

- A. Electric Operators:
 1. Mounting: Side mounted.
 2. Motor Enclosure:
 - a. Interior Doors: NEMA MG 1, Type 1; open drip proof.
 3. Motor Rating: 1/3 hp; continuous duty.
 4. Motor Controller: NEMA ICS 2, full voltage, reversing magnetic motor starter.
 5. Controller Enclosure: NEMA 250, Type 1.
 6. Opening Speed: 12 inches per second.
 7. Brake: Adjustable friction clutch type, activated by motor controller.
 8. Manual override in case of power failure.
- B. Control Station: Standard three button (OPEN-STOP-CLOSE) momentary control for each operator.
 1. 24 volt circuit.
- C. Safety Edge: Located at bottom of curtain, full width, electro-mechanical sensitized type, wired to stop operator upon striking object, hollow neoprene covered.

PART 3 EXECUTION

3.01 EXAMINATION

- A. Verify that opening sizes, tolerances and conditions are acceptable.

3.02 INSTALLATION

- A. Install units in accordance with manufacturer's instructions.
- B. Use anchorage devices to securely fasten assembly to wall construction and building framing without distortion or stress.
- C. Securely and rigidly brace components suspended from structure. Secure guides to structural members only.
- D. Fit and align assembly including hardware; level and plumb, to provide smooth operation.
- E. Coordinate installation of electrical service with Section 26 0583.
- F. Complete wiring from disconnect to unit components.

3.03 TOLERANCES

- A. Maintain dimensional tolerances and alignment with adjacent work.
- B. Maximum Variation From Plumb: 1/16 inch.
- C. Maximum Variation From Level: 1/16 inch.
- D. Longitudinal or Diagonal Warp: Plus or minus 1/8 inch per 10 ft straight edge.

3.04 ADJUSTING

- A. Adjust operating assemblies for smooth and noiseless operation.

3.05 CLEANING

- A. Clean installed components.

- B. Remove labels and visible markings.

END OF SECTION

SECTION 08 4313

ALUMINUM ENTRANCES AND STOREFRONTS

PART 1 GENERAL

1.01 SECTION INCLUDES

- A. Aluminum-framed storefront, with vision glass.
- B. Infill panels of glass.
- C. Sliding Service windows inserts.
- D. Transaction windows inserts.
- E. Perimeter sealant.
- F. Section also includes Contractor's responsibility to assume role of "Responsible Party" for NFRC label testing and inspection "Certified Project Option", to obtain Fenestration Acceptance Requirements certification required for occupancy permit. Refer to California Energy Code Section 110.6.
- G. Deferred Approval: Delegated Design by Contractor's Engineer for deferred approval by Division of State Architect.

1.02 RELATED REQUIREMENTS

- A. Section 01 6116 - Volatile Organic Compound (VOC) Restrictions.
- B. Section 07 2500 - WEATHER BARRIERS: Sealing framing to weather barrier installed on adjacent construction.
- C. Section 07 9200 - Joint Sealants: Sealing joints between frames and adjacent construction.
- D. Section 08 5600 - Special Windows
- E. Section 08 8000 - Glazing: Glass and glazing accessories.

1.03 REFERENCE STANDARDS

- A. 36 CFR 1191 - Americans with Disabilities Act Accessibility Guidelines for Buildings and Facilities; Final Rule; Federal Register, July 26, 1991; updated 2010.
- B. AAMA CW-10 - Care and Handling of Architectural Aluminum From Shop to Site.
- C. AAMA 501.2 - Field Check of Metal Storefronts, Curtain Walls, and Sloped Glazing Systems for Water Leakage.
- D. AAMA 503 - Voluntary Specification for Field Testing of Newly Installed Storefronts, Curtain Walls and Sloped Glazing Systems.
- E. AAMA 611 - Voluntary Specification for Anodized Architectural Aluminum.
- F. AAMA 1503 - Voluntary Test Method for Thermal Transmittance and Condensation Resistance of Windows, Doors and Glazed Wall Sections.
- G. AAMA 2605 - Voluntary Specification, Performance Requirements and Test Procedures for Superior Performing Organic Coatings on Aluminum Extrusions and Panels.
- H. ASCE 7 - Minimum Design Loads for Buildings and Other Structures.
- I. ASTM A36/A36M - Standard Specification for Carbon Structural Steel.

- J. ASTM A123/A123M - Standard Specification for Zinc (Hot-Dip Galvanized) Coatings on Iron and Steel Products.
- K. ASTM B209 - Standard Specification for Aluminum and Aluminum-Alloy Sheet and Plate.
- L. ASTM B221 - Standard Specification for Aluminum and Aluminum-Alloy Extruded Bars, Rods, Wire, Profiles, and Tubes.
- M. ASTM B221M - Standard Specification for Aluminum and Aluminum-Alloy Extruded Bars, Rods, Wire, Profiles, and Tubes [Metric].
- N. ASTM E283 - Standard Test Method for Determining the Rate of Air Leakage Through Exterior Windows, Curtain Walls, and Doors Under Specified Pressure Differences Across the Specimen.
- O. ASTM E330/E330M - Standard Test Method for Structural Performance of Exterior Windows, Doors, Skylights and Curtain Walls by Uniform Static Air Pressure Difference.
- P. ASTM E331 - Standard Test Method for Water Penetration of Exterior Windows, Skylights, Doors, and Curtain Walls by Uniform Static Air Pressure Difference.
- Q. California Code of Regulations, Title 24, Part 11 California Green Building Standards Code, "CAL-Green", current edition.
- R. California Energy Code "Building Energy Efficiency Standards", 2016.
- S. California Energy Code "Reference Nonresidential Appendix NA7", 2016.
- T. California Code of Regulations, Title 24, Part 2, California Building Code (CBC), International Building Code, with California Amendments, current edition.
- U. SSPC-Paint 20 - Zinc-Rich Primers (Type I, "Inorganic," and Type II, "Organic").
- V. SSPC-Paint 25 - Zinc Oxide, Alkyd, Linseed Oil Primer for Use Over Hand Cleaned Steel, Type I and Type II; Society for Protective Coatings.

1.04 ADMINISTRATIVE REQUIREMENTS

- A. Coordinate with installation of other components that comprise the exterior enclosure.
- B. Preinstallation Meeting: Conduct a preinstallation meeting two weeks before starting work of this section; require attendance by all affected installers.
 - 1. Meet at Project site with Installer, installer of each component of associated work, installers of substrate construction to receive this work, installers of other work that must precede or follow storefront work (including mechanical work if any), Architect/Owner, storefront system manufacturer's representative, and other representatives directly concerned with performance of the Work, including (where applicable) Owner's insurers, test agencies, and governing authorities. Objectives to include:
 - a. Review preparation and installation procedures and coordinating and scheduling required with related work.
 - b. Review methods and procedures related to storefront and glazing work.
 - c. Review structural loading limitations of new storefront.
 - d. Review storefront systems requirements (drawings, specifications, and other contract documents).
 - e. Review required submittals, both completed and yet to be completed, including deferred approvals, if any.
 - f. Review and finalize construction schedule related to storefront work and verify availability of materials, Installer's personnel, equipment, and facilities needed to make progress and avoid delays.

- g. Review required inspection, testing, certifying, and material usage accounting procedures.
- h. Review weather and forecasted weather conditions and procedures for coping with unfavorable conditions, including provision of temporary enclosure of partially completed or occupied spaces.
- i. Record discussion of conference, including decisions and agreements (or disagreements) reached, and furnish copy of record to each party attending. If substantial disagreements exist at conclusion of conference, determine how disagreements will be resolved and set date for reconvening conference.
- j. Review notification procedures for weather or non-working days.

1.05 SUBMITTALS

- A. See Section 01 3300 - Submittals, for submittal procedures.
- B. Provide submittals coordinated with submittals for related sections referenced in this Section for simultaneous review.
- C. Division of the State Architect Deferred Approval Submittal Requirements:
 - 1. This section specifies work that is a Division of the State Architect (DSA) deferred approval item. All Engineering calculations and Shop Drawings require review and approval by the Division of the State Architect prior to fabrication or installation. Deferred Approval review provisions of Section 01 3300 apply to the submittals of this section.
 - 2. Submit items for deferred approval complete with all structural calculations, test data and information as specified or as subsequently required by the reviewing agency, including engineering stamps and signatures as required. Architect shall submit to DSA only following Architect/Engineer review.
 - a. The Architect will not approve deferred approval submittals until they are approved by DSA.
 - 3. No work or fabrication shall begin until DSA approved submittals are distributed to the Contractor.
 - 4. Contractor is notified that significant lead time is required for deferred approval review by DSA and shall schedule submittals accordingly. No extension of Contract Time will be allowed for delays incurred by deferred approval review.
 - a. The Architect is not responsible for DSA delays in deferred approval review.
 - 5. Submit Certification of Compliance and all other documentation as required by Division of the State Architect.
 - 6. Make all changes and revisions required by Division of State Architect to obtain approval at no additional costs or extension of time.
- D. Product Data: Provide component dimensions, describe components within assembly, anchorage and fasteners, glass and infill, internal drainage details and perimeter conditions.
- E. VOC Submittals:
 - 1. Product Data - VOC Limits: For adhesives sealants, fillers and primers, documentation including printed statement of VOC contents, demonstrate compliance with limits specified in Section 01 6116.
- F. Shop Drawings: Indicate system dimensions, framed opening requirements and tolerances, affected related Work, expansion and contraction joint location and details, and field welding required.
 - 1. Shop drawings shall include project-specific integrations to surrounding cladding and waterproofing components, including items specified in other sections.
 - 2. Provide installation instructions and isometric details indicating how system components will be installed and sealed watertight.
- G. Design Data: Provide framing member structural and physical characteristics, engineering calculations, and dimensional limitations.

- H. Deferred Approval - Structural Calculations: Substantiating system performance, structural capacity, anchorages and fasteners sizes and spacings per specified criteria, stamped and signed by Professional Structural Engineer experienced in design of this Work and licensed in California. Provide minimum of two copies with original stamps and signature.
- I. Samples: Submit two samples 12x12 inches in size illustrating finished aluminum surface, glass, glazing materials.
- J. Manufacturer's Certificate: Certify that the products supplied meet or exceed the specified requirements.
- K. Report of field testing for water leakage.
- L. Warranty: Submit manufacturer warranty and ensure forms have been completed in Owner's name and registered with manufacturer.

1.06 INFORMATIONAL SUBMITTALS

- A. Delegated-Design Submittal: For aluminum-framed systems indicated to comply with performance requirements and design criteria, substantiating system performance, structural capacity, anchorages and fasteners sizes and spacings per specified criteria, including analysis data signed and sealed by the qualified professional engineer responsible for their preparation.
 - 1. Detail fabrication and assembly of aluminum-framed systems.
 - 2. Include design calculations.
 - 3. Assume role of "Responsible Party" for NFRC label testing and inspection "Certified Project Option". Make all arrangements necessary to perform required testing of site-built assembly and obtain NFRC label as described in NFRC 100.5.6.
- B. Qualification Data: For qualified Installer and testing agency.
- C. Professional Engineer Qualifications: Demonstrate compliance with specified requirements.
- D. Certificate of Acceptance: Refer to California Energy Code Section 110.6.
 - 1. Submit Certificate of Acceptance certifying that the fenestration product meets the required acceptance requirements, completed, signed and submitted to the enforcement agency, with copies to Owner and Architect.
- E. Seismic Qualification Certificates: For aluminum-framed systems, accessories, and components, from manufacturer.
 - 1. Basis for Certification: Indicate whether withstand certification is based on actual test of assembled components or on calculation.
- F. Welding certificates.
- G. Preconstruction Test Reports: For sealant.
- H. Product Test Reports: Based on evaluation of comprehensive tests performed by a qualified testing agency, for aluminum-framed systems, indicating compliance with performance requirements. For each system provide test reports with shop drawings
- I. Source quality-control reports.
 - 1. Field quality-control reports.
- J. NFRC 100 Label Certificate: Submit proof of testing of site-built assembly and compliance with NFRC 100. Manufacturer certificates or factory tests are not acceptable for this requirement.
- K. Warranties: Sample of special warranties.

1.07 QUALITY ASSURANCE

- A. Deferred Approval - Delegated Design: Design structural support framing components and anchorages under direct supervision of a Professional Structural Engineer experienced in design of this Work and licensed at California.
- B. Manufacturer Qualifications: Company specializing in performing work of type specified and with at least three years of documented experience.
- C. Professional Engineer Qualifications: A professional engineer who is legally qualified to practice in jurisdiction where Project is located and who is experienced in providing engineering services of the kind indicated. Engineering services are defined as those performed for installations of assemblies that are similar to those indicated for this Project in material, design, and extent.
- D. Engineering Responsibility: Prepare data for aluminum-framed systems, including Shop Drawings, based on testing and engineering analysis of manufacturer's standard units in systems similar to those indicated for this Project.
- E. NFRC Compliance: Completed site-built assembly shall conform to NFRC 100 requirements and be tested and labeled in accordance with that standard.
- F. Testing Agency Qualifications: Qualified according to ASTM E 699 for testing indicated.
- G. Product Options: Information on Drawings and in Specifications establishes requirements for systems' aesthetic effects and performance characteristics. Aesthetic effects are indicated by dimensions, arrangements, alignment, and profiles of components and assemblies as they relate to sightlines, to one another, and to adjoining construction. Performance characteristics are indicated by criteria subject to verification by one or more methods including preconstruction testing, field testing, and in-service performance.
 - 1. Do not revise intended aesthetic effects, as judged solely by Architect, except with Architect's approval. If revisions are proposed, submit comprehensive explanatory data to Architect for review.

1.08 DELIVERY, STORAGE, AND HANDLING

- A. Handle products of this section in accordance with AAMA CW-10.
- B. Protect finished aluminum surfaces with wrapping. Do not use adhesive papers or sprayed coatings that bond to aluminum when exposed to sunlight or weather.

1.09 FIELD CONDITIONS

- A. Field Measurements: Verify actual locations of structural supports for aluminum-framed systems by field measurements before fabrication and indicate measurements on Shop Drawings.
- B. Established Dimensions: Where field measurements cannot be made without delaying the Work, establish dimensions and proceed with fabricating glazed aluminum curtain-wall systems correspond to established dimensions.
- C. Do not install sealants when ambient temperature is less than 40 degrees F. Maintain this minimum temperature during and 48 hours after installation.

1.10 WARRANTY

- A. See General Conditions, Article 3 The Contractor, for additional warranty requirements.
- B. Special Warranty: Manufacturer's standard form in which manufacturer agrees to repair or replace components of aluminum-framed systems that do not comply with requirements or that fail in materials or workmanship within specified warranty period.

1. Failures include, but are not limited to, the following:
 - a. Structural failures including, but not limited to, excessive deflection.
 - b. Noise or vibration caused by thermal movements.
 - c. Deterioration of metals and other materials beyond normal weathering.
 - d. Adhesive or cohesive sealant failures.
 - e. Water leakage through fixed glazing and framing areas.
 - f. Failure of operating components.
- C. Correct defective Work within a five year period after Date of Substantial Completion.
- D. Provide ten year manufacturer warranty against excessive degradation of exterior finish. Include provision for replacement of units with excessive fading, chalking, or flaking.

PART 2 PRODUCTS

2.01 DESIGN REQUIREMENTS

- A. Delegated Design: Design aluminum-framed systems, including comprehensive engineering analysis by a qualified professional engineer, using performance requirements and design criteria indicated.
- B. VOC Limits for adhesives sealants, fillers, coatings and primers. Comply with limits specified in Section 01 6116.
- C. Assume role of "Responsible Party" for NFRC label testing and inspection "Certified Project Option". Make all arrangements necessary to perform required testing of site-built assembly and obtain NFRC label as described in NFRC 100.5.6. Contractor is responsible to obtain, including payment of all required fees, a label certificate for the site built fenestration system meeting requirements of California Energy Code 2016 Section 10-111(a)2 as described in California Energy Code Section 110.6.
- D. Thermally Broken: All components, including doors, to be thermally broken with continuous resilient elastomeric extrusions.
- E. Weather Resistance:
 1. Design shall provide waterproofing and an air-vapor retarder that is continuous at all penetrations, transitions, and other conditions. System shall integrate with the building's waterproofing and air-vapor-retarder system to provide a weathertight transition. System shall not allow the movement of the interior or exterior air to flow vertically within the assembly. Methods employed to prevent internal air movement shall not restrict water flow channels or prevent thermal movement of the frames.
 2. Water penetration into the system is acceptable only if all of the following conditions are satisfied; any other water penetration is considered water leakage and is unacceptable:
 - a. Water is immediately contained and drained to the exterior.
 - b. There is no wetting of a surface that could be damaged by moisture or that would be visible to building occupants.
 - c. There would be no staining or other damage to completed building or its furnishings.
 - d. This definition of water leakage governs over the other definitions that may appear in referenced documents.
 3. Provide internal gutters and weep systems to collect and drain water leakage and condensation to the exterior at the sill of each opening. Glazing assemblies shall have an isolated gutter cavity at each glass perimeter so the leakage is confined to and wept from the opening of origin. Glazing assemblies shall have continuous spliced gutters at mullions splices, with sealed and caps at termination conditions. Systems shall not direct water to contact edges of insulating glass units. Prevent water infiltration at weeps. Coordinate gutter and weep systems with other sections.

2.02 MANUFACTURERS

- A. Aluminum-Framed Storefront and Doors:
 - 1. Oldcastle Building Envelope; Basis of Design: FG-3000: www.oldcastlebe.com.
 - 2. EFCO Corporation: www.efcocorp.com.
 - 3. Kawneer North America: www.kawneer.com.
- B. Substitutions: See Section 01 6000 - Product Requirements.

2.03 STOREFRONT

- A. Aluminum-Framed Storefront: Factory fabricated, factory finished aluminum framing members with infill, and related flashings, anchorage and attachment devices.
 - 1. Glazing Position: Centered (front to back).
 - 2. Water Leakage Test Pressure Differential: 10 lbf/sq ft.
 - 3. Air Infiltration Test Pressure Differential: 6.24 psf.
 - 4. Finish: Class II natural anodized.
 - a. Factory finish all surfaces that will be exposed in completed assemblies.
 - 5. Fabrication: Joints and corners flush, hairline, and weatherproof, accurately fitted and secured; prepared to receive anchors and hardware; fasteners and attachments concealed from view; reinforced as required for imposed loads.
 - 6. Construction: Eliminate noises caused by wind and thermal movement, prevent vibration harmonics, and prevent "stack effect" in internal spaces.
 - 7. System Internal Drainage: Drain to the exterior by means of a weep drainage network any water entering joints, condensation occurring in glazing channel, and migrating moisture occurring within system.
 - 8. Expansion/Contraction: Provide for expansion and contraction within system components caused by cycling temperature range of 170 degrees F over a 12 hour period without causing detrimental effect to system components, anchorages, and other building elements.
 - 9. Movement: Allow for movement between storefront and adjacent construction, without damage to components or deterioration of seals.
 - 10. Perimeter Clearance: Minimize space between framing members and adjacent construction while allowing expected movement.
 - 11. Air and Vapor Seal: Maintain continuous air barrier and vapor retarder throughout assembly, primarily in line with inside pane of glazing and inner sheet of infill panel and heel bead of glazing compound.
- B. Performance Requirements:
 - 1. Structural Loads:
 - a. Wind Loads: As indicated on the Drawings.
 - b. Seismic Loads: As indicated on the Drawings.
 - c. Other Design Loads: As indicated on Drawings.
 - 2. Wind Loads: Design and size components to withstand the specified load requirements without damage or permanent set, when tested in accordance with ASTM E330/E330M, using loads 1.5 times the design wind loads and 10 second duration of maximum load.
 - a. Member Deflection: Limit member deflection to flexure limit of glass in any direction, with full recovery of glazing materials.
 - 3. Water Penetration Resistance: No uncontrolled water as described in paragraph "Weather Resistance" above, when tested in accordance with ASTM E331 at pressure differential of 12 lbf/sq ft.
 - 4. Air Leakage: Maximum of 0.06 cu ft/min sq ft of wall area, when tested in accordance with ASTM E283 at 6.27 psf pressure differential across assembly.
 - 5. Thermally Broken: All components, including doors, to be thermally broken with continuous resilient elastomeric extrusions.

6. Condensation Resistance Factor of Framing: 50, minimum, measured in accordance with AAMA 1503.
7. Air Infiltration: Limit air infiltration through assembly to 0.06 cu ft/min/sq ft of wall area, measured at specified differential pressure across assembly in accordance with ASTM E283.
8. Failure defined to include any of the following:
 - a. Deflection exceeding specified limits.
 - b. Water penetration, including condensation, in excess of that specified in this section.
 - c. Thermal stresses transferring to building structure.
 - d. Framing members transferring stresses, including those caused by thermal and structural movements to glazing.
 - e. Noise or vibration created by wind and by thermal and structural movements.
 - f. Loosening or weakening of fasteners, attachments, and other components.
 - g. Sealant failure.
 - h. Failure of operating units.

2.04 COMPONENTS

- A. Aluminum Framing Members: Tubular aluminum sections, drainage holes and internal weep drainage system.
 1. Glazing Stops: Flush.
 2. Cross-Section: 2 by 4-1/2 inch nominal dimension.
- B. Sliding Service Windows: As specified in Section 08 5600 Special Windows.
- C. Transaction Windows: As specified in Section 08 5600 Special Windows.

2.05 GLAZING

- A. Glazing: As specified in Division 08 Section "Glazing."
- B. Glazing Gaskets: Manufacturer's standard compression types; replaceable, molded or extruded, of profile and hardness required to maintain watertight seal.
- C. Spacers and Setting Blocks: Manufacturer's standard elastomeric type.
- D. Bond-Breaker Tape: Manufacturer's standard TFE-fluorocarbon or polyethylene material to which sealants will not develop adhesion.

2.06 MATERIALS

- A. Extruded Aluminum: ASTM B221 (ASTM B221M). 6063 alloy, T5 temper.
- B. Fasteners: Stainless steel.
- C. Exposed Flashings: Aluminum sheet, 20 gage, 0.032 inch minimum thickness; finish to match framing members.
 1. Break shapes as indicated, as recommended by manufacturer, and as required to fully enclosed and seal system.
- D. Sill Flashing Sealant: Elastomeric, silicone or polyurethane, compatible with flashing material.
- E. Sealant for Setting Thresholds: Non-curing butyl type.
- F. Concealed Flashings: 0.018 inch thick stainless steel, dead soft, as selected by manufacturer for compatibility with other components.
- G. Perimeter Sealant: Silicone, as specified in Section 07 9200

- H. Glazing Gaskets: Type to suit application to achieve weather, moisture, and air infiltration requirements.
- I. Glazing Accessories: As specified in Section 08 8000.
- J. Shop and Touch-Up Primer for Steel Components: SSPC-Paint 25, zinc oxide, alkyd, linseed oil primer.
- K. Touch-Up Primer for Galvanized Steel Surfaces: SSPC-Paint 20, zinc rich.
- L. Protective Backing Paint: Bituminous type, emulsified asphalt, ASTM D1187.

2.07 FINISHES

- A. Superior Performing Organic Coatings: AAMA 2605 multiple coat, thermally cured polyvinylidene fluoride (PVDF) system.
- B. Color: As selected by Architect from manufacturer's standard range.
- C. Touch-Up Materials: As recommended by coating manufacturer for field application.

2.08 FABRICATION

- A. General: Fabricate aluminum entrance and storefront components to designs, sizes and thickness indicated, and to comply with specified standards. Sizes and profile requirements are indicated on the drawings.
- B. Prefabrication: Complete fabrication, assembly, finishing, hardware application, and other work before shipment to Project site. Disassemble components only where necessary for shipment and installation.
 - 1. Perform fabrication operations, including cutting, fitting, forming, drilling and grinding of metal work to prevent damage to exposed finish surfaces. Complete these operations for hardware prior to application of finishes.
 - 2. Do not drill and tap for surface-mounted hardware items until time of installation at Project site.
- C. Framing Members, General: Fabricate components that, when assembled, have the following characteristics:
 - 1. Profiles that are sharp, straight, and free of defects or deformations.
 - 2. Accurately fitted joints with ends coped or mitered.
 - 3. Means to drain water passing joints, condensation within framing members, and moisture migrating within the system to exterior.
 - 4. Physical and thermal isolation of glazing from framing members.
 - 5. Accommodations for thermal and mechanical movements of glazing and framing to maintain required glazing edge clearances.
 - 6. Provisions for field replacement of glazing from interior for vision glass and exterior for spandrel glazing or metal panels.
 - 7. Fasteners, anchors, and connection devices that are concealed from view to greatest extent possible.
- D. Continuity: Maintain accurate relation of planes and angles with hairline fit of contacting members. Fabricate curved members to true shapes as shown on drawings, segmented or faceted curves are not acceptable. Fabricate components with minimum clearances and shim spacing around perimeter of assembly, while enabling installation and dynamic movement of perimeter seal.
- E. Accurately fit and secure joints and corners. Make joints flush, hairline, and weatherproof.
- F. Prepare components to receive anchor devices. Fabricate anchors.

- G. Welding: Comply with AWS recommendations. Grind exposed welds smooth to remove weld spatter and welding oxides. Restore mechanical finish.
 - 1. Welding behind finished surfaces shall be performed to minimize distortion and discoloration on the finished surface.
- H. Reinforcing: Install reinforcing as required for hardware, performance requirements, sag resistance and rigidity.
- I. Dissimilar Metals: Separate dissimilar metals and concealed metal surfaces that will be in contact with cementitious materials with bituminous paint, suitable sealant, elastomeric tape, or gasket between the surfaces. Do not use coatings containing lead.
- J. Reinforce components internally for door hardware and door operators.
- K. Reinforce framing members for imposed loads.
- L. Finishing: Apply factory finish to all surfaces that will be exposed in completed assemblies.
 - 1. Touch-up surfaces cut during fabrication so that no natural aluminum is visible in completed assemblies, including joint edges.
- M. After fabrication, clearly mark components to identify their locations in Project according to Shop Drawings.

PART 3 EXECUTION

3.01 EXAMINATION

- A. Verify, with installer present, dimensions, tolerances, and method of attachment with other work.
- B. Verify that wall openings and adjoining air and vapor seal materials are ready to receive work of this section.
- C. Proceed with installation only after unsatisfactory conditions have been corrected.

3.02 INSTALLATION

- A. Install wall system in accordance with manufacturer's instructions.
 - 1. Do not install damaged components.
- B. Attach to structure to permit sufficient adjustment to accommodate construction tolerances and other irregularities.
- C. Provide alignment attachments and shims to permanently fasten system to building structure.
- D. Align assembly plumb and level, free of warp or twist. Maintain assembly dimensional tolerances, aligning with adjacent work.
- E. Provide thermal isolation where components penetrate or disrupt building insulation.
- F. Install sill and perimeter flashings. Turn up ends and edges; seal to adjacent work to form water tight dam.
- G. Install components to drain water passing joints, condensation occurring within framing members, and moisture migrating within the system to exterior.
- H. Where fasteners penetrate sill flashings, make watertight by seating and sealing fastener heads to sill flashing.
- I. Coordinate attachment and seal of perimeter air and vapor barrier materials.

- J. Pack fibrous insulation in shim spaces at perimeter of assembly to maintain continuity of thermal barrier.
- K. Install glass in accordance with Section 08 8000, using glazing method required to achieve performance criteria.
- L. Install perimeter sealant in accordance with Section 07 9200.
- M. Touch-up minor damage to factory applied finish; replace components that cannot be satisfactorily repaired.

3.03 TOLERANCES

- A. Maximum Variation from Plumb: 0.06 inches every 3 ft non-cumulative or 1/16 inches per 10 ft, whichever is less.
- B. Maximum Misalignment of Two Adjoining Members Abutting in Plane: 1/32 inch.

3.04 FIELD QUALITY CONTROL

- A. See Section 01 4000 - Quality Requirements, for independent testing and inspection requirements. Inspection will monitor quality of installation and glazing.
- B. Test installed storefront for water leakage in accordance with AAMA 501.2 hose test.
- C. Provide field testing of installed storefront system by independent laboratory in accordance with AAMA 503 during construction process and before installation of interior finishes.
 - 1. Perform a minimum of two tests in each designated area as indicated on drawings.
 - 2. Conduct tests in each area prior to 10 percent and 50 percent completion of this work.
 - 3. Field test for water penetration in accordance with ASTM E1105 with uniform static air pressure difference (Procedure A) not less than 4.18 psf.
 - a. Maximum allowable rate of water penetration in 15-minute test is 0.5 ounce that is not contained in an area with provisions to drain to exterior, or collected on surface of interior horizontal framing member.
- D. Repair or replace storefront components that have failed designated field testing, and retest to verify performance conforms to specified requirements.
- E. Repair or remove work if test results and inspections indicate that it does not comply with specified requirements.
- F. Additional testing and inspecting, at Contractor's expense, will be performed to determine compliance of replaced or additional work with specified requirements.
- G. Aluminum-framed assemblies will be considered defective if they do not pass tests and inspections. Should failure occur, Contractor shall test one additional are for each failed location
- H. Prepare test and inspection reports.
- I. Fenestration Acceptance Requirements: Refer to California Energy Code Section 110.6.
 - 1. Before an occupancy permit is granted, site-built fenestration products in other than low-rise residential buildings shall be certified as meeting the Acceptance Requirements for Code Compliance, as specified in the Reference Nonresidential Appendix NA7 to ensure that site-built fenestration meet Standards requirements, including a matching label certificate for product(s) installed and be readily accessible at the project location.
 - 2. Contractor is responsible to prepare and obtain a Certificate of Acceptance certifying that the fenestration product meets the acceptance requirements, completed, signed and submitted to the enforcement agency, including payment of all fees, with copies to Owner and Architect.

3.05 CLEANING

- A. Remove protective material from pre-finished aluminum surfaces.
- B. Remove excess sealant by method acceptable to sealant manufacturer.

3.06 PROTECTION

- A. Protect installed products from damage until Date of Substantial Completion.
- B. Touch-up minor damage to factory applied finish, no exposed unfinished aluminum allowed in finish work; replace components that cannot be satisfactorily repaired.

END OF SECTION

SECTION 08 5600
SPECIAL WINDOWS

PART 1 GENERAL

1.01 SECTION INCLUDES

- A. Sliding Service Windows.
- B. Transaction Windows.

1.02 RELATED SECTIONS

- A. Section 06 1000- Rough Carpentry: Opening Framing.
- B. Section 06 4100 - Custom Cabinets.
- C. Section 08 4313 - Aluminum Entrances and Storefronts.
- D. Section 11 4000- Food Service Equipment: Stainless steel countertops.

1.03 REFERENCES

- A. UL 752 - Standard for Bullet-Resisting Equipment, Underwriters Laboratories Inc., March 2000.

1.04 PERFORMANCE REQUIREMENTS

- A. Conform to UL Standard 752 for Bullet-Resistant Glazing Materials Level specified.

1.05 SUBMITTALS

- A. See Section 01 3300 - Submittals for submittal procedures.
- B. Product Data: Provide manufacturer's product data and installation instructions.
- C. Shop Drawings: Indicate opening dimensions, elevations of types, anchorage size and location, installation requirements.
- D. Certificates: Certify that products of this section meet or exceed specified requirements.
- E. Warranty: Submit manufacturer warranty and ensure that forms have been completed in Owner 's name and registered with manufacturer.

1.06 DELIVERY, STORAGE, AND PROTECTION

- A. Deliver products and materials to project site in original containers and packaging.
- B. Comply with pertinent provisions of Section 01 6000.

PART 2 PRODUCTS

2.01 MANUFACTURED UNITS

- A. Sliding Service Window. Vertical sliding window with sliding screen.
 - 1. Nylon runners over coiled compression springs. Window and screen hold in placed position.
 - 2. Frames and glass channels: 6063-T5 aluminum.
 - 3. Lock: Interior slide type, manufacturer's standard.
 - 4. Glass: 1/4 inch clear tempered, factory glazed.
 - 5. Frame surround: manufacturer's standard.
 - 6. Screen: gray fiberglass, insect resistant.
 - 7. Counter seal: wool pile.
 - 8. Finish: as selected from manufacturer's standards.
 - 9. Manufacturers:

- a. Nissen Co., South El Monte CA; Model "CS".
 - b. Substitutions: See Section 01 6000 - Product Requirements.
- B. Transaction Window. Fixed Glazed Window with Deal Tray and Door.
1. Frames and glass channels: Stainless Steel.
 2. Voice Transmission System: Stainless steel speek through hole with latchable cover.
 3. Glazing: 1/4 inch clear tempered glass.
 4. Base Construction: 18 ga. stainless steel counter with semi-circle stainless steel transation portal and latchable cover, manufacturer's standard.
 5. Finish: as selected from manufacturer's standards.
 6. Size: As indicated.
 7. Manufacturers:
 - a. Nissen, Model SCW102: www.nissenco.com
 - b. Substitutions: See Section 01 6000 - Product Requirements.

2.02 ACCESSORIES

- A. Accessory Materials: Other materials not specifically indicated but required to achieve the results specified; commercial quality.
- B. Sealant: Compatible material of types specified in Section 07 9200.

PART 3 EXECUTION

3.01 EXAMINATION

- A. Verify that field conditions are acceptable and are ready to receive work. Correct conditions detrimental to the proper and timely performance of this work before proceeding with installation. Commencement of work indicates acceptance of substrates.
- B. Verify all opening sizes, dimensions and tolerances in field.

3.02 INSTALLATION

- A. Install in accordance with manufacturer's instructions, level plumb and square.
- B. Fastening to In-Place Construction: Provide anchorage devices and fasteners where necessary for securing components to in-place construction; including threaded fasteners for concrete or masonry inserts, wood screws, and other connectors as required.
- C. Coordinate with installation of countertop.
- D. Seal perimeter for watertight, weatherproof installation.

3.03 ADJUSTING

- A. Repair damaged and defective work and eliminate functional and visual defects. Where repair is not possible replace work. Adjust joints for uniform appearance. No unfinished surfaces or irregularities in completed work.
- B. Adjust operable components for smooth operation.

3.04 CLEANING and PROTECTION

- A. Clean and protect installed units from subsequent construction operations.

END OF SECTION

SECTION 08 6200
UNIT SKYLIGHTS

PART 1 GENERAL

1.01 SECTION INCLUDES

- A. Preformed plastic unit skylights with integral metal frame.

1.02 RELATED SECTIONS

- A. Pertinent Sections specifying Volatile Organic Compound (VOC) Content Restrictions.
- B. Section 06 1000 - Rough Carpentry: Wood framing for rough opening.
- C. Section 07 4113 - Metal Roof Panels: Roofing system and base flashing at skylight curb.
- D. Section 07 6200 - Sheet Metal Flashing and Trim: Skylight counterflashing.
- E. Division 26: Pertinent sections specifying provision of power to motorized skylights or components.

1.03 REFERENCE STANDARDS

- A. AAMA/WDMA/CSA 101/I.S.2/A440 - North American Fenestration Standard/Specification for windows, doors, and skylights.
- B. ASTM B209 - Standard Specification for Aluminum and Aluminum-Alloy Sheet and Plate.
- C. ASTM B209M - Standard Specification for Aluminum and Aluminum-Alloy Sheet and Plate [Metric].
- D. ASTM B221 - Standard Specification for Aluminum and Aluminum-Alloy Extruded Bars, Rods, Wire, Profiles, and Tubes.
- E. ASTM B221M - Standard Specification for Aluminum and Aluminum-Alloy Extruded Bars, Rods, Wire, Profiles, and Tubes [Metric].
- F. ASTM E 84 - Standard Test Method for Surface Burning Characteristics of Building Materials.
- G. ASTM E 283 - Standard Test Method for Determining the Rate of Air Leakage Through Exterior Windows, Curtain Walls, and Doors Under Specified pressure Differences Across the Specimen.
- H. ASTM E 330 - Standard Test Method for Structural Performance of Exterior Windows, Curtain Walls, and Doors by Uniform Static Air Pressure Difference.
- I. ASTM E 331 - Standard Test Method for Water Penetration of Exterior Windows, Skylights, Doors, and Curtain Walls by Uniform Static Air Pressure Difference.
- J. California Code of Regulations, Title 24, Part 2, California Building Code (CBC), International Building Code
- K. California Code of Regulations, Title 24, Part 11 California Green Building Standards Code, "CAL-Green".

1.04 SUBMITTALS

- A. See Section 01 3300 - Submittals, for submittal procedures.
- B. Product Data: Provide structural, thermal, and daylighting performance values.
 - 1. Include current valid ICC-ES Report.

- C. CAL-GREEN Submittals: Product Data – VOC Limits: For adhesives sealants, fillers, primers and coatings, documentation including printed statement of VOC contents, comply with limits specified in related section.
- D. Shop Drawings: Indicate configurations, dimensions, locations, fastening methods, method of routing moisture occurring within system to the exterior, and installation details.
- E. Grade Substantiation: Prior to submitting shop drawings or starting fabrication, submit one of the following showing compliance with specified grade:
 - 1. Evidence of AAMA Certification.
 - 2. Test report(s) by independent testing agency itemizing compliance and acceptable to authorities having jurisdiction.
- F. Manufacturer's Installation Instructions: Indicate special procedures.

1.05 QUALITY ASSURANCE

- A. Manufacturer Qualifications: Company specializing in manufacturing the products specified in this section with not less than three years documented experience.
- B. Installer regularly engaged in the installation of specified skylights for a minimum of five years.
- C. Installer to be factory trained and/or certified by the manufacturer prior to commencement of installation.

1.06 DELIVERY, STORAGE AND HANDLING

- A. Provide strippable material to protect prefinished aluminum surfaces. Do not use adhesive papers or spray coatings which bond when exposed to sunlight or weather.

1.07 PROJECT CONDITIONS

- A. Coordinate the work with the installation of roofing system.

1.08 WARRANTY

- A. See General Conditions, Article 3 The Contractor, for additional warranty submittal requirements.
- B. Provide five year manufacturer warranty for discoloration and leakage including leakage due to defective skylight materials or workmanship.

PART 2 PRODUCTS

2.01 PERFORMANCE REQUIREMENTS

- A. VOC Limits for adhesives, sealants, fillers, primers and coatings . Comply with limits specified in related section.
- B. Maximum flame spread 75, when tested in accordance with ASTM E 84.
- C. Designed, tested and labeled as complying with AAMA/WDMA/CSA 101/I.S.2/A440 in accordance with California Building Code Chapter 24, Section 2405.5:
 - 1. Air infiltration tested in accordance with ASTM E283: Pass.
 - 2. Water resistance tested in accordance with ASTM E331: No leakage.
 - 3. Structural load tests, positive and negative design pressure, tested in accordance with ASTM E330.
- D. Meet the following Area-Weighted Performance Rating values for plastic skylights in accordance with CEC 2016 Building Energy Efficiency Standards Tables 140.3-B or C:
 - 1. Maximum U-factor: 0.88.
 - 2. Maximum Solar Heat Gain Coefficient (SHGC): NR

3. Minimum Visual Transmittance (VT): 0.64, rated using NFRC 203.
- E. Glazing material or diffuser with measured haze value greater than 90 percent, determined according to ASTM D1003, or other test method approved by the California Energy Commission.
- F. Provide unit skylight system which maintains U.L. (Underwriters Laboratories) listing for electrical components, has been evaluated and approved by a product certification body that is certified to be in compliance with ISO Guide 65 to confirm that the product meets or exceeds the requirements of AAMA/WDMA/CSA 101/I.S.2/A440, and maintains a current evaluation report.

2.02 MANUFACTURERS

- A. Unit Skylights:
 1. Crystalite Skylights; Basis of Design: Model Series 5000: www.crystaliteinc.com.
 2. Kingspan Light + Air; Formerly Bristolite Daylighting Systems, Inc; Bristol: www.bristolite.com.
 3. Sun-Tek; CCMT Curb Mounted: www.sun-tek.com.
- B. Substitutions: See Section 01 6000 - Product Requirements.

2.03 UNIT SKYLIGHTS

- A. Unit Skylights: Factory-assembled glazing in aluminum frame, free of visual distortion, and weathertight.
 1. Shape: Rectangular dome.
 2. Glazing: Double.
 3. Operation: None; fixed.
 4. Nominal Size: As indicated.

2.04 PERFORMANCE REQUIREMENTS

2.05 COMPONENTS

- A. Double Glazing: Acrylic plastic; factory sealed.
 1. Outer Glazing: Clear transparent.
 2. Inner Glazing: Clear transparent.
- B. Frames: ASTM B221 (ASTM B221M) Extruded aluminum thermally broken, reinforced and welded corner joints, integral curb frame mounting flange and counterflashing to receive roofing flashing system, with integral condensation collection gutter, glazing retainer; clear anodized finish.
 1. Separate, interlocking retaining caps, with continuous resilient gaskets under and on top of glazing. Metal shall not contact glazing.

2.06 ACCESSORIES

- A. Anchorage Devices: Type recommended by manufacturer, concealed where possible.
- B. Counterflashings: Same metal type and finish as skylight frame.
 1. Minimum thickness: 0.032 inches.
- C. Protective Back Coating: Zinc molybdate alkyd.
- D. Sealant: Polyurethane or copolymer based elastomeric sealant as provided or recommended by the manufacturer.

2.07 FABRICATION

- A. Fabricate free of visual distortion and defects.
- B. Fabricate to achieve leakproof, weathertight assembly.

- C. Fabricate components to allow for expansion and contraction with minimum clearance and shim spacing around perimeter of assembly.

PART 3 EXECUTION

3.01 EXAMINATION

- A. Verify existing conditions before starting work.
- B. Verify that openings and substrate conditions are ready to receive work of this section.

3.02 PREPARATION

- A. Apply protective back coating on aluminum surfaces of skylight units that will be in contact with cementitious materials or dissimilar metals.

3.03 INSTALLATION

- A. Place skylight units and secure in accordance with evaluation report(s) referenced. Install counterflashing as required for watertight assembly.
- B. Apply sealant to achieve watertight assembly.

3.04 FIELD QUALITY CONTROL

- A. Each installed unit to be hose stream tested for leaks before installation of ceiling finishes or insulation.

3.05 CLEANING

- A. Remove protective material from prefinished aluminum surfaces.
- B. Wash down exposed surfaces; wipe surfaces clean.
- C. Remove excess sealant.

END OF SECTION

SECTION 08 7100

DOOR HARDWARE

PART 1 GENERAL

1.01 SUMMARY

- A. Section Includes:
 - 1. All door hardware required to complete the work as indicated on the drawings and as specified herein.
- B. Related Sections/Work Specified Elsewhere
 - 1. Section 08 1113 - Hollow Metal Doors and Frames
 - 2. Section 08 3323 - Overhead Coiling Doors
 - 3. Section 10 1400 - Signage

1.02 REFERENCES

- A. CBC - California Building Code - (Title 24, Part 2, California Code of Regulations (CCR)
- B. ADAAG - Americans with Disabilities Act Accessibility Guidelines
- C. NFPA 80 - Standard for Fire Doors and Other Opening Protectives - National Fire Protection Association
- D. NFPA 252 - Standard Methods of Fire Tests of Door Assemblies - National Fire Protection Association
- E. ANSI A156.1 through A156.20 - American National Standards Institute hardware standards as applicable
- F. U.L. - Underwriters Laboratories, Inc.
- G. BHMA - Builders Hardware Manufacturers Association
- H. DHI - Door and Hardware Institute - "Keying Systems and Nomenclature" and mounting heights/locations procedures and standards

1.03 SUBMITTALS

- A. Submit in accordance with Section 01 3300.
- B. Hardware Schedule
 - 1. Within 30 days following Notice of Award, submit a complete Schedule of Hardware to Architect for review. Schedule criteria:
 - a. Prepare in Door and Hardware Institute (DHI) vertical format only. Horizontal schedules will be rejected.
 - b. Include index of doors, listing door number, page and heading number for each door listed.
 - c. Include a legend of abbreviations, symbols, finishes and manufacturers.
 - d. Schedule each hardware item with quantity, type, manufacturer's model number,

- size/handing as applicable, screws/fasteners, finish, manufacturer's name and any additional information required for proper installation/operation.
- e. List hardware for each door in groups, referencing the same group numbers and numerical group sequence as specified in 3.06 HARDWARE SCHEDULE.
 - f. Include in each hardware group/heading, the door number/location, door and frame types, material, size, thickness, fire rating and any additional door and frame information required for proper installation/operation of hardware.
- C. Review and approval of the Hardware Schedule by Architect does not absolve Contractor of responsibility for missing and/or incorrect items.
- D. When requested, provide the District/Architect, copies of purchase orders showing the dates hardware orders were placed with the factories.
- E. Product Data: Include catalog cut sheets on each type of hardware scheduled to include pictures/drawings, specifications and/or data sheets.
- F. Samples
1. Provide physical samples of hardware as requested by Architect.
 2. Samples will be returned upon request.
 3. Contractor is responsible for cost of samples.
- G. Keying Schedule
1. Within 10 days after approval of the hardware submittal, Contractor to have a keying conference with District/Architect to determine the specific keying requirements of the project.
 2. Pursuant to the keying conference, Contractor shall submit a final Keying Schedule to District/Architect for approval.
- H. Operations and Maintenance Data
1. At contract closeout, provide District with 2 copies of an "Owners Operation and Maintenance Manual". The manual to consist of a hard cover, three-ring binder with the manual's title and project name listed on the outside, front cover. The manual to include:
 - a. Maintenance data for each item of hardware.
 - b. Manufacturer's installation instructions for each hardware item.
 - c. Name, address and phone number of the local representative for each product manufacturer.
 - d. Parts list for each product.
 - e. Copy of final hardware schedule to include all items listed in 1.03 SUBMITTALS, B. and E.
 - f. Copy of final Keying Schedule.
 - g. Manufacturer's warranty for each product.

1.04 QUALITY ASSURANCE/REGULATORY REQUIREMENTS

- A. Substitutions
1. Provide manufacturers of products listed in 2.01 MANUFACTURERS.
 2. Substitution requests to be made only in writing and no later than 10 days prior to bid opening.
 3. Substitutions will not be allowed after the bid.
- B. Supplier Qualifications

1. Hardware supplier to be a recognized finish hardware supplier, regularly engaged in contracting work, who has been furnishing projects of this size and scope in the project's vicinity for a period of not less than 5 years.
2. The firm must have warehousing facilities and a sufficient staff to accommodate a project of this size and scope.
3. The supplier must have in his employ a certified Architectural Hardware Consultant (AHC) who is available at reasonable times during the course of the project for consultation with District, Architect and Contractor.
4. The supplier must be an authorized factory distributor of the key system specified.

C. Installer Qualifications

1. Hardware installer must have at least 2 years experience in installing all types of finish hardware with specific experience in hardware installation on a project of this type and scope.

D. Fire Rated Doors and Frames

1. Provide hardware for fire rated doors and frames in compliance with positive pressure standard NFPA 252 or UL 10C, current edition of NFPA 80 and local building/fire code requirements. Provide only hardware that has been fire tested and positive pressure listed by Underwriters Laboratories (UL) or Warnock Hersey International (WHI) for types and sizes of doors specified and complies with "Fire Door Assembly" codes and requirements of door and frame labels.
2. Provide manufacturer's certificate of compliance or other documentation for each hardware item required to comply with positive pressure standard NFPA 252 or UL 10C.
3. Where emergency exit devices are required on fire rated doors, provide UL or WHI label on exit devices indicating "Fire Exit Hardware".
4. Install closing (self-closing or automatic closing) device on every fire door bearing fire labels.

E. Exit Doors

1. Doors shall be operable from the inside with "non-grasping" trim that does not require the use of a key or any special knowledge.

1.05 DELIVERY, STORAGE AND HANDLING

A. Marking and Packaging

1. Package each hardware item individually in manufacturer's original box/package.
2. Mark all packages with respective door, room, hardware heading and hardware set number.

B. Delivery

1. Deliver all hardware to jobsite unless otherwise directed by Contractor or specified herein.

C. Storage

1. Store all hardware in a dry, secured, enclosed area that is not subject to any corrosive elements that could damage the operation or appearance of the product.

1.06 COORDINATION

A. Templates

1. Distribute door hardware templates for doors, frames and other work specified to be

factory prepared for hardware installation.

2. Review shop drawings of other work to confirm that adequate provisions are made for locating and installing door hardware with requirements specified herein.

1.07 WARRANTY

A. Product Warranties

1. Butt Hinges: Lifetime
2. Continuous Hinges: Lifetime
3. Locksets: 7 years
4. Exit Devices: 10 years
5. Surface Closers: 30 years
6. Remaining hardware warranted for a minimum period of 2 years. The manufacturer's specific product warranty, if greater than 2 years, shall take precedence.

- B. Manufacturer's product warranty to commence from date of substantial completion. The manufacturer is responsible for re-installation of defective product during the warranty period.

1.08 MAINTENANCE

A. Tools and Instructions

1. Provide District at contract closeout, any specialized tools and maintenance instructions required for Owner's adjustment, maintenance, removal and replacement of door hardware.

PART 2 PRODUCTS

2.01 MANUFACTURERS

- A. Provide hardware from listed manufacturers. To match existing District / Campus design, function and security / keying system, provide only the specified manufacturer of scheduled hardware where "Matches Existing" is listed. Refer to 1.04, A. for substitutions.

| <u>HARDWARE ITEM</u> | <u>SPECIFIED MANUFACTURER</u> | <u>APPROVED EQUALS</u> |
|--|-------------------------------------|--|
| Hinges - Butts | HAG Hager | Mckinney, PBB, Stanley, Bommer, Ives or approved equal |
| Continuous Hinges | SEL Select | Ives, Roton, ABH, Pemko, Stanley, McKinney or approved equal |
| Locksets, Cylinders, Deadlocks | SCH Schlage | Matches Existing |
| Exit Devices | VON Von Duprin | Matches Existing |
| Closers | LCN | Matches Existing |
| Protective Plates, Stops, Flush Bolts, Misc. | ROC Rockwood | Burns, Trimco, Ives, Glynn-Johnson or approved equal |
| Overhead Stops and Holders | ABH Architectural Builders Hardware | Glynn-Johnson or approved equal |
| Thresholds, Sweeps, Seals | PEM Pemko | Zero, Reese, National |

Key Cabinets

MMF MMF Industries

Guard or approved equal
Bommer, Telkee or
approved equal

2.02 MATERIALS

A. Screws and Fasteners

1. Install all hardware only with screws and fasteners furnished with hardware.
2. Where a specific type of hardware is packaged by the manufacturer with "screws and fasteners by others", install hardware with manufacturer's recommended type(s).
3. Finish to match hardware.

B. Hinges (butts)

1. Unless otherwise specified, furnish full mortise, template type butts with non-rising loose pins.
2. Furnish Hager as specified or approved equal as listed in 2.01, A. Provide:
 - a. 4.5 x 4.5 size for doors up to 3'0" wide.
 - b. 5 x 4.5 size for doors 3'1" and wider.
 - c. Three hinges for doors less than 7'6" tall and four hinges for doors 7'6" tall and greater.
 - d. Exterior, out-swinging door hinges in non-ferrous material with stainless steel, Non Removable Pin (NRP).
 - e. Interior hinges in wrought steel, polished and plated to match specified finish of other hardware. NRP at all out-swinging doors with keyed locksets.
 - f. Hinges of sufficient width, where required to clear frame and trim, to allow door to open 180 degrees.

C. Continuous Hinges

1. Furnish Select geared type as specified or approved equal listed in 2.01, A.

D. Locks

1. Except where otherwise specified, furnish all locksets, latchsets, cylinders and component parts by Schlage as specified. Provide:
 - a. Lock series and trim/design as specified.
 - b. Locksets and cylinders with Everest cylinder in keyway as directed by the District.
 - c. Box strikes as required by frame types with sufficient length lip to prevent latch bolt from damaging trim.

E. Exit Devices

1. Conform to ANSI A156.3 Grade 1 Standard.
2. Comply with CBC 309.4 Operation: The force required to activate operable parts...push bar force required to retract latch...shall be 5 pounds maximum.
3. Furnish Von Duprin as specified.

F. Closers

1. Comply with CBC opening force requirements.
 - a. Interior non-rated doors - 5 lbs.
 - b. Exterior doors - 5 lbs.
 - c. Fire doors to have minimum opening force allowable by the appropriate authority having jurisdiction, not to exceed 15 lbs.
2. Surface Closers
 - a. Conform to ANSI A156.4 Grade 1 Standard. Furnish LCN as specified. Provide:

- 1). Non-handed type that allows 180-degree door opening.
- 2). Drop plates, back plates, brackets, mortise shoes, spacer blocks and long arms as required.
- 3). Parallel arm closers with heavy-duty arm (EDA).
- 4). Multi-size, power adjustable type with independent latch speed, sweep speed and back check cushioning valve controls.

G. Protective Plates

1. Furnish Rockwood kick plates as specified or approved equal listed in 2.01, A. Provide:
 - a. .050 thick.
 - b. Beveled 4 edges.
 - c. Sizes specified.

H. Stops and Holders

1. Furnish Rockwood as specified or approved equal listed in 2.01, A.
2. Where conditions will not allow installation of wall or floor stops as specified in 3.02 INSTALLATION, furnish overhead stop ABH 9000 series.

I. Thresholds, Sweeps and Seals

1. Furnish Pemko as specified or approved equal listed in 2.01, A.
2. Provide per plan details and as specified in 3.06 HARDWARE SCHEDULE.
3. Thresholds shall not exceed ½" in height with a slope no greater than 1:2.
 - a. Furnish with appropriate screws and anchors for floor material.

J. Silencers

1. For frames without seals, provide push-in type silencers. Self-adhesive type is not allowed. Provide:
 - a. Pairs of doors: 2 each
 - b. Single doors: 3 each

K. Miscellaneous Hardware

1. Provide remaining hardware items as specified in 3.06 HARDWARE SCHEDULE. The manufacturers and model numbers listed establish design, function and quality requirements.

2.03 FINISHES

- A. Provide finishes specified in 3.06 HARDWARE SCHEDULE. BHMA finish designation indicates base metal as well as finish.

2.04 KEYING

- A. Refer to 1.03, G. Keying Schedule for requirements for preparation of specific keying schedule.
- B. Factory key all locksets and cylinders:
 1. Master key/grand master and/or higher level key as required
 2. Construction master key
- C. Furnish the following keys and related items:
 1. 2 blanks and 2 change per keyed different lock
 2. 4 each keyed alike set

3. 5 masters each MK set
4. 2 grand masters and/or higher level keys as required
5. 10 construction masters
6. 1 bitting list

D. Stamp all key bows with "DO NOT DUPLICATE" and with any other inscription as directed by the District/Architect.

E. Tag all permanent keys with door and hardware heading numbers and deliver to District.

2.05 KEY CONTROL

A. Key Cabinet

1. Provide MMF Industries STEELMASTER Dupli-Key model or approved equal products listed in 2.01, A.
2. Furnish with key lock and all accessories.
3. Cabinet size to accommodate 125 percent of total number of locks and cylinders.
4. Deliver cabinet to District prior to building occupancy.
5. The District is responsible for installation and hanging of keys on hooks.

PART 3 EXECUTION

3.01 EXAMINATION

- A. Prior to installation of hardware, examine doors, frames and related items for defects or other conditions that would prevent the proper installation and operation of specified hardware. Do not proceed with hardware installation until deficiencies are corrected.

3.02 INSTALLATION

- A. Install hardware in accordance with manufacturer's instructions.
- B. Surface Closers
1. Install inside rooms, in stairwells and inside vestibules. Do not mount closers in corridors except at exterior doors that open off a corridor.
 2. Install with sex nuts and bolts.
 3. Template for maximum degree of opening:
 - a. Parallel arm: 180 degrees
 - b. Regular arm: Maximum degree listed by manufacturer
 - 1). Where adjacent wall, obstruction or closer stop type arm will not permit maximum degree of opening, install closers to allow the maximum degree of opening allowed by the stop arm or before door contacts wall or obstruction. In no instance are closers to be templated for less than 90 degree opening.
 4. Adjust closers per 2.02, F. and comply with closer sweep requirements so that from an open position of 90 degrees, the time required to move door to a position 12 degrees from the latch is 5 seconds minimum.
- C. Exit Devices
1. Install with sex nuts and bolts.
- D. Kick Plates
1. Install plates on push side of door unless otherwise specified.

2. Install only with screws furnished.
3. Align centered between door edges and with bottom edge flush with door bottom.
4. Plates are to fit flat against the face of the door without any modification to the plate.
5. Replace plates of incorrect size that encroach on glass area, hang below door bottom or extend beyond door edges.

F. Stops

1. Floor Stops:
 - a. Install in a position that permits maximum door swing but does not exceed 4" from wall.
 - b. Furnish stops of proper height to engage door.
 - c. Position to contact the door at a point 6 inches from the latch edge, but no further than 1/3 the door width as measured from the latch edge.
2. Wall Stops:
 - a. Fasten to solid blocking/backing.
 - b. Install at height that will engage operating trim/levers.

G. Thresholds

1. Set in full bed of sealant complying with requirements specified in Division 07 Section "Joint Sealers".
2. Secure to concrete with flat head machine screws and expansion anchors.

H. Seals

1. As required, notch jamb seals around hardware items (closer arms, strikes, etc.).

I. Fasten miscellaneous wall-mounted hardware to solid blocking/backing.

J. Unless otherwise specified, all hardware mounting heights shall be per drawings, CBC and/or Door and Hardware Institute (DHI) mounting location standards. Operating/opening hardware shall be installed between 34" minimum and maximum 44" centerline above finished floor.

3.03 FIELD QUALITY CONTROL

A. After hardware installation has been completed, Architect, District's representative and/or project inspector shall:

1. Visually inspect installed hardware to determine compliance with the approved hardware and keying schedules.
2. Cycle doors to determine proper operation of hardware.

3.04 ADJUSTING AND CLEANING

A. At the end of project, clean and make final adjustments to all hardware. Where hardware is found defective, repair or replace as directed.

3.05 PROTECTION

A. Provide proper care and protection for all hardware items and finishes until completion of project.

3.06 HARDWARE SCHEDULE

A. The following is a schedule of hardware to be furnished for this work. The listed material to conform throughout with the requirements of the foregoing specification.

HW-1

Each door to have

| | | | | |
|---|------------------|--------------------|-----|-----|
| 1 | Continuous Hinge | SL11HD | 628 | SEL |
| 1 | Entrance Lockset | ND92LD RHO | 626 | SCH |
| 1 | Closer | 4040XP EDA | 689 | LCN |
| 1 | Kick Plate | K1050 10" x 2" LDW | 630 | ROC |
| 1 | Floor Stop | 463 | 630 | ROC |
| 1 | Threshold | Per detail | | PEM |
| 1 | Sweep | 29326CNB | | PEM |
| 1 | Set Seals | S88GR | | PEM |

HW-2

Each door to have

| | | | | |
|---|-------------------|------------|-----|-----|
| | Hinges | BB1279 | 652 | HAG |
| 1 | Storeroom Lockset | ND96LD RHO | 626 | SCH |
| 1 | Floor Stop | 481 | 626 | ROC |

HW-3

Each door to have

| | | | | |
|---|--------------------|---|-----|-----|
| 1 | Continuous Hinge | SL11HD | 628 | SEL |
| 1 | Classroom Deadlock | B663 x Everest x install 44" centerline AFF | 626 | SCH |
| 1 | Push Plate | 70F x install below deadlock | 630 | ROC |
| 1 | Pull Plate | 70C x BF110 x install below deadlock | 630 | ROC |
| 1 | Closer | 4040XP Reg | 689 | LCN |
| 1 | Kick Plate | K1050 10" x 2" LDW | 630 | ROC |
| 1 | Floor Stop | 481 | 626 | ROC |
| 1 | Threshold | Per detail | | PEM |
| 1 | Sweep | 29326CNB | | PEM |
| 1 | Set Seals | S88GR | | PEM |

HW-4

Each door to have

| | | | | |
|---|--------------------|--------------------|-----|-----|
| 1 | Continuous Hinge | SL11HD | 628 | SEL |
| 1 | Entrance Lockset | ND92LD RHO | 626 | SCH |
| 1 | Closer/Stop/Holder | 4040XP SHCUSH | 689 | LCN |
| 1 | Kick Plate | K1050 10" x 2" LDW | 630 | ROC |
| 1 | Threshold | Per detail | | PEM |
| 1 | Sweep | 29326CNB | | PEM |
| 1 | Set Seals | S88GR | | PEM |

HW-5

Each door to have

| | | | |
|--------------------|--------------------|-----|-----|
| Hinges | BB1279 | 652 | HAG |
| 1 Entrance Lockset | ND92LD RHO | 626 | SCH |
| 1 Kick Plate | K1050 10" x 2" LDW | 630 | ROC |
| 1 Overhead Stop | 9000 series | 630 | ABH |

HW-6

Each door to have

| | | | |
|----------------------|--------------------|-----|-----|
| 1 Continuous Hinge | SL11HD | 628 | SEL |
| 1 Entrance Lockset | ND92LD RHO | 626 | SCH |
| 1 Closer/Stop/Holder | 4040XP SHCUSH | 689 | LCN |
| 1 Kick Plate | K1050 10" x 2" LDW | 630 | ROC |
| 1 Threshold | Per detail | | PEM |
| 1 Sweep | 29326CNB | | PEM |
| 1 Set Seals | S88GR | | PEM |

HW-7

Each door to have

| | | | |
|---------------------|--------------------|-----|-----|
| Hinges | BB1279 | 652 | HAG |
| 1 Storeroom Lockset | ND96LD RHO | 626 | SCH |
| 1 Closer | 4040XP Reg | 689 | LCN |
| 1 Kick Plate | K1050 10" x 2" LDW | 630 | ROC |
| 1 Floor Stop/Holder | 491S | 626 | ROC |

HW-8

Each door to have

| | | | |
|---------------------|--------------------|-----|-----|
| Hinges | BB1279 | 652 | HAG |
| 1 Entrance Lockset | ND92LD RHO | 626 | SCH |
| 1 Closer | 4040XP Reg | 689 | LCN |
| 1 Kick Plate | K1050 10" x 2" LDW | 630 | ROC |
| 1 Floor Stop/Holder | 491S | 626 | ROC |

HW-9

Each door to have

| | | | |
|-----------------------------------|--------------------|-----|-----|
| 1 Continuous Hinge | SL11HD | 628 | SEL |
| 1 Entrance/Office/Privacy Lockset | ND91LD RHO | 626 | SCH |
| 1 Closer | 4040XP Reg | 689 | LCN |
| 1 Kick Plate | K1050 10" x 2" LDW | 630 | ROC |
| 1 Floor Stop | 481 | 626 | ROC |
| 1 Threshold | Per detail | | PEM |
| 1 Sweep | 29326CNB | | PEM |
| 1 Set Seals | S88GR | | PEM |

HW-10

Each pair to have

| | | | | |
|---|-----------------------|-----------------------------|-----|-----|
| 2 | Continuous Hinges | SL11HD | 628 | SEL |
| 2 | Flush Bolts | 555 | 626 | ROC |
| 1 | Dust Proof Strike | 570 | 626 | ROC |
| 1 | Storeroom Lockset | ND96LD RHO | 626 | SCH |
| 1 | Closer/Stop/Holder | 4040XP SHCUSH @ active leaf | 689 | LCN |
| 2 | Kick Plates | K1050 10" x 1 1/2" LDW | 630 | ROC |
| 1 | Overhead Stop | 9000 series @ inactive leaf | 630 | ABH |
| 1 | Threshold | Per detail | | PEM |
| 2 | Sweeps | 29326CNB | | PEM |
| 1 | Set Seals | S88GR | | PEM |
| 1 | Welded Steel Astragal | By door mfr./supplier' | | |

HW-11

Each door to have

| | | | | |
|---|------------------|-------------------------|-----|-----|
| 1 | Continuous Hinge | SL11HD | 628 | SEL |
| 1 | Exit Device | AX-99NL-F-2SI | 626 | VON |
| 2 | Cylinders | Type and model required | 626 | SCH |
| 1 | Closer/Stop | 4040XP SCUSH | 689 | LCN |
| 1 | Kick Plate | K1050 10" x 2" LDW | 630 | ROC |
| 1 | Threshold | Per detail | | PEM |
| 1 | Sweep | 29326CNB | | PEM |
| 1 | Set Seals | S88GR | | PEM |

HW-12

Each door to have

| | | | | |
|---|------------------|-------------------------|-----|-----|
| 1 | Continuous Hinge | SL11HD | 628 | SEL |
| 1 | Exit Device | AX-99NL-F-2SI | 626 | VON |
| 2 | Cylinders | Type and model required | 626 | SCH |
| 1 | Closer | 4040XP EDA | 689 | LCN |
| 1 | Kick Plate | K1050 10" x 2" LDW | 630 | ROC |
| 1 | Floor Stop | 463 | 630 | ROC |
| 1 | Threshold | Per detail | | PEM |
| 1 | Set Sweep | 29326CNB | | PEM |
| 1 | Set Seals | S88GR | | PEM |

END OF SECTION



ALLEGION



Lever designs

Athens (ATH)

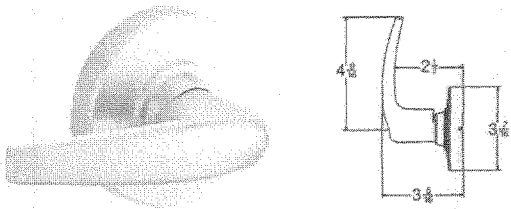

Material: Pressure cast zinc lever; wrought brass rose



Sparta (SPA)

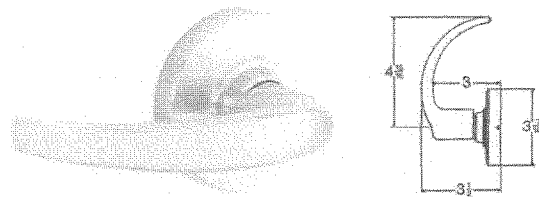

Material: Pressure cast zinc lever; wrought brass rose



Rhodes (RHO)

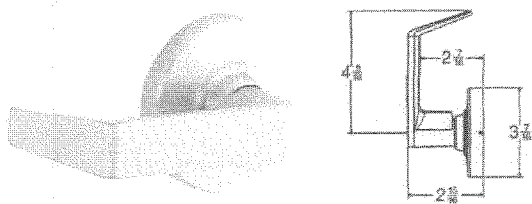

Material: Pressure cast zinc lever; wrought brass rose



Tubular (TLR)

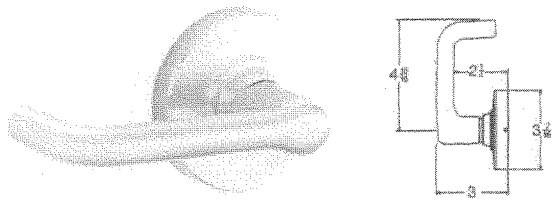

Material: Pressure cast zinc lever; wrought brass rose







Omega (OME)

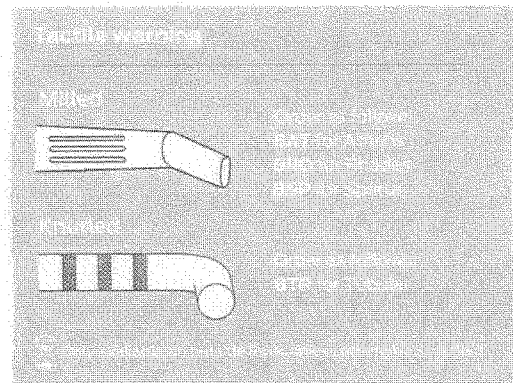



Material: Pressure cast zinc lever; wrought brass rose



All designs shown in 626 satin chrome

-  = Standard cylinder.
-  = FSIC - Full size interchangeable core option.
-  = SFIC - Small format interchangeable core option.
-  = Complies with ADA accessibility guidelines.

-  = Antimicrobial coating available on 626 finish only.
-  = Meets California code for 1/2" or less return to the door.
-  = Extended factory lead time.

Ordering instructions

Order using standard Schlage order form as follows:

| ND Series electrified cylindrical lock | | | | | | |
|--|----------|--------------|------|--------|----------------|----------|
| Function | Cylinder | Latch suffix | Trim | Finish | Door thickness | Options |
| ND80EU | P | D | RHO | 626 | 1 3/4" | N523-194 |

| Lock specifications | | | |
|---------------------|--|--|---|
| Function | ND12EL/EU, ND80EL/EU, ND96 EL/EU (see front of datasheet for model details) Specifying EL or EU provides the factory pre-set position; setting can easily be changed in field by moving a switch on the lock chassis. | | |
| Cylinder | Standard P (Everest 29) L (Less cylinder) C (Less double cylinder) Cylinder code N/A for ND12 | FSIC R (Everest 29 FSIC) J (Less FSIC) T (Construction FSIC) | SFIC G (Everest 29 SFIC) B (Less SFIC) BDC (Disposable SFIC) H (Construction SFIC) |
| Latch suffix | D for deadlatch functions (all models except ND10 passage, ND30 Patio, ND40 privacy, ND44 hospital privacy) S for springlatch functions (ND10 passage, ND30 Patio, ND40 privacy, ND44 hospital privacy only) | | |
| Trim | ATH, OME, SPA, RHO, TLR | | |
| Finish | 605 Bright brass 606 Satin brass 612 Satin bronze | 613 Oil rubbed bronze 619 Satin nickel 625 Bright chrome | 626 Satin chrome 626AM Satin chrome anti-microbial 643e Aged bronze |
| Handing | LH (Left Hand) LR (Left Hand Reverse) | RH (Right Hand) RR (Right Hand Reverse) | |
| Door thickness | 1 5/8" - 2 1/8" standard; see pricebook for additional thicknesses | | |
| Option | Specify "RX" for Request to Exit. See pricebook for additional options. | | |

Note: Mixed lever designs and finishes available; please see pricebook for details.

| Wire length | | | | |
|-------------|---------------------|-------------|-------------|-------------|
| AWG | 14 | 16 | 18 | 20 |
| 12 volt | 500' (152 m) | 300' (90 m) | 200' (61 m) | 100' (30 m) |
| 24 volt | Up to 1000' (304 m) | | | |

Allegion Connect

The ND Series electrified cylindrical lock comes standard with Allegion Connect, a factory-installed Molex connector system that utilizes quick-connect harnesses and hinges for simplified installation and maintenance. Alternately, the connector can be cut off and the lock installed with traditional wire splicing methods. Note that the Allegion Connect harnesses and hinges are sold separately.

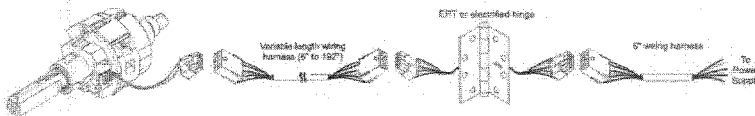

| Allegion Connect cables | Door type | |
|------------------------------|--------------|----------|
| | Hollow metal | Wood |
| 6" wire harness | Con-6 | Con-6P |
| 12" wire harness | Con-12 | Con-12P |
| 26" wire harness | Con-26 | Con-26P |
| 32" wire harness | Con-32 | Con-32P |
| 38" wire harness | Con-38 | Con-38P |
| 44" wire harness | Con-44 | Con-44P |
| 50" wire harness | Con-50 | Con-50P |
| 192" wire harness | Con-192 | Con-192P |
| 6" extension to power supply | Con-6W | Con-6W |

Note: Harness for hollow metal doors have connectors both ends; wood door harness comes w/connector on one-end with crimped pins on other w/attachable connector (required in wood doors due to more narrow cable raceway)

About Allegion

Allegion (NYSE: ALLE) is a global pioneer in safety and security, with leading brands like CISA® Interflex®, LCN®, Schlage® and Von Duprin®. Focusing on security around the door and adjacent areas, Allegion produces a range of solutions for homes, businesses, schools and other institutions. Allegion is a \$2 billion company, with products sold in almost 130 countries. For more, visit www.allegion.com.

aptiQ ■ LCN ■ **Schlage** ■ STEELCRAFT ■ VON DUPRIN



© 2016 Allegion
010875, Rev. 02/16
www.allegion.com/us



Standard cylinder.



FSIC - full size interchangeable core option.



Safe school locks.



SFIC - small format interchangeable core option.

Caution:

Double cylinder locks are a life safety hazard in times of emergency and their use is not recommended. Installation should be in accordance with existing codes only.

Schlage ANSI
ND92PD F109

Entrance lock

- Turn/push-button locking: Pushing and turning button disengages outside lever, requiring using of key until button is manually unlocked.
- Push-button locking: Pushing button disengages outside lever until unlocked by key or by turning inside lever.
- Vandigard is designed to disengage outside spindle from latch when locked.

Outside Inside

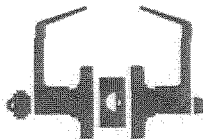

Schlage ANSI
ND93PD F88

Vestibule lock

- Latch retracted by key from outside when outside lever is disengaged by key in inside lever.
- Inside lever is always unlocked.
- Vandigard is designed to disengage outside spindle from latch when locked.

Outside Inside

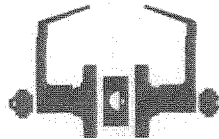

Schlage ANSI
ND94PD F84

Classroom lock

- Outside lever disengaged and unlocked by key.
- Inside lever always unlocked.
- Vandigard is designed to disengage outside spindle from latch when locked.

Outside Inside



Schlage ANSI
ND95PD -

Classroom security lock

- Key in either lever locks or unlocks outside lever.
- Inside lever is always unlocked.

Outside Inside

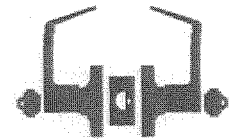

Schlage ANSI
ND96PD F86

Storeroom lock

- Outside lever always disengaged.
- Entrance by key only.
- Inside lever is always unlocked.
- Vandigard is designed to disengage outside spindle from latch when locked.

Outside Inside

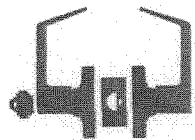

Available with RX feature



Schlage ANSI
ND96PDEL -

Electrically locked (fail safe)

- Outside lever continuously disengaged electrically.
- Unlocked by key outside or by switch or power failure.
- Auxiliary latch deadlocks latchbolt when door is closed.
- Inside lever always free for immediate exit.
- Vandigard is designed to disengage outside spindle from latch when locked.

Outside Inside

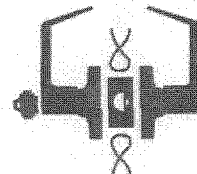

Schlage ANSI
ND96PDEU -

Electrically unlocked (fail secure)

- Outside lever continuously disengaged until unlocked by key or electric current.
- Auxiliary latch deadlocks latchbolt when door is closed.
- Inside lever always free for immediate exit.
- Vandigard is designed to disengage outside spindle from latch when locked.

Outside Inside

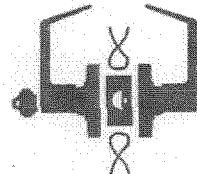



Schlage ANSI
ND97PD F90

Corridor lock

- Locked or unlocked by key from outside.
- Push-button locking from inside.
- Turning inside lever or closing door releases button.
- When outside lever is locked by key it can only be unlocked by key.
- Inside lever is always unlocked.
- Vandigard is designed to disengage outside spindle from latch when locked.

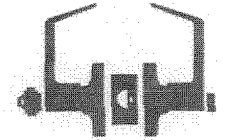
Outside Inside



 Standard cylinder.

 FSIC - full size interchangeable core option.

 Safe school locks.

 SFIC - small format interchangeable core option.

Caution:

Double cylinder locks are a life safety hazard in times of emergency and their use is not recommended. Installation should be in accordance with existing codes only.

Keyed locks

Schlage ANSI
ND40S F76

Bath/bedroom
privacy lock

- Push-button locking.
- Can be opened from outside with a small screwdriver.
- Turn inside lever or close door to release button.

Outside Inside

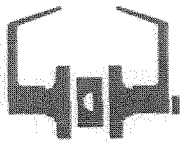

Schlage ANSI
ND44S -

Hospital privacy lock

- Push-button locking.
- Unlocked from outside by turning emergency turn-button.
- Turn inside lever or close door to release button.

Outside Inside

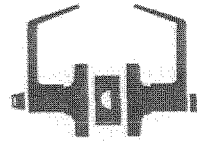

Schlage ANSI
ND170 -

Single dummy trim

- Dummy trim for one side of door.
- Used for door pull or as matching inactive trim.

Outside/Inside



Schlage ANSI
ND50PD F82

Entrance/office lock

- Push-button locking.
- Push-button locks outside lever until it is unlocked with key or by turning inside lever.

Outside Inside

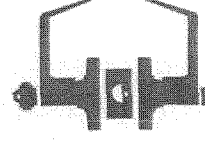

Schlage ANSI
ND53PD F109

Entrance lock

- Turn/push-button locking: Pushing and turning the button locks the outside lever, requiring use of a key until the button is manually unlocked.
- Push-button locking: Pushing button locks outside lever until unlocked by key or by turning the inside lever.

Outside Inside

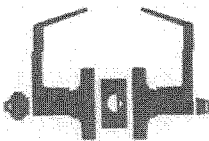

Schlage ANSI
ND60PD F88

Vestibule lock

- Latch retracted by key from outside when outside lever is locked by key in inside lever.
- Inside lever always unlocked for immediate egress.

Outside Inside

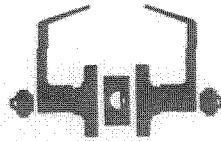

Schlage ANSI
ND66PD F91

Store lock?

- Key in either lever locks or unlocks both levers.

Outside Inside

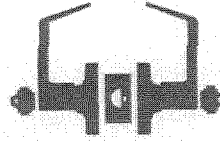

Schlage ANSI
ND70PD F84

Classroom lock

- Outside lever locked and unlocked by key.
- Inside lever always unlocked.

Outside Inside

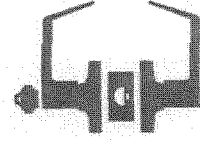

LOCK FUNCTION

ANSI A156.2 Series 4000 Grade 1

Keyed locks (continued)

Schlage ANSI
ND73PD F90

Corridor lock

- Locked or unlocked by key from outside.
- Push-button locking from inside.
- Turn inside lever or close door to release button.
- When outside lever is locked by key it can only be unlocked by key.
- Inside lever is always unlocked.

Outside Inside

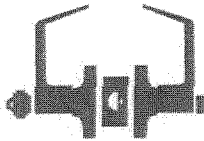

Schlage ANSI
ND75PD -

Classroom security lock

- Key in either lever locks or unlocks outside lever.
- Inside lever is always unlocked.

Outside Inside

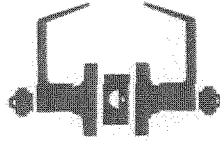

Schlage ANSI
ND80PD F86

Storeroom lock

- Outside lever is fixed.
- Entrance by key only.
- Inside lever always unlocked.

Outside Inside

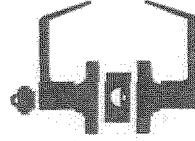

Available with RX feature



Schlage ANSI
ND80PDEL -

Electrically locked (fail safe)

- Outside lever continuously locked electrically.
- Unlocked by key outside or by switch or power failure.
- Auxiliary latch deadlocks latchbolt when door is closed.
- Inside lever always free for immediate exit.

Outside Inside

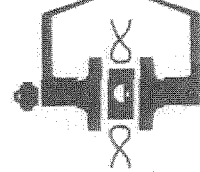

Schlage ANSI
ND80PDEU -

Electrically unlocked (fail secure)

- Outside lever continuously locked until unlocked by key or electric current.
- Auxiliary latch deadlocks latchbolt when door is closed.
- Inside lever always free for immediate exit.

Outside Inside

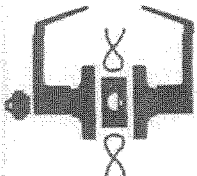

Schlage ANSI
ND82PD F87

Institution lock

- Both levers are fixed.
- Entrance by key in either lever.

Outside Inside

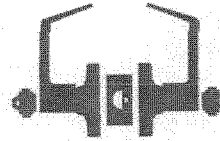

Schlage ANSI
ND85PD -

Faculty restroom lock

- Outside lever is fixed.
- Entrance by key only.
- Push-button in inside lever activates visual occupancy indicator, allowing only emergency master key to operate.
- Turn inside lever or close door to release visual occupancy indicator.
- Rotation of inside spinner-button provides lock-out feature by keeping indicator thrown.

Outside Inside

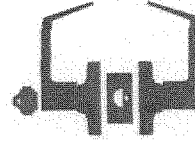

Schlage ANSI
ND91PD F82

Entrance/office lock

- Push-button locking.
- Push-button disengages outside lever until locked with key or by turning inside lever.
- Vandigard is designed to disengage outside spindle from latch when locked.

Outside Inside

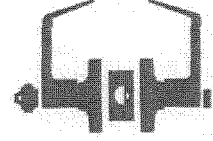

Vandigard functions

98/99 Rim exit device

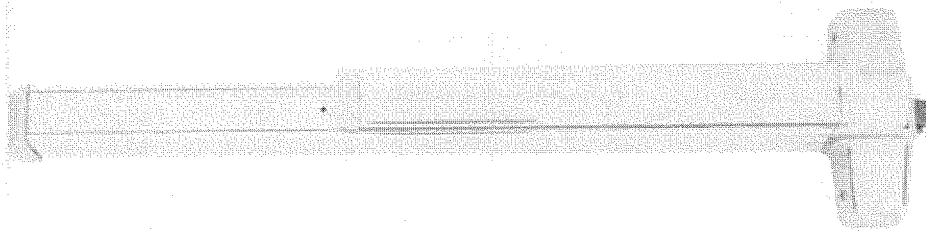

The 299 Strike ships standard, optional strikes available

98 and 99 Rim exit devices for all types of single and double doors with mullion, UL listed for panic exit hardware. Devices are ANSI A156.3 – 2001 Grade 1. The 98 device has a smooth mechanism case and the 99 device has a grooved case. The rim device is non-handed except when the following device options are used: SD (special dogging), -2 (double cylinder) or SS (signal switch). See Opposite page for available outside trim and device functions. Covers stock hollow metal doors with 86 or 161 cutouts on single doors (may cover cutouts on pairs – consult template).

Hex key dogging comes standard on 98/99 Rim exit devices



Finishes – US3, US3A, US4, US4A, US10, US26, US26D, US26D-AM Antimicrobial, US28, 313, 315 & 643E. US15 and US32D available with 98 Series only.

Specifications

| | | |
|---------------------------------------|---|---|
| Device functions | Device ships EO/DT/NL. Field selectable. For TP, K or L remove NL drive screw from device. | |
| Device lengths | 3' | 2'4" to 3' (711mm to 914 mm) Door size |
| | 4' | 2'10" to 4' (864 mm to 1219 mm) Door size |
| Device centerline from finished floor | 39 ³ / ₁₆ " (1011 mm) 39 ³ / ₁₆ " (1008 mm) with mullion | |
| Center case dimensions | 8" x 2 ³ / ₄ " x 2 ³ / ₈ " (203mm x 70mm x 60mm) | |
| Mechanism case dimensions | 2 ¹ / ₄ " x 2 ¹ / ₄ " (57mm x 57mm) | |
| Projection | Pushbar neutral – 3 ¹ / ₁₆ " (97 mm) Pushbar depressed – 3 ¹ / ₁₆ " (78 mm) | |
| Latch bolt | Deadlocking, ³ / ₄ " (19mm) throw | |
| Fasteners & sex bolts (SNB) | Includes screw pack for 1 ¹ / ₄ " (44mm) and 2 ¹ / ₄ " (57mm) thick metal or wood doors. Optional 425 SNB available, see page 9 for quantities. | |
| Electric options | LX | Latchbolt monitor switch |
| | RX | Pushpad monitor switch |
| | RX2 | Double pushpad monitor switch |
| | E | Electric locking & unlocking trim |
| | EL | Electric latch retraction |
| | QEL | Quiet electric latch retraction |
| | SS | Signal switch |
| | CX | Chexit delayed exit |
| | ALK | Alarm exit kit |
| | WP-RX | Waterproof request to exit |
| | CON | Allegion Connect |
| Mechanical options | -2 | Double cylinder |
| | AX | Accessible device |
| | GBK | Glass bead kit |
| | PN | Pneumatic latch retraction |
| | XP | Extra protection |
| | SNB | Sex bolts |
| | SEC | Security screws |
| Dogging feature | Hex key dogging standard | |
| Dogging option | CD | Cylinder dogging |
| | SD | Special center case dogging |
| | LD | Less dogging |
| | DI | Dogging indicator |
| | CI | Cylinder dogging indicator |
| Strikes | 299 – Dull black | |

XP
Extra protection

- 90° latch-to-strike contact
- Force resistance of 2,000+ lbs.

CD
Cylinder dogging

- Replaces hex key dogging
- Requires standard 1¹/₄" mortise cylinder

QEL
Quiet electric latch retraction

- Bolt retraction via switch
- Converts exit door to push-pull operation

RX
Pushpad monitor switch

- Signals use of an opening
- SPDT switch to monitor pushpad

CX
Chexit delayed exit

- Meets NFPA 101 requirements
- Self-contained controls, locking, alarm

AX
Accessible device

- UL certified to meet new 5 lb. maximum operating force requirement
- Exceeds ANSI/BHMA requirements

EL
Electric latch retraction

- Enables remote unlatching
- Alternative to manual dogging

ALK
Alarm exit kit

- Unauthorized opening triggers 85-decibel horn
- Set in armed or disarmed mode by key

PN
Pneumatic latch retraction

- For areas where electrical devices banned
- Special linkage for mechanical or pneumatic dogging

CON
Allegion Connectors

- Common connectors to connect various door hardware all the way to the power supply

Nomenclature – how to order

| | | EL | 99 | 27 | -L | -16 | -F | LBR | 3' | US3 | RHR |
|----------|---|----|----|----|----|-----|----|-----|----|-----|-----|
| None | Standard | | | | | | | | | | |
| SD | Special dogging R/VR - panic only | | | | | | | | | | |
| CD | Cylinder dogging - panic only | | | | | | | | | | |
| CX | Chexit | | | | | | | | | | |
| E | Electric locking mortise/lever | | | | | | | | | | |
| CEL | Quiet electric latch retraction | | | | | | | | | | |
| EL | Electric latch retraction | | | | | | | | | | |
| LX | Latch bolt monitoring | | | | | | | | | | |
| RX | Request to exit | | | | | | | | | | |
| RX2 | Double request to exit | | | | | | | | | | |
| SS | Signal switch | | | | | | | | | | |
| AX | Accessible device | | | | | | | | | | |
| PL | Pullman latch | | | | | | | | | | |
| PN | Pneumatic latch retraction | | | | | | | | | | |
| VIS | Surface vertical rod exit device | | | | | | | | | | |
| XP | Heavy protection - rim | | | | | | | | | | |
| WS | Tornado & hurricane tested | | | | | | | | | | |
| 98 | Series 98-smooth | | | | | | | | | | |
| 99 | Series 99-grooved | | | | | | | | | | |
| None | Rim device | | | | | | | | | | |
| 27 | Surface mounted vertical rod device | | | | | | | | | | |
| 47 | Concealed vertical rod device | | | | | | | | | | |
| 47WDC | Concealed vertical rod wood door device | | | | | | | | | | |
| 48 | Concealed vertical rod device | | | | | | | | | | |
| 49 | Concealed vertical cable device | | | | | | | | | | |
| 49WDC | Concealed vertical cable wood door device | | | | | | | | | | |
| 57 | Three-point latch device | | | | | | | | | | |
| 75 | Mortise lock device | | | | | | | | | | |
| XX | AD Trim (to come from client) | | | | | | | | | | |
| DT | Dummy trim | | | | | | | | | | |
| EO | Exit only | | | | | | | | | | |
| HL | Hospital pull trim | | | | | | | | | | |
| K | Knob | | | | | | | | | | |
| K-BE | Knob - blank escutcheon | | | | | | | | | | |
| K-DT | Knob, rigid - dummy trim | | | | | | | | | | |
| K-NL | Knob, rigid - night latch | | | | | | | | | | |
| L | Lever (classroom) | | | | | | | | | | |
| L-BE | Lever - blank escutcheon | | | | | | | | | | |
| L-DT | Lever, rigid - dummy trim | | | | | | | | | | |
| L-NL | Lever, rigid - night latch | | | | | | | | | | |
| NL | Night latch | | | | | | | | | | |
| NL-OP | Night latch cylinder assembly, optional pull | | | | | | | | | | |
| TL | Turn lever | | | | | | | | | | |
| TL-BE | Turn lever - blank escutcheon | | | | | | | | | | |
| TP | Thumbpiece | | | | | | | | | | |
| TP-BE | Thumbpiece - blank escutcheon | | | | | | | | | | |
| XX | Lever style 06 standard Optional 01, 02, 03, 05, 07, 12 (Handed), 16 (Omega), 17, 18, Accent, Asti, Merano, St. Annes | | | | | | | | | | |
| F | Fire exit device | | | | | | | | | | |
| -2 | Double cylinder (rim & mortise only) | | | | | | | | | | |
| LBR | Less bottom rod | | | | | | | | | | |
| LBL | Less bottom latch | | | | | | | | | | |
| SG | Safety glow (luminescent) touchpad | | | | | | | | | | |
| ALK | Alarm kit | | | | | | | | | | |
| ALK-AR1 | Auto-reset 1 1/2 minute alarm kit | | | | | | | | | | |
| ALK-AR3 | Auto-reset 3 minute alarm kit | | | | | | | | | | |
| ALK-AR6 | Auto-reset 4 1/2 minute alarm kit | | | | | | | | | | |
| CON | Allegion Connect | | | | | | | | | | |
| 2' | 2' Device (2' door size) 27, 47 or 49 only | | | | | | | | | | |
| 3' | 3' Device (2' 4"- 3' door size) | | | | | | | | | | |
| 4' | 4' Device (2' 10"- 4' door size) | | | | | | | | | | |
| Finishes | US3, US4, US10, US26, US26D, US28, 313, 315 US32D - 98 ONLY -AM Antimicrobial (available US26D and US32D) | | | | | | | | | | |
| -LHR | Left hand reverse | | | | | | | | | | |
| -RHR | Right hand reverse | | | | | | | | | | |

Standard trim

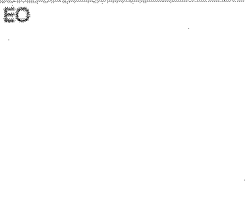
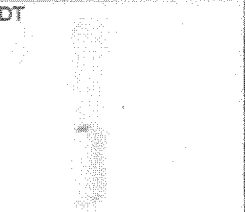
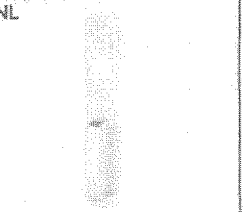
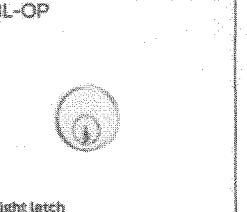
| | EO | DT | NL | NL-OP |
|---------------------------------------|---|--|--|---|
| |  |  |  |  |
| | No outside trim Exit only | Dummy trim Pull when dogged | Night latch Key retracts latchbolt | Night latch Key retracts latchbolt optional pull required |
| Product description | 98EO 99EO | 98DT 99DT | 98NL 99NL | 98NL-OP 99NL-OP |
| Trim description | — | 990DT | 990NL-R/V | 110NL-MD 110NL-WD |
| Escutcheon plate size | — | 3" x 14 ¹⁵ / ₁₆ " x 3 ¹ / ₃₂ " (76x360x2mm) | 3" x 14 ¹⁵ / ₁₆ " x 3 ¹ / ₃₂ " (76x360x2mm) | — |
| Pull center to center | — | 5 ¹ / ₂ " (140mm) | 5 ¹ / ₂ " (140mm) | — |
| Projection | — | 2" (51mm) | 2" (51mm) | — |
| ANSI function | 01 | 02 | 03 | 03 |
| Cylinder type | — | — | Rim | Rim |
| Handing | — | — | — | — |
| Optional trim | x990EO x996EO | x996K-DT x996L-DT x696DT x697DT | x996K-NL x996L-NL x696NL x697NL | |
| Optional #425 SNB quantity for device | 6 | 2 | 2 | 6 |

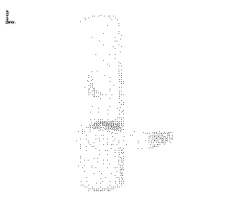
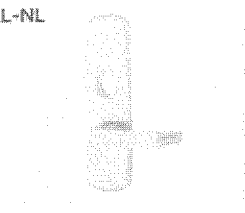
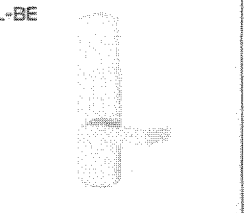
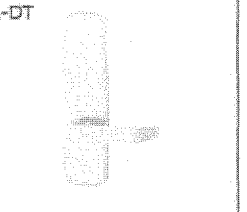
| | L | L-NL | L-BE | L-DT |
|---------------------------------------|--|--|--|--|
| |  |  |  |  |
| | Lever Key locks & unlocks | Lever - night latch Key retracts latchbolt | Lever - blank escutcheon Always operable (no cylinder) | Lever dummy trim pull when dogged |
| Product description | 98L 99L | 98L-NL 99L-NL | 98L-BE 99L-BE | 98L-DT 99L-DT |
| Trim description | 996L-R/V* | 996L-NL-R/V | 996L-BE-R/V* | 996L-DT |
| Escutcheon plate size | 2 ³ / ₄ " x 10 ³ / ₄ " x 2 ¹ / ₃₂ " (70x273x21mm) | 2 ³ / ₄ " x 10 ³ / ₄ " x 2 ¹ / ₃₂ " (70x273x21mm) | 2 ³ / ₄ " x 10 ³ / ₄ " x 2 ¹ / ₃₂ " (70x273x21mm) | 2 ³ / ₄ " x 10 ³ / ₄ " x 2 ¹ / ₃₂ " (70x273x21mm) |
| Pull center to center | — | — | — | — |
| Projection | 2 ¹ / ₈ " (73mm) | 2 ¹ / ₈ " (73mm) | 2 ¹ / ₈ " (73mm) | 2 ¹ / ₈ " (73mm) |
| ANSI function | 08 | 03 | 14 | 02 |
| Cylinder type | Rim | Rim | — | — |
| Handing | Handed/Reversible | Handed/Reversible | Handed/Reversible | Handed/Reversible |
| Optional #425 SNB quantity for device | 2 | 2 | 2 | 2 |

* Electrified lever operation available

Notes

98/99 Dogging options

CDSI/HDSI dogging indicators



Indicator provides an at-a-glance verification of the status of the door from inside of the room. Visible "LOCKED" and "UNLOCKED" indicators show whether the device is undogged or dogged. This feature can be used with Hex key (HDSI) or Cylinder dogging (CDSI) options

on various device types – rim, mortise and vertical systems.

Modular conversion kits allow you to quickly and easily upgrade your existing devices

Available for 98/99 & 33A/35A Series panic devices

To order, specify:

Use prefix, CDSI or HDSI, example CDSI99L

CD Cylinder dogging

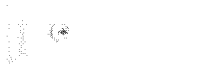

Cylinder dogging is available on all 98/99™ Panic exit devices to replace the standard hex key dogging. Unit requires a standard 1 1/2" (32mm) mortise cylinder with an Inverted straight cam. When ordering, reference Schlage cylinder 20-001, 1 1/2", XQ11-949. This provides the L583-477 cam inverted at the factory.

To order, specify:

Use prefix, CD, example CD99L

CDK Cylinder dogging kit*

For field conversion, a cylinder dogging conversion kit is available.

To order, specify: 99CDK or 98CDK, specify finish.

*Cannot be added to fire exit hardware.

HDK Hex key dogging kit*

For field conversion, a hex key dogging conversion kit is available.

To order, specify: 99HDK or 98HDK, specify finish.

*Cannot be added to fire exit hardware.

LD Less dogging

Less dogging is available in all 98/99™ Panic exit devices to remove the dogging option.

To order, specify: Use prefix LD, example LD99L

Dog keys

Dog key (old style)

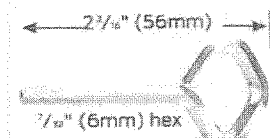

Dog key (standard)

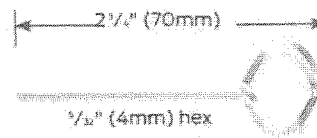

-2SI Double cylinder with security indicator

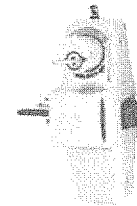

The Von Duprin Classroom Security Indicator provides an at-a-glance verification of the locked/unlocked status of the door from inside of the room. This option can be ordered as a new product or as a retrofit conversion kit to an existing 98/99 device. Indicator in Unlocked state presents a 1/2" x 1/4" metal flag (white background with black icon) at top of device head. Indicator in Locked state has no flag present.

To order, specify:

1. Suffix-2SI with device/trim number, example 99L-2SI.
 2. Handing required, LHR or RHR.
 3. *Specify keyed rim cylinder or thumbturn rim cylinder.
- * Rim cylinder (3216) sold separately. Rim cylinder with thumbturn available from Schlage (part #XB11-979).

Double cylinder



Double cylinder features an inside key cylinder which locks or unlocks the outside trim and an outside key cylinder which retracts the latch bolt only (Night latch function). Available on rim or mortise lock device.

Rim requires two rim type cylinders. Mortise device requires 1 rim cylinder and 1 mortise cylinder 1 1/2" with a straight cam. (Schlage cam reference L583-475.)

Available functions are thumbpiece, knob or lever.

To order, specify:

1. Suffix-2 with device/trim number, example 99TP-2.
2. Handing required, LHR or RHR.

SD Special center case dogging

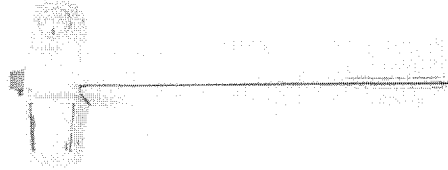

Special cylinder dogging in the center case is available for Chexit, EL, QEL, ALK panic devices to allow for mechanical push/pull operation. With this option, the latchbolt is held retracted and pushbar is still operable. Specify handing—RHR or LHR.

SD requires 1 1/2" (32mm) mortise cylinder with an inverted straight cam. When ordering, reference Schlage cylinder 20-001, 1 1/2", XQ11-949. This provides the L583-477 cam inverted at the factory.

Note: Available on Rim and Vertical Rod Panic Exit Devices only.

To order, specify:

1. Prefix SD, example SD99L and Handing.
2. Not for 98/9975 Devices.

Deadbolt designs

B600 Series

Schlage's toughest heavy duty Grade 1 commercial deadbolt.

Furnished with conventional cylinder standard.

Also available with full size interchangeable core cylinder or small format interchangeable core (SFIC) cylinder.

Requires 2¹/₈" (54mm) prep. UL10B and UL 10C listing standard for auxiliary lock on A label fire doors. Not all functions available as fire rated auxiliary locks. See function charts for required cross bore dimensions.



B700 Series

Same lock as B600 Series but furnished with Primus XP controlled access cylinder for patented key control, geographical exclusivity and resistance to picking and impressioning. Also available with Primus XP full size interchangeable core cylinder.

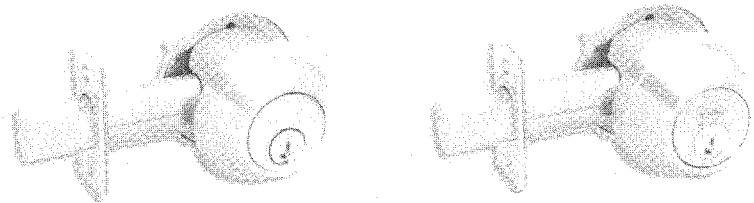

B800 Series

Same lock as B700 Series but Primus XP high security cylinder is UL437 listed to resist drilling and other forms of physical attack. Not available in interchangeable core.

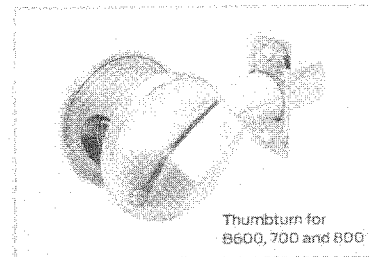
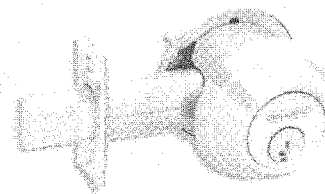

All designs shown in 626 satin chrome

Schlage ANSI
B662P E0141

Cylinder only deadbolt

- Deadbolt thrown or retracted by key on either side

Outside Inside

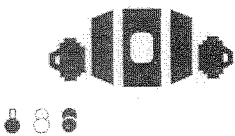

Schlage ANSI
B663P E0171

Classroom deadbolt

- Deadbolt thrown only by key outside.
- Deadbolt retracted by key outside or thumbturn inside

Outside Inside

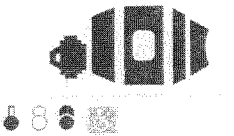

Schlage ANSI
B664P E0101

Cylinder only deadbolt

- Deadbolt thrown or retracted by key one side
- No trim on inside
- 1 1/2" bore only¹

Outside Inside

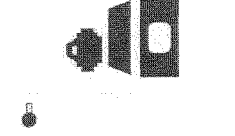

Schlage ANSI
B680 E0191

Trim bolt

- Deadbolt thrown or retracted by thumbturn inside
- No outside trim
- 1 1/2" bore only¹

Outside Inside



Schlage ANSI
B762P E0141

Double cylinder deadbolt

- Deadbolt thrown or retracted by key on either side

Outside Inside

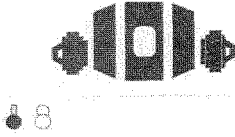

Schlage ANSI
B763P E0171

Classroom deadbolt

- Deadbolt thrown only by key outside
- Deadbolt retracted by key outside or thumbturn inside

Outside Inside

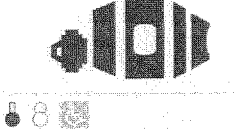

Schlage ANSI
B764P E0101

Cylinder only deadbolt

- Deadbolt thrown or retracted by key one side
- No trim on inside
- 1 1/2" bore only¹

Outside Inside

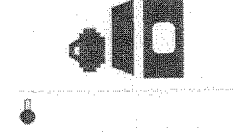

Schlage ANSI
B862P E0141

Double cylinder deadbolt

- Deadbolt thrown or retracted by key on either side

Outside Inside

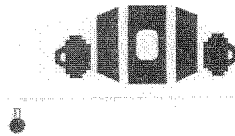

Schlage ANSI
B863P E0171

Classroom deadbolt

- Deadbolt thrown only by key outside
- Deadbolt retracted by key outside or thumbturn inside

Outside Inside



Schlage ANSI
B864P E0101

Cylinder only deadbolt

- Deadbolt thrown or retracted by key one side
- No trim on inside
- 1 1/2" bore only¹

Outside Inside

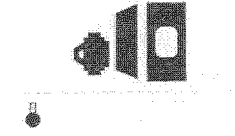

1. See template for details

4040XP SERIES

FEATURES

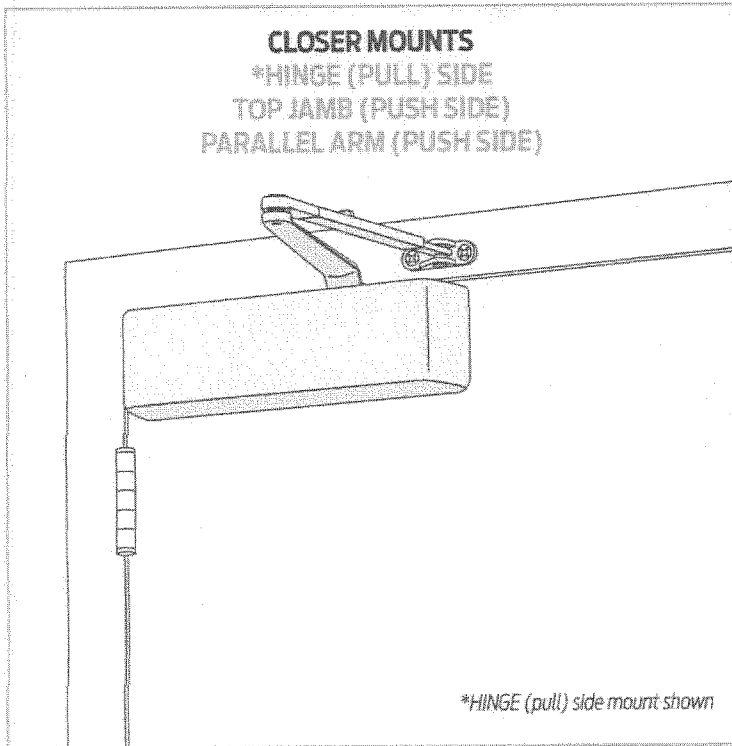

The 4040XP is LCN's most durable and flexible heavy duty closer designed for institutional and other demanding high traffic applications.

- Cast Iron
- Forged Steel Arm
- Double Heat Treated Steel Pinion
- All Weather Fluid
- Non-Handed
- LCN Patented Green Dial
- Peel-n-Stick Templates for Fast and Accurate Installation
- UL & cUL Listed
- 3/4" Journal Diameter Pinion
- Full Compliment Bearing

- Standard 4040XP Series closer shipped with regular arm, standard plastic cover, and self reaming and tapping screws.
- Non-sized cylinder is adjustable for interior doors to 5'0" and exterior doors to 4'0".
- Closer mounts hinge side, top jamb, and parallel arm on either right or left swinging doors.
- Closers to meet ADA requirements.
- Standard or optional custom powder coat finish.
- Optional plated finish on cover, arm, and fasteners.
- Optional SRI primer for installations in corrosive conditions. (Available with powder coat finishes only.)
- UL and cUL listed for self-closing doors without hold-open.
- Tested and certified under ANSI Standard A156.4, grade one.



| MOUNTING | | | | | FINISH | | COVER | | CYLINDER | | | **ARM FUNCTION | | | | | | | | | | | |
|-------------------|-----------------|-----------------|--------------|-----------|-------------|--------|---------|-------|------------|-----------|---------------|--------------------|--------|------------------|-------------------|-----------|-------------|---------|--------------|---------------|--------------|------|---|
| HINGE (PULL) SIDE | TOP JAMB (PULL) | TOP JAMB (PUSH) | PARALLEL ARM | STOP FACE | POWDER COAT | PLATED | PLASTIC | METAL | NON-HANDED | NON-SIZED | ACCESSIBILITY | DELAYED ACTION**** | AVB*** | REGULAR (DOUBLE) | STANDARD (SINGLE) | HOLD-OPEN | PUSHER LINK | EDAMEDA | CUSH/RECUISH | SCUS/SH/SCUSH | DOUBLE FEEDS | | |
| ● | ○ | ● | ● | ○ | ● | ● | ● | ● | ● | ● | ♿ | ● | ○ | 120° | ○ | 120° | ○ | 180° | ○ | 110° | ○ | 110° | ○ |

● AVAILABLE
 ○ NOT AVAILABLE

♿ Closer available with less than 5.0 lbs. opening force on 36" door.
 ** Maximum opening/hold-open point with standard template.
 *** Advanced Variable Backcheck.
 **** Delayed Action Closer incorporates standard 4041 Delay Cylinder.

LCN.

37

PHONE 877-671-7011
 FAX 800-248-1460
 www.allegion.com/us
 2/14

4040XP SERIES

ORDERING INFORMATION

TABLE OF SIZES

4040XP cylinders are adjustable from size 1 through size 6 and is shipped set to size 3.

Closing power of 4040XP Series closers may be adjusted 50%.

EXTERIOR (and VESTIBULE) DOOR WIDTH

| | | | | | |
|---------|--------------------|-------|-------|--------|--------|
| | 24" | 30" | 36" | 42" | 48" |
| | 610mm | 762mm | 914mm | 1067mm | 1219mm |
| *4040XP | | | | | |
| | Minimum Door Width | | | | |

INTERIOR DOOR WIDTH

| | | | | | | |
|---------|--------------------|-------|-------|--------|--------|--------|
| | 24" | 34" | 38" | 48" | 54" | 60" |
| | 610mm | 864mm | 965mm | 1219mm | 1372mm | 1524mm |
| *4040XP | | | | | | |
| | Minimum Door Width | | | | | |

—————> Indicates recommended range of door width for closer size.

*Adjustable Size 1 thru 6.

REDUCED OPENING FORCE 4040XP SERIES CLOSERS

CAUTION! Any manual door closer, including those certified by BHMA to conform to ANSI Standard A156.4, that is selected, installed and adjusted based on ADA or other reduced opening force requirements may not provide sufficient power to reliably close and latch a door.

Refer to POWER OPERATORS section for information on systems that meet reduced opening force requirements without effecting closing power.

| | DOOR WIDTH | 36" | 42" | 48" |
|--|------------|--------|--------|--------|
| | 8.5* lbs. | 4040XP | 4040XP | 4040XP |
| | 5.0* lbs. | 4040XP | 4040XP | 4040XP |

*Maximum opening force.

HOW-TO-ORDER 4040XP SERIES CLOSERS

1. SELECT FINISH

- Standard Powder Coat _____
Aluminum, Dark Bronze, Statuary,
Light Bronze, Black, Brass.

Closer will be shipped with:

- STANDARD CLIP-ON COVER
- SPECIFY ARM WHEN ORDERING
- SELF-REAMING and TAPPING SCREWS,
unless options listed below are selected.

CLOSER OPTIONS

CYLINDER

- Delayed Action (4041 DEL)

COVER

- Metal (specify right or left hand) (MC)

FINISH

- Custom Powder Coat (RAL) _____
(handed metal cover required)
- Plated Finish, US _____
(handed metal cover required)
- SRI primer (use with powder coat finishes only)

ARM

- Regular (REG)
- Regular w/62PA (Rw/PA)
- Regular w/62A (R/62A)
- Long (LONG)
- Extra Long (XLONG)
- Hold-Open (H)
- Hold-Open w/62PA (Hw/PA)
- Long Hold-Open (HLONG)
- Extra Duty Arm (EDA)
- Extra Duty Arm with 62G (EDA/62G)
- Hold Open Extra Duty Arm (HEDA) (Handed)
- Hold Open Extra Duty Arm with 62(HEDA/62G) (Handed)
- Cush-N-Stop (CUSH)
- HCush-N-Stop (HCUSH)
- Spring Cush (SCUSH)
- Spring HCush (SHCUSH)

OPTIONAL SCREW PACKS

- TB* w/Self-Reaming and Tapping (TBSRT)
 - Wood & Machine Screw (WMS)
 - TB*, Wood & Machine Screw (TBWMS)
 - TORX Machine Screw (TORX)
 - TB* & TORX Machine Screw (TBTRX)
- *Specify door thickness if other than 1-3/4".

INSTALLATION ACCESSORIES

- Plate, 4040XP-18
- Plate, 4040XP-18TJ
- Plate, 4040XP-18G
- Plate, 4040XP-18PA
- CUSH Shoe Support, 4040XP-30
- Blade Stop Spacer, 4040XP-61
- Auxiliary Shoe, 4040XP-62A
- PA Flush Panel Adapter, 4040XP-419

SPECIAL TEMPLATE

- ST- _____

PHONE 877-671-7011
FAX 800-248-1460
www.allegion.com/us
4/15 009426

Push Plates - .050" Thick

Material: Aluminum, Brass, Bronze, Stainless Steel

Finishes: Available in standard architectural finishes, US32DB10, US32D316, US32316, and US3LIFETIME (see page 7).

Fastener: #6 x 5/8 OH SMS

Features: Four beveled edges.

Ordering: Specify plate number followed by size designation and finish; i.e., 70B US32D or for non-standard size 70 (width x height) and finish. Specify any additional optional features.

- Options:**
- Custom sizes available upon request.
 - TEK - self-drilling screws.
 - TORX - security torx screws.
 - SA - self-adhesive mounting: 1/16" double face foam tape (no screw holes on plate).
 - Engraving on plates 4" wide or wider. Specify copy. See page B1 for standard engraving locations.
 - Cylinder Cutouts (C/C) and Turn Knob Cutouts (C/TK). See page B1 for standard locations and sizes.



No. 70

| No. | Standard Size | Weight | ANSI A156.6 |
|-----|---------------|----------|-------------|
| 70A | 3" x 12" | 0.7 lbs. | J301 |
| 70B | 3½" x 15" | 0.9 lbs. | J301 |
| 70C | 4" x 16" | 1.0 lbs. | J301 |
| 70E | 6" x 16" | 1.5 lbs. | J301 |
| 70F | 8" x 16" | 2.0 lbs. | J301 |
| 70G | 4" x 20" | 1.3 lbs. | J301 |



No. 70RC

| No. | Standard Size | Weight | ANSI A156.6 |
|-------|---------------|----------|-------------|
| 70RCA | 3" x 12" | 0.7 lbs. | J301 |
| 70RCB | 3½" x 15" | 0.9 lbs. | J301 |
| 70RCC | 4" x 16" | 1.0 lbs. | J301 |
| 70RCE | 6" x 16" | 1.5 lbs. | J301 |
| 70RCF | 8" x 16" | 2.0 lbs. | J301 |
| 70RCG | 4" x 20" | 1.3 lbs. | J301 |



No. 70RE

| No. | Standard Size | Weight | ANSI A156.6 |
|-------|---------------|----------|-------------|
| 70REA | 3" x 12" | 0.7 lbs. | J301 |
| 70REB | 3½" x 15" | 0.9 lbs. | J301 |
| 70REC | 4" x 16" | 1.0 lbs. | J301 |



Door Pulls

No. 102, 105, 106, 107, 108, 109

Material: Aluminum, Brass, Bronze, Stainless Steel

Finishes: Available in standard architectural finishes, US32DB10, US32D316, US32316, white (WPC), red (RPC), and black (BPC) powder coat finishes (see page 7). *US3LIFETIME available on select product below.

Fastener: ¼-20 Thru Bolt and Finish Washer

- Options:**
- Back to back mounting in pairs — use BTB suffix and mounting type number (107BTB5).
 - Concealed mounting single pulls — use C suffix and mounting type number (107C6).
 - Advise if door thickness other than 1¾".
 - See page B13 for mounting selection.
 - 2½" Barrier Free clearance — use BF prefix (BF107).

| No. | Material Size | CTC | Overall | Base | Projection | Clearance | Weight | ANSI A156.6 |
|------|---------------|-----|---------|------|------------|-----------|----------|-------------|
| 102 | ¾" dia. | 5½" | 6½" | ⅝" | 2" | 1⅜" | 0.6 lbs. | — |
| 105 | ¾" dia. | 5½" | 6¼" | ¾" | 2¼" | 1½" | 1.2 lbs. | J401 |
| 106 | ¾" dia. | 6" | 6¾" | ¾" | 2¼" | 1½" | 1.3 lbs. | J401 |
| 107* | ¾" dia. | 8" | 8¾" | ¾" | 2¼" | 1½" | 1.6 lbs. | J401 |
| 108 | ¾" dia. | 10" | 10¾" | ¾" | 2¼" | 1½" | 1.8 lbs. | J401 |
| 109 | ¾" dia. | 12" | 12¾" | ¾" | 2¼" | 1½" | 2.1 lbs. | J401 |

Door Pulls

No. 110, 111A, 111, 112, 118

Material: Aluminum, Brass, Bronze, Stainless Steel

Finishes: Available in standard architectural finishes, US32DB10, US32D316, US32316, white (WPC), red (RPC), and black (BPC) powder coat finishes (see page 7). *US3LIFETIME available on select product below.

Fastener: ¼-20 Thru Bolt and Finish Washer

- Options:**
- Back to back mounting in pairs — use BTB suffix and mounting type number (112BTB5).
 - Concealed mounting single pulls — use C suffix and mounting type number (112C6).
 - Advise if door thickness other than 1¾".
 - Heavy duty versions of most fastening types available — use suffix HD to fastening type number (112BTB5HD).
 - See page B13 for mounting selection.
 - 2½" Barrier Free clearance — use BF prefix (BF110).

| No. | Material Size | CTC | Overall | Base | Projection | Clearance | Weight | ANSI A156.6 |
|------|---------------|-----|---------|------|------------|-----------|----------|-------------|
| 110 | 1" dia. | 8" | 9" | 1" | 3" | 2" | 3.0 lbs. | — |
| 111A | 1" dia. | 9" | 10" | 1" | 3" | 2" | 3.3 lbs. | J401 |
| 111* | 1" dia. | 10" | 11" | 1" | 3" | 2" | 3.5 lbs. | J401 |
| 112* | 1" dia. | 12" | 13" | 1" | 3" | 2" | 4.0 lbs. | J401 |
| 118 | 1" dia. | 18" | 19" | 1" | 3" | 2" | 5.4 lbs. | J401 |

Automatic Flush Bolts

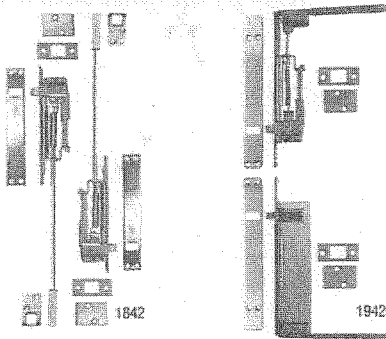

The #1842 is U.L. listed for use on the inactive leaf of a pair of A, B, C, D, and E labeled metal doors. The #1942 is U.L. listed for use on the inactive leaf of a pair of B, C, D, and E labeled wood covered composite doors. The patented non-handed cam triggering device is the heart of this smooth-acting mechanism; only five pounds of force is required to drive a pair of bolts allowing door closing devices to perform at maximum efficiency. An override feature prevents damage to doors or bolts should the bolt heads be prevented from penetrating either the top or bottom strikes. The bolts are adjustable for unusual clearance or conditions and have a thermal lock that automatically locks the inactive door under high heat conditions due to fire.

Combination Flush Bolts

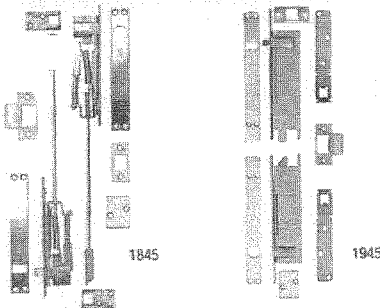

The combination flush bolt uses one automatic flush bolt for the bottom of the door and a constant self-latching flush bolt for the top of the door. When the active leaf is opened, the bottom automatic flush bolt is opened. However the inactive leaf stays latched at the top until it is manually released by depressing the plunger on the bolt face. The top bolt engages each time the inactive door is closed. The #1845 is U.L. listed for use on A, B, C, D, and E labeled metal doors. The #1945 is U.L. listed for use on B, C, D, and E labeled wood covered composite doors. Sold in sets.

Flush and Surface Bolts

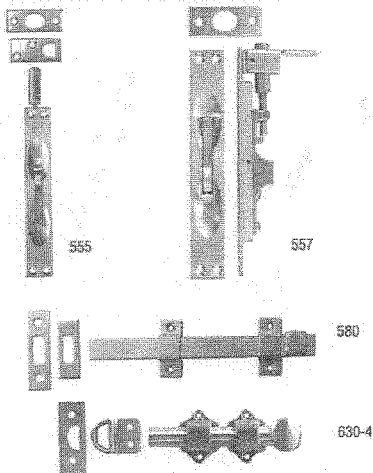

Flush Bolts and Surface Bolts are for use on A, B, C, D, and E labeled metal doors. Standard rod length is 12". Other lengths are available to order.

Flush Bolts — are U.L. listed for all types of labeled wood fire doors. Door strength is maintained by a reinforcing plate. Simple installation instructions are enclosed in each box.

| No. | Size |
|-----|-----------------|
| 550 | 6-3/4" x 1-1/4" |
| 555 | 6-3/4" x 1" |
| 557 | 6-3/4" x 1" |

Surface Bolts — are heavy duty and are U.L. listed for use on the inactive leaf of a pair of labeled fire doors.

| No. | Overall Size |
|--------|-----------------|
| 580 | 8" |
| 630-4 | 1-5/8" x 4-3/8" |
| 630-8 | 1-5/8" x 8" |
| 630-12 | 1-5/8" x 12" |
| 630-24 | 1-5/8" x 24" |

Dust Proof Strike



Dust Proof Strikes are designed to work with any of our flush bolts. Use of these strikes eliminates the problem of floor strikes being clogged with dirt and debris. This combo unit can be used in any situation with or without the removable face plate.

Coordinators

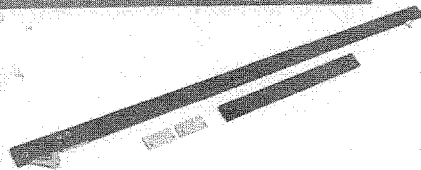

This non-handed coordinator (with companion filler) is designed to become an integral part of the door frame and when painted with the frame becomes virtually invisible. It is engineered to prevent damage in case of abnormal force against the door that is held open. The 1600 series is manufactured in three different housing lengths to coordinate the full range of door sizes.

SECTION 08 8000
GLAZING

PART 1 GENERAL

1.01 SECTION INCLUDES

- A. Insulating glass units.
- B. Glazing units.
- C. Glazing compounds and accessories.

1.02 RELATED REQUIREMENTS

- A. Section 07 2500 - WEATHER BARRIERS.

1.03 REFERENCE STANDARDS

- A. 16 CFR 1201 - Safety Standard for Architectural Glazing Materials.
- B. ANSI Z97.1 - American National Standard for Safety Glazing Materials Used in Buildings, Safety Performance Specifications and Methods of Test.
- C. ASCE 7 - Minimum Design Loads for Buildings and Other Structures.
- D. ASTM C864 - Standard Specification for Dense Elastomeric Compression Seal Gaskets, Setting Blocks, and Spacers.
- E. ASTM C920 - Standard Specification for Elastomeric Joint Sealants.
- F. ASTM C1048 - Standard Specification for Heat-Strengthened and Fully Tempered Flat Glass.
- G. ASTM C1172 - Standard Specification for Laminated Architectural Flat Glass.
- H. ASTM C1193 - Standard Guide for Use of Joint Sealants.
- I. ASTM C1376 - Standard Specification for Pyrolytic and Vacuum Deposition Coatings on Flat Glass.
- J. ASTM E1300 - Standard Practice for Determining Load Resistance of Glass in Buildings.
- K. ASTM E2190 - Standard Specification for Insulating Glass Unit Performance and Evaluation.
- L. California Code of Regulations, Title 24, Part 11 California Green Building Standards Code, "CAL-Green".
- M. California Code of Regulations, Title 24, Part 2, California Building Code (CBC), International Building Code with California Amendments.
- N. GANA (GM) - GANA Glazing Manual.
- O. GANA (SM) - GANA Sealant Manual.
- P. GANA (LGRM) - Laminated Glazing Reference Manual.
- Q. IGMA TM-3000 - North American Glazing Guidelines for Sealed Insulating Glass Units for Commercial & Residential Use.
- R. ITS (DIR) - Directory of Listed Products.
- S. NFRC 100 - Procedure for Determining Fenestration Product U-factors.

- T. NFRC 200 - Procedure for Determining Fenestration Product Solar Heat Gain Coefficient and Visible Transmittance at Normal Incidence.
- U. NFRC 300 - Test Method for Determining the Solar Optical Properties of Glazing Materials and Systems.
- V. UL (DIR) - Online Certifications Directory.

1.04 DEFINITIONS

- A. Manufacturers of Glass Products: Firms that produce primary glass, fabricated glass, or both, as defined in referenced glazing publications.
- B. Glass Thicknesses: Indicated by thickness designations in millimeters according to ASTM C 1036.
- C. Interspace: Space between lites of an insulating-glass unit that contains dehydrated air or a specified gas.
- D. Deterioration of Coated Glass: Defects developed from normal use that are attributed to the manufacturing process and not to causes other than glass breakage and practices for maintaining and cleaning coated glass contrary to manufacturer's written instructions. Defects include peeling, cracking, and other indications of deterioration in metallic coating.
- E. Deterioration of Insulating Glass: Failure of hermetic seal under normal use that is attributed to the manufacturing process and not to causes other than glass breakage and practices for maintaining and cleaning insulating glass contrary to manufacturer's written instructions. Evidence of failure is the obstruction of vision by dust, moisture, or film on interior surfaces of glass.
- F. Deterioration of Laminated Glass: Defects developed from normal use that are attributed to the manufacturing process and not to causes other than glass breakage and practices for maintaining and cleaning laminated glass contrary to manufacturer's written instructions. Defects include edge separation, delamination materially obstructing vision through glass, and blemishes exceeding those allowed by referenced laminated-glass standard.
- G. Glazing Units Surfaces:
 - 1. Insulated units:
 - a. Side 1 - Exterior surface of outer pane.
 - b. Side 2 - Interior surface of outer pane.
 - c. Side 3 - Interior surface of inner pane.
 - d. Side 4 - Exterior surface of inner pane
 - 2. Laminated units:
 - a. Side 1 - Top surface of top outer pane in horizontal orientation.
 - b. Interlayer: PVB material between two pieces of monolithic glass
 - c. Side 2 - Underside of bottom outer pane in horizontal orientation.

1.05 SUBMITTALS

- A. See Section 01 3300 - Administrative Requirements, for submittal procedures.
- B. Product Data on Insulating Glass Unit and Glazing Unit Glazing Types: Provide structural, physical and environmental characteristics, size limitations, special handling and installation requirements.
- C. Product Data on Glazing Compounds and Accessories: Provide chemical, functional, and environmental characteristics, limitations, special application requirements. Identify available colors.
- D. CAL-GREEN Submittals:
 - 1. Product Data - VOC Limits: For adhesives sealants, fillers and primers, documentation including printed statement of VOC contents, comply with limits specified in Section 01 6116.

- E. Samples: Submit two samples 12 by 12 inch in size of glass units.
- F. Samples: Submit 2 inch long bead of glazing sealant, color as selected.
- G. Certificate: Certify that products of this section meet or exceed specified requirements.
- H. Warranty Documentation: Submit manufacturer warranty and ensure that forms have been completed in Owner's name and registered with manufacturer.
- I. Maintenance Materials: Furnish the following for Owner's use in maintenance of project.
 - 1. See Section 01 6000 - Product Requirements, for additional provisions.
 - 2. Extra Insulating Glass Units: One of each glass size and each glass type.

1.06 QUALITY ASSURANCE

- A. Perform Work in accordance with GANA (GM), GANA (SM), GANA (LGRM), and IGMA TM-3000 for glazing installation methods. Maintain one copy on site.
- B. Installer Qualifications: An experienced installer who has completed glazing similar in material, design, and extent to that indicated for this Project; whose work has resulted in glass installations with a record of successful in-service performance; and who employs glass installers for this Project who are certified under the National Glass Association Glazier Certification Program as Level 2 (Senior Glaziers) or Level 3 (Master Glaziers).
- C. Glass Product Testing: Obtain glass test results for product test reports in "Submittals" Article from a qualified testing agency based on testing glass products.
 - 1. Glass Testing Agency Qualifications: An independent testing agency with the experience and capability to conduct the testing indicated, as documented according to ASTM E 548.
- D. Elastomeric Glazing Sealant Product Testing: Obtain sealant test results for product test reports in "Submittals" Article from a qualified testing agency based on testing current sealant formulations within a 36-month period.
 - 1. Sealant Testing Agency Qualifications: An independent testing agency qualified according to ASTM C 1021 to conduct the testing indicated, as documented according to ASTM E 548.
 - 2. Test elastomeric glazing sealants for compliance with requirements specified by reference to ASTM C 920, and where applicable, to other standard test methods.
- E. Glazing for Fire-Rated Door Assemblies: Glazing for assemblies that comply with NFPA 80 and that are listed and labeled by a testing and inspecting agency acceptable to authorities having jurisdiction, for fire-protection ratings indicated, based on testing according to NFPA 252.
- F. Glazing for Fire-Rated Window Assemblies: Glazing for assemblies that comply with NFPA 80 and that are listed and labeled by a testing and inspecting agency acceptable to authorities having jurisdiction, for fire ratings indicated, based on testing according to NFPA 257.
- G. Safety Glazing Products: Comply with testing requirements in 16 CFR 1201 .
 - 1. Provide safety glazing products permanently marked with certification label of the Safety Glazing Certification Council (SGCC) <<http://www.sgcc.org/>> or another certification agency acceptable to authorities having jurisdiction.
 - 2. Where glazing units, including Kind FT glass and laminated glass, are specified in Part 2 articles for glazing lites, provide glazing products that comply with Category II materials only.
- H. Insulating-Glass Certification Program: Permanently marked either on spacers or on at least one component lite of units with appropriate certification label of the following testing and inspecting agency:
 - 1. Insulating Glass Certification Council.
 - 2. Associated Laboratories, Inc.

- I. Source Limitations for Glass: Provide materials produced by a single manufacturer or fabricator for each kind and condition of glass indicated and composed of primary glass obtained from a single source for each type and class required.
- J. Source Limitations for Glazing Accessories: Obtain glazing accessories through one source from a single manufacturer for each product and installation method indicated.

1.07 FIELD CONDITIONS

- A. Do not install glazing when ambient temperature is less than 40 degrees F.
- B. Maintain minimum ambient temperature before, during and 24 hours after installation of glazing compounds.

1.08 WARRANTY

- A. See Section 01 7800 - Closeout Submittals, for additional warranty requirements.
- B. Insulating Glass Units: Provide a ten (10) year manufacturer warranty to include coverage for seal failure, interpane dusting or misting, including replacement of failed units.
- C. Laminated Glass: Provide a ten (10) year manufacturer warranty to include coverage for delamination, including replacement of failed units.
- D. Manufacturer's Special Warranty for Coated-Glass Products: Manufacturer's standard form, made out to Owner and signed by coated-glass manufacturer agreeing to replace coated-glass units that deteriorate as defined in "Definitions" Article, f.o.b. the nearest shipping point to Project site, within specified warranty period indicated below.
 - 1. Warranty Period: Ten (10) years from date of Substantial Completion.

PART 2 PRODUCTS

2.01 MANUFACTURERS

- A. Float Glass Manufacturers:
 - 1. Guardian Glass, LLC: www.guardianglass.com/#sle.
 - 2. Pilkington North America Inc: www.pilkington.com/na/#sle.
 - 3. PPG Industries, Inc: www.ppgideascales.com/#sle.
 - 4. Substitutions: Refer to Section 01 6000 - Product Requirements.
- B. Fire-Resistance-Rated Glass: Provide products as required to achieve indicated fire-rating period.
 - 1. SAFTIFIRST, a division of O'Keeffe's Inc; SuperLite II-XL: www.safti.com/#sle.
 - 2. Technical Glass Products; Pilkington Pyrostop: www.fireglass.com/#sle.
 - 3. Vetrotech North America; Contraflam: www.vetrotechusa.com/#sle.
 - 4. Substitutions: Refer to Section 01 6000 - Product Requirements.

2.02 PERFORMANCE REQUIREMENTS - EXTERIOR GLAZING ASSEMBLIES

- A. General: Provide glazing systems capable of withstanding normal thermal movement and wind and impact loads (where applicable) without failure, including loss or glass breakage attributable to the following: defective manufacture, fabrication, and installation; failure of sealants or gaskets to remain watertight and airtight; deterioration of glazing materials; or other defects in construction.
- B. VOC Limits for all adhesives sealants, fillers, primers and coatings: Comply with limits specified in Section 01 6116.
- C. Glass Design: Glass thickness designations indicated are minimums and are for detailing only. Confirm glass thicknesses by analyzing Project loads and in-service conditions. Provide glass lites in

the thickness designations indicated for various size openings, but not less than thicknesses and in strengths (annealed or heat treated) required to meet or exceed the following criteria.

- D. Provide type and thickness of exterior glazing assemblies to support assembly dead loads, and to withstand live loads caused by positive and negative wind pressure acting normal to plane of glass.
 - 1. Specified Design Wind Loads: As indicated on structural drawings, but not less than wind loads applicable to Project as required by ASCE 7 "Minimum Design Loads for Buildings and Other Structures": Section 6.0 "Wind Loads."
 - 2. Comply with ASTM E1300 for design load resistance of glass type, thickness, dimensions, and maximum lateral deflection of supported glass.
 - 3. Probability of Breakage for Vertical Glazing: 8 lites per 1000 for lites set vertically or not more than 15 degrees off vertical and under wind action.
 - a. Load Duration: 3 seconds.
 - 4. Seismic Loads: Design and size glazing components to withstand seismic loads and sway displacement in accordance with the requirements of ASCE 7.
 - 5. Provide glass edge support system sufficiently stiff to limit the lateral deflection of supported glass edges to less than 1/175 of their lengths under specified design load.
 - 6. Glass thicknesses listed are minimum.
- E. Vapor Retarder and Air Barrier Seals: Provide completed assemblies that maintain continuity of building enclosure vapor retarder and air barrier.
 - 1. In conjunction with vapor retarder and joint sealer materials described in other sections.
 - a. Refer to Section 07 2500.
 - 2. To utilize the inner pane of multiple pane insulating glass units for the continuity of the vapor retarder and air barrier seal.
 - 3. To maintain a continuous vapor retarder and air barrier throughout the glazed assembly from glass pane to heel bead of glazing sealant.
- F. Thermal Movements: Provide glazing that allows for thermal movements resulting from the following maximum change (range) in ambient and surface temperatures acting on glass framing members and glazing components. Base engineering calculation on surface temperatures of materials due to both solar heat gain and nighttime-sky heat loss.
 - 1. Temperature Change (Range): 120 deg F (67 deg C), ambient; 180 deg F (100 deg C), material surfaces.
- G. Thermal and Optical Performance: Provide glass products with performance properties as indicated. Performance properties are in accordance with manufacturer's published data as determined with the following procedures and/or test methods:
 - 1. Center of Glass U-Value: Comply with NFRC 100 using Lawrence Berkeley National Laboratory (LBNL) WINDOW 6.3 computer program.
 - 2. Center of Glass Solar Heat Gain Coefficient (SHGC): Comply with NFRC 200 using Lawrence Berkeley National Laboratory (LBNL) WINDOW 6.3 computer program.
 - 3. Solar Optical Properties: Comply with NFRC 300 test method.
- H. Provide Kind FT (fully tempered) glass lites or laminated glass in all locations.

2.03 GLASS MATERIALS

- A. Float Glass: Provide float glass based glazing unless noted otherwise.
 - 1. Heat-Strengthened and Fully Tempered Types: ASTM C1048, Kind HS and FT.
 - 2. Fully Tempered Safety Glass: Complies with ANSI Z97.1 and 16 CFR 1201 criteria.
- B. Laminated Glass: Float glass laminated in accordance with ASTM C1172.
 - 1. Laminated Safety Glass: Complies with ANSI Z97.1 and 16 CFR 1201 test requirements for Category II.

2. Polyvinyl Butyral (PVB) Interlayer: 0.060 inch thick, minimum.
- C. Sputter-Coated Float Glass: ASTM C 1376, float glass with metallic-oxide or -nitride coating deposited by vacuum deposition process after manufacture and heat treatment (if any), and complying with other requirements specified.
 1. Approved Manufacturers:
 - a. "Solarban 60 Solar Control Low-E Glass"; PPG Industries <<http://corporateportal.ppg.com>>(800-377-5267)
 - b. "Comfort Ti-AC-40"; AGC Flat Glass North America <<http://www.afgglass.com>> (800-251-0441)
 - c. "Sunguard SN-68"; Guardian Industries <<http://www.guardian.com>> (248-340-1800)
 - d. "Solarscreen 2000 - VE1-2M"; Viracon, Inc. <<http://www.viracon.com/index.php>> (800-533-2080)

2.04 INSULATING GLASS UNITS

- A. Manufacturers:
 1. Any of the manufacturers specified for float glass.
 2. Fabricator certified by glass manufacturer for type of glass, coating, and treatment involved and capable of providing specified warranty.
 3. Guardian Glass, LLC: www.guardianglass.com/#sle.
 4. Pilkington North America Inc: www.pilkington.com/na/#sle.Pilkington North America Inc: www.pilkington.com/na/#sle.
 5. Viracon, Apogee Enterprises, Inc: www.viracon.com/#sle.
 6. PPG Industries, Inc: www.ppgideascales.com/#sle.
 7. SAFTIFIRST, a division of O'Keeffe's Inc; SuperLite II-XL: www.safti.com/#sle.
 8. Substitutions: Refer to Section 01 6000 - Product Requirements.
- B. Insulating Glass Units: Types as indicated.
 1. Durability: Certified by an independent testing agency to comply with ASTM E2190.
 2. Coated Glass: Comply with requirements of ASTM C1376 for pyrolytic (hard-coat) or magnetic sputter vapor deposition (soft-coat) type coatings on flat glass; coated vision glass, Kind CV; coated overhead glass, Kind CO; or coated spandrel glass, Kind CS.
 3. Metal Edge Spacers: Aluminum, bent and soldered corners.
 4. Spacer Color: Black.
 5. Edge Seal:
 6. Color: Black.
 7. Purge interpane space with dry air, hermetically sealed.
- C. Type Clear - Sealed Insulating Glass Units: Vision glazing, low-E.
 1. Application: All exterior glazing unless otherwise indicated.
 2. Substitutions: Refer to Section 01 6000 - Product Requirements.
 - a. Other products of the basis of design manufacturer and products of other manufacturers will be considered provided the overall performance is within the specified range(s) and the overall appearance is not significantly different from that of the specified product.
 - b. Architect's decision on substitutions is final.
 3. Between-lite space filled with air.
 4. Thermal Resistance (U-Value): 0.29, maximum.
 5. Total Solar Heat Gain Coefficient: 0.27, maximum.
 6. Total Visible Light Transmittance: 0.64 percent, minimum.
 7. Basis of Design: PPG Industries, Inc: www.ppgideascales.com.
 8. Outboard Lite: Fully tempered float glass, 1/4 inch thick, minimum.
 - a. Coating: PPG Solarban 70XL on #2 surface, no coating on #3 surface.

- b. Tint: None (clear).
 - 9. Inboard Lite: Fully tempered float glass, 1/4 inch thick.
 - a. Tint: None (clear).
 - 10. Total Thickness: 1 inch.
- D. Type IG-5 - Insulating Glass Units: Safety glazing.
- 1. Applications:
 - a. Glazed lites in exterior doors.
 - b. Other locations required by applicable federal, state, and local codes and regulations.
 - 2. Space between lites filled with air.
 - 3. Glass Type: Same as other vision glazing except use fully tempered float glass for both outboard and inboard lites.
 - 4. Total Thickness: 1 inch.

2.05 GLAZING UNITS

- A. Type G-1 - Monolithic Exterior Vision Glazing:
- 1. Applications: Exterior glazing unless otherwise indicated.
 - 2. Glass Type: Fully tempered float glass.
 - 3. Tint: Clear.
 - 4. Thickness: 1/4 inch, nominal.
- B. Type G-3 - Fire-Resistance-Rated Glazing: Type, thickness, and configuration of glazing that contains flame, smoke, and blocks radiant heat, as required to achieve indicated fire-rating period exceeding 45 minutes.
- 1. Applications:
 - 2. Provide products listed by ITS (DIR) or UL (DIR) and approved by authorities having jurisdiction.
 - 3. Safety Glazing Certification: 16 CFR 1201 Category II.
 - 4. Fire-Rating Period: 60 minutes.

2.06 GLAZING COMPOUNDS

- A. Butyl Sealant: Single component; ASTM C920, Grade NS, Class 12-1/2, Uses M and A, Shore A hardness of 10 to 20; black color.
- B. Silicone Sealant: Single component; neutral curing; capable of water immersion without loss of properties; non-bleeding, non-staining; ASTM C920, Type S, Grade NS, Class 25, Uses M, A, and G; with cured Shore A hardness range of 15 to 25; black color.

2.07 ACCESSORIES

- A. Setting Blocks: Silicone, with 80 to 90 Shore A durometer hardness; ASTM C864 Option II. Length of 0.1 inch for each square foot of glazing or minimum 4 inch x width of glazing rabbet space minus 1/16 inch x height to suit glazing method and pane weight and area.
- B. Spacer Shims: Neoprene, 50 to 60 Shore A durometer hardness; ASTM C864 Option II. Continuous x one half the height of the glazing stop x thickness to suit application, self adhesive on one face.
- C. Glazing Tape, Back Bedding Mastic Type: Preformed, butyl-based, 100 percent solids compound with integral resilient spacer rod applicable to application indicated; 5 to 30 cured Shore A durometer hardness; coiled on release paper; black color.
- 1. Width: As required for application.
 - 2. Thickness: As required for application.
 - 3. Spacer Rod Diameter: As required for application.
 - 4. Manufacturers:

- a. Pecora Corporation: www.pecora.com/#sle.
 - b. Substitutions: Refer to Section 01 6000 - Product Requirements.
- D. Glazing Splines: Resilient silicone extruded shape to suit glazing channel retaining slot; ASTM C864 Option II; color black.

2.08 SOURCE QUALITY CONTROL

- A. Provide shop inspection and testing for insulated glass.

PART 3 EXECUTION

3.01 VERIFICATION OF CONDITIONS

- A. Verify that openings for glazing are correctly sized and within tolerances, including those for size, squareness, and offsets at corners.
- B. Verify that the minimum required face and edge clearances are being provided.
- C. Verify that surfaces of glazing channels or recesses are clean, free of obstructions that may impede moisture movement, weeps are clear, and support framing is ready to receive glazing system.
- D. Verify that sealing between joints of glass framing members has been completed effectively.
- E. Glass Product:
 1. Verify that each piece of glass is free of scratches or marred surfaces.
 2. Verify that all edges are clean cut and finished in the specified manner.
- F. Obtain installers written report listing conditions detrimental to performance of glazing work. Proceed with glazing system installation only after unsatisfactory conditions have been corrected.

3.02 PREPARATION

- A. Clean contact surfaces with appropriate solvent and wipe dry within maximum of 24 hours before glazing. Remove coatings that are not tightly bonded to substrates.
- B. Seal porous glazing channels or recesses with substrate compatible primer or sealer.
- C. Prime surfaces scheduled to receive sealant where required for proper sealant adhesion.

3.03 INSTALLATION, GENERAL

- A. Install glazing in compliance with written instructions of glass, gaskets, and other glazing material manufacturers, unless more stringent requirements are indicated, including those in glazing referenced standards.
- B. Install glazing sealants in accordance with ASTM C1193, GANA (SM), and manufacturer's instructions.
- C. Do not exceed edge pressures around perimeter of glass lites as stipulated by glass manufacturer.
- D. Protect glass from edge damage during handling and installation. Inspect glass during installation and discard pieces with edge damage that could affect glass performance.
 1. Use a rolling block in rotating glass units to prevent damage to glass corners.
 2. Do not impact glass with metal framing.
 3. Use suction cups to shift glass units within openings; do not raise or drift glass with a pry bar.
 4. Rotate glass with flares or bevels along one horizontal edge which would occur in vicinity of setting blocks so that these are located at top of opening.
 5. Discard glass units with edge damage or other imperfections of kind that, when installed, weakens glass and impairs performance and appearance.

- E. Provide spacers for glass lites where length plus width is larger than 50 -inches (1270 mm) as follows:
 - 1. Locate spacers directly opposite each other on both inside and outside faces of glass. Install correct size and spacing to preserve required face clearances, unless gaskets and glazing tapes are used that have demonstrated ability to maintain required face clearances and to comply with system performance requirements.
 - 2. Provide 1/8-inch (3-mm) minimum bite of spacers on glass and use thickness equal to sealant width. With glazing tape, use thickness slightly less than final compressed thickness of tape.
- F. Set glass lites of system with uniform pattern, draw, bow, and similar characteristics.
- G. Set glass lites in proper orientation so that coatings face exterior or interior as indicated.
- H. Provide edge blocking where indicated or needed to prevent glass lites from moving sideways in glazing channel, as recommended in writing by glass manufacturer and according to requirements in referenced glazing publications.
- I. Install so that appropriate rating agency markings remain permanently visible.
- J. Prevent glass from contact with any contaminating substances that may be the result of construction operations such as, and not limited to the following; weld splatter, fire-safing, plastering, mortar droppings, etc.

3.04 INSTALLATION - WET/DRY GLAZING METHOD (PREFORMED TAPE AND SEALANT)

- A. Application - Exterior Glazed: Set glazing infills from the exterior of the building.
- B. Cut glazing tape to length and set against permanent stops, 3/16 inch below sight line. Seal corners by butting tape and dabbing with butyl sealant.
- C. Apply heel bead of butyl sealant along intersection of permanent stop with frame ensuring full perimeter seal between glass and frame to complete the continuity of the air and vapor seal.
- D. Place setting blocks at 1/4 points with edge block no more than 6 inch from corners.
- E. Rest glazing on setting blocks and push against tape and heel bead of sealant with sufficient pressure to attain full contact at perimeter of pane or glass unit.
- F. Install removable stops, with spacer strips inserted between glazing and applied stops 1/4 inch below sight lines.
 - 1. Place glazing tape on glazing pane of unit with tape flush with sight line.
- G. Fill gap between glazing and stop with silicone type sealant to depth equal to bite of frame on glazing, but not more than 3/8 inch below sight line.
- H. Apply cap bead of silicone type sealant along void between the stop and the glazing, to uniform line, flush with sight line. Tool or wipe sealant surface smooth.

3.05 INSTALLATION - WET/DRY GLAZING METHOD (TAPE AND SEALANT)

- A. Application - Interior Glazed: Set glazing infills from the interior of the building.
- B. Cut glazing tape to length and install against permanent stops, projecting 1/16 inch above sight line.
- C. Place setting blocks at 1/4 points with edge block no more than 6 inch from corners.
- D. Rest glazing on setting blocks and push against tape to ensure full contact at perimeter of pane or unit.
- E. Install removable stops, spacer shims inserted between glazing and applied stops at 24 inch intervals, 1/4 inch below sight line.

- F. Fill gaps between pane and applied stop with silicone type sealant to depth equal to bite on glazing, to uniform and level line.
- G. Carefully trim protruding tape with knife.

3.06 TOLERANCES

- A. Erection Tolerances: Install components plumb, level, accurately aligned, and located in reference to column lines and floor levels. Erection tolerances indicated below are the maximum allowable for both no-load and full-load conditions and are not cumulative. Adjust work to conform to the following tolerances:
 - 1. Plumb: 1/8 -inch in 10 -feet; 1/4 -inch in 40 -feet.
 - 2. Level: 1/8 -inch in 20 -feet; 1/4 -inch in 40 -feet.
 - 3. Alignment: Limit offset of member alignment to 1/16 -inch where surfaces are flush or less than 1/2 -inch out of flush and separated by less than 3 -inches by protruding work; otherwise limit offsets to 1/8 inch.

3.07 FIELD QUALITY CONTROL

- A. Glass and Glazing product manufacturers to provide field surveillance of the installation of their products.
- B. Monitor and report installation procedures and unacceptable conditions.

3.08 CLEANING

- A. Remove excess glazing materials from finish surfaces immediately after application using solvents or cleaners recommended by manufacturers.
- B. Remove non-permanent labels immediately after glazing installation is complete.
- C. Clean glass and adjacent surfaces after sealants are fully cured.
- D. Clean glass on both exposed surfaces not more than 4 days prior to Date of Substantial Completion in accordance with glass manufacturer's written recommendations.

3.09 PROTECTION

- A. After installation, mark pane with an 'X' by using removable plastic tape or paste; do not mark heat absorbing or reflective glass units.
- B. Examine glass surfaces adjacent to or below exterior concrete and other masonry surfaces at frequent intervals during construction, but not less often than once a month, for build-up of dirt, scum, alkali deposits or staining. When examination reveals presence of these forms of residue, remove by method recommended by glass manufacturer.
- C. Remove and replace glass that is damaged during construction period prior to Date of Substantial Completion.

END OF SECTION

SECTION 08 8300
MIRRORS

PART 1 GENERAL

1.01 SECTION INCLUDES

- A. Custom-Built and Site-Fabricated Glass Mirror Systems.
 - 1. Tempered safety glass.

1.02 RELATED SECTIONS

- A. Section 06 2000 - Finish Carpentry: Wood mirror frames.
- B. Section 10 2800 Toilet, Bath, and Laundry Accessories: Manufactured mirror units.

1.03 REFERENCE STANDARDS

- A. ANSI Z97.1 - American National Standard for Safety Glazing Materials Used in Buildings, Safety Performance Specifications and Methods of Test.
- B. ASTM C920 - Standard Specification for Elastomeric Joint Sealants.
- C. ASTM C1036 - Standard Specification for Flat Glass.
- D. ASTM C1048 - Standard Specification for Heat-Strengthened and Fully Tempered Flat Glass.
- E. ASTM C1193 - Standard Guide for Use of Joint Sealants.
- F. GANA (GM) - GANA Glazing Manual.
- G. GANA (SM) - GANA Sealant Manual.
- H. GANA (TIPS) - Mirrors: Handle with Extreme Care (Tips for the Professional on the Care and Handling of Mirrors).

1.04 SUBMITTALS

- A. See Section 01 3300 - Submittals for submittal procedures.
- B. Product Data on Mirror Types: Submit structural, physical and environmental characteristics, size limitations, special handling and installation requirements.
- C. Product Data on Glazing Compounds: Submit chemical, functional, and environmental characteristics, limitations, special application requirements, and identify available colors.
- D. Samples: Submit two 12 inch x 12 inch in size, illustrating mirrors, coloration, design.
- E. Manufacturer's Certificate: Certify that mirrors, meets or exceeds specified requirements.
- F. Warranty: Submit manufacturer warranty and ensure that forms have been completed in Owner's name and registered with manufacturer.

1.05 QUALITY ASSURANCE

- A. Perform Work in accordance with GANA Glazing Manual for glazing installation methods.
- B. Fabricate, store, transport, receive, install, and clean mirrors in accordance with recommendations of GANA (TIPS).

1.06 WARRANTY

- A. See Section 01 7000 - Contract Closeout for additional warranty submittal requirements.

- B. Provide five year manufacturer warranty for reflective coating on mirrors and replacement of same.

PART 2 PRODUCTS

2.01 MANUFACTURERS

- A. Mirrors:
 - 1. Guardian Industries: www.guardian.com
 - 2. Binswanger Mirror/ACI Distribution; ____: www.binswangerglass.com/#sle.
 - 3. Lenoir Mirror Co; ____: www.lenoirmirror.com/#sle.

2.02 MATERIALS

- A. Mirror Design Criteria: Select materials and/or provide supports as required to limit mirror material deflection to 1/200, or to the flexure limit of glass, with full recovery of glazing materials, whichever is less.
- B. Mirror Glass: Clear, tempered safety glass; ASTM C1048, with copper and silver coatings, and protective overcoating.
 - 1. Thickness: 1/4 inch.
 - 2. Size: As scheduled.

2.03 GLAZING COMPOUNDS

- A. Silicone Sealant; Type ____: ASTM C920, Type S, Grade NS, Class 25, Uses M and A; single component; chemical or solvent curing; non-bleeding, non-staining, cured Shore A hardness of 15 to 25; ____ color.

2.04 ACCESSORIES

- A. Mirror Attachment Accessories: Set mirrors in aluminum mirror-mount cleat and perimeter frame system. CRL Mirror Mount System Cleat, Top Channel Cap and FHA J-Bars by C.R. Laurence Company; www.crlaurence.com, or equal. Anchor rigidly to wall construction.
- B. Mirror Adhesive: Chemically compatible with mirror coating and wall substrate.

PART 3 EXECUTION

3.01 EXAMINATION

- A. Verify that openings for mirrored glazing are correctly sized and within tolerance.
- B. Verify that surfaces of mirror frames or recesses are clean, free of obstructions, and ready for installation of mirrors.

3.02 PREPARATION

- A. Clean contact surfaces with solvent and wipe dry.
- B. Seal porous mirror frames or recesses with substrate compatible primer or sealer. Prime surfaces scheduled to receive sealant.

3.03 INSTALLATION

- A. Install mirrors in accordance with GANA (TIPS) and manufacturers recommendations.
- B. Set mirrors plumb and level, with tempered glass roll wave distortion running in the horizontal direction.
- C. Set mirrors with edge clearance free of surrounding construction including countertops or backsplashes.

- D. Installation in Frames: Set mirrors in perimeter frame system top, bottom and outside edges of mirror array. Interior edges of mirror array shall be set butt edge to butt edge. Anchor frame system rigidly to wall construction.
- E. Frameless Mirrors: Set mirrors in proper place with adhesive, applied in accordance with adhesive manufacturer's instructions.

3.04 CLEANING

- A. Remove wet glazing materials from finish surfaces.
- B. Remove labels after work is complete.
- C. Clean mirrors and adjacent surfaces.

3.05 PROTECTION

- A. After installation, mark pane with an 'X' by using removable plastic tape or paste.

END OF SECTION

SECTION 08 9100

LOUVERS

PART 1 GENERAL

1.01 SECTION INCLUDES

- A. Section specifies shop fabricated and manufactured metal louvers and vents which are not an integral part of the mechanical system. Metal mesh screens are also specified.

1.02 RELATED REQUIREMENTS

- A. Section 07 9200 - Joint Sealants: Sealing joints between frames and adjacent construction.
- B. Section 09 9113 - Exterior Painting: Field painting.
- C. Pertinent sections of Division 23 specifying ductwork, mechanical registers, and mechanical systems connecting to louvers.

1.03 REFERENCE STANDARDS

- A. AAMA 611 - Voluntary Specification for Anodized Architectural Aluminum.
- B. AAMA 2604 - Voluntary Specification, Performance Requirements and Test Procedures for High Performance Organic Coatings on Aluminum Extrusions and Panels.
- C. AMCA 500-L - Laboratory Methods of Testing Louvers for Rating.
- D. AMCA 511 - Certified Ratings Program for Air Control Devices.
- E. ASTM A653/A653M - Standard Specification for Steel Sheet, Zinc-Coated (Galvanized) or Zinc-Iron Alloy-Coated (Galvannealed) by the Hot-Dip Process.
- F. ASTM B209 - Standard Specification for Aluminum and Aluminum-Alloy Sheet and Plate.
- G. ASTM B221 - Standard Specification for Aluminum and Aluminum-Alloy Extruded Bars, Rods, Wire, Profiles, and Tubes.

1.04 SUBMITTALS

- A. See Section 01 3300 - Submittals for submittal procedures.
- B. Product Data: Provide data describing design characteristics, maximum recommended air velocity, design free area, materials and finishes.
- C. Shop Drawings: Indicate louver layout plan and elevations, opening and clearance dimensions, tolerances; head, jamb and sill details; blade configuration, screens, blankout areas required, and frames.
- D. Samples: Submit two samples 2 by 2 inches in size illustrating finish and color of exterior and interior surfaces.
- E. Test Reports: Independent agency reports showing compliance with specified performance criteria.
- F. Manufacturer's Certificate: Certify that products meet or exceed specified requirements.

1.05 QUALITY ASSURANCE

- A. Manufacturer Qualifications: Company specializing in manufacturing products of the type specified in this section, with minimum three years of documented experience.

1.06 PROJECT CONDITIONS

- A. Coordinate work of this section with installation of mechanical ductwork .

1.07 WARRANTY

- A. Provide twenty year manufacturer warranty against distortion, metal degradation, and failure of connections.
 - 1. Finish: Include coverage against degradation of exterior finish.

PART 2 PRODUCTS

2.01 MANUFACTURERS

- A. Airolite Company, LLC: www.airolite.com.
- B. Construction Specialties, Inc: www.c-sgroup.com.
- A. Industrial Louvers, Inc: www.industriallouvers.com.
- C. Substitutions: See Section 01 6000 - Product Requirements.

2.02 LOUVERS

- A. Louvers: Factory fabricated and assembled, complete with frame, mullions, and accessories; AMCA Certified in accordance with AMCA 511.
 - 1. Wind Load Resistance: Design to resist positive and negative wind load of 25 psf without damage or permanent deformation.
 - 2. Intake Louvers: Design to allow maximum of 0.01 oz/sq ft water penetration at calculated intake design velocity based on design air flow and actual free area, when tested in accordance with AMCA 500-L.
 - 3. Drainable Blades: Continuous rain stop at front or rear of blade aligned with vertical gutter recessed into both jambs of frame.
 - 4. Screens: Provide insect screens at intake louvers and bird screens at exhaust louvers.
- B. Stationary Louvers: Horizontal blade, formed galvanized steel sheet construction, with intermediate mullions matching frame.
 - 1. Free Area: 50 percent, minimum.
 - 2. Static Pressure Loss: As required for proper operation of mechanical systems as designed. Provide test data confirming appropriate values in inches wg maximum per square foot of free area at indicated velocity(ies) in fpm, when tested in accordance with AMCA 500-L.
 - 3. Blades: Drainable.
 - 4. Frame: 4 inches deep, channel profile; corner joints mitered and, with continuous recessed caulking channel each side.
 - 5. Steel Thickness, Galvanized: Frame 16 gage, 0.0598 inch minimum base metal; blades 16 gage, 0.0598 inch minimum base metal.
 - 6. Steel Finish: Superior performing organic coatings, finished after fabrication.

2.03 MATERIALS

- A. Steel Sheet: Hot-dipped galvanized steel sheet, ASTM A653/A653M, with G90/Z275 coating.

2.04 FINISHES

- A. Primer: Zinc chromate, alkyd type.

2.05 ACCESSORIES

- A. Blank-Off Panels: Same material as louver, painted black on exterior side; provide where duct connected to louver is smaller than louver frame, sealing off louver area outside duct.

- B. Screens: Frame of same material as louver, with reinforced corners; removable, screw attached; installed on inside face of louver frame.
- C. Fasteners and Anchors: Stainless steel.
- D. Flashings: Of same material as louver frame, formed to required shape, single length in one piece per location.
 - 1. Flashing Felt: Imperforate asphalt saturated felt, ASTM D 226
- E. Sealant for Setting Sills and Sill Flashing: Non-curing butyl type.

2.06 FACTORY FINISHING

- A. Polyvinylidene Fluoride Coating: Minimum 70 percent Kynar 500/Hylar 500 resin, two coat finish, complying with AAMA 2604.
 - 1. Colors: As selected from manufacturer's standard colors. Minimum twenty-one (21) standard colors.
- B. Finishing: Apply factory finish to all surfaces that will be exposed in completed assemblies.
 - 1. Chemically clean, pre-treat and apply finishes after fabrication.
- C. Touch-Up Materials: As recommended by coating manufacturer for field application.

PART 3 EXECUTION

3.01 EXAMINATION

- A. Verify that prepared openings and flashings are ready to receive this work and opening dimensions are as indicated on shop drawings.
- B. Verify that field measurements are as indicated.

3.02 INSTALLATION

- A. Install louver assembly in accordance with manufacturer's instructions.
- B. Install louvers level and plumb.
- C. Install flashings and align louver assembly to ensure moisture shed from flashings and diversion of moisture to exterior.
- D. Secure louver frames in openings with concealed fasteners.
- E. Coordinate with installation of mechanical ductwork.

3.03 CLEANING

- A. Strip protective finish coverings.
- B. Clean surfaces and components.
- C. Touch-up surfaces damaged after installation so that no unfinished substrate is visible in completed assemblies, including joint edges.

END OF SECTION

SECTION 09 0511
CONCRETE FLOOR PREPARATION

PART 1 GENERAL

1.01 SUMMARY

- A. Mechanical cleaning of new concrete floor surfaces for application of finished flooring.

1.02 RELATED REQUIREMENTS

- A. Section 01 8113 - Sustainable Design Requirements.
- B. Division 03 Section - Cast-In-Place Concrete for concrete floor slabs.
- C. Division 07 Section - Water Vapor Emission Control System.
- D. Division 09 Sections for applied floor finishes.

1.03 REFERENCES

- A. ASTM C1583 - Standard Test Method for Tensile Strength of Concrete Surfaces and the Bond Strength or Tensile Strength of Concrete Repair and Overlay Materials by Direct Tension (Pull-off Method).
- B. ASTM D4258 - Standard Practice for Surface Cleaning Concrete for Coating.
- C. ASTM D4259 - Standard Practice for Abrading Concrete.
- D. California Code of Regulations, Title 24, Part 11 California Green Building Standards Code, "CAL-Green".
- E. California Code of Regulations, Title 24, Part 2, California Building Code (CBC), International Building Code.
- F. International Concrete Repair Institute (ICRI) Guideline No. 03732- Selecting and Specifying Concrete; Surface Preparation for Sealers, Coatings and Polymer Overlays.

1.04 ADMINISTRATIVE REQUIREMENTS

- A. Preinstallation Conference: Conduct conference at Project site to comply with requirements in Division 1 Section "Project Management and Coordination."
 - 1. Review conditions affecting substrate preparation.
 - 2. Review procedures that will be used for substrate preparation.
 - 3. Require attendance by Water Vapor Emission Control and Finish Flooring installers to review preparation requirements of floor finish product and flooring adhesive manufacturers

1.05 SUBMITTALS

- A. Product Data: For each type of mechanical cleaning equipment used on the project.
- B. CAL-Green Submittals:
 - 1. Dust Control Plan: Written description of materials and procedures used to control and remove dust from working area, prevent contamination of HVAC systems.
- C. Informational Submittals
 - 1. Qualification Data: For Installer performing surface preparation.
 - 2. Field quality-control reports.
 - a. Submit report of observations.
 - b. Certify installation is complete in accordance with acceptance criteria specified.
 - c. Indicate supplementary instructions provided for Project specific conditions.

1.06 QUALITY ASSURANCE

- A. Installer Qualifications: An entity that employs installers and supervisors who are trained in the use of the equipment and techniques required to produce the specified results.
- B. Mockups: Provide field mockups to set quality standards for surface preparation execution and for preconstruction testing.
 - 1. Provide mockup of typical surface preparation, minimum 100 sq. ft. area. Coordinate required size with requirements for preconstruction testing.
 - 2. Approval of mockups does not constitute approval of deviations from the Contract Documents contained in mockups unless Architect specifically approves such deviations in writing.
 - 3. Subject to compliance with requirements, approved mockups may become part of the completed Work..

PART 2 PRODUCTS - NOT USED

PART 3 EXECUTION

3.01 EXAMINATION

- A. Verify new concrete floors have cured minimum 28 days.
- B. Examine substrates, with Installer (s) present, for compliance with requirements for surface contamination, damage, and other conditions affecting performance of the Work.
- C. Examine substrate to determine repairs required to restore substrate surface to be within tolerances required for floor finishes specified in other sections, prior to completing Work of this section.
- D. Examine substrate to verify surfaces prepared in accordance with this section will be suitable for application of finishes specified in other sections.
- E. Prepare written report, endorsed by Installer, listing conditions detrimental to performance with recommendations for methods and materials required to correct conditions before proceeding with work of this section.
- F. Proceed with surface preparation only after unsatisfactory conditions have been corrected.
 - 1. Proceeding with surface preparations indicates acceptance and of surfaces and conditions of substrate.

3.02 SURFACE PREPARATION EQUIPMENT

- A. Mechanical Cleaning Equipment: Automatic, dry shot blast type, self contained capable of recycling blast materials and collecting surface abrasions.

3.03 SURFACE PREPARATION

- A. Protection: Mask and protect walls, equipment from adjacent work and finishes during installation process.
- B. Mechanically clean concrete substrate and create surface profile in existing concrete substrate in accordance with ASTM D 4259 as required to meet acceptance criteria specified.
 - 1. Acceptable methods include shotblasting, scarifying or grinding. Grinding is only acceptable in locations unreachable by shotblast or scarification equipment.
- C. Acceptance Criteria:
 - 1. Surface profile of ICRI CSP 3 minimum, and greater as required by coating manufacturer in related sections, all in accordance with ICRI Technical Bulletin No. 03732.
 - 2. Tensile Strength of Concrete Surface: 200 psi minimum according to ASTM C1583 Test Method.
 - 3. Free of laitance, oil, grease, flooring adhesive, paint, and other surface contaminants capable of affecting bond of specified floor coatings and finishes to concrete substrate.

- D. If floor develops areas of surface roughness greater than ICRI CSP-4 during preparation, apply patching/leveling compound in those areas and re-abrade to produce specified profile.
- E. Repair surface irregularities after cleaning.
 - 1. Fill bugholes, spalls, cracks, deteriorated joints and other surface damage exposed or created as a result of substrate cleaning operations flush with adjacent surfaces to provide sound substrate for specified floor finish.
- F. Dry broom or vacuum clean concrete substrates immediately before application of specified floor finishes in accordance with ASTM D 4258 to remove loose materials on substrate surface.
- G. When field quality control report indicates portions are unsatisfactory, repeat process until field quality control report indicates there are no unsatisfactory portions remaining.
 - 1. Areas of insufficient strength shall be ground to remove weak materials and abrasively prepared again using appropriately modified methods. Retest these areas for tensile strength until compliance is determined.

3.04 FIELD QUALITY CONTROL

- A. Testing Agency: Owner will engage a qualified testing and inspecting agency to perform the following field tests and inspections and prepare test reports:
 - 1. Visual inspection of completed substrate preparation to verify contamination is removed.
 - 2. Visual inspection of completed substrate preparation to verify surface profile matches ICRI profile required for specified coating or finish, using ICRI standard rubber mold for visual comparison.
 - 3. Test tensile strength of the concrete surface according to ASTM C1583 Test Method to verify tensile strength of 200 psi minimum.
 - 4. Prepare field quality control report. Clearly indicate the locations, extents, and conditions of areas where surface preparation does not conform to specified profile and cleanliness. Document observed conditions with digital photographs.
 - 5. Repeat inspections when additional surface preparation for unsatisfactory conditions indicated in the previous field quality control report is completed.

3.05 PROTECTION

- A. Protect prepared concrete substrates from contamination. Reclean substrates that are contaminated by construction operations prior to installation of specified floor coatings or finishes.

END OF SECTION

SECTION 09 0512

CONCRETE FLOOR MOISTURE CONTENT AND PH TESTING

PART 1 GENERAL

1.01 SUMMARY

- A. Concrete moisture content testing using relative humidity method.
- B. Concrete pH testing.

1.02 RELATED REQUIREMENTS

- A. Pertinent section of Division 07 specifying water vapor emission control coating.
- B. Pertinent section of Division 09 specifying concrete floor preparation.
- C. Division 09 flooring sections specifying flooring and accessories requiring moisture and pH testing.

1.03 REFERENCES

- A. ASTM F2170-09 Standard Test Method for Determining Relative Humidity in Concrete Floor Slabs Using in situ Probes.
- B. California Code of Regulations, Title 24, Part 11 California Green Building Standards Code, "CAL-Green".
- C. California Code of Regulations, Title 24, Part 2, California Building Code (CBC), International Building Code with California Amendments.

1.04 ADMINISTRATIVE REQUIREMENTS

- A. Preinstallation Conference: Conduct conference at Project site to comply with requirements in Division 1 Section "Project Management and Coordination."
- B. Scheduling: Schedule work to permit concrete moisture testing to be completed minimum one week and maximum 3 weeks before floor coverings are installed.

1.05 SUBMITTALS

- A. Product Data:
 - 1. Submit data indicating model, manufacturer, and calibration record for relative humidity measuring equipment.
 - 2. Submit data for pH test material products.
- B. Shop Drawings:
 - 1. Indicate test locations shown on building floor plan,
- C. Informational Submittals:
 - 1. Test Reports: Based on evaluation of comprehensive tests performed by a qualified testing agency, for concrete moisture acceptable limits. Report test results in chart form.
 - a. Relative Humidity Test Method: Indicate test dates, time, depth of test well, in-situ temperature, relative humidity and pH levels.
 - b. Submit record of ambient air temperature, ambient relative humidity, and floor slab surface temperature when test sites are prepared, start of test, and end of test.
 - c. Indicate condition of building enclosure including position of operable windows and exterior doors when test sites are prepared, start of test, and end of test.
 - d. Submit transcript of datalogger.

- e. Indicate operational status of HVAC systems maintaining environmental condition of spaces where tests are conducted when test sites are prepared, start of test, and end of test.

1.06 FIELD CONDITIONS

- A. Ambient Conditions:
 - 1. Do not perform concrete moisture testing until building is enclosed and HVAC system is operational.
 - 2. Maintain building test areas at design operating conditions for minimum 48 hours before, during, and continuously after conducting testing.
 - 3. When HVAC system is not operational at start of tests, maintain ambient conditions within test areas at 65 to 85 degrees F and 40 to 60 percent relative humidity for minimum 48 hours before, during, and continuously after conducting testing until building HVAC system is capable of maintaining design operating conditions.

PART 2 PRODUCTS

2.01 RELATIVE HUMIDITY TEST EQUIPMENT

- A. Manufacturers: Subject to compliance with requirements, provide products by one of the following:
 - 1. Vaisala www.vaisala.com.
 - 2. Wagner Moisture Meters, Rapid RH, www.wagnermeters.com.
 - 3. Substitutions: Section 01 6000.
- B. Humidity and Temperature Probe and Meter: Comply with ASTM F2170.

2.02 PH TEST MATERIALS

- A. Manufacturers: Subject to compliance with requirements, provide products by one of the following:
 - 1. Micro Essential Laboratory www.microessentiallab.com.
 - 2. Substitutions: Section 01 6000.
- B. pH Test Paper: Capable of indicating minimum 7.0 to 13 pH range.
- C. pH Color Gage: Furnish pH test paper manufacturer's visual color gage to identify measured pH.
- D. Water: Distilled or de-ionized.

PART 3 EXECUTION

3.01 EXAMINATION

- A. Verify new concrete floors have cured minimum 28 days.

3.02 PREPARATION

- A. When a building HVAC system is not operational and maintaining test areas at design operational conditions, install recording hygrometer or data logger in each separate test area to record ambient temperature and relative humidity beginning 48 hours before start of tests until completion of tests within each area.
- B. Identify three moisture test sites for first 1,000 sf and one moisture test site for each additional 1,000 sf of floor area receiving floor covering on each separate floor slab.
 - 1. Uniformly distribute test site locations throughout each test area.

3.03 FIELD QUALITY CONTROL

- A. Testing Agency: Owner will engage a qualified testing and inspecting agency to perform concrete moisture tests and inspections and prepare test reports.
 - 1. Test all concrete slabs (on grade and elevated) in accordance with ASTM F-2170, not more than 45 days prior to the installation of the finished flooring. Test all floors scheduled to receive adhered

floor coverings, such as hardwood, wood athletic flooring, bamboo, carpet, resilient tile, resilient sheet goods, rubber, fluid-applied, cork tile, ceramic tile, cementitious and epoxy resin terrazzo, and porcelain tile.

- B. Acceptance Criteria at HVAC Design Operating Conditions:
 - 1. Relative Humidity Test Result: 75 percent maximum relative humidity.
 - 2. pH Test Result: Within alkalinity range of 7.0 to 9.0.
 - 3. When concrete floors do not meet acceptance criteria, apply coating per related Section "Water Vapor Emission Control System".
- C. Concrete Moisture Testing - General
 - 1. Conduct relative humidity test at each test site.
 - 2. Conduct one pH test at each test site.
- D. Relative Humidity Testing:
 - 1. Perform tests in accordance with ASTM F2170.
 - 2. Conduct relative humidity testing at the following depths:
 - a. Slabs-On-Grade: Measure temperature and relative humidity at 40 percent of slab thickness measured from top surface.
 - b. Elevated Slabs: Measure temperature and relative humidity at 20 percent of slab thickness measured from top surface.
 - 3. Drill test hole at each test site to accommodate test sleeve.
 - a. Hole Diameter: In accordance with test equipment manufacturer's instructions.
 - b. Drilling Fluids: Not permitted.
 - 4. Vacuum dust and debris from test hole.
 - 5. Insert sleeve, to the full depth of test hole. Cap or plug sleeve to prevent test hole contamination.
 - 6. Permit the test site to acclimate for minimum 72 hours before measuring relative humidity.
 - 7. Remove sleeve plug and insert probe to bottom of test hole. Allow test probe to reach temperature equilibration with concrete slab.
 - 8. Measure and record temperature and relative humidity at the test site.
 - 9. Record and report results.
- E. pH Testing:
 - 1. Place several drops of water onto the concrete surface to form a puddle approximately 1 inch in diameter.
 - 2. Allow the water to set for approximately 60 seconds
 - 3. After 60 seconds, dip the pH paper into the water and remove immediately, compare color to chart provided by paper supplier to determine pH reading.
 - 4. Record and report results.

3.04 PROTECTION

- A. Protect tested concrete substrates from contamination. Reclean substrates that are contaminated by construction operations prior to installation of specified water vapor emission control coating, floor coatings or finishes.

END OF SECTION

SECTION 09 2116
GYPSUM BOARD ASSEMBLIES

PART 1 GENERAL

1.01 SECTION INCLUDES

- A. Gypsum wallboard.
- B. Joint treatment and accessories.
- C. Textured finish system.

1.02 RELATED REQUIREMENTS

- A. Section 01 6116 - Volatile Organic Compound (VOC) Content Restrictions.
- B. Section 06 1000 - Rough Carpentry: Building framing and sheathing.
- C. Section 07 2100 - Thermal Insulation.
- D. Section 08 8400 - Firestopping.
- E. Division 09: Pertinent sections specifying finishes installed over gypsum board substrates.
- F. Divisions 22 and 23: Pertinent sections specifying building utility systems penetrating gypsum board.

1.03 REFERENCE STANDARDS

- A. ANSI A118.9 - American National Standard Specifications for Test Methods and Specifications for Cementitious Backer Units.
- B. ANSI A108.11-SystemDeleted - American National Standard for Interior Installation of Cementitious Backer Units.
- C. ASTM C475/C475M - Standard Specification for Joint Compound and Joint Tape for Finishing Gypsum Board.
- D. ASTM C557 - Standard Specification for Adhesives for Fastening Gypsum Wallboard to Wood Framing.
- E. ASTM C 635, Standard Specifications for Metal Suspension Systems.
- F. ASTM C 636, Recommended Practice for Installation of Metal Suspension Systems.
- G. ASTM C645 - Standard Specification for Nonstructural Steel Framing Members.
- H. ASTM C754 - Standard Specification for Installation of Steel Framing Members to Receive Screw-Attached Gypsum Panel Products.
- I. ASTM C840 - Standard Specification for Application and Finishing of Gypsum Board.
- J. ASTM C1047 - Standard Specification for Accessories For Gypsum Wallboard and Gypsum Veneer Base.
- K. ASTM C1325 - Specification for Non-Asbestos Fiber-Mat Reinforced Cementitious Backer Units.
- L. ASTM C1396/C1396M - Standard Specification for Gypsum Board.
- M. ASTM C1658/C1658M - Standard Specification for Glass Mat Gypsum Panels.
- N. ASTM D3273 - Standard Test Method for Resistance to Growth of Mold on the Surface of Interior Coatings in an Environmental Chamber.

- O. ASTM E84 - Standard Test Method for Surface Burning Characteristics of Building Materials.
- P. ASTM E 119 - Standard Test Methods for Fire Tests of Building Construction and Materials.
- Q. CISCA Ceiling Systems Installation Handbook.
- R. California Code of Regulations, Title 24, Part 2, California Building Code (CBC), International Building Code.
- S. California Code of Regulations, Title 24, Part 11, California Green Building Standards Code, "CAL-Green".
- T. Division of the State Architect (DSA) Interpretation of Regulations: IR 25-3, Drywall Ceiling Suspension Conventional Construction One-Layer.
- U. GA-214 - Recommended Levels of Gypsum Board Finish; Gypsum Association
- V. GA-216 - Application and Finishing of Gypsum Board.
- W. California Building Code, Title 24, Part 2, California Building Code, Chapter 8.
- X. UL (FRD) - Fire Resistance Directory.

1.04 SUBMITTALS

- A. See Section 01 3300 - Submittals, for submittal procedures.
- B. Provide complete submittals at the same time as submittals for work in related sections to permit review of complete and integrated systems and assemblies.
- C. Product Data: Provide data on gypsum board.
- D. CAL-GREEN Submittals: Product Data - VOC Limits: For adhesives sealants, fillers, primers and coatings, documentation including printed statement of VOC contents, comply with limits specified in related section.
- E. Samples: Submit two samples of gypsum board finished with proposed texture application, 12 by 12 inches in size, illustrating finish color and texture.

1.05 QUALITY ASSURANCE

- A. Perform in accordance with ASTM C 840. Comply with requirements of GA-600 for fire-rated assemblies.
 - 1. Maintain one copy of standards at project site.
- B. Installer Qualifications: Company specializing in performing gypsum board installation and finishing, with minimum 5 years of experience.

PART 2 PRODUCTS

2.01 PERFORMANCE REQUIREMENTS

- A. VOC Limits for adhesives, sealants, fillers, primers and coatings . Comply with limits specified in related section.

2.02 GYPSUM BOARD ASSEMBLIES

- A. Provide completed assemblies complying with ASTM C840 and GA-216.

2.03 BOARD MATERIALS

- A. Manufacturers - Gypsum-Based Board:
 - 1. Georgia-Pacific Gypsum: www.gpgypsum.com.

2. National Gypsum Company: www.nationalgypsum.com.
 3. PABCO Gypsum: www.pabco gypsum.com.
 4. USG Corporation: www.usg.com.
- B. Gypsum Wallboard: Paper-faced gypsum panels as defined in ASTM C1396/C1396M; sizes to minimize joints in place; ends square cut.
1. Application: Use for vertical surfaces and ceilings, unless otherwise indicated.
 2. Glass mat faced gypsum panels as defined in ASTM C1658/C1658M, suitable for paint finish, of the same core type and thickness may be substituted for paper-faced board.
 3. Mold Resistance: Score of 10, when tested in accordance with ASTM D3273.
 - a. Mold resistant board is required at all locations.
 4. At Assemblies Indicated with Fire-Rating: Use type required by indicated tested assembly; if no tested assembly is indicated, use Type X board, UL or WH listed.
 5. Thickness:
 - a. Vertical Surfaces: 5/8 inch.
 - b. Ceilings: 5/8 inch.
 - c. Multi-Layer Assemblies: Thicknesses as indicated on drawings.
- C. Backing Board For Wet Areas:
1. Application: Surfaces behind tile in wet areas including toilet rooms.
 2. Mold Resistance: Score of 10, when tested in accordance with ASTM D3273.
 3. ANSI Cement-Based Board: Non-gypsum-based; aggregated Portland cement panels with glass fiber mesh embedded in front and back surfaces complying with ANSI A118.9 or ASTM C1325.
 - a. Thickness: 1/2 inch.
 - b. Products:
 - 1) Custom Building Products: www.custombuildingproducts.com/#sle.
 - 2) National Gypsum Company; PermaBase Cement Board: www.nationalgypsum.com/#sle.
 - 3) USG Corporation: www.usg.com/#sle.
- D. Ceiling Board: Special sag resistant gypsum ceiling board as defined in ASTM C1396/C1396M; sizes to minimize joints in place; ends square cut.
1. Application: Ceilings, unless otherwise indicated.
 2. Thickness: 5/8 inch.
 3. Edges: Tapered.
- E. Moisture-Resistant Gypsum Backing Board: ASTM C1396/C1396M; ends square cut. Fire-rated Type X where occurring in designated rated assemblies.
1. Thickness: 5/8 inch.
 2. Edges: tapered.

2.04 ACCESSORIES

- A. Acoustic Insulation: Acoustic fiberglass batt type specified in Section 07 2100.
- B. Finishing Accessories: ASTM C1047, galvanized steel or rolled zinc, unless otherwise indicated. Mechanically fastened.
1. Types: As detailed or required for finished appearance.
 2. Special Shapes: In addition to conventional cornerbead and control joints, provide U-bead at exposed panel edges.
- C. Joint Materials: ASTM C 475 and as recommended by gypsum board manufacturer for project conditions. Water resistant where used with water resistant backer board.
1. Tape: 2 inch wide, coated glass fiber tape for joints and corners, except as otherwise indicated.
 2. Tape: 2 inch wide, creased paper tape for joints and corners, USG "Perf-A-Tape", or equal.

3. Ready-mixed vinyl-based joint compound.
 4. Chemical hardening type compound.
- D. High Build Drywall Surfer: Vinyl acrylic latex-based coating for spray application, designed to take the place of skim coating and separate paint primer in achieving Level 5 finish.
- E. Textured Finish Materials: Latex-based compound; plain.
- F. Screws: ASTM C 1002; self-drilling type. Lengths as required for minimum penetration into support members per reference standards.
1. For Wood: "Type W".
 2. For Metal: "Type S".
 3. For joint backing: "Type G".
- G. Anchorage to Substrate: Tie wire, nails, screws, and other metal supports, of type and size to suit application; to rigidly secure materials in place.
- H. Adhesives
1. Modified contact adhesive: As recommended by the gypsum board manufacturer and having a placement time before setting of at least 15 minutes.
 2. Joint compound adhesive: As recommended by the gypsum board manufacturer.

PART 3 EXECUTION

3.01 EXAMINATION

- A. Verify that project conditions are appropriate for work of this section to commence.
- B. Verify that framed substrates demonstrate flatness characteristics such that work of this section will meet specified tolerances.

3.02 INSTALLATION - GENERAL

- A. Install materials in accordance with gypsum board application and finishing standards referenced.
 1. Single layer application: Screw attachment.
 2. Float interior angles, except where required to conform to fire or acoustical separation requirements.
 3. Do not install scored, scratched, broken, damp, or otherwise damaged boards.
 4. Smooth cut edges and ends to obtain neat fitting joints.

3.03 ACOUSTIC ACCESSORIES INSTALLATION

- A. Acoustic Insulation: Place tightly within spaces, around cut openings, behind and around electrical and mechanical items within partitions, and tight to items passing through partitions.
- B. Acoustic Sealant: Install in accordance with manufacturer's instructions.
 1. Place one bead continuously on substrate before installation of perimeter framing members.
 2. Place continuous bead at perimeter of each layer of gypsum board.
 3. Seal around all penetrations by conduit, pipe, ducts, and rough-in boxes, except where firestopping is provided.

3.04 INSTALLATION OF TRIM AND ACCESSORIES

- A. Control Joints: Place control joints consistent with lines of building spaces and as directed.
- B. Corner Beads: Install at external corners, using longest practical lengths.
- C. Edge Trim: Install at locations where gypsum board abuts dissimilar materials.

3.05 JOINT TREATMENT

- A. Glass Mat Faced Gypsum Board and Exterior Glass Mat Faced Sheathing: Use fiberglass joint tape, bedded and finished with chemical hardening type joint compound.
- B. Paper Faced Gypsum Board: Use paper joint tape, bedded with ready-mixed vinyl-based joint compound and finished with ready-mixed vinyl-based joint compound.
- C. Finish gypsum board in accordance with levels defined in ASTM C 840, and required by Section 09 9000 Painting and Coating, as follows:
 - 1. Level 5: Corridor walls to receive eggshell paint finish.
 - 2. Level 5: Walls and ceilings to receive semi-gloss or gloss paint finish and other areas specifically indicated.
 - 3. Level 4: Walls and ceilings to receive paint finish or wall coverings, unless otherwise indicated.
 - 4. Level 3: Walls to receive textured wall finish.
 - 5. Level 3: Ceilings to receive glued on acoustical ceiling tiles.
 - 6. Level 2: Behind cabinetry and on backing board to receive tile finish.
 - 7. Level 1: Fire rated wall areas above finished ceilings, whether or not accessible in the completed construction.
- D. Tape, fill, and sand exposed joints, edges, and corners to produce smooth surface ready to receive finishes.
 - 1. Feather coats of joint compound so that camber is maximum 1/32 inch.
- E. Where Level 5 finish is indicated, spray apply high build drywall surfacer over entire surface after joints have been properly treated; achieve a flat and tool mark-free finish.

3.06 TEXTURE FINISH

- A. Apply finish texture coating by means of spraying apparatus in accordance with manufacturer's instructions and to match approved sample.
- B. Texture Required: .
 - 1. Finish Texture: Medium Orange Peel at walls and ceiling unless otherwise noted.
 - 2. No finish texture at Level 5 joint treatment walls and ceilings as noted.

3.07 TOLERANCES

- A. Maximum Variation of Finished Gypsum Board, Tack Board, or Cementitious Board Surface from True Flatness: 1/8 inch in 10 feet in any direction.

END OF SECTION

SECTION 09 2513

ACRYLIC-MODIFIED PORTLAND CEMENT PLASTER

PART 1 GENERAL

1.01 SECTION INCLUDES

- A. Acrylic-Modified Portland cement plaster assemblies for installation over metal lath.
 - 1. Over framed substrates.
 - 2. Over solid substrates.

1.02 RELATED SECTIONS

- A. Pertinent Sections specifying Volatile Organic Compound (VOC) Content Restrictions.
- B. Sections specifying structural support framing for plaster.
- C. Section 07 2500 specifying Weather Barriers.
- D. Section 07 6200 - Sheet Metal Flashing and Trim.
- E. Section 07 9200 - Joint Sealers.
- F. Sections specifying work penetrating plaster assemblies.

1.03 REFERENCES

- A. California Building Code (CBC) Title 24, Part 2, Chapter 25 and DSA IR 25-4.
- B. California Code of Regulations, Title 24, Part 11 California Green Building Standards Code, "CAL-Green".
- C. ASTM C 847 - Standard Specification for Metal Lath.
- D. ASTM C 926 - Standard Specification for Application of Portland Cement-Based Plaster.
- E. ASTM C 1032 - Standard Specification for Woven Wire Lath
- F. ASTM C1063 - Standard Specification for Installation of Lathing and Furring to Receive Interior and Exterior Portland Cement-Based Plaster.
- G. Manufacturer's specifications and recommendations.

1.04 SUBMITTALS

- A. See Section 01 3300 - Submittals, for submittals procedures.
- B. Product Data: Provide data on plaster materials, characteristics and limitations of products specified. Include mix design for each coat. Demonstrate compliance with specified requirements.
- C. CAL-GREEN VOC Submittals: For adhesives sealants, fillers, coatings and primers, documentation including printed statement of VOC contents, comply with limits specified in related section.
- D. Samples: Submit two samples, 12 x 12 inch in size illustrating finish color and texture. Provide color samples of sealants. Provide physical samples of each type of fastener and anchorage.
- E. Shop Drawings:
 - 1. Location, installation and pattern, fully dimensioned, of all control joints, expansion joints, embedments, inserts, penetrations and all other items that will visually affect the plaster surface for all visible portions of the plaster surfaces.
 - 2. Shop drawings shall be to scale and depict all visible surfaces.
 - 3. Include plans, elevations, sections, details of components, and attachments to other work.

4. Location of all elements and joints is subject to approval of the Architect.
- F. Installer's Qualification statement.
- G. Warranties: Special warranties specified in this Section.

1.05 QUALITY ASSURANCE

- A. Perform Work in accordance with ASTM C 926.
- B. Regulatory requirements: All plaster work shall be performed in accordance with requirements of California Building Code (CBC) Title 24, Part 2, Chapter 25, ASTM C1063 and DSA IR 25-4.
- C. Fire-Resistance Ratings: Where fire resistance ratings are indicated on the drawings, provide portland cement plaster assemblies identical to those of assemblies tested for fire resistance per ASTM E 119 by a qualified testing agency. Identify products with appropriate markings of applicable testing agency.
 1. Conform to California Building code for fire rated assemblies as indicated on drawings.
 2. Coordinate components of fire rated assemblies with materials specified for support of plaster in other sections.
- D. Sound-Transmission Characteristics: Where indicated, provide portland cement plaster assemblies identical to those of assemblies tested for STC ratings per ASTM E 90 and classified according to ASTM E 413 by a qualified testing agency.
- E. Manufacturer Qualifications: Company specializing in manufacturing the products of this section with minimum five years of documented experience.
- F. Installer Qualifications: Installer shall be listed with Acrylic-Modified Portland Cement Plaster Systems Manufacturer as a trained contractor and shall possess a current Manufacturer-trained contractor certificate.

1.06 MOCK-UP

- A. Construct mock-up of exterior wall, 8 feet long by 8 feet wide, illustrating surface finish.
 1. Locate where directed.
 2. Mock-up may remain as part of the Work.
- B. Mockups: Build mockups to demonstrate aesthetic effects and set quality standards for materials and execution.
 1. Within 120 days of mobilization, provide minimum 4'-0" x 12'-0" x 8'-0" tall onsite mock up, including field area, outside corner, full window opening (with window, head and jamb trim and sill), and representative examples of other design conditions for review and approval by Architect prior to commencing actual work.
 - a. Demonstrate the proposed range of color, texture and workmanship to be expected in the completed work, including Specialty Finishes where indicated.
 - b. Include through-wall flashing installed for a 24-inch length in corner of mockup approximately 16 inches down from top of mockup, with a 12-inch length of flashing left exposed to view (omit finish above half of flashing).
 - c. Include framing studs, sheathing, flashing in exterior wall mockup.
 - d. Show a cut-away in the panel exposing the water-resistive barriers, metal lath and drainage weep of the system on a perimeter edge of the panel.
 - e. Install plaster over the top of the mockup to duplicate the project plaster parapet, including waterproofing material and parapet cap.
 - f. Include foundation weep screed, corner trim, vertical expansion joint and horizontal control joint.
 - g. Include a sealant-filled joint at least 48 inches long in mockup.

- h. Construct additional panels until finish, color and consistency is approved by Architect.
2. Obtain Architect's acceptance of visual qualities of the sample panel. Approval of mockups is for color, texture, tooling of joints; and aesthetic qualities of workmanship.
 - a. Approval of mockups is also for other material and construction qualities Architect specifically approves in writing, including required tests of installed windows, as described in related Sections specifying Windows and Curtain Wall.
 - b. Approval of mockups does not constitute approval of deviations from the Contract Documents contained in mockups unless Architect specifically approves such deviations in writing.
3. Mock up or portions of mockup may require more than one iteration and shall be erected in a long term location near the building.
4. Approved mockup will become the standard for comparison for Architect's judging aesthetic qualities of the finished work.
5. Maintain and protect mockup throughout the construction process and dispose of when project is completed.

1.07 FIELD CONDITIONS

- A. Do not apply plaster when substrate or ambient air temperature is outside the manufacturer's recommended ranges.
- B. Maintain manufacturer's recommended minimum ambient temperature during installation of plaster and until cured.
- C. Application of materials shall not take place during inclement weather unless appropriate protection is provided. Protect materials from inclement weather.
- D. Load roofing materials onto the roof and stock interior gypsum wallboard in the building prior to the installation of cement plaster.
- E. Protect the materials from uneven and excessive evaporation in warm windy weather. Always work the shady side of the wall.

1.08 WARRANTY

- A. Warranty: Standard form in which manufacturer agrees to repair or replace plaster system finishes that fail in materials or workmanship within specified warranty period.
 1. Failures include, but are not limited to, the following:
 - a. Manufacturing defects.
 - b. Structural failures including cracking in excess of 3/32 -inch or by PCA standards.
 - c. Shrinkage.
 - d. Finish coat color fading.
 - e. Failure of system to resist penetration of water.
 - f. Failure of system to resist damage from wind.
 - g. Hairline cracking due to temperature or shrinkage is not considered structural failure.
 2. Single Source System Warranty Period: 15 years from date of Substantial Completion covering base coats, lamina, primer and 100% acrylic or elastomeric finish.
- B. Assist the Owner to properly execute the warranty request forms.

PART 2 PRODUCTS

2.01 SYSTEM DESCRIPTION

- A. VOC Limits for adhesives sealants, fillers and primers. Comply with limits specified in related section.
- B. Design Requirements:

1. Extend complete plaster assembly behind surface installed fixtures and trim.
 2. Two layers of building paper beneath lath at all locations.
- C. Provide Products exhibiting the following characteristics when tested as follows:
1. ASTM C 109: Compressive Strength: 13.9 Mpa (2020 psi)
 2. ASTM C 348: Flexural Strength: 3.0 Mpa (570 psi)
 3. ASTM C 190: Tensile Strength: 1.2 Mpa(180 psi)
 4. ICBO Procedure: Freeze/Thaw cycling: No cracking, checking or delamination
 5. ASTM E 514: Water Vapor Permeability: 415 ng/ (7.2 Perms)
 6. ASTM E 72: Transverse Load Strength: Wood Studs - 468.7 kg. m2 (96 psf) Metal Studs -673.8 kg/ m2 (138 psf)
 7. ASTM E 119: Fire Resistive Wall Assembly, acceptable as part of One-Hour Assembly.
 8. MIL STD 810B: Mildew Fungus Resistance -Passed
 9. ASTM B 117: Salt Spray Resistance - 300 hrs, no deleterious effects.
 10. ASTM D 968: Abrasion Resistance - 500 L(132 gal), no deleterious effects.
 11. ASTM G 53: Accelerated Weathering - 5000 hrs, Passed.
- D. Expansion Control: Design orientation, and location of expansion and control joints shall be determined by the Architect and as shown on the drawings. If joints are required by the following criteria and are not shown on the drawings, recommend joint locations on Shop Drawings for the Architect's approval. Do not modify aesthetic effect of joint locations shown on drawings or provide joints not shown on drawings without Architect's written approval.
1. Expansion Joints: Required at the following locations:
 - a. Where expansion joints occur in the substrate system.
 - b. Where building expansion joints occur.
 - c. At floor lines.
 - d. Where plaster abuts dissimilar materials.
 - e. Where the substrate material changes.
 - f. Where significant structural movement occurs such as changes in roofline, building shape or structural system.
 2. Control joints: Horizontal and Vertical, required in accordance with ASTM C 1063 and as indicated on the contract drawings in the following locations:
 - a. Corners of openings
 - b. Such that monolithic wall areas do not exceed 144 ft2.
 - c. Length to width ratios of wall areas shall not exceed 2.5:1.
 - d. Maximum spacing of control joints shall not exceed 18 ft.
 - e. At intersections of natural breaks in walls and above opening jambs.
- E. Performance Requirements:
1. Finish surfaces flat, true, and plumb to plus or minus 1/4-inch in 10 feet.
 2. Provide weather tight assembly.

2.02 MANUFACTURER

- A. Source Limitations: All components of the Acrylic-Modified Plaster System shall be provided from a single manufacturer.
- B. Provide factory-mixed plaster. Job-site mixed plaster is not acceptable.
1. Provide ready-mixed products in minimum 90 lb. sacks, supersacks or in pre-mixed silos.
- C. Basis of Design Products:
1. BMI 690 Plaster with 100 % Acrylic Primer & Finish, manufactured by BMI Products, 990 Ames Avenue, Milpitas, CA 95035-6303, (408) 293-4008, www.bmi-products.com, Jerry L. Pozo, BS, CSI, CDT

a. ICC-ES Report ESR 2535.

- D. Acceptable Alternate:
 - 1. Dryvit TAFS (Textured Acrylic Finishes),
- E. Substitutions: See Section 01 6000.

2.03 PLASTER MATERIALS

- A. Plaster Base Coat: "BMI 690 Plaster": A premium pre-blended cement-lime-sand mixture with fiber that has been specially formulated for the scratch and brown coat. This pre-blended product assures consistent quality throughout the project.
- B. Polymer-Modified Base Coat: Apply in thin layer over Brown Coat as Lamina/Leveling Coat to embed reinforcing lamina and mesh and provide uniform substrate for finish application.
 - 1. BMI 777 base coat, fiber-reinforced, high-performance polymer modified dry cementitious base coat specifically formulated for use in embedding mesh. Mix with water per instructions.
- C. Reinforcing Mesh: "Standard Reinforcing Mesh": Open-weave fiberglass mesh with integral treatment for related materials compatibility. Manufacturer's standard products in 4.5 oz and 6.0 oz./sq. yd. as appropriate for application.
- D. Primer: 100% acrylic color primer; Water-based, pigmented acrylic primer applied over the cured plaster base coat to improve adhesion and provide more uniform finish appearance.
 - 1. BMI 100 Acrylic Primer.
- E. Textured Finish: 100% acrylic finish with integral color and texture.
 - 1. BMI 400 Medium Finish, "Sandblast" medium texture. Color as selected by Architect from full range of available choices.

2.04 WEATHER-RESISTIVE BARRIER

- A. Building Paper: Type specified in related Section 07 2500.
- B. Flexible Flashing: Type specified in related Section 07 2500.
- C. Sheet Metal Flashing: Type specified in related Section 07 6200.

2.05 METAL LATH

- A. Lath:
 - 1. Sheathed Framed Walls: Metal Lath conforming to CBC Chapter 25, ASTM C847, ASTM C1032 and ASTM C1063, un-backed, for installation over two continuous layers of building paper as required by code.
 - a. Metal Lath: Self-Furred Diamond Mesh Metal Lath (grooved), ASTM C 847 with ASTM A 653/A 653M, G60 (Z180), hot-dip galvanized zinc coating, 2.5 lbs/sq.yd. as manufactured by CEMCO, www.cemcosteel.com.
 - b. Welded Wire Lath: 1.14 lbs/sq.yd., galvanized steel, "Structalath, No.17 (wood framing), SF CR Twin trac" (ICC ESR-2017) as manufactured by Structa Wire Lath, www.structawire.com.
 - c. Woven Wire Fabric lath: ASTM C1032, 1-1/2 inch opening, 17 gauge, self-furring with stiffener wire, un-backed.
 - 2. Framed horizontal soffits:
 - a. Flat Rib Expanded metal lath, ASTM C847 with ASTM A 653/A 653M, G60 (Z180), hot-dip galvanized zinc coating: 3.4 lbs./sq. yd., galvanized steel, 3/8 inch rib as manufactured by CEMCO.
 - b. Welded wire lath: 2.2lbs./sq.yd., galvanized steel, paper backed "V Truss Wall & Ceiling - Rib lath" (ICC ESR-2017) as manufactured by Structa Wire Lath, www.structawire.com.

- B. Lath Anchorage: Nails, staples, or other metal supports conforming to requirements of referenced standards, of type and size to suit application and conforming to requirements of CBC Chapter 25 for conditions indicated, galvanized, to rigidly secure lath and associated metal accessories in place.
 - 1. Install metal lath on sheathed framed walls using self furring fasteners.
 - 2. Install expanded metal lath on framed horizontal soffits using self-furring fasteners and j-nails as detailed on the Drawings.

2.06 LATH ACCESSORIES

- A. General: Galvanized steel, unless otherwise specified.
- B. Manufacturers:
 - 1. Alabama Metal Industries Corporation (AMICO); a Gibraltar Industries company.
 - 2. CEMCO.
 - 3. Clark Western Building Systems.
 - 4. Stockton Products, www.stocktonproducts.com.
 - 5. Substitutions: Section 01 6000.
- C. Reinforcement
 - 1. Interior Corners: CEMCO, No. 30 Corner Expansion Joint.
 - 2. Exterior Corners: CEMCO No. 1A Expanded Corner Bead.
- D. Screeds and Molds: Per Plaster and Drywall Systems Manual, size and profile as indicated on the Drawings and as necessary to suit application.
 - 1. 26 gauge galvanized steel. Hem exposed edges. Furnish in longest possible lengths.
 - 2. Furnish drip screeds with weep holes every 2-inches.
- E. Expansion and Control Joints
 - 1. Vertical Joints
 - a. Control Joints: CEMCO No.XJ-15; Size as noted on Drawings.
 - b. Expansion Joints: CEMCO No. 40; Size as noted on Drawings.
 - 2. Horizontal Control Joints: CEMCO No. 15; Size as noted on Drawings.
 - 3. Two-Piece Expansion Joints (story drift): Fabricated from zinc or zinc-coated (galvanized) steel; formed to produce slip-joint and square-edged reveal that is adjustable from 1/4 -inch to 5/8 - inch wide; with perforated flanges. Fabricate with 3 -inch minimum vertical legs.
 - 4. Diagonal Joints: Type as noted on Drawings.
- F. Extruded Aluminum Accessories: Provide components fabricated from 6063-T5 aluminum alloy and temper. Provide metal reveals, drip screeds, and other shapes and sizes as indicated on the Drawings, in sizes required for plaster thickness.
 - 1. Manufacturer:
 - a. Fry Reglet Corporation; www.fryreglet.com.
 - b. Substitutions: Section 01 6000. Acceptance is subject to compliance with specified design criteria, as evidenced by submittal of specified product data.
 - 2. Narrow V-screeds for horizontal soffits: Profiles as indicated on the Drawings.
 - 3. Stress Relief for Expansion and Control Joints: WLPDIA Detail 40 stress relief control joints, as dimensioned on the Drawings.
 - 4. Expansion screeds shall be 2-piece split plaster channel type equal to Fry Reglet PCS-75-25 2-PC.
 - a. Expansion screeds and vent screeds: Provide with nonstaining strippable tape or other suitable protective material to prevent plugging of perforations.
 - 5. Provide factory fabricated channel screed connector clips for alignment of intersections and splices.
 - 6. Clear Anodized Finish: Architectural 200R1 medium etch (AA-M32c10A21), clear color.

2.07 MISCELLANEOUS MATERIALS

- A. Water for Mixing: Potable and free of substances capable of affecting plaster set or of damaging plaster, lath, or accessories.
- B. Base Coat Fiber Reinforcing: Propex Concrete Systems, www.fibermesh.com, "Fibercast 500®"; 100% virgin polypropylene, fibers containing no reprocessed olefin materials and specifically manufactured for use as cementitious micro-reinforcement; ASTM C 1116, Type III 4.1.3, performance level 1. and ACI 524R-93. Detergent admixtures or clay to aid in pumping plaster will not be permitted.
- C. Crack Limitation Membrane: Resin coated, open weave, glass fiber mesh treated for compatibility with base coat material; weight: 4.5 oz./square yard minimum weight.
- D. Bonding Compound: ASTM C 932.
- E. Wire: ASTM A 641/A 641M, Class 1 zinc coating, soft temper, not less than 0.0475 -inch (1.21-mm) diameter, unless otherwise indicated.

2.08 SEALANT

- A. Single-Component, Nonsag, Neutral-Curing Silicone Joint Sealant: ASTM C 920, Type S, Grade NS, Class 100/50, for Use NT, complying with requirements of related Section 07 9005. Type as recommended by wall finish manufacturer for conditions indicated, and as required to maintain single-source warranty continuity.
 - 1. Color: As selected by Architect from manufacturer's standards.

2.09 PLASTER MIXES

- A. General: Comply with ASTM C 926 for applications indicated.
- B. Base Coat: BMI 690 basecoat, is a pre-blended product and therefore can be mixed in a continuous mixer or a mechanical plaster mixer.
- C. Mix per manufacturer instructions for three minutes, but never more than five minutes, Do NOT over mix.
- D. Traditional application or scratch and brown coat, double back method of application, or single pass of basecoats 3/4 inch - 7/8 inch in thickness is acceptable based on BMI Products ICC-ES Report ESR 2535.
- E. Protect mixtures from freezing, frost, contamination, and excessive evaporation.
- F. Do not retemper mixes after initial set has occurred.

PART 3 EXECUTION

3.01 EXAMINATION

- A. Examine substrates and conditions, with Installer present, for compliance with requirements for installation tolerances and other conditions affecting performance of the Work.
- B. Proceed with installation only after unsatisfactory conditions have been corrected.
- C. Framed Substrates: Verify that sheathing, weather barriers, continuous insulation, building papers and flashings specified in related sections are complete and ready to receive work of this section.
- D. Concrete: Verify surfaces are flat, honeycomb are filled flush, and surfaces are ready to receive work of this section. Verify no bituminous, water repellent, or form release agents exist on concrete surface that are detrimental to plaster bond.
- E. Mechanical and Electrical: Verify services within walls have been tested and accepted.

3.02 PREPARATION

- A. Protect adjacent work from soiling, spattering, moisture deterioration, and other harmful effects caused by plastering.
- B. Prepare smooth, solid substrates for plaster according to ASTM C 926.

3.03 INSTALLATION, GENERAL

- A. Fire-Resistance-Rated Assemblies: Install components according to requirements for design designations from listing organization and publication indicated on Drawings.

3.04 LATHING

- A. Metal Lath: Install according to ASTM C 1063. Fasten securely in place.
- B. General: Comply with CBC Table 2507.2 and the following;
 - 1. Install metal lath taut, using self furring fasteners, with long dimension perpendicular to supports, over sheathing and water-resistive barrier at walls and over ceiling framing at soffits, as indicated.
 - 2. Attach at maximum 6 -inch intervals conforming to requirements of ASTM C1063.
 - a. Use wire ties or screws at metal framing and powder driven wide-shouldered forced entry fasteners at solid metal backing.
 - b. All fasteners shall penetrate into structural support.
 - c. Use furring nails and hook staples at wood framing.
 - 3. Lap sides not less than 1/2 -inch and ends not less than 1 -inch. Lap wire fabric not less than one mesh at sides and ends or 1 -inch, whichever is greater. Lap rib lath at sides by nesting outside ribs. Stagger ends to differing supports and lap.
 - 4. Where solid backing is not provided, securely tie ends of lapped sheets not occurring over supports with minimum 18-gauge tie wire.
 - 5. Reinforce internal and external corners with lath.
 - a. Continuously reinforce internal angles with corner mesh, return metal lath 3 -inches from corner to form the angle reinforcement; Fasten only at perimeter edges.
 - 6. Insert lath as far as possible into reentrant space of metal frames, and notch to pass around jamb anchors.
- C. Horizontal Surfaces: Install as specified for vertical surfaces except attach ribbed lath to horizontal supports with wire ties or hook staples as described in CBC 2507.3 in addition to the methods described in Table 2507.2.

3.05 ACCESSORY INSTALLATION

- A. Fasten accessories in place at both ends and at a maximum of 12 -inches on center along sides, and as required to prevent dislodging or misalignment by subsequent operations.
- B. Install accessories to provide required depth of plaster and to bring plaster surface to required plane.
- C. Set accessories straight, plumb, level and true to line. Shim as required to proper grounds. Align joints with concealed splices or tie plates. Trim or cope screeds and accessories to coordinate, lap or be lapped with flashings and work provided by other sections. Ensure all laps of accessories and flashings weather to exterior and away from flow direction of water behind the plaster.
- D. Neatly miter or cope corners and intersections of accessories to fit exposed edges. Make tight hairline joints.
- E. Butt and align accessory joints at ends and intersections and seal. Vertical accessories shall run continuous, interrupting horizontal accessories.

- F. Continuously reinforce angles and fasten only at perimeter edges. Connect lengths of accessories as recommended by the manufacturer to assure a continuous line.
- G. Extend accessories into niches and recesses, around interior and exterior wall corners, and around all sides of columns and similar building elements. Continue control joint patterns and molding alignments on walls of arcades, passages and all similar locations to match or extend those shown on exterior elevations, whether or not individual conditions are specifically shown, noted or elevated.
 - 1. Locations and extents indicated on drawings are the minimum required. If joints shown on the drawings are fewer, recommend joints as specified here and request confirmation of layout by Architect.
- H. Weep Screeds - Foundation: Provide typically and as indicated.
 - 1. Install foundation weep screeds at all bottom of walls to receive lath and plaster.
 - 2. Place the bottom edge of the foundation weep screed not less than 1 -inch (25 mm) below the joint formed by the foundation and framing.
 - 3. The nose of the screed shall be placed not less than 4 -inches (102 mm) above raw earth.
 - 4. The nose of the screed shall be placed not less than 2 -inches (51 mm) above paved surfaces.
 - 5. The weather resistant barrier (Building Papers) and lath shall entirely cover the vertical attachment flange and terminate at the top edge of the nose or ground flange.
- I. Beads and Reinforcements:
 - 1. Use single length of metal beads wherever length of run does not exceed longest standard stock length available.
 - 2. Provide casing beads at terminations of plaster finish and at the following locations. Butt and align ends. Secure rigidly in place:
 - a. Where plaster abuts another material or dissimilar construction.
 - b. At perimeter of openings where edges of plaster will not be concealed by other work
 - c. Locations indicated and where an exposed plaster edge would occur otherwise.
 - 3. Corner Beads: Install for full length of outside corners, fastened at outer edges only.
 - 4. Cornerite Reinforcements: Install at inside corners, except where lath is carried around corners at least 3 -inches (75 mm).
 - 5. Strip Lath Reinforcement:
 - a. Reinforce corners of openings diagonally with 9 -inch by 24 -inch strips of metal lath, tied to reinforcement.
 - b. Place 4-inch wide strips of metal lath centered over junctions of dissimilar backing materials. Secure rigidly in place.
 - 6. Stress Relief Joints: Space joints as indicated on Contract Drawings. Locations and extents indicated on drawings are the minimum required. If joints shown on the drawings are fewer than minimum required by this specification, recommend joints as specified here and request confirmation of layout by Architect.
 - a. Coordinate joint placement to preserve visual alignment with other work acceptable to Architect.
 - b. Cut and separate reinforcement behind expansion and control joints.
 - c. Use double casing bead spaced 1/4-inch (6 mm) apart to form joint.

3.06 PREPARATION - SOLID BASES

- A. Dampen masonry surfaces to reduce excessive suction.
- B. Clean concrete surfaces of foreign matter. Clean surfaces using acid solutions, solvents, or detergents. Wash surfaces with clean water.
- C. Roughen smooth concrete surfaces and apply bonding agent in accordance with manufacturer's instructions.

3.07 PLASTERING

- A. General: Comply with ASTM C 926.
 - 1. Do not deviate more than plus or minus 1/4 inch in 10 feet (6 mm in 3 m) from a true plane in finished plaster surfaces when measured by a 10-foot (3-m) straightedge placed on surface.
 - 2. Finish plaster flush with metal frames and other built-in metal items or accessories that act as a plaster ground unless otherwise indicated. Where casing bead does not terminate plaster at metal frame, cut base coat free from metal frame before plaster sets and groove finish coat at junctures with metal.
 - 3. Provide plaster surfaces that are ready to receive field-applied finishes indicated.
- B. Apply plaster in accordance with manufacturer's instructions, and ICC-ES Report.
- C. Three-Coat Application Over Metal Lath per manufacturer unstructions, or for field-mixed plaster:
 - 1. Apply first coat to a nominal thickness of 3/8 inch. Apply plaster scratch coat to embed lath completely so that no lath is visible. Scratch or score vertical surfaces horizontally at even intervals for mechanical key.
 - 2. Apply second coat to a nominal thickness of 3/8 inch once the first coat is sufficiently rigid to accept the application without being disturbed. Apply evenly, using a rod, darby or other straightedge, bring surface t to a true, even plane, flush with plaster grounds.
 - 3. Float surface with a wood or hard rubber float to promote densification and ensure a surface with adequate "tooth" receptive to bonding of the finish coat.
 - 4. Apply finish coat to a nominal thickness of 1/8 inch per manufacturer instructions.
- D. Three-Coat Application Over Solid Bases:
 - 1. Bonding Compound: Apply on unit masonry and concrete substrates for direct application of plaster.
 - 2. Apply first coat to a nominal thickness of 1/4 inch.
 - 3. Apply second coat to a nominal thickness of 1/4 inch.
 - 4. Apply finish coat to a nominal thickness of 1/8 inch.
- E. Curing: Base requires adequate moisture to allow continuous hydration of the cement.
 - 1. Minimum four (4) days of moist curing shall be provided.
 - 2. Provide additional moist curing to conform to code requirements, manufacturer recommendations, local practices and climatic conditions and as otherwise required to provide acceptable substrate for finish coat.
 - 3. Base coat shall be allowed to cure for a minimum of 7 days prior to coating with primer and textured finish.
- F. Reinforced Leveling Coat:
 - 1. Ensure that the surface of the wall is cured, clean, dry and free of efflorescence, oil or other contaminants that would impair adhesion.
 - 2. Apply polymer-modified base coat mixture in continuous layer approximately 1/16 -1/8 inch thick.
 - 3. Apply a layer of Reinforcing Mesh into the wet mixture and trowel smooth until mesh is fully embedded. Lap adjoining pieces of mesh 2-1/2 inches minimum and as described in the manufacturer's written instructions and technical bulletins.
 - 4. Cure for a minimum of 24 hours, until dry, or longer as required by weather conditions.
- G. Primer Application:
 - 1. Ensure that the surface of the wall is cured, clean, dry and free of efflorescence, oil or other contaminants that would impair adhesion.
 - 2. Primer color shall closely match that of the selected finish.
 - 3. Stir to a smooth homogeneous consistency and apply to the wall using a roller, brush or airless spray equipment. Refer to manufacturer's published data sheet for more complete instructions.

4. Allow to completely dry.
- H. Finish Application:
1. Ensure that the surface of the wall is clean, dry and free of any contaminants that may impair the adhesion of surface finish.
 2. Spray or trowel apply textured finish to dried primer.
 3. Apply finish to natural breaks to avoid visible cold joints.
 4. Always work the shady side of the wall or provide temporary shading to avoid application in direct sunlight.
 5. Apply in accordance with manufacturer directions for the specific finish and texture being used.
- I. Concealed Exterior Plaster: Where plaster application is used as a base for adhered finishes, omit finish coat.
- J. Concealed Interior Plaster:
1. Where plaster application is concealed behind built-in cabinets, similar furnishings, and equipment, apply finish coat.
 2. Where plaster application is concealed above suspended ceilings and in similar locations, omit finish coat.
 3. Where tile or other finishes are adhered to plaster, verify that plaster work specified complies with requirements for setting materials.
 4. Where plaster application is used as a base for adhesive application of tile and similar finishes, omit finish coat.

3.08 PLASTER REPAIRS

- A. Repair or replace work to eliminate cracks, dents, blisters, buckles, crazing and check cracking, dry outs, efflorescence, sweat outs, and similar defects and where bond to substrate has failed.
- B. Remove and replace material that is stained, damaged or that does not match specified finishes. Provide new matching finish as specified, without evidence of replacement.

3.09 CLEANING AND PROTECTION

- A. Clean installed surfaces in accordance with manufacturer's instructions; do not clean surfaces with products not specified in manufacturer's instructions. Clean as work progresses, remove residue without delay.
- B. Protect metal surfaces and plumbing fixtures. Flush surfaces with clean water before and after cleaning.
- C. Protect finished work from damage until acceptance by Owner.

END OF SECTION

SECTION 09 3000

TILING

PART 1 GENERAL

1.01 SECTION INCLUDES

- A. Tile: Ceramic tile for wall and interior applications.
- B. Cementitious backer board as tile substrate.
- C. Coated glass mat backer board as tile substrate.
- D. Ceramic trim.

1.02 RELATED REQUIREMENTS

- A. Section 01 6116 - Volatile Organic Compound (VOC) Content Restrictions.
- B. Section 06 1000 - Rough Carpentry: Wood frame substrates.
- C. Section 08 3100 - Access Doors.
- D. Pertinent Sections specifying work penetrating tile surfaces.

1.03 REFERENCE STANDARDS

- A. ANSI A108/A118/A136.1 - American National Standard Specifications for the Installation of Ceramic Tile (Compendium).
 - 1. ANSI A108.1a - American National Standard Specifications for Installation of Ceramic Tile in the Wet-Set Method, with Portland Cement Mortar.
 - 2. ANSI A108.1b - American National Standard Specifications for Installation of Ceramic Tile on a Cured Portland Cement Mortar Setting Bed with Dry-Set or Latex-Portland Cement Mortar.
 - 3. ANSI A108.1c - Specifications for Contractors Option: Installation of Ceramic Tile in the Wet-Set Method with Portland Cement Mortar or Installation of Ceramic Tile on a Cured Portland Cement Mortar Bed with Dry-Set or Latex-Portland Cement.
 - 4. ANSI A108.4 - American National Standard Specifications for Installation of Ceramic Tile with Organic Adhesives or Water Cleanable Tile-Setting Epoxy Adhesive.
 - 5. ANSI A108.5 - American National Standard Specifications for Installation of Ceramic Tile with Dry-Set Portland Cement Mortar or Latex-Portland Cement Mortar.
 - 6. ANSI A108.6 - American National Standard Specifications for Installation of Ceramic Tile with Chemical Resistant, Water Cleanable Tile-Setting and -Grouting Epoxy.
 - 7. ANSI A108.8 - American National Standard Specifications for Installation of Ceramic Tile with Chemical Resistant Furan Resin Mortar and Grout.
 - 8. ANSI A108.9 - American National Standard Specifications for Installation of Ceramic Tile with Modified Epoxy Emulsion Mortar/Grout.
 - 9. ANSI A108.10 - American National Standard Specifications for Installation of Grout in Tilework.
 - 10. ANSI A108.11 - American National Standard Specifications for Interior Installation of Cementitious Backer Units.
 - 11. ANSI A108.11-SystemDeleted - American National Standard for Interior Installation of Cementitious Backer Units.
 - 12. ANSI A118.3 - American National Standard Specifications for Chemical Resistant, Water Cleanable Tile-Setting and -Grouting Epoxy and Water Cleanable Tile-Setting Epoxy Adhesive.
 - 13. ANSI A118.9 - American National Standard Specifications for Test Methods and Specifications for Cementitious Backer Units.
 - 14. ANSI A118.9>ANSI A108/A118/A136.1 - American National Standard Specifications for Test Methods and Specifications for Cementitious Backer Units.

15. ASTM C373 - Standard Test Method for Water Absorption, Bulk Density, Apparent Porosity, and Apparent Specific Gravity of Fired Whiteware Products, Ceramic Tiles, and Glass Tiles.
 16. American National Standard Specifications for Polymer Modified Cement Grouts for Tile Installation A118.7
 17. American National Standard Specifications for Load Bearing, Bonded, Waterproof Membranes for Thin-set Ceramic Tile and Dimension Stone Installation A118.10
- B. Manufacturer's specifications and recommendations for mounting in exterior or wet areas.
 - C. ASTM C1178/C1178M - Standard Specification for Coated Glass Mat Water-Resistant Gypsum Backing Panel.
 - D. California Code of Regulations, Title 24, Part 2, California Building Code (CBC), International Building Code.
 - E. California Code of Regulations, Title 24, Part 11 California Green Building Standards Code, "CAL-Green".
 - F. Division of the State Architect Interpretation of Regulations (IR) 23-3: Approved Alternate for Toilet Room Curb, latest edition.
 - G. TCNA (HB) - Handbook for Ceramic, Glass, and Stone Tile Installation.

1.04 DEFINITIONS

- A. General: Definitions in the ANSI A108 series of tile installation standards and in ANSI A137.1 apply to Work of this Section unless otherwise specified.
 1. ANSI A108 Series: ANSI A108.01, ANSI A108.02, ANSI A108.1A, ANSI A108.1B, ANSI A108.1C, ANSI A108.4, ANSI A108.5, ANSI A108.6, ANSI A108.8, ANSI A108.9, ANSI A108.10, ANSI A108.11, ANSI A108.12, ANSI A108.13, ANSI A108.14, ANSI A108.15, ANSI A108.16, and ANSI A108.17, which are contained in its "Specifications for Installation of Ceramic Tile."
- B. Module Size: Actual tile size plus joint width indicated.
- C. Face Size: Actual tile size, excluding spacer lugs.
- D. Large Format Tile: Tile that is greater than 15 inches (381 mm) in width or length.
- E. Wet Area: Includes tile surfaces that are either soaked, saturated, or regularly and frequently subjected to moisture such as tub enclosures, showers, swimming pools, commercial kitchens and exterior areas.

1.05 SUBMITTALS

- A. See Section 01 3300 - Submittal Procedures.
- B. Product Data: Provide manufacturers' data sheets on tile, mortar, grout, grout sealer and accessories. Include instructions for using grouts and adhesives.
 1. Identify additional requirements and areas where manufacturer's installation instructions differ from TCNA documents.
- C. CAL-GREEN Submittals:
 1. Product Data - VOC Limits: For adhesives, sealants, fillers, primers and coatings, documentation including printed statement of VOC contents, comply with limits specified in related section.
 2. Product Data - Low/No-VOC Paints, Coatings and Tile Sealers. Provide certification that all primers and coatings meet VOC emission limits specified in in related section. List manufacturer, brand, application, type (flat or non-flat), number of gallon, and the VOC emissions in

- grams/liter. Include MSDS and product data sheet indicating VOC limits for each product provided.
- D. Shop Drawings: Indicate tile layout, patterns, color arrangement, perimeter conditions, junctions with dissimilar materials, control and expansion joints, thresholds, ceramic accessories, and setting details.
 - E. Samples for Selection:
 - 1. Two manufacturer color charts consisting of actual tiles or sections of tile showing full range of standard and custom colors, textures and patterns available for each type of tile indicated.
 - 2. Grout and accessories requiring color selection.
 - F. Installation Instructions: Manufacturer's printed instructions for each product.
 - G. Manufacturer's Certificate: Certify that products meet or exceed specified requirements.
 - H. Maintenance Data: Include recommended cleaning methods, cleaning materials, and stain removal methods.
 - I. Maintenance Materials: Furnish the following for Owner's use in maintenance of project.
 - 1. See Section 01 6000 - Product Requirements, for additional provisions.
 - 2. Extra Tile: 1 percent of each size, color, and surface finish combination, but not less than 10 square feet of each type.
 - 3. Leftover Materials: all leftover materials not installed.

1.06 MOCK-UP

- A. See Section 01 4000 - Quality Control, for general requirements for mock-up.
- B. Construct tile mock-up in a mutually accepted location, incorporating all components specified for the location. Minimum size 8 feet long by full height of indicated tile extent.
- C. Approved mock-up may remain as part of the Work.

1.07 DELIVERY, STORAGE, AND HANDLING

- A. Deliver and store packaged materials in original containers with seals unbroken and labels intact until time of use. Prevent damage or contamination to materials by water, freezing, foreign matter or other causes.
 - 1. Provide heated and dry storage facilities on site.
- B. Package labeling in accordance with ANSI A137.1. Retain labels and packaging until disposal is authorized by Architect.
- C. Protect adhesives from freezing or overheating in accordance with manufacturer's instructions. Do not use frozen materials.
- D. Deliver and store materials on site at least 24 hours before work begins.

1.08 FIELD CONDITIONS

- A. Maintain environmental conditions and protect work during and after installation to comply with referenced standards and manufacturer's printed recommendations.

PART 2 PRODUCTS

2.01 DESIGN REQUIREMENTS

- A. VOC Limits for adhesives, sealants, fillers, primers and coatings . Comply with limits specified in related section.

- B. Slip Resistance: For tile installed on walking surfaces, stair treads and landings, provide products with the following values as determined by testing identical products per ANSI A137.1-2012, Section 9.6
 - 1. Method: Dynamic Coefficient of Friction DCOF AcuTest method, wet test using 0.05 percent sodium lauryl sulfate solution.
 - 2. Application: Level interior flooring surface
 - 3. Tested value: 0.42 or greater
- C. Expansion Joints: In accordance with EJ-171 of the Tile Installation Handbook. Provide at expansion joints in the backing materials, cold joints in concrete substrate or where backing materials change.
 - 1. Exterior Work and Interior Wet Locations: Provide on all surfaces maximum 12-feet on center in both axes.
- D. Wainscots: Make top course full uncut tile. Extend wainscot to higher elevation by adding horizontal courses of tile as required to completely surround access panels, switch or outlet covers with finished tile. Do not permit these items penetrating tile surfaces to split the boundary of the tile surface.

2.02 TILE

- A. General:
 - 1. Field and accent tiles shall be of the same caliper.
 - 2. Each room with tile in each building shall have a separate color scheme.
 - 3. Field colors to be selected from price group 2, accent colors to be selected from premium price groups. Allow for one accent color to be selected from price groups 3 or 4, minimum per tile type at each separate location unless noted otherwise below.
- B. Manufacturers: All products by the same manufacturer.
 - 1. American Olean Corporation: www.americanolean.com/#sle.
 - 2. Dal-Tile Corporation: www.daltile.com/#sle.
 - 3. Interceramic: www.interceramicusa.com.
 - 4. Roca Tile USA: www.rocatilegroup.com
 - 5. Substitutions: See Section 01 6000 - Product Requirements.
- C. Glazed Wall Tile: ANSI A137.1, standard grade.
 - 1. Moisture Absorption: 7.0 to 20.0 percent as tested in accordance with ASTM C373.
 - 2. Size: 4-1/4 by 4-1/4 inch, nominal.
 - 3. Edges: Cushioned.
 - 4. Surface Finish: High gloss.
 - 5. Color: Field colors To be selected from manufacturer's standard range Price Group 2, and two accent colors selected from premium Price Groups.
 - 6. Pattern: As indicated; if none indicated, allow for field and two accent colors (three colors) and request pattern.
 - 7. Trim Units: Matching bead, bullnose, cove, and base shapes in sizes coordinated with field tile.

2.03 TRIM AND ACCESSORIES

- A. Ceramic Trim: Matching bullnose, double bullnose, cove base, and cove ceramic shapes in sizes coordinated with field tile.
 - 1. Applications:
 - a. Open Edges: Bullnose.
 - b. Inside Corners: Coved.
 - c. Floor to Wall Joints: Cove base.
 - 2. Manufacturers: Same as for tile.

2.04 SETTING MATERIALS

- A. Acceptable Manufacturers:
 - 1. Custom Building Products; 13001 Seal Beach Blvd., Seal Beach, CA 90740, (800) 272-8786 John Gallup - (209) 518-1153 johng@cbpmail.net, www.custombuildingproducts.com
 - 2. LATICRETE International, Inc; www.laticrete.com.
 - 3. Mapei Corporation; www.mapei.com..
 - 4. Substitutions: See Section 01 6000 - Product Requirements.
- B. Source Limitations: Provide tile grout, setting materials, additives, and factory-prepared dry-set mortars and surface preparation materials, waterproofing and crack isolation membranes, and self-leveling underlayments from the same manufacturer.
- C. Epoxy Adhesive and Mortar Bond Coat: ANSI A118.3.
 - 1. Applications: All locations.
 - 2. Products:
 - a. Custom Building Products; EBMLite - Lightweight Epoxy Bonding Mortar or CEGLite - Lightweight Commercial Epoxy Grout - Setting and Grouting Epoxy www.custombuildingproducts.com.
 - b. LATICRETE International, Inc; LATICRETE LATAPOXY 300 Adhesive: www.laticrete.com/#sle.
 - c. Substitutions: See Section 01 6000 - Product Requirements.
- D. Mortar Bed Materials: Pre-packaged mix of Portland cement, sand, latex additive, and water.
 - 1. Products:
 - a. Custom Building Products; Thick Bed Bedding Mortar: www.custombuildingproducts.com.
 - b. LATICRETE International, Inc; LATICRETE 3701 Fortified Mortar Bed: www.laticrete.com/#sle.
 - c. Mapei; 4 To 1 Mud Bed Mix: www.mapei.com.
 - d. Substitutions: See Section 01 6000 - Product Requirements.

2.05 GROUTS

- A. Manufacturers:
 - 1. Custom Building Products: www.custombuildingproducts.com
 - 2. LATICRETE International, Inc; LATICRETE PERMACOLOR Grout: www.laticrete.com/#sle.
 - 3. Mapei Corporation: www.mapei.com.
 - 4. Substitutions: See Section 01 6000 - Product Requirements.
- B. Epoxy Grout: ANSI A118.3 chemical resistant and water-cleanable epoxy grout with a VOC content of 65 g/L or less and a System Warranty of Twenty-Five Years.
 - 1. Applications: Where indicated.
 - 2. Color(s): As selected by Architect from manufacturer's full line.
 - 3. Products:
 - a. Custom Building Products; CEGLite Lightweight Commercial Epoxy Grout.
 - b. LATICRETE International, Inc; LATICRETE SPECTRALOCK PRO Premium Grout: www.laticrete.com/#sle.
 - c. Mapei; Kerapoxy.

2.06 MAINTENANCE MATERIALS

- A. Tile Sealant: Gunnable, silicone, siliconized acrylic, or urethane sealant; moisture and mildew resistant type.
 - 1. Applications: Between tile and plumbing fixtures.
 - 2. Color(s): As selected by Architect from manufacturer's full line.

3. Products:
 - a. LATICRETE International, Inc; LATICRETE LATASIL: www.laticrete.com/#sle.
 - b. ProSpec, an Oldcastle brand; ProColor Advantage Caulk: www.prospec.com.
 - c. Substitutions: See Section 01 6000 - Product Requirements.
- B. Grout Sealer: Liquid-applied, moisture and stain protection for existing or new Portland cement grout that does not change color or appearance of grout. Colorless, no-sheen, water-based penetrating slip and stain-resistant sealer, not affecting color or physical properties of surfaces as recommended by tile manufacturers..
 1. Composition: Water-based colorless silicone.
 2. Products:
 - a. Aqua Mix® Sealers Choice® Gold as manufactured by CUSTOM Building Products, www.custombuildingproducts.com
 - b. DuPont™ StoneTech® Professional Impregnator Pro® Sealer as manufactured by Dupont, www2.dupont.com as supplied by Laticrete, www.laticrete.com.
 - c. MAPEI Corporation, www.mapei.com, Ultracare™ line of products.
 - d. Miracle, www.miraclesealants.com, Impregnator 511 (Original).
 - e. Substitutions: See Section 01 6000 - Product Requirements.

2.07 ACCESSORY MATERIALS

- A. Cleavage Membrane Under Thick Mortar Bed:
 1. Material: No. 15 asphalt saturated felt.
- B. Reinforcing Mesh: 2 by 2 inch size weave of 16/16 wire size; welded fabric, galvanized.
- C. Membrane at Walls:
 1. Material: 4 mil thick polyethylene film.
- D. Backer Board: Cementitious type complying with ANSI A118.9; high density, glass fiber reinforced, 1/2 inch thick; 2 inch wide coated glass fiber tape for joints and corners.
- E. Backer Board: Coated glass mat type complying with ASTM C1178/C1178M; inorganic fiberglass mat on both surfaces and integral acrylic coating vapor retarder.
- F. Mesh Tape: 2 inch wide self-adhesive fiberglass mesh tape.
- G. Cleaning solutions
 1. Glazed tile: Acid or pH-neutral solutions as approved by the grout and tile manufacturers.
 2. Unglazed Tile: Clean with pH-neutral solutions.
- H. Tile Polish: As recommend by tile and grout manufacturers.

2.08 MIXES

- A. Proportion and mix materials in accordance with manufacturer's instructions and applicable ANSI standards.

PART 3 EXECUTION

3.01 EXAMINATION

- A. Examine, with installer present, surfaces to receive tile work and conditions under which tile will be installed. Do not proceed with tile work until surfaces and conditions comply with requirements indicated in referenced tile installation standards and manufacturer's printed instructions. Prepared substrates to be in accordance with ANSI A108, A3.1 and Tile Council of North America (TCNA) recommendations.

- B. Verify that sub-floor surfaces are smooth and flat within the tolerances specified for that type of work and are ready to receive tile.
- C. Verify that wall surfaces are smooth and flat within the tolerances specified for that type of work, are dust-free, and are ready to receive tile.
- D. Verify that sub-floor surfaces are dust-free and free of substances that could impair bonding of setting materials to sub-floor surfaces.
- E. Verify that required floor-mounted utilities are in correct location.

3.02 PREPARATION

- A. Protect surrounding work from damage.
- B. Vacuum clean surfaces and damp clean.
- C. Seal substrate surface cracks with filler. Level existing substrate surfaces to acceptable flatness tolerances. Shim wood framing substrates to acceptable flatness tolerances.
- D. Install backer board in accordance with ANSI A108.11 and board manufacturer's instructions. Tape joints and corners, cover with skim coat of setting material to a feather edge.
- E. Blend tile before installation and ensure that variations are uniform in each location.

3.03 INSTALLATION - GENERAL

- A. Install tile and thresholds and grout in accordance with applicable requirements of ANSI A108.1 through A108.13, manufacturer's instructions, and TCNA Handbook recommendations.
- B. Lay tile to pattern indicated. Do not interrupt tile pattern through openings.
 - 1. Align joints when adjoining tile on floor, base, walls and trim are same size.
 - 2. Layout tile work and center tile fields in both directions in each space or on each wall area.
 - 3. Provide minimum 1/2 tile at field edges.
 - 4. Adjust to minimize tile cutting. Provide uniform joint widths.
- C. Place thresholds at exposed tile edges.
- D. Cut and fit tile to penetrations through tile, leaving sealant joint space. Form corners and bases neatly. Align floor joints.
- E. Place tile joints uniform in width, subject to variance in tolerance allowed in tile size. Make grout joints without voids, cracks, excess mortar or excess grout, or too little grout.
- F. Extend tile work into recesses and under or behind equipment and fixtures, to form a complete covering without interruptions. Terminate work neatly at obstructions, edges and corners without disrupting pattern or joint alignments.
- G. Form internal angles square and external angles bullnosed.
- H. Accurately form intersections and returns.
 - 1. Perform cutting and drilling of tile without marring visible surfaces.
 - 2. Carefully grind cut edges of tile abutting trim, finish or built-in items to produce straight aligned joints.
 - 3. Fit tile closely to electrical outlets, piping, fixtures and other penetrations so that plates, collars, or covers overlap tile.
 - 4. Terminate tile at center line of doors, unless otherwise indicated.
 - 5. Ensure that joints are symmetrical and that tile surfaces are plumb, true to line, and parallel to the room axis

- I. Sound tile after setting. Replace hollow sounding units.
- J. Install expansion and control joints in accordance with TCNA method EJ171.
- K. Keep control and expansion joints free of mortar, grout, and adhesive.
- L. In areas with floor drains, maintain design floor elevation at walls; slope surfaces uniformly to drains at 1/8 inch per foot nominal without retention of water or ponding.
- M. Prior to grouting, allow installation to completely cure; minimum of 48 hours.
- N. Grout tile joints. Conform to requirements of ANSI A108.10.
- O. At changes in plane and tile-to-tile control joints, use tile sealant instead of grout, with either bond breaker tape or backer rod as appropriate to prevent three-sided bonding.
- P. Apply sealant to junction of tile and dissimilar materials and junction of dissimilar planes.
 - 1. Seal joint between wainscots and fixtures; seal around pipes penetrating wainscots. Tool exposed sealant joints to a uniformly smooth surface without laps, sags or depressions.
- Q. Grout Sealing: Test sealer before application and assure that sealer will not stain grout.
 - 1. Test sealer before application and assure that sealer will not stain grout.
 - 2. Seal joints between wainscots and fixtures, seal around pipes penetrating wainscots.
 - 3. Tool exposed sealant joints to uniform smooth surface without laps, sags or depressions.
- R. Cracked, split, chipped, misaligned or broken tiles will not be accepted in finished work.

3.04 INSTALLATION - WALL TILE

- A. Over cementitious backer units on studs, install in accordance with TCNA Handbook Method W244C, using membrane at toilet rooms.
- B. Over coated glass mat backer board on studs, install in accordance with TCNA Handbook Method W245, using membrane at toilet rooms.

3.05 GROUTING

- A. Grout joints in accordance with manufacturer's instructions and ANSI A108.10.
- B. Clean sanding water, dust, and foreign substances from joints to be grouted.
- C. Clean and dry tile surfaces.
- D. After grouting, remove all grout residue promptly.

3.06 TOLERANCES

- A. Variation from Plumb: For vertical joints, external corners, and other conspicuous lines, do not exceed 1/8 inch in 10 feet.
- B. Variation in Level: For horizontal joints and other conspicuous lines, do not exceed 1/4 inch in 20 feet (6 mm in 6 m), or 1/2 -inch (12 mm) maximum.
- C. Maximum Variation of Surface Flatness For Tile Floors: 1/8 inch in ten feet, non-cumulative, free of ponding, all water flows to drains.
- D. Maximum Variation of Surface Flatness For Tile Walls: 1/8 inch in ten feet, non-cumulative.
- E. Variation in Plane between Adjacent Units (Lipping): Do not exceed the following differences between faces of adjacent units as measured from a straightedge parallel to stone tiled surface:
 - 1. Units with Polished Faces: 1/64 -inch (0.4 mm).

2. Units with Honed Faces: 1/32 -inch (0.8 mm).
 3. Units with Sand-Rubbed Faces: 1/32 -inch (0.8 mm).
 4. Units with Thermal-Finished Faces: Depth of thermal finish or 3/16 -inch (5 mm), whichever is less.
 5. Units with Natural-Cleft Faces: Depth of natural-cleft finish or 3/16 -inch (5 mm), whichever is less.
- F. Variation in Joint Width: Do not vary joint thickness more than 1/16 -inch (1.6 mm) or one-fourth of nominal joint width, whichever is less.
- G. Correct surfaces if tolerances are not as specified.
- H. Correct defects by removal and replacement of the defective work. Areas requiring corrective work will be identified. Re-measure corrected areas for compliance.

3.07 ADJUSTING AND CLEANING

- A. Remove and replace tile that is damaged or that does not match adjoining tile. Provide new matching units, installed as specified and in a manner to eliminate evidence of replacement.
- B. Allow grout to cure 14 days before cleaning. Clean all ceramic tile surfaces so they are free of foreign matter. Flush surface with clean water before and after cleaning.
- C. Clean tile and grout surfaces.
- D. Protect metal surfaces, cast iron and vitreous plumbing fixtures from effects of acid cleaning.
- E. Before final inspection, remove protective coverings and rinse neutral cleaner from tile surfaces.

3.08 PROTECTION

- A. Do not permit traffic over finished floor surface for 7 days after installation.
- B. Walls: Protect from impact, vibration and heavy hammering on adjacent and opposite walls for at least 14 days after installation, unless manufacturer's instructions allow a shorter period.
- C. Protect from food products and chemicals which can cause staining for at least 14 days.
- D. Protect from freezing and total water immersion for at least 21 days after installation.

END OF SECTION

**SECTION 09 6500
RESILIENT FLOORING**

PART 1 GENERAL

1.01 SECTION INCLUDES

- A. Resilient base.
- B. Installation accessories.

1.02 RELATED REQUIREMENTS

- A. Section 01 6116 - Volatile Organic Compound (VOC) Content Restrictions.
- B. Section 01 8113 - Sustainable Design Requirements.

1.03 REFERENCE STANDARDS

- A. ASTM F1861 - Standard Specification for Resilient Wall Base.
- B. California Code of Regulations, Title 24, Part 2, California Building Code (CBC), International Building Code.
- C. California Code of Regulations, Title 24, Part 11 California Green Building Standards Code, "CAL-Green".

1.04 SUBMITTALS

- A. See Section 01 3300 - Submittals, for submittal procedures.
- B. Provide complete submittals at the same time as submittals for work in related sections to permit review of complete and integrated systems and assemblies.
- C. Product Data: Provide data on specified products, describing physical and performance characteristics; including sizes, patterns and colors available; and installation instructions.
- D. CAL-GREEN Submittals:
 - 1. Product Data - VOC Limits: For adhesives sealants, fillers, primers and coatings, documentation including printed statement of VOC contents, comply with limits specified in related section.
- E. Selection Samples: Submit manufacturer's complete set of color samples for Architect's initial selection.
- F. Verification Samples: Submit two samples, 4 by 4 inch in size illustrating color and pattern for each resilient flooring product specified.
- G. Maintenance Data: Include maintenance procedures, recommended maintenance materials, and suggested schedule for cleaning, stripping, and re-waxing.

1.05 DELIVERY, STORAGE, AND HANDLING

- A. Protect roll materials from damage by storing on end.

1.06 FIELD CONDITIONS

- A. Store materials for not less than 48 hours prior to installation in area of installation at a temperature of 70 degrees F to achieve temperature stability. Thereafter, maintain conditions above 55 degrees F.

1.07 EXTRA MATERIALS

- A. See Section 01 6000 - Product Requirements, for additional provisions.

- B. Provide 50 lineal feet of base material type and color specified.

PART 2 PRODUCTS

2.01 PERFORMANCE REQUIREMENTS

- A. VOC Limits for adhesives, sealants, fillers, primers and coatings . Comply with limits specified in related section.

2.02 RESILIENT BASE

- A. Base: Type TP, rubber, thermoplastic; top set Style B, Cove:
1. Manufacturers:
 - a. Burke Flooring: www.burkemercer.com.
 - b. Johnsonite, a Tarkett Company: www.johnsonite.com.
 - c. Roppe Corp: www.roppe.com.
 - d. Substitutions: See Section 01 6000 - Product Requirements.
 2. Critical Radiant Flux (CRF): Minimum 0.45 watt per square centimeter, when tested in accordance with ASTM E 648 or NFPA 253.
 3. Height: 4 inch.
 4. Thickness: 0.125 inch.
 5. Finish: Satin.
 6. Length: Roll.
 7. Color: To be selected by Architect from manufacturer's full range.
 8. Accessories: Premolded external corners and internal corners.

2.03 ACCESSORIES

- A. Filler for Coved Base: Plastic.

PART 3 EXECUTION

3.01 EXAMINATION

- A. Verify that wall surfaces are smooth and flat within the tolerances specified for that type of work, are dust-free, and are ready to receive resilient base.

3.02 PREPARATION

- A. Clean substrate.

3.03 Installation - General

- A. Install in accordance with manufacturer's written instructions.
- B. Spread only enough adhesive to permit installation of materials before initial set.
- C. Fit joints and butt seams tightly.
- D. Scribe flooring to walls, columns, cabinets, floor outlets, and other appurtenances to produce tight joints.

3.04 Installation - Resilient Base

- A. Fit joints tightly and make vertical. Maintain minimum dimension of 18 inches between joints.
- B. Miter internal corners. At external corners, use premolded units. At exposed ends, use premolded units.
- C. Install base on solid backing. Bond tightly to wall and floor surfaces.

- D. Scribe and fit to door frames and other interruptions.

3.05 CLEANING

- A. Remove excess adhesive from floor, base, and wall surfaces without damage.
- B. Clean in accordance with manufacturer's written instructions.

END OF SECTION

**SECTION 09 6566
RESILIENT ATHLETIC FLOORING**

PART 1 GENERAL

1.01 SECTION INCLUDES

- A. Rubber sheet flooring, adhesively installed.
- B. Accessories.

1.02 RELATED REQUIREMENTS

- A. Section 01 6116 - Volatile Organic Compound (VOC) Content Restrictions.
- B. Section 01 8113 - Sustainable Design Requirements.
- C. Section 03 3000 - Cast-in-Place Concrete: Restrictions on curing compounds for concrete slabs and floors.
- D. Pertinent sections specifying Concrete Floor Preparation, Concrete Floor Moisture Content & pH Testing and Water Vapor Emission Control Coating (Moisture Mitigation System).

1.03 REFERENCE STANDARDS

- A. ASTM D412 - Standard Test Methods for Vulcanized Rubber and Thermoplastic Elastomers--Tension.
- B. California Code of Regulations, Title 24, Part 2, California Building Code (CBC), International Building Code.
- C. California Code of Regulations, Title 24, Part 11 California Green Building Standards Code, "CAL-Green".

1.04 SUBMITTALS

- A. See Section 01 3300 - Submittals, for submittal procedures.
- B. Provide complete submittals at the same time as submittals for work in related sections to permit review of complete and integrated systems and assemblies.
- C. Product Data: Manufacturer's descriptive literature for specified materials and products; include documentation of conformance to specified requirements.
 - 1. Interior line paint data sheets.
 - 2. Product Manufacturer's written acceptance of curing compounds and water vapor control membranes provided under other sections.
- D. CAL-GREEN Submittals:
 - 1. Product Data - VOC Limits: For adhesives sealants, fillers, primers and coatings, documentation including printed statement of VOC contents, comply with limits specified in related section.
 - 2. Product Data - Resilient Flooring: Documentation from an independent testing agency indicating compliance with the FloorScore Standard, or evidence of listing on the RFCI FloorScore database, or evidence of listing on the CHPS Product Registry.
 - 3. Product Data - Low/No-VOC Paints and Coatings. Provide certification that all primers and coatings meet VOC emission limits specified in Section 01 6116. List manufacturer, brand, application, type (flat or non-flat), number of gallon, and the VOC emissions in grams/liter. Include MSDS and product data sheet indicating VOC limits for each product provided.
- E. Selection Samples: Manufacturer's color charts for flooring materials specified, indicating full range of colors and textures available.
- F. Verification Samples: Actual flooring material specified, not less than 6 inch square.

G. Closeout Submittals:

1. Manufacturer's recommendations for cleaning and maintaining flooring.
2. Warranty documents specified in WARRANTY Article of PART 1 of this section.

1.05 QUALITY ASSURANCE

- A. Installer Qualifications: An experienced installer certified in writing by the flooring manufacturer to be qualified for installation of specified flooring system.

1.06 DELIVERY, STORAGE, AND HANDLING

- A. Deliver materials to project site in unopened containers clearly labeled with manufacturer's name and identification of contents.
- B. Store materials in dry and clean location until needed for installation. During installation, handle in a manner that will prevent marring and soiling of finished surfaces.

1.07 FIELD CONDITIONS

- A. Maintain temperature in spaces to receive adhesively installed resilient flooring within range of 70-95 degrees F for not less than 48 hours before the beginning of installation and for not less than 48 hours after installation has been completed. Subsequently, do not allow temperature in installed spaces to drop below 50 degrees F or to go above 100 degrees F.

1.08 WARRANTY

- A. See Section 01 7000 - Contract Closeout, for additional warranty submittal requirements.
- B. Manufacturer's Warranty: Manufacturer's standard warranty against defects in products.

PART 2 PRODUCTS

2.01 PERFORMANCE REQUIREMENTS

- A. VOC Limits for adhesives, sealants, fillers, primers and coatings . Comply with limits specified in related section.
- B. Resilient Flooring VOC Emission Limits: Comply with CAL-GREEN 5.504.4.6; products must be listed on one of the following databases.
1. Collaborative for High Performance Schools (CHPS) 2009 CA Criteria and Low Emitting Materials List (Product Registry); www.chpsregistry.com/live/public.
 2. Resilient Floor Covering Institute (RFCI) FloorScore Program, database of certified products; www.scs-certified.com/products/index.php.
- C. ASTM D2047 Slip-Resistance: All Resilient Flooring Products shall meet or exceed Federal ADA recommendations of minimum Coefficient Of Friction of 0.6 for flat surfaces and 0.8 for sloped surfaces.
- D. Critical Radiant Flux (CRF): Minimum 0.45 watt per square centimeter, when tested in accordance with ASTM E 648 or NFPA 253.

2.02 PREFORMED ATHLETIC FLOORING

- A. Rubber Sheet Flooring: Recycled rubber tires and colored EPDM granules with urethane binder, lengths to avoid transverse seams.
1. Thickness: Minimum 1/4 inch (6 mm).Dual Layer with 1/8" minimum color wear layer.
 2. Sheet Width: Minimum 72 inches.
 3. Tensile Strength: Minimum 150 psi, per ASTM D412.
 4. Color: as selected from manufacturers standards (see basis of design product for relative minimum choices to be available)..

5. Manufacturers:
 - a. Basis of Design Manufacturer: Mondo; Sport Impact: www.mondoworldwide.com
 - b. Substitutions: See Section 01 6000 - Product Requirements.

2.03 ACCESSORIES

- A. Flooring Adhesive: Waterproof; types recommended by flooring manufacturer.
- B. Wall Base: Vented 4 inch rubber cove base as manufactured by Johnsonite.

PART 3 EXECUTION

3.01 EXAMINATION

- A. Examine substrates for conditions detrimental to installation of athletic flooring. Proceed with installation only after unsatisfactory conditions have been corrected.
 1. Beginning construction activities of this section indicates installer's acceptance of conditions.
- B. All inserts, penetrations and other construction items which affect the installation of the flooring to be in place.
- C. Cementitious Subfloors:
 1. Verify that substrates have been prepared and tested for moisture content and pH as specified in related sections.
 2. Verify preparation of substrate to specified flatness and levelness tolerances.
 3. Verify installation of Water Vapor Emission Control Coating (Moisture Mitigation System Coating) as specified in related section is complete and ready to receive flooring.

3.02 PREPARATION

- A. Remove coatings that are incompatible with flooring adhesives, using methods recommended by flooring manufacturer.
- B. Broom clean areas to receive athletic flooring immediately before beginning installation.

3.03 INSTALLATION

- A. Starting installation constitutes acceptance of sub-floor conditions.
- B. Comply with manufacturer's recommendations.
- C. Resilient Sheet Flooring:
 1. Unroll flooring and allow to relax before beginning installation.
 2. Mix adhesive thoroughly and apply to substrate with notched trowel. Roll flooring into fresh adhesive, overlapping end seams and double cutting, butting factory edges and compression fitting.
 3. Roll entire flooring surface with steel roller to assure adhesion to substrate and eliminate air bubbles.
 4. Immediately remove any adhesive from flooring surface, using chemical recommended by flooring manufacturer.
 5. Weld seams using techniques and equipment recommended by manufacturer.

3.04 CLEANING

- A. Clean flooring using methods recommended by manufacturer.

3.05 PROTECTION

- A. Protect finished athletic flooring from construction traffic to ensure that it is without damage upon Date of Substantial Completion.

Project Name
Enter District Name

Project No.1722.00

- B. Replace damaged flooring that cannot be repaired to appearance and function acceptable to Architect.

END OF SECTION

SECTION 09 6700
FLUID-APPLIED FLOORING

PART 1 GENERAL

1.01 SECTION INCLUDES

- A. Fluid-applied flooring and base.
 - 1. Medium Duty.
- B. Divider strips and accessories.
- C. Stone thresholds.

1.02 RELATED REQUIREMENTS

- A. Section 01 6116 - Volatile Organic Compound (VOC) Content Restrictions.
- B. Section 03 3000 - Cast In Place Concrete
- C. Pertinent sections specifying Concrete Floor Preparation and Concrete Floor Moisture Content.

1.03 REFERENCE STANDARDS

- A. ASTM C 307 - Standard Test Method for Tensile Strength of Chemical Resistant Mortar, Grouts, and Monolithic Surfacing.
- B. ASTM C 413 - Standard Test Method for Absorption of Chemical-Resistant Mortars, Grouts, Monolithic Surfacing, and Polymer Concretes.
- C. ASTM C579 - Standard Test Method for Compressive Strength of Chemical Resistant Mortar, Grouts, Monolithic Surfacing and Polymer Concretes.
- D. ASTM D638 - Standard Test Method for Tensile Properties of Plastics.
- E. ASTM D905 - Standard Test Method for Strength Properties of Adhesive Bonds in Shear by Compression Loading.
- F. ASTM D2047 - Standard Test Method for Static Coefficient of Friction of Polish-Coated Flooring Surfaces as Measured by the James Machine, 2004.
- G. ASTM D2794 - Standard Test Method for Resistance of Organic Coatings to the Effects of Rapid Deformation (Impact), 2010.
- H. ASTM E648 - Standard Test Method for Critical Radiant Flux of Floor-Covering Systems Using a Radiant Heat Energy Source.
- I. MIL-PRF-24613A, Performance Specification: Deck Covering Materials, Interior, Cosmetic Polymeric (03 Nov 2007).

1.04 SUBMITTALS

- A. See Section 01 3300 - Submittals, for submittal procedures.
- B. Product Data: Provide data on specified products, describing physical and performance characteristics; sizes, patterns and colors available . Demonstrate compliance with specified attributes.
- C. VOC Submittals:
 - 1. Product Data - VOC Limits: For adhesives sealants, fillers and primers, documentation including printed statement of VOC contents.
- D. Qualifications: For Manufacturer and Applicator. Demonstrate compliance with specified attributes.

- E. Samples: Submit two samples, 6" x 6" inch in size illustrating color and pattern for each floor material for each color specified.
- F. Manufacturer's Installation Instructions: Indicate special procedures.
- G. Maintenance Data: Include maintenance procedures, recommended maintenance materials, procedures for stain removal, repairing surface, and suggested schedule for cleaning.

1.05 QUALITY ASSURANCE

- A. Manufacturer Qualifications: Company specializing in manufacturing products specified in this section with minimum three years documented experience.
- B. Manufacturer's representative shall be available to advise applicator on proper surface preparation and application techniques.

1.06 MOCK-UP

- A. Following review of complete submittals, Provide complete mock-up, 6 feet long by 6 feet wide, illustrating finish color and texture.
- B. Locate where directed.
- C. Mock-up may remain as part of the Work.

1.07 DELIVERY, STORAGE, AND HANDLING

- A. Store resin materials in a dry, secure area.
- B. Store materials for three days prior to installation in area of installation to achieve temperature stability.

1.08 PROJECT CONDITIONS

- A. Sequence cabinet base and wall finish installation prior to fluid flooring to enable installation of integral coved flooring base in a single operation.
- B. Coordinate fluid flooring installation with size, location and installation of service utilities.

1.09 FIELD CONDITIONS

- A. Maintain minimum temperature in storage area of 55 degrees F.
- B. Maintain ambient temperature required by manufacturer 72 hours prior to, during, and 24 hours after installation of materials.

PART 2 PRODUCTS

2.01 MANUFACTURERS

- A. Fluid-Applied Flooring:
 - 1. BASF Construction Chemicals-Building Systems: www.buildingsystems.basf.com/#sle.
 - 2. Crossfield Products Corp; ____: www.crossfieldproducts.com/#sle.
 - 3. Sherwin-Williams Company: General Polymers Brand: www.generalpolymers.com.
 - 4. Tera-Lite, Inc.; www.tera-lite.com
 - 5. Stonhard, www.stonhard.com.
- B. Substitutions: See Section 01 6000 - Product Requirements.

2.02 MATERIALS

- A. VOC Limits for adhesives sealants, fillers, coatings and primers. Comply with limits specified in Section 01 6116.
- B. Provide Fluid-Applied Flooring with specified adhesion to concrete floors at up to 100% Relative Humidity as measured by ASTM D 2170, in situ probe testing.
- C. Fluid-Applied Troweled Flooring System, Medium Duty Type FF1: Epoxy, polymer modified, water-dispersed cementitious, three component, nominal 3/16 inch thickness.
 - 1. Products:
 - a. BASF Construction Chemicals-Building Systems: Selbatwede HD; www.buildingsystems.basf.com.
 - b. Crossfield Products Corp: Cheminert CFS: www.crossfieldproducts.com.
 - c. Sherwin-Williams Company: General Polymers Brand; TPM 115-U1: www.generalpolymers.com.
 - d. Stonhard; Stoneshield HRI; www.stonhard.com.
 - e. Tera-Lite; Tera-Gem III Decorative Quality (DQ) Troweled.
 - f. Substitutions: See Section 01 6000 - Product Requirements.
 - 2. Components:
 - a. Epoxy Primer: Manufacturer's standard penetrating two-component type.
 - b. Base Coat: 1/8 inch thick; selected color, three component mortar consisting of epoxy resin, curing agent and finely graded aggregates.
 - c. Undercoat (Receiving Coat): 100% solids epoxy formulation, three component, free-flowing.
 - d. Top Coat: Epoxy, single component; UV resistant, 1/16 inch thick; clear color.
 - e. Non-slip Surfacing: Quartz Aggregate, manufacturer's standard integral color type, suitable for broadcast application, selected color blend. Install to produce Coefficient of Friction between 0.7 and 0.8
 - 3. Performance Criteria:
 - a. Tensile Strength: 1,700 psi, when tested in accordance with ASTM D 307.
 - b. Compressive Strength: 10,000 psi, when tested in accordance with ASTM C 579.
 - c. Water Absorption: <0.1 percent, when tested in accordance with ASTM C 413 for 24 hr.
 - d. Mildew Resistance: No growth.
 - e. Adhesion in Shear (Bond) Strength: 300 PSI or failure of concrete bond minimum, when tested in accordance with ASTM D4541.
 - f. Impact Resistance: 60 in/lb; no cracking, chipping or delamination, when tested in accordance with ASTM D2794 or MILPRF24613.
 - g. Flammability: Self-Extinguishing (Class I) per ASTM E648.
 - h. Color: Selected from full range of available colors. Minimum of 7 colors in product line.
 - i. VOC Content: 100 g/l or less.
 - j. Coefficient of Friction, Installed: 0.60 minimum, wet, measured in accordance with ASTM D2047.
- D. Topical Vapor Control Coating for Fluid Flooring: Cementitious, polymer-modified three component, nominal 1/16 - 1/8 inch thickness, compatible with fluid-applied flooring. Allow successful installation of fluid applied flooring over concrete of 100 % Relative Humidity as measured by ASTM D2170 in situ probe.
 - 1. Primer: Manufacturer's standard penetrating type.
 - 2. Base Coat: 1/8 inch thick; selected color, polymer-modified mortar consisting of liquid latex resin and finely graded aggregates.

2.03 ACCESSORIES

- A. Base caps: Type recommended by manufacturer for conditions required.
- B. Cant Strips: Molded of flooring resin material.
- C. Thresholds: Marble, white or gray, honed finish; 2 inches wide by full width of wall or frame opening; thickness to fit application; beveled one long edge with radiused corners on top side; without holes, cracks, or open seams.
 - 1. Applications:
 - a. At doorways where epoxy flooring terminates.
 - b. At open edges of epoxy floor tile where adjacent finish is a different height.
- D. Primer: Type recommended by manufacturer for substrate and body coats indicated.
- E. Patching and Fill Material: Resinous product of or approved by epoxy coating manufacturer and recommended by manufacturer for application indicated.
- F. Sealant: manufacturer's recommended type, suitable for conditions required.
- G. Cleaners: Heavy-duty industrial detergent, manufacturer's recommended type, suitable for conditions required.
- H. Primers and Adhesives: Waterproof; types recommended by flooring manufacturer.

PART 3 EXECUTION

3.01 EXAMINATION

- A. Cementitious Subfloors:
 - 1. Verify that substrates have been prepared and tested for moisture content and pH as specified in related sections.
 - 2. Verify preparation of substrate to specified flatness and levelness tolerances as specified in related sections.
 - 3. Verify substrate has been mechanically cleaned and surface profiled as specified in related sections.
- B. Verify that sub-floor surfaces are dust-free and free of substances that could impair bonding of materials to sub-floor surfaces.
- C. Verify that sub-floor surfaces are sloped to drain, free of ponding areas or conditions which would impair positive drainage when installation is complete. Flood-test with water to confirm free drainage.
- D. Verify that required floor-mounted utilities are in correct location.

3.02 PREPARATION

- A. Crack Repair: Repair concrete slab cracks as recommended, using materials recommended by the flooring manufacturer and included in their warranty. Quantity Allowance: One lineal foot of crack repair per square foot of floor installation.
- B. Apply, trowel, and float filler to achieve smooth, flat, hard surface with positive drainage configuration. Grind irregularities above the surface level. Prohibit traffic until filler is cured.
- C. Vacuum clean substrate.
- D. Apply primer to surfaces required by flooring manufacturer.
- E. Install topical vapor control coating for fluid flooring complete with primer and recommended accessories at all areas indicated to receive fluid-flooring.

3.03 INSTALLATION - STRIPS

- A. Accurately saw cut substrate to install divider strips.
- B. Install thresholds and strips straight and level to locations indicated.
- C. Install fillet strips at base of walls where flooring is to be extended up wall as base.
- D. Install terminating cap strip at top of base; install "H" or "T" channel configurations as required to suit specific conditions where wall panel finishes abut base; attach securely to wall substrate.

3.04 INSTALLATION - FLOORING

- A. Apply in accordance with manufacturer's instructions.
- B. Apply each coat to minimum thickness required by manufacturer, free from trowel marks, swirls, pooled glaze or imperfections. Completed mock-up shall serve as appearance and texture standard for completed work.
- C. Apply first coat of clear sealer and broadcast aggregate to refusal and allow to cure as required by manufacturer. Sweep off excess aggregate and apply second seal coat to obtain specified thickness and surface finish textures matching approved mockups.
- D. Finish to smooth level surface with positive drainage as indicated. No ponding or birdbaths, all surface water flows to drain.
- E. Fillet and cove at vertical surfaces.
- F. Install sealants at perimeter and transition conditions in accordance with manufacturer's standard details and installation recommendations.

3.05 FIELD QUALITY CONTROL

- A. Following manufacturer's recommended curing period, and prior to installation of further work, flood completed floor with water in presence of Owner's Inspector to verify positive drainage.
- B. Completed work shall exhibit positive drainage, free from ponding or "birdbaths", with uniform color and texture consistent with the granular character of the flooring material, free of pooled, "swirled", or glazed topcoat, with surface finish textures matching approved mockups.
- C. Immediately remove and replace work not conforming to these requirements.
- D. Adjust textures at no cost to Owner at locations where finish textures do not match approved mockups:
 - 1. Too Rough: Apply additional coats of glaze topcoat until texture is acceptable.
 - 2. Too Smooth: Apply additional broadcast of aggregate and lock-in with additional glaze top coat until texture is acceptable.

3.06 PROTECTION

- A. Prohibit traffic on floor finish for 48 hours after installation.
- B. Barricade area to protect flooring until fully cured.

3.07 SCHEDULE

- A. Epoxy Floor Coating - Medium Duty: Total Assembly thickness 3/16 inch (188 mil) minimum.
 - 1. Surface Preparation - Concrete: SSPC-SP13 / NACE No. 6 Surface Preparation of Concrete, minimum concrete surface profile (CSP) 4-6 per ICRI Technical Guideline 03741, as recommended by Fluid Flooring Manufacturer.
 - 2. Repair cracks.

3. Topical Vapor Control Coating: If floor substrate Relative Humidity is outside manufacturer's recommended range, apply Topical Vapor Control Coating to horizontal surfaces, over prime coats as recommended by Manufacturer.
4. Primer: Apply prime coats to surfaces if recommended by Manufacturer.
5. Mortar / Slurry Base Coat: 3/16 inch (188 mils) DFT.
6. Color Finish / Topcoat: Color as selected; 8.0 to 12.0 mils DFT.
7. Integral Color Aggregate Broadcast to Refusal.
8. Clear Topcoat, minimum two: 8.0 to 12.0 mils DFT, total.

END OF SECTION

SECTION 09 7723

WALL PANELS

PART 1 GENERAL

1.01 SECTION INCLUDES

- A. Fiberglass reinforced composite panels.
- B. Trim and installation accessories.

1.02 RELATED SECTIONS

- A. Sections specifying products serving as substrates for wall panels.
- B. Section 09 2116 - Gypsum Board Assemblies: Wood-Fiber tackable panels to receive fabric wall coverings.

1.03 REFERENCES

- A. ASTM C 177 - Standard Test Method for Steady-State Heat Flux Measurements and Thermal Transmission Properties by Means of the Guarded-Hot-Plate Apparatus.
- B. ASTM D 256 - Standard Test Methods for Determining the Pendulum Impact Resistance of Notched Specimens of Plastics.
- C. ASTM D 543 - Standard Practices for Evaluating the Resistance of Plastics to Chemical Reagents.
- D. ASTM D 570 - Standard Test Method for Water Absorption of Plastics.
- E. ASTM D 638 - Standard Test Method for Tensile Properties of Plastics.
- F. ASTM D 1929 - Standard Test Method for Determining Ignition Temperature of Plastics.
- G. ASTM D 2583 - Standard Test Method for Indentation Hardness of Rigid Plastics by Means of a Barcol Impressor.
- H. ASTM D 3841 - Standard Specification for Glass-Fiber-Reinforced Polyester Plastic Panels.
- I. ASTM E 84 - Standard Test Method for Surface Burning Characteristics of Building Materials.

1.04 SUBMITTALS

- A. See Section 01 3300 - Submittals, for submittal procedures.
- B. Product Data: Provide manufacturer's standard details and catalog data demonstrating compliance with referenced standards. Provide installation instructions.
- C. Samples:
 - 1. Submit 6 inch square samples of each surface and color required.
 - 2. Submit 6 inch long samples of each trim profile and trim color required.
- D. Test Reports: Indicate conformance to specified requirements and referenced standards.

1.05 DELIVERY, STORAGE, AND HANDLING

- A. Store products indoors and protect from moisture, construction traffic, and damage.
- B. Store panels flat on clean, dry surface. Do not stand on edge or stack on fresh concrete or other surfaces that emit moisture.
- C. Store panels for at least 24 hours at temperature and humidity conditions approximating the average environment of the finished room.

1.06 ENVIRONMENTAL REQUIREMENTS

- A. Do not install materials when projects conditions do not meet manufacturer requirements.

1.07 EXTRA MATERIALS

- A. See Section 01 6000 - Product Requirements, for additional provisions.
- B. Supply five percent of installed area of each material and color for Owner 's use in maintenance of project.

PART 2 PRODUCTS

2.01 FIBERGLASS REINFORCED COMPOSITE PANELS

- A. General: Fiberglass reinforced composite panels.
 - 1. Composite plastic panels of random chopped fiber glass roving, modified polyester copolymer, inorganic fillers, and pigments.
 - 2. Resistant to rot, corrosion, staining, denting, peeling, and splintering.
 - 3. USDA accepted.
 - 4. Comply with ASTM D 3841, Type CC2.
- B. Sequentia Structoglas FRP Wall and Ceiling Panels; "FRFRJ/FX".
 - 1. Surface burning classification: Class A.
 - a. Flame spread (ASTM E 84): 25 or less.
 - b. Smoke developed (ASTM E 84): 450 or less.
 - 2. Flexural Strength (ASTM D 790): 13,600 psi.
 - 3. Flexural Modulus (ASTM D 790): 250,000 psi.
 - 4. Tensile Strength (ASTM D 638): 7,100 psi.
 - 5. Tensile Modulus (ASTM D 638): 920,000 psi.
 - 6. Impact Strength, IZOD (ASTM D 256): 12 ft-lb/in notched.
 - 7. Coefficient of Linear Thermal Expansion (ASTM D 696): 0.000017 in/in/degree F.
 - 8. Barcol Hardness (ASTM D 2583): 40.
 - 9. Water Absorption (ASTM D 570): 0.32 percent in 24 hrs. @ 77 degrees F.
- C. Size:
 - 1. Wall panel width: 48 inches.
 - 2. Wall panel length: Provide full-length panels unless substrate dimensions exceed available fabricated size.
 - 3. Ceiling panel width: 23-3/4 inches.
 - 4. Ceiling panel length: 47-3/4 inches.
 - 5. Thickness:
 - a. Wall and Ceiling Panels: 0.09 inch.
 - 6. Dimensional Tolerances:
 - a. Width and length: +/- 1/8 inch.
 - b. Thickness: +/- 10 percent.
 - c. Squareness: Not more than 1/8 inch out of square.
- D. Finishes:
 - 1. Exposed Surface: embossed pebbled textured finish.
 - 2. Back Surface: Smooth. Imperfections that do not affect functional properties are not cause for rejection.
 - 3. Color: As selected from manufacturer's standard colors, uniform throughout.
- E. Manufacturers:
 - 1. Crane Composites; 23525 W Eames, Channahon, IL 60410; www.cranecomposites.com
 - 2. Marlite; 15120 Marquardt Ave., Santa Fe Springs, CA 90670; www.marlitefrp.com

3. Substitutions: See Section 01 6000 - Product Requirements.

2.02 TRIM ACCESSORIES

- A. Fiberglass Reinforced Composite Panels: Provide panel manufacturer's standard moldings in colors and thickness matching panels, to meet project conditions.
 1. Outside angle.
 2. Inside angle.
 3. Panel Division Bar.
- B. Fasteners: Non-staining, as recommended by manufacturer in writing.
 1. Match panel colors at fiberglass reinforced composite panels.
 2. Concealed at laminate wall panels.
 3. Length to suit project conditions.
- C. Adhesive: Structural construction adhesive as recommended by manufacturer, meeting or exceeding specified fire code criteria.
- D. Sealant: Color matched silicone sealant as recommended by manufacturer.

PART 3 EXECUTION

3.01 EXAMINATION

- A. Examine substrates that will receive panels to ensure that surfaces are smooth, dry, true, and free of dirt, dust, oil, or grease.
- B. Remove high spots. Fill low spots.
- C. Apply leveling coat of plaster to concrete block walls, if required to bring surface to a true plane.
- D. Verify that substrate construction is completed and approved.
- E. Correct deficiencies in substrate before installing panels.
- F. All panels shall be allowed to equalize to the moisture and temperature in the room environment prior to installation, and in accordance with manufacturer's limitations.
- G. Panel edges must be refinished to manufacturer's instructions after field cutting, before installation. Field refinishing shall be provided as to match pre-finished edge.

3.02 INSTALLATION

- A. Install in accordance with manufacturer's printed installation instructions.
- B. Apply adhesive at temperature between 50 and 90 degrees F, unless otherwise recommended by manufacturer for specific project conditions.
 1. Spread adhesive 1/4-inch deep over entire back side of panel to achieve 100 percent coverage.
 2. Do not use beads of adhesive.
 3. Do not use mechanical fasteners or adhesive alone.
 4. Allow open time recommended by adhesive manufacturer before setting panels into position.
 5. Once in position, apply sufficient pressure to make full contact between panel and wall.
 6. Roll panel surface to ensure complete contact.
 7. If necessary, install bracing to maintain intimate contact until adhesive cures in accordance with manufacturer's instructions.
- C. Moldings:
 1. Trim division bar to accommodate ceiling and base moldings.
 2. Check plumb.

3. Apply sealant to leading edge of molding to receive next panel. Allow 1/8 inch clearance when installing panel.
 4. Remove excess sealant from panels and moldings.
- D. Sealants: Seal corner seams, ceiling and base junctures, around door frames and other openings, and between penetrating items and panel cut-outs.

3.03 ADJUST AND CLEAN

- A. Remove scraps and debris from the site and leave in a neat and clean condition.
- B. Protect installed Work from subsequent construction operations.

END OF SECTION

SECTION 09 9113
EXTERIOR PAINTING

PART 1 GENERAL

1.01 SECTION INCLUDES

- A. Surface preparation.
- B. Field application of paints, stains, and varnishes.
- C. Materials for backpriming woodwork.
- D. Scope: Finish exterior surfaces exposed to view, unless fully factory-finished and unless otherwise indicated, including the following:
 - 1. Exposed surfaces of steel lintels and ledge angles.
 - 2. Mechanical and Electrical:
 - a. On the roof and outdoors, paint equipment that is exposed to weather or to view, including factory-finished materials.

1.02 RELATED REQUIREMENTS

- A. Section 01 6116 - Volatile Organic Compound (VOC) Content Restrictions.
- B. Pertinent sections of Division 05 specifying shop-primed and galvanized metal items.
- C. Section 09 9123 - Interior Painting.
- D. Section 09 9623 - Anti-Graffiti Coatings.
- E. Pertinent sections specifying civil, mechanical and electrical work requiring painting.
- F. Pertinent Division 32 Section specifying Painted Pavement Markings.

1.03 DEFINITIONS

- A. Conform to ASTM D16 for interpretation of terms used in this section.

1.04 REFERENCE STANDARDS

- A. ASTM D16 - Standard Terminology for Paint, Related Coatings, Materials, and Applications.
- B. Manufacturer's recommendations and specifications, including installation instructions.
- C. MPI (APSM) - Master Painters Institute Architectural Painting Specification Manual.
- D. SSPC-SP 1 - Solvent Cleaning.
- E. SSPC-SP 2 - Hand Tool Cleaning.
- F. SSPC-SP 6 - Commercial Blast Cleaning.
- G. SSPC-SP 13 - Surface Preparation of Concrete; (Reaffirmed 2015).

1.05 SUBMITTALS

- A. See Section 01 3300 - Submittals, for submittal procedures.
- B. Product Data: Provide complete list of products to be used, with the following information for each:
 - 1. Manufacturer's name, product name and/or catalog number, and general product category (e.g. "alkyd enamel").
 - 2. MPI product number (e.g. MPI #47).

3. Cross-reference to specified paint system(s) product is to be used in; include description of each system.
 4. Manufacturer's installation instructions.
 5. If proposal of substitutions is allowed under submittal procedures, explanation of substitutions proposed.
 6. Resin Type.
 7. Total VOC Content in grams per liter.
 8. Solids Content By Volume SCBV (not solids by weight). All products shall be minimum 35% SCBV.
 9. Composition-By-Weight. Demonstrate composition by percentage related to total weight of all components.
 10. Film Thickness Per Coat, Wet and Dry.
 11. Prime Pigment: Demonstrate prime pigment by percentage related to total volume of all components.
- C. Samples: Submit three paper "draw down" samples, 8-1/2 by 11 inches in size, illustrating range of colors available for each finishing product specified.
1. Where sheen is specified, submit samples in only that sheen.
 2. Where sheen is not specified, discuss sheen options with Architect before preparing samples, to eliminate sheens definitely not required.
 3. Allow 30 days for approval process, after receipt of complete samples by Architect.
 4. Paint color submittals will not be considered until color submittals for major materials not to be painted, such as masonry, have been approved.
- D. Certification: By manufacturer that paints and finishes comply with VOC limits specified.
- E. Manufacturer's Instructions: Indicate special surface preparation procedures.
- F. Maintenance Data: Submit data including finish schedule showing where each product/color/finish was used, product technical data sheets, material safety data sheets (MSDS), care and cleaning instructions, touch-up procedures, repair of painted and finished surfaces, and color samples of each color and finish used.
- G. Maintenance Materials: Furnish the following for Owner's use in maintenance of project.
1. See Section 01 6000 - Product Requirements, for additional provisions.
 2. Extra Paint and Finish Materials: 1 gallon of each color; from the same product run, store where directed.
 3. Label each container with color in addition to the manufacturer's label.

1.06 QUALITY ASSURANCE

- A. Manufacturer Qualifications: Company specializing in manufacturing the products specified, with minimum ten (10) years documented experience.
- B. Applicator Qualifications: Company specializing in performing the type of work specified with minimum five (5) years experience and approved by manufacturer.

1.07 MOCK-UP

- A. See Section 01 4000 - Quality Requirements, for general requirements for mock-up.
- B. Provide panel, 8 feet long by 10 feet wide, illustrating paint color, texture, and finish.
- C. Provide door and frame assembly illustrating paint color, texture, and finish.
- D. Locate where directed by Architect.

- E. Final color selections and acceptance will be made only after review of mock-ups under lighting conditions approximating finish conditions.
- F. Mock-up may remain as part of the work.

1.08 DELIVERY, STORAGE, AND HANDLING

- A. Deliver products to site in sealed and labeled containers; inspect to verify acceptability.
- B. Container Label: Include manufacturer's name, type of paint, brand name, lot number, brand code, coverage, surface preparation, drying time, cleanup requirements, color designation, and instructions for mixing and reducing.
- C. Paint Materials: Store at minimum ambient temperature of 45 degrees F and a maximum of 90 degrees F, in ventilated area, and as required by manufacturer's instructions.

1.09 FIELD CONDITIONS

- A. Do not apply materials when surface and ambient temperatures are outside the temperature ranges required by the paint product manufacturer.
- B. Follow manufacturer's recommended procedures for producing best results, including testing of substrates, moisture in substrates, and humidity and temperature limitations.
- C. Do not apply exterior paint and finishes during rain, high wind or snow, or when relative humidity is outside the humidity ranges required by the paint product manufacturer.
 - 1. Do not paint exterior materials when inclement weather is expected within the full drying time specified by the manufacturer.
 - 2. Painting may be continued during inclement weather if areas and surfaces to be painted are enclosed and heated and dry within temperature and humidity limits specified by paint manufacturer during application and drying periods.
- D. Schedule work to avoid painting surfaces, when surfaces are exposed to direct sunlight.
- E. Provide lighting level of 80 ft candles measured mid-height at substrate surface.

PART 2 PRODUCTS

2.01 DESIGN REQUIREMENTS

- A. Design Intent: Paint all Work which is normally painted in a building of this type and quality, whether or not the item or surface is specifically identified within the Contract Documents.
 - 1. The number of coats specified is the minimum to be applied. Provide paint finishes of even, uniform color, free from cloudy or mottled surfaces. Provide one additional coat if necessary where "deep colors" are selected.
 - 2. Non-scheduled items: Provide manufacturer's approved and recommended system as set forth in Manufacturer's "Specifications Architectural Finishes".

2.02 MANUFACTURERS

- A. Manufacturer's proprietary names or catalog numbers are indicated for convenience in identifying products. Manufacturer's complete product catalog description and composition for indicated product names or numbers shall constitute requirements for each product specified. Products shall incorporate all attributes set forth in the manufacturer's catalog description for the specified item, except for such modifications thereto as may be indicated in the Contract Documents.
- B. Provide paints and finishes from the same manufacturer to the greatest extent possible.

1. In the event that a single manufacturer cannot provide specified products, minor exceptions will be permitted provided approval by Architect is obtained using the specified procedures for substitutions.
 2. Substitution of other products by the same manufacturer is preferred over substitution of products by a different manufacturer.
 3. Substitution of a different paint system using MPI-approved products by the same manufacturer will be considered.
- C. Substitutions: See Section 01 6000 - Product Requirements.
1. Provide product data documenting conformance to specified requirements and provide all specified information as listed above in SUBMITTALS article. Failure to include all information specified is grounds for rejection of substitution.
- D. Paints:
1. Base Manufacturer: Dunn Edwards Corporation, Los Angeles CA.
 2. Benjamin Moore & Co: www.benjaminmoore.com.
 3. Kelly-Moore; www.kellymoore.com.
 4. Sherwin-Williams Company: www.sherwin-williams.com/#sle.

2.03 PAINTS AND FINISHES - GENERAL

- A. Paints and Finishes: Ready mixed, unless required to be a field-catalyzed paint.
1. Provide paints and finishes of a soft paste consistency, capable of being readily and uniformly dispersed to a homogeneous coating, with good flow and brushing properties, and capable of drying or curing free of streaks or sags.
 2. Provide materials that are compatible with one another and the substrates indicated under conditions of service and application, as demonstrated by manufacturer based on testing and field experience.
 3. For opaque finishes, tint each coat including primer coat and intermediate coats, one-half shade lighter than succeeding coat, with final finish coat as base color.
 4. Supply each paint material in quantity required to complete entire project's work from a single production run.
 5. Do not reduce, thin, or dilute paint or finishes or add materials unless such procedure is specifically described in manufacturer's product instructions.
- B. Volatile Organic Compound (VOC) Content: Comply with Section 01 6116.
1. Provide products conforming with local, State and Federal government requirements limiting the amount of volatile organic compounds contained in the product, for its intended application. If specified product does not comply with current requirement, provide conforming product at no additional cost.
- C. Chemical Content: The following compounds are prohibited:
1. Intentionally added methylene chloride or perchloroethylene.
 2. Aromatic Compounds: In excess of 1.0 percent by weight of total aromatic compounds (hydrocarbon compounds containing one or more benzene rings).
 3. Acrolein, acrylonitrile, antimony, benzene, butyl benzyl phthalate, cadmium, di (2-ethylhexyl) phthalate, di-n-butyl phthalate, di-n-octyl phthalate, 1,2-dichlorobenzene, diethyl phthalate, dimethyl phthalate, ethylbenzene, ethylene glycol, formaldehyde, hexavalent chromium, isophorone, lead, mercury, methyl ethyl ketone, methyl isobutyl ketone, methylene chloride, naphthalene, toluene (methylbenzene), 1,1,1-trichloroethane, vinyl chloride.
- D. Flammability: Comply with applicable code for surface burning characteristics.
- E. Sheens: Provide the sheens specified; where sheen is not specified, sheen will be selected later by Architect from the manufacturer's full line.

1. Finish Sheen: The following designations are measured in percentage of reflectance when viewed at a 60 degree angle. Provide manufacturer's standard sheen most closely matching the characteristic of specified sheen.
 - a. Flat: 0-5%.
 - b. Velvet: 5-9%.
 - c. Eggshell: 10-15%.
 - d. Low Sheen: 20-25%.
 - e. Semi-Gloss: 40-50%
 - f. Gloss: 70-80%
 - g. High Gloss: >85%
- F. Colors: To be selected from manufacturer's full range of available colors.
 1. Selection to be made by Architect after award of contract.
 2. Allow for minimum of three colors for each system, unless otherwise indicated, without additional cost to Owner.
 3. Extend colors to surface edges; colors may change at any edge as directed by Architect.
 4. In finished areas, finish pipes, ducts, conduit, and equipment the same color as the wall/ceiling they are mounted on/under unless accent colors are denoted.
- G. Fabricate paints and stains in accordance with the Color Schedule which will include both standard colors and special, non-standard colors.
 1. If deep colors are not available in a specified product, propose substitute formula for approval
 2. Tint undercoats slightly to approximate finish coat color

2.04 PAINT SYSTEMS - EXTERIOR

- A. Paint WE-OP-3L - Wood, Opaque, Latex, 3 Coat:
 1. One coat of latex primer sealer.
 - a. Dunn-Edwards: E-Z PRIME Premium EZPR00.
 - b. Kelly-Moore: 255 ACRY-SHIELD.
 2. Gloss: Two coats of latex enamel
 - a. Dunn-Edwards: SPARTASHIELD SSSL60.
 - b. Kelly-Moore: Devoe Devcryl 1449.
 3. Semi-gloss: Two coats of latex enamel.
 - a. Dunn-Edwards: SPARTASHIELD SSSL50.
 - b. Kelly-Moore: 1250 ACRY-SHIELD.
- B. Paint CE-OP-3L - Masonry/Concrete, Opaque, Latex, 3 Coat:
 1. One coat of block filler:
 - a. Dunn-Edwards: Smooth BLOCFIL Premium SBPR00.
 - b. Kelly-Moore: 521 FILL & PRIME.
 2. Semi-gloss: Two coats of latex enamel.
 - a. Dunn-Edwards: EVERSIELD EVSH50.
 - b. Kelly-Moore: 1250 ACRY-SHIELD.
 3. Flat: Two coats of latex enamel; .
 - a. Dunn-Edwards: EVERSIELD EVSH10.
 - b. Kelly-Moore: 1240 ACRY-SHIELD.
- C. Paint GE-OP-3L - Gypsum Board or Plaster, Opaque, Latex, 3 Coat:
 1. One coat of epoxy primer sealer; .
 - a. Dunn-Edwards: SUPER-LOC Premium A&B SLPRA00, SLPRB00.
 - b. Kelly-Moore: Devoe Tru-Glaze WB 4426
 2. Flat: Two coats of latex.

- a. Dunn-Edwards: EVERSIELD EVSH10.
- b. Kelly-Moore: 1240 ACRY-SHIELD.
3. Eggshell: Two coats of latex enamel;
 - a. Dunn-Edwards: SPARTASHIELD SSSL30.
 - b. Kelly-Moore: 1245 ACRY-SHIELD.
- D. Paint ME-OP-3A - Ferrous Metals, Primed or Unprimed, Alkyd, 3 Coat:
 1. One coat of alkyd primer.
 - a. Dunn-Edwards: BLOC-RUST BRPR00-1-WH for light finish colors; BLOC-RUST BRPR00-1-RO for dark finish colors.
 - b. Kelly-Moore: Devoe Devprime 1405, Alkyd Rust-Preventative White Primer for light finish colors; Devoe Devprime 1405, Alkyd Rust-Preventative Red Primer for dark finish colors.
 2. Gloss: Two coats of alkyd enamel.
 - a. Dunn-Edwards: ARISTOSHIELD 60.
 - b. Kelly-Moore: 1700 KEL-GUARD.
 3. Semi-gloss: One coat of alkyd enamel.
 - a. Dunn-Edwards: ARISTOSHIELD 50.
 - b. Kelly-Moore, 2 coats: 1930 KM PROFESSIONAL Water - Oil Hybrid Int/Ext Semi-Gloss.
- E. Paint MgE-OP-3A - Galvanized Metals, Alkyd, 3 Coat:
 1. Pretreatment, reduce to minimum level for finish coat adhesion]. One coat .
 - a. Dunn-Edwards: Supreme Chemical Metal Clean and Etch ME01.
 - b. Kelly-Moore: Jasco Prep & Prime", Deveprep 88 Surface Cleaner & Degreaser.
 2. Prime Coat:
 - a. Dunn-Edwards: ULTRA-GRIP UGPR00 corrosion inhibitive primer.
 - b. Kelly-Moore: KM 5725 DTM Acrylic Primer/Finish.
 3. Gloss: One coat of alkyd enamel, exterior handrails and guardrails.
 - a. Dunn-Edwards: ARISTOSHIELD 60.
 - b. Kelly-Moore: KM 1980 Professional Waterborne Urethane Modified Alkyd High Gloss
 4. Semi-gloss: One coat of alkyd enamel, all other locations.
 - a. Dunn-Edwards: ARISTOSHIELD 50.
 - b. Kelly-Moore: 1930 KM PROFESSIONAL Water - Oil Hybrid Int/Ext Semi-Gloss.

2.05 PRIMERS

- A. Primers: As required or recommended by manufacturer of top coats; where the manufacturer offers options on primers for a particular substrate, use primer categorized as "best" by the manufacturer.

2.06 ACCESSORY MATERIALS

- A. Accessory Materials: Provide primers, sealers, cleaning agents, cleaning cloths, sanding materials, and clean-up materials as required for final completion of painted surfaces.
- B. Patching Material: Latex filler.
- C. Sanding materials: 120-180 grit, for architectural woodwork, finish carpentry, wood doors, or other surfaces requiring touch-up.
- D. Fastener Head Cover Material: Latex filler.

PART 3 EXECUTION

3.01 EXAMINATION

- A. Do not begin application of paints and finishes until substrates have been properly prepared.
- B. Verify that surfaces are ready to receive work as instructed by the product manufacturer.

- C. Examine surfaces scheduled to be finished prior to commencement of work. Report any condition that may potentially effect proper application.
- D. If substrate preparation is the responsibility of another installer, notify Architect of unsatisfactory preparation before proceeding.
- E. Test shop-applied primer for compatibility with subsequent cover materials.
- F. Measure moisture content of surfaces using an electronic moisture meter. Do not apply finishes unless moisture content of surfaces are below the manufacturer-recommended maximums.

3.02 PROTECTION OF ADJACENT WORK

- A. Protect surrounding elements from damage from painting procedures. Provide temporary facilities and barricades required. Additional requirements specified in Division 01.
- B. Carefully remove and store removable items located in areas to be painted, including fixtures, fittings, finish hardware, and accessories; reinstall upon completion.
- C. Separate areas to be protected from painting areas using means adequate to prevent damage.
- D. Cover existing landscaping with tarpaulins or similar covers.
- E. Mask immediately adjacent surfaces with material that will withstand cleaning and restoration procedures.
- F. Close off adjacent occupied areas with dust proof and weatherproof partitions.
- G. Protect roof membrane and flashings from damage with 1/2 inch plywood laid on roof surfaces over full extent of work area and traffic route.
- H. When using cleaning methods that involve water or other liquids, install drainage devices to prevent runoff over adjacent surfaces unless those surfaces are impervious to damage from runoff.

3.03 PREPARATION

- A. Clean surfaces thoroughly and correct defects prior to application.
- B. Prepare surfaces using the methods recommended by the manufacturer for achieving the best result for the substrate under the project conditions.
- C. Remove or repair existing paints or finishes that exhibit surface defects.
- D. Remove surface appurtenances, including electrical plates, hardware, light fixture trim, escutcheons, and fittings, prior to preparing surfaces for finishing.
- E. Surfaces: Correct defects and clean surfaces which affect work of this section. Feather-edge patches to make finished edges inconspicuous.
- F. Seal surfaces that might cause bleed through or staining of topcoat.
- G. Remove mildew from impervious surfaces by scrubbing with solution of tetra-sodium phosphate and bleach. Rinse with clean water and allow surface to dry.
- H. Provide barrier coats over incompatible primers, or remove and re-prime.
- I. Spot prime shop primed materials in field as required to assure that all surfaces are primed before finished coats are applied. Prime coats specified in this Section shall be provided in addition to shop prime coats on materials supplied for field finish.

- J. Verify compatibility of specified products with shop applied primer(s). In the event of incompatibility of products specified in the Section, recommend alternate compatible product for review.
- K. Provide full number of coats specified for each coating system indicated. Where recommended alternate compatible primers or undercoats require fewer coats than specified products, provide additional finish coat so that specified number of coats is not reduced.
- L. Concrete:
 - 1. Remove release agents, curing compounds, efflorescence, and chalk. Do not coat surfaces if moisture content or alkalinity of surfaces to be coated exceeds that permitted in manufacturer's written instructions.
 - 2. Prepare surface as recommended by top coat manufacturer and according to SSPC-SP 13.
- M. Exterior Plaster: Fill hairline cracks, small holes, and imperfections with exterior patching plaster. Make smooth and flush with adjacent surfaces. Wash and neutralize high alkali surfaces.
- N. Galvanized Surfaces:
 - 1. Remove surface contamination and oils and wash with solvent according to SSPC-SP 1.
 - 2. Prepare surface according to SSPC-SP 2.
- O. Ferrous Metal:
 - 1. Solvent clean according to SSPC-SP 1.
 - 2. Shop-Primed Surfaces: Sand and scrape to remove loose primer and rust. Feather edges to make touch-up patches inconspicuous. Clean surfaces with solvent. Prime bare steel surfaces. Re-prime entire shop-primed item.
 - 3. Remove rust, loose mill scale, and other foreign substances using using methods recommended in writing by paint manufacturer and blast cleaning according to SSPC-SP 6 "Commercial Blast Cleaning". Protect from corrosion until coated.
- P. Exterior Wood Surfaces to Receive Opaque Finish: Remove dust, grit, and foreign matter. Seal knots, pitch streaks, and sappy sections. Fill nail holes with tinted exterior calking compound after prime coat has been applied. Back prime concealed surfaces before installation.
- Q. Metal Doors to be Painted: Prime metal door top and bottom edge surfaces.

3.04 APPLICATION

- A. Remove unfinished louvers, grilles, covers, and access panels on mechanical and electrical components and paint separately.
- B. Exterior Wood to Receive Opaque Finish: If final painting must be delayed more than 2 weeks after installation of woodwork, apply primer within 2 weeks and final coating within 4 weeks.
- C. Apply products in accordance with manufacturer's written instructions and recommendations in "MPI Architectural Painting Specification Manual". In the event of conflict, manufacturer recommendations to prevail.
- D. Where adjacent sealant is to be painted, do not apply finish coats until sealant is applied.
- E. Do not apply finishes to surfaces that are not dry. Allow applied coats to dry before next coat is applied. Do not re-coat until;
 - 1. Paint has dried until firm to the touch.
 - 2. Paint does not deform or feel sticky under moderate thumb pressure.
 - 3. Application of another coat of paint will not cause lifting or loss of adhesion of the undercoat.
- F. Apply each coat to uniform appearance.

- G. Dark Colors and Deep Clear Colors: Regardless of number of coats specified, apply additional coats until complete hide is achieved.
- H. Sand wood and metal surfaces lightly between coats to achieve required finish.
- I. Vacuum clean surfaces of loose particles. Use tack cloth to remove dust and particles just prior to applying next coat.
- J. Make work uniform without sags, runs, skips or brush marks. Make all edges sharp including interior intersections and transitions between split finishes.
- K. Backprime all concealed surfaces of finish carpentry, architectural woodwork, wood doors and unclad wood windows.
- L. Reinstall electrical cover plates, hardware, light fixture trim, escutcheons, and fittings removed prior to finishing.

3.05 FINISHING MECHANICAL AND ELECTRICAL EQUIPMENT

- A. Paint shop-finished equipment (electrical panels, load centers, and similar elements) exposed to view. Factory coatings intended for finished exposure may remain in utility areas.
- B. Remove unfinished louvers, grilles, covers, and access panels on mechanical and electrical components and paint separately.
- C. Finish equipment, piping, conduit, and exposed duct work throughout in colors according to the color schedule.
- D. Reinstall electrical cover plates, hardware, light fixture trim, escutcheons, and fittings removed prior to finishing.

3.06 FIELD QUALITY CONTROL

- A. See Section 01 4000 - Quality Requirements, for general requirements for field inspection.

3.07 CLEANING

- A. Collect waste material that could constitute a fire hazard, place in closed metal containers, and remove daily from site.
- B. Upon completion of work, clean window glass and other paint-spattered surfaces.

3.08 PROTECTION

- A. Protect finishes until completion of project.
- B. Touch-up damaged finishes after Substantial Completion.
 - 1. Remove spatters, spots, runs, sags, blemishes and other defects without marring adjacent unpainted surfaces.
 - 2. Repaint defective surfaces.
- C. Provide "Wet Paint" signs as required to protect newly-painted finishes.
- D. Adjusting: Following owner's move-in and occupancy at a time acceptable to the Owner, touch-up and adjust blemishes and other defects incurred by move-in operations and the actions of the Owner and their separate contractors. Limit: Two workers for two full days labor, per building.

3.09 SCHEDULE - SURFACES TO BE FINISHED

- A. Do Not Paint or Finish the Following Items:

1. Items factory-finished unless otherwise indicated; materials and products having factory-applied primers are not considered factory finished.
 2. Items indicated to receive other finishes.
 3. Items indicated to remain unfinished.
 4. Fire rating labels, equipment serial number and capacity labels, and operating parts of equipment.
 5. Stainless steel, anodized aluminum, bronze, terne coated stainless steel, zinc, and lead items.
 6. Non-metallic roofing and flashing.
 7. Marble, granite, slate, and other natural stones.
 8. Ceramic and other types of tiles.
 9. Pre-finished wall, ceiling and floor materials or coverings, unless specifically scheduled for field painting.
 10. Floors, unless specifically indicated.
 11. Brick, glass unit masonry, architectural concrete, cast stone, integrally colored plaster and stucco unless specifically indicated.
 12. Glass.
 13. Concealed pipes, ducts, and conduits.
- B. General: Paint the surfaces described below under Schedule - Paint Systems. All surfaces exposed to weather, or visible to the eye, exterior and interior, unless specifically excluded by the Article titled "Do Not Paint or Finish the Following Items". If a coating system is not specified for a particular surface or substrate, provide a three-coat finish system recommended by the paint or coating manufacturer for that surface or substrate. Include all preparation necessary as appropriate for a similar substrate listed in the Article titled "PREPARATION", or preparation for that substrate as recommended by the paint or coating manufacturer.
- C. Mechanical and Electrical: Use paint systems defined for the materials to be finished.
1. Paint all conduit, insulated and exposed pipes, boxes, hangers, brackets, collars and supports, mechanical equipment, electrical equipment, and exposed ducts occurring in finished areas to match background surfaces, unless otherwise indicated.
 2. Paint all equipment, including that which is factory-finished, exposed to weather or to view on the roof and outdoors.
 3. Paint shop-primed items occurring in finished areas.
 4. Paint dampers exposed behind louvers, grilles, to match face panels.
- D. Paint behind moveable equipment and furniture.
- E. Finish top, bottom, and side edges of exterior doors the same as exposed faces.
- F. Paint access doors, fire hose and extinguisher cabinets, panelboards, conduits and exposed plumbing piping.
- G. Paint reveal moldings, expansion joints, and handrails.
- H. Paint tube column and miscellaneous connections.
- I. Provide split finishes for painted doors and interior windows where different connected room colors are selected.
- J. Paint continuous surfaces with the same paint system. Do not change systems at elevation breaks.
- K. Touch-up factory paint finishes where damaged.

3.10 SCHEDULE - PAINT SYSTEMS

- A. Concrete: Finish only surfaces exposed to view which are indicated to receive paint.
1. Exterior: Flat sheen.

- B. Plaster: Finish all surfaces exposed to view, except plaster with acrylic-modified finish per Section 09 2513..
 - 1. Exterior Walls and surfaces, including soffits, (Stucco): GE-OP-3L
- C. Wood: Finish all surfaces exposed to view.
 - 1. Exterior trim, beams, soffits and frames: WE-OP-3L.
 - a. Semi-gloss sheen.
- D. New Wood Doors: Factory-finished
- E. Steel Doors and Frames: Finish all surfaces exposed to view and to weather, including door tops and bottoms. Select prime coats compatible with finish color selections.
 - 1. Semi-gloss sheen.
- F. Metal Fabrications: Finish all surfaces exposed to view and concealed, before installation.. Select prime coats compatible with finish color selections.
 - 1. Exterior - Handrails and Guardrails: Gloss sheen.
 - 2. Exterior - All Other Surfaces: Semi-gloss sheen.
- G. Galvanized Steel and Shop-Primed Metal Items: Exterior and Interior; Finish all surfaces exposed to view and to weather, including exposed portions of roof deck systems.
 - 1. Exterior - Handrails and Guardrails: Gloss sheen.
 - 2. Exterior - All Other Surfaces: Semi-gloss sheen.
- H. Miscellaneous metals, conduits, non-factory-finished access panels: As specified for either unprimed or shop primed metals, modified as required to make sheen match adjacent surfaces. Finish the following items:
 - 1. Exposed portions of metal roof deck assemblies.
 - 2. Exposed surfaces of lintels.
 - 3. Exposed surfaces of steel stairs, ladders, fences, gates and railings.
 - 4. Mechanical and electrical equipment.
- I. Exterior Pavement Markings: As specified in related Division 32 section.

3.11 SCHEDULE - COLORS

- A. Building and Structure Exteriors: Allow individual Schedule with separate color selections for each Building:
 - 1. Walls; Field color as selected.
 - 2. Ceilings/soffits; as selected.
 - 3. Wainscot; as selected, allow for deep tones.
 - 4. Accent walls; as selected, allow for deep tones.
 - 5. Paint access doors and panels same as walls/wainscots.
 - 6. Wood Trim; as selected, allow for deep tones.
 - 7. Accent members; as selected, allow for deep tones.
 - 8. Doors and Frames; as selected, allow for deep tones and split finishes exterior/interior.
 - 9. Guardrails, handrails; as selected.
 - 10. Fences, gates; as selected.
 - 11. Rainwater leaders; as selected to match walls or gutters.
 - 12. Mechanical and electrical units and ductwork exposed to view; match wall/wainscot or as selected.
- B. Site Work:
 - 1. Vehicle Barriers, Bollards and Gates: Paint OSHA "Hi-Visibility" Yellow.
 - 2. Domestic, Fire and Irrigation Water Service Piping and Valves: Paint above-ground portions selected color.

3. Playground Equipment: Paint vertical posts of permanent basketball goals OSHA "Hi-Visibility" Yellow.

END OF SECTION

SECTION 09 9123
INTERIOR PAINTING

PART 1 GENERAL

1.01 SECTION INCLUDES

- A. Surface preparation.
- B. Field application of paints, stains, and varnishes.
- C. Materials for backpriming woodwork.
- D. Scope: Finish interior surfaces exposed to view, unless fully factory-finished and unless otherwise indicated.
 - 1. Both sides and edges of plywood backboards for electrical and telecom equipment before installing equipment.
 - 2. Prime surfaces to receive wall coverings.
 - 3. Mechanical and Electrical:
 - a. In finished areas, paint insulated and exposed pipes, conduit, boxes, insulated and exposed ducts, hangers, brackets, collars and supports, mechanical equipment, and electrical equipment, unless otherwise indicated.
 - b. In finished areas, paint shop-primed items.
 - c. Paint interior surfaces of air ducts that are visible through grilles and louvers with one coat of flat black paint to visible surfaces.
 - d. Paint dampers exposed behind louvers, grilles, and convactor and baseboard cabinets to match face panels.

1.02 RELATED REQUIREMENTS

- A. Section 01 6116 - Volatile Organic Compound (VOC) Content Restrictions.
- B. Pertinent sections of Division 05 specifying shop-primed and galvanized metal items.
- C. Section 09 7200 - Wall Coverings.

1.03 DEFINITIONS

- A. Conform to ASTM D16 for interpretation of terms used in this section.

1.04 REFERENCE STANDARDS

- A. 40 CFR 59, Subpart D - National Volatile Organic Compound Emission Standards for Architectural Coatings; U.S. Environmental Protection Agency.
- B. ASTM D16 - Standard Terminology for Paint, Related Coatings, Materials, and Applications.
- C. Manufacturer's recommendations and specifications, including installation instructions.
- D. MPI (APSM) - Master Painters Institute Architectural Painting Specification Manual.
- E. SSPC-SP 1 - Solvent Cleaning.
- F. SSPC-SP 2 - Hand Tool Cleaning.
- G. SSPC-SP 6 - Commercial Blast Cleaning.

1.05 SUBMITTALS

- A. See Section 01 3300 - Submittals, for submittal procedures.

- B. Product Data: Provide complete list of products to be used, with the following information for each:
1. Manufacturer's name, product name and/or catalog number, and general product category (e.g. "alkyd enamel").
 2. MPI product number (e.g. MPI #47).
 3. Cross-reference to specified paint system(s) product is to be used in; include description of each system.
 4. Manufacturer's installation instructions.
 5. If proposal of substitutions is allowed under submittal procedures, explanation of substitutions proposed.
 6. Resin Type.
 7. Total VOC Content in grams per liter.
 8. Solids Content By Volume SCBV (not solids by weight). All products shall be minimum 35% SCBV.
 9. Composition-By-Weight. Demonstrate composition by percentage related to total weight of all components.
 10. Film Thickness Per Coat, Wet and Dry.
 11. Prime Pigment: Demonstrate prime pigment by percentage related to total volume of all components.
- C. Samples: Submit three paper "draw down" samples, 8-1/2 by 11 inches in size, illustrating range of colors available for each finishing product specified.
1. Where sheen is specified, submit samples in only that sheen.
 2. Where sheen is not specified, discuss sheen options with Architect before preparing samples, to eliminate sheens definitely not required.
 3. Allow 30 days for approval process, after receipt of complete samples by Architect.
 4. Paint color submittals will not be considered until color submittals for major materials not to be painted, such as factory finished metals, wood cabinets, wood doors, and wall coverings and tile, have been approved.
- D. Certification: By manufacturer that paints and finishes comply with VOC limits specified.
- E. Manufacturer's Instructions: Indicate special surface preparation procedures.
- F. Maintenance Data: Submit data including finish schedule showing where each product/color/finish was used, product technical data sheets, material safety data sheets (MSDS), care and cleaning instructions, touch-up procedures, repair of painted and finished surfaces, and color samples of each color and finish used.
- G. Maintenance Materials: Furnish the following for Owner's use in maintenance of project.
1. See Section 01 6000 - Product Requirements, for additional provisions.
 2. Extra Paint and Finish Materials: 1 gallon of each color; from the same product run, store where directed.
 3. Label each container with color in addition to the manufacturer's label.

1.06 QUALITY ASSURANCE

- A. Manufacturer Qualifications: Company specializing in manufacturing the products specified, with minimum ten (10) years documented experience.
- B. Applicator Qualifications: Company specializing in performing the type of work specified with minimum five (5) years experience and approved by manufacturer.

1.07 MOCK-UP

- A. See Section 01 4000 - Quality Requirements, for general requirements for mock-up.

- B. Provide panel, 8 feet long by 10 feet wide, illustrating paint color, texture, and finish.
- C. Provide door and frame assembly illustrating paint color, texture, and finish.
- D. Locate where directed by Architect.
- E. Final color selections and acceptance will be made only after review of mock-ups under lighting conditions approximating finish conditions.
- F. Mock-up may remain as part of the work.

1.08 DELIVERY, STORAGE, AND HANDLING

- A. Deliver products to site in sealed and labeled containers; inspect to verify acceptability.
- B. Container Label: Include manufacturer's name, type of paint, brand name, lot number, brand code, coverage, surface preparation, drying time, cleanup requirements, color designation, and instructions for mixing and reducing.
- C. Paint Materials: Store at minimum ambient temperature of 45 degrees F and a maximum of 90 degrees F, in ventilated area, and as required by manufacturer's instructions.

1.09 FIELD CONDITIONS

- A. Do not apply materials when surface and ambient temperatures are outside the temperature ranges required by the paint product manufacturer.
- B. Follow manufacturer's recommended procedures for producing best results, including testing of substrates, moisture in substrates, and humidity and temperature limitations.
- C. Provide lighting level of 80 ft candles measured mid-height at substrate surface.

PART 2 PRODUCTS

2.01 MANUFACTURERS

- A. Paints:
 - 1. Benjamin Moore & Co: www.benjaminmoore.com.
 - 2. Dunn Edwards; www.dunnedwards.com.
 - 3. Kelly-Moore: www.kellymoore.com.
 - 4. Sherwin-Williams Company: www.sherwin-williams.com/#sle.

2.02 PAINTS AND FINISHES - GENERAL

- A. Paints and Finishes: Ready mixed, unless intended to be a field-catalyzed paint.
 - 1. Provide paints and finishes of a soft paste consistency, capable of being readily and uniformly dispersed to a homogeneous coating, with good flow and brushing properties, and capable of drying or curing free of streaks or sags.
 - 2. Supply each paint material in quantity required to complete entire project's work from a single production run.
 - 3. Do not reduce, thin, or dilute paint or finishes or add materials unless such procedure is specifically described in manufacturer's product instructions.
- B. Volatile Organic Compound (VOC) Content: Comply with Section 01 6116.
- C. Flammability: Comply with applicable code for surface burning characteristics.
- D. Sheens: Provide the sheens specified; where sheen is not specified, sheen will be selected later by Architect from the manufacturer's full line.
- E. Colors: To be selected from manufacturer's full range of available colors.

1. Selection to be made by Architect after award of contract.
2. Allow for minimum of three colors for each system, unless otherwise indicated, without additional cost to Owner.
3. Extend colors to surface edges; colors may change at any edge as directed by Architect.
4. In finished areas, finish pipes, ducts, conduit, and equipment the same color as the wall/ceiling they are mounted on/under.
5. In utility areas, finish equipment, piping, conduit, and exposed duct work in colors according to the color coding scheme indicated.

2.03 PAINT SYSTEMS - INTERIOR

- A. Paint WI-OP-3L - Wood, Opaque, Latex, 3 Coat:
1. One coat of latex primer sealer.
 - a. Cedar, redwood, architectural glue-laminated beams, provide number of coats necessary for stain resistance and uniform color:
 - 1) Dunn-Edwards: E-Z PRIME Premium EZPR00.
 - 2) Kelly-Moore: 255 ACRY-SHIELD.
 - b. All other interior wood:
 - 1) Dunn-Edwards: INTER-KOTE Premium IKPR00.
 - 2) Kelly-Moore: 973 Acry-Plex Zero VOC Interior Undercoat .
 2. Semi-gloss: Two coats of latex enamel; ; typical interior wood trim with opaque finish.
 - a. Dunn-Edwards: SUPREMA SPMA50.
 - b. Kelly-Moore: 1685 DURA-POXY.
 3. Eggshell: Two coats of latex enamel, typical exposed interior beams above 8'-0".
 - a. Dunn-Edwards: "SUPREMA SPMA30 ".
 - b. Kelly-Moore: "KM 1010 Premium Professional Zero VOC Eggshell Enamel".
- B. Paint MI-OP-3A - Ferrous Metals, Primed or Unprimed, Alkyd, 3 or 4 Coat (As specified and as required to achieve specified appearance):
1. One coat of alkyd primer:
 - a. Dunn Edwards: BLOC-RUST Premium BRPR00-1-WH.
 - b. Kelly-Moore: Devoe Devprime 1405 Alkyd Metal Primer.
 2. Gloss (Handrails and Guardrails): Alkyd enamel;
 - a. Dunn Edwards: One coat, ARISTOSHIELD 60.
 - b. Kelly-Moore: 2 coats, 1980 KM Professional Waterborne Urethane Modified Alkyd High Gloss.
 3. Semi-gloss (All other surfaces): Alkyd enamel; ,
 - a. Dunn Edwards: One coat, ARISTOSHIELD 50.
 - b. Kelly-Moore: 2 coats, 1930 KM Professional Water-Oil Hybrid Int/Ext Semi-Gloss Enamel.
 4. Low Sheen (For use in matching sheen of metal elements in wall surfaces): Latex enamel; .
 - a. Dunn Edwards: One coat, SPARTAZERO SZRO.
 - b. Kelly-Moore: 2 coats 1930 KM Professional Water - Oil Hybrid Int/Ext Semi-Gloss.
- C. Paint MI-OP-3L - Ferrous Metals, Primed or Unprimed, Latex, 3 Coat: Surfaces 8 feet or more above finish floor, trusses, metal roof deck, ductwork.
1. One coat of alkyd primer:
 - a. Dunn Edwards: BLOC-RUST Premium BRPR00-1-WH.
 - b. Kelly-Moore: Devoe Devprime 1405 Alkyd Metal Primer.
 2. Gloss (Exposed Spiral Ductwork): 2 coats of latex enamel;
 - a. Dunn Edwards: SPARTASHIELD SSSL.
 - b. Kelly-Moore: 1680 DURA-POXY + 100% Acrylic Gloss Enamel.
 3. Semi-gloss (Other Surfaces): 2 coats of latex enamel;

- a. Dunn Edwards: SPARTAZERO SZRO50.
 - b. Kelly-Moore: 1650 ACRY-PLEX Interior 100% Acrylic Semi-Gloss Enamel.
- D. Paint MI-IT-3A - Ferrous Metals, Primed or Unprimed, Intumescent Mastic Fireproofing, 3 Coat:
1. One coat of alkyd primer, type recommended by intumescent mastic fireproofing manufacturer.
 2. Intumescent Fireproofing, type specified in Section 07 8123.
 3. Gloss: One coat of enamel topcoating, type specified in Section 07 8123.
- E. Paint Mgl-OP-3A - Galvanized Metals, Alkyd, 3 Coat:
1. Pretreatment: reduce to minimum level for finish coat adhesion.
 - a. Dunn Edwards: Supreme Chemical Metal Clean and Etch ME01.
 - b. Kelly-Moore: Devprep 88 Surface Cleaner & Degreaser.
 2. One coat alkyd metal primer;
 - a. Dunn Edwards: ULTRA-GRIP Premium UGPR00.
 - b. Kelly-Moore: KM 5725 DTM Primer / Finish.
 3. Gloss (Handrails, Guardrails): Two coats of alkyd enamel;
 - a. Dunn Edwards: ARISTOSHIELD 60.
 - b. Kelly-Moore: 1980 KM Profession Water Urethane Modified Alkyd Gloss Enamel.
 4. Semi-gloss (All Other Locations): Two coats of alkyd enamel;
 - a. Dunn Edwards: ARISTOSHIELD 50.
 - b. Kelly-Moore: 1930 KM Professional Water -Oil Hybrid Int/Ext Semi-Gloss.
- F. Paint Mgl-OP-3L - Galvanized Metals, Latex, 3 Coats: Surfaces 8 feet or more above finished floor, metal roof deck, ductwork, etc.
1. Pretreatment: Solvent wash to remove oily residue, ensure finish coat adhesion.
 2. One coat galvanize primer:
 - a. Dunn Edwards: ULTRA-GRIP Premium UGPR00.
 - b. Kelly-Moore: KM 5725 DTM Primer / Finish.
 3. Gloss (Exterior of Exposed Mechanical Ductwork): Two coats of latex enamel;
 - a. Dunn Edwards: SPARTASHIELD SSSL60.
 - b. Kelly-Moore: 1680 DURA-POXY + 100% Acrylic Gloss Enamel.
 4. Semi-gloss (All Other Surfaces): Two coats of latex enamel;
 - a. Dunn Edwards: SPARTAZERO SZRO50.
 - b. Kelly-Moore: 1650 ACRY-PLEX Interior 100% Acrylic Semi-Gloss Enamel.
 5. Flat (Black color at visible interiors of mechanical ductwork): Two coats of latex enamel;
 - a. Dunn Edwards: SPARTAZERO SZRO10.
 - b. Kelly-Moore: 1240-407 ACRY-SHIELD 100% Acrylic Exterior Flat Finish, Color: Carbon.
- G. Paint GI-OP-3A-L Gypsum Board/Plaster, Acrylic, Low-VOC, 3 Coat:
1. One coat of low odor/low-VOC vinyl acrylic primer sealer: pigmented.
 - a. Dunn Edwards: ENSO ENSO00.
 - b. Kelly-Moore: 971 Acry-Plex Interior PVA Primer/Sealer Zero VOC".
 2. Semi-gloss: Two coats of low odor / low-VOC acrylic .
 - a. Dunn Edwards: ENSO ENSO50.
 - b. Kelly-Moore: 1520 ENVIRO-COAT Zero VOC, Interior 100% Acrylic Semi-Gloss Enamel.
 3. Eggshell: Two coats of low odor/low-VOC acrylic enamel
 - a. Dunn Edwards: ENSO ENSO30.
 - b. Kelly-Moore: KM 1010 Premium Professional Zero VOC Eggshell Enamel.
 4. Flat: Two coats of low odor/low-VOC Acrylic Wall Paint.
 - a. Dunn Edwards: ENSO ENSO10.
 - b. Kelly-Moore: KM 1005 Premium Professional Zero VOC, Interior Flat Wall Paint.

- H. Paint GI-P-1A - Gypsum Board/Plaster, Alkyd Primer, 1 Coat: Preparation for application of Wall Covering.
 - 1. One coat of primer sealer.
 - a. Dunn Edwards: ZINSSER Shieldz Universal Wallcovering Primer.
 - b. Kelly-Moore: 265 Water-Oil Hybrid Int/Ext Primer Undercoat.

2.04 PRIMERS

- A. Primers: As required or recommended by manufacturer of top coats; where the manufacturer offers options on primers for a particular substrate, use primer categorized as "best" by the manufacturer.

2.05 ACCESSORY MATERIALS

- A. Accessory Materials: Provide primers, sealers, cleaning agents, cleaning cloths, sanding materials, and clean-up materials as required for final completion of painted surfaces.
- B. Sanding materials: 120-180 grit, for architectural woodwork, finish carpentry, wood doors, or other surfaces requiring touch-up.
- C. Patching Material: Latex filler.
- D. Fastener Head Cover Material: Latex filler.

PART 3 EXECUTION

3.01 EXAMINATION

- A. Do not begin application of paints and finishes until substrates have been properly prepared.
- B. Verify that surfaces are ready to receive work as instructed by the product manufacturer.
- C. Examine surfaces scheduled to be finished prior to commencement of work. Report any condition that may potentially effect proper application.
- D. If substrate preparation is the responsibility of another installer, notify Architect of unsatisfactory preparation before proceeding.
- E. Test shop-applied primer for compatibility with subsequent cover materials.
- F. Measure moisture content of surfaces using an electronic moisture meter. Do not apply finishes unless moisture content of surfaces are below the manufacturer-recommended maximums.

3.02 PROTECTION OF ADJACENT WORK

- A. Protect surrounding elements from damage from painting procedures. Provide temporary facilities and barricades required. Additional requirements specified in Division 01.
- B. Carefully remove and store removable items located in areas to be painted, including fixtures, fittings, finish hardware, and accessories; reinstall upon completion.
- C. Separate areas to be protected from painting areas using means adequate to prevent damage.
- D. Cover existing interior planters and landscaping with tarpaulins or similar covers.
- E. Mask immediately adjacent surfaces with material that will withstand cleaning and restoration procedures.

3.03 PREPARATION

- A. Clean surfaces thoroughly and correct defects prior to application.

- B. Prepare surfaces using the methods recommended by the manufacturer for achieving the best result for the substrate under the project conditions.
- C. Remove or repair existing paints or finishes that exhibit surface defects.
- D. Remove or mask surface appurtenances, including electrical plates, hardware, light fixture trim, escutcheons, and fittings, prior to preparing surfaces or finishing.
- E. Seal surfaces that might cause bleed through or staining of topcoat.
- F. Remove mildew from impervious surfaces by scrubbing with solution of tetra-sodium phosphate and bleach. Rinse with clean water and allow surface to dry.
- G. Gypsum Board: Fill minor defects with filler compound. Spot prime defects after repair.
- H. Galvanized Surfaces:
 - 1. Remove surface contamination and oils and wash with solvent according to SSPC-SP 1.
 - 2. Prepare surface according to SSPC-SP 2.
- I. Ferrous Metal:
 - 1. Solvent clean according to SSPC-SP 1.
 - 2. Shop-Primed Surfaces: Sand and scrape to remove loose primer and rust. Feather edges to make touch-up patches inconspicuous. Clean surfaces with solvent. Prime bare steel surfaces. Re-prime entire shop-primed item.
 - 3. Remove rust, loose mill scale, and other foreign substances using using methods recommended in writing by paint manufacturer and blast cleaning according to SSPC-SP 6 "Commercial Blast Cleaning". Protect from corrosion until coated.
- J. Wood Surfaces to Receive Opaque Finish: Wipe off dust and grit prior to priming. Seal knots, pitch streaks, and sappy sections with sealer. Fill nail holes and cracks after primer has dried; sand between coats. Back prime concealed surfaces before installation.
- K. Metal Doors to be Painted: Prime metal door top and bottom edge surfaces.

3.04 PREPARATION - EXISTING SURFACES

- A. General: As specified above and as follows below.
- B. Remove or repair existing coatings that exhibit surface defects. Feather-edge patches to make finished edges inconspicuous.
- C. Existing Gypsum Board Surfaces to be Painted: Remove dirt, loose texturing, scale, salt or alkali powder, and other foreign matter. Remove oil and grease with a solution of tri-sodium phosphate; rinse well and allow to dry. Surfaces to be clean, dry, free of dirt, dust, grease, oil, mildew, efflorescence and other contaminants affecting paint adhesion or performance. Completely remove all loose, peeling or checked paints by sanding, scraping or other methods. Fill all holes and defects with suitable patching or spackling material compatible with the substrate material, allow to completely dry and sand to approximate existing adjacent textures. Spot prime patched areas.
- D. Existing Metal Surfaces With Existing Coatings to be Recoated; sheet metal flashings and trim, hollow metal doors, frames, columns and similar items. Sand and scrape to remove existing finishes, loose primer and rust. Clean surfaces with solvent. Prime bare metal surfaces. Feather edges to make touch-up patches inconspicuous.
- E. Existing Wood to Receive Opaque Finish: Completely remove all loose, peeling chalking, flaking or peeling paint by pressure-washing, scraping, wire brushing, sanding or other appropriate methods which will not damage existing substrates or adjacent finishes. Dull glossy surfaces to provide roughened surface for proper adhesion. Remove all loose sealant and glazing compounds. Feather

back rough paint edges and weathered wood material by sanding. Spot prime all areas before and after application of new sealants, patching or glazing materials. Remove dust, grit, and foreign matter. Seal knots, pitch streaks, and sappy sections. Fill nail holes with tinted exterior sealant compound after prime coat has been applied. Remove mildew growth as recommended by paint manufacturer.

- F. Existing Metal Doors to be Painted Sand, patch, clean with solvent. Prime metal door top and bottom edge surfaces. Finish otherwise as for Existing Metal Surfaces With Existing Coatings to be Recoated.

3.05 APPLICATION

- A. Remove unfinished louvers, grilles, covers, and access panels on mechanical and electrical components and paint separately.
- B. Apply products in accordance with manufacturer's written instructions and recommendations in "MPI Architectural Painting Specification Manual".
- C. Do not apply finishes to surfaces that are not dry. Allow applied coats to dry before next coat is applied.
- D. Apply each coat to uniform appearance in thicknesses specified by manufacturer.
- E. Sand wood and metal surfaces lightly between coats to achieve required finish.
- F. Vacuum clean surfaces of loose particles. Use tack cloth to remove dust and particles just prior to applying next coat.
- G. Reinstall electrical cover plates, hardware, light fixture trim, escutcheons, and fittings removed prior to finishing.

3.06 FIELD QUALITY CONTROL

- A. See Section 01 4000 - Quality Requirements, for general requirements for field inspection.

3.07 CLEANING

- A. Collect waste material that could constitute a fire hazard, place in closed metal containers, and remove daily from site.

3.08 PROTECTION

3.09 SCHEDULE - SURFACES TO BE FINISHED

- A. Do Not Paint or Finish the Following Items:
 - 1. Items factory-finished unless otherwise indicated; materials and products having factory-applied primers are not considered factory finished.
 - 2. Items indicated to receive other finishes.
 - 3. Items indicated to remain unfinished.
 - 4. Fire rating labels, equipment serial number and capacity labels, and operating parts of equipment.
 - 5. Stainless steel, anodized aluminum, bronze, terne coated stainless steel, zinc, and lead items.
 - 6. Marble, granite, slate, and other natural stones.
 - 7. Ceramic and other types of tiles.
 - 8. Pre-finished wall, ceiling and floor materials or coverings, unless specifically scheduled for field painting.
 - 9. Floors, unless specifically indicated.
 - 10. Brick, glass unit masonry, architectural concrete, cast stone, integrally colored plaster and stucco unless specifically indicated.
 - 11. Glass.

12. Concealed pipes, ducts, and conduits.
- B. General: Paint the surfaces described below under Schedule - Paint Systems. All surfaces exposed to weather, or visible to the eye, exterior and interior, unless specifically excluded by the Article titled "Do Not Paint or Finish the Following Items". If a coating system is not specified for a particular surface or substrate, provide a three-coat finish system recommended by the paint or coating manufacturer for that surface or substrate. Include all preparation necessary as appropriate for a similar substrate listed in the Article titled "PREPARATION", or preparation for that substrate as recommended by the paint or coating manufacturer.
- C. Mechanical and Electrical: Use paint systems defined for the materials to be finished.
 1. Paint all conduit, insulated and exposed pipes, boxes, hangers, brackets, collars and supports, mechanical equipment, electrical equipment, and exposed ducts occurring in finished areas to match background surfaces, unless otherwise indicated.
 2. Paint all equipment, including that which is factory-finished, exposed to weather or to view on the roof and outdoors.
 3. Paint shop-primed items occurring in finished areas.
 4. Paint interior surfaces of air ducts that are visible through grilles and louvers with one coat of flat black paint to visible surfaces.
 5. Paint dampers exposed behind louvers, grilles, to match face panels.
- D. Paint behind moveable equipment and furniture.
- E. Finish top, bottom, and side edges of interior doors the same as exposed faces.
- F. Paint access doors, fire hose and extinguisher cabinets, panelboards, conduits and exposed plumbing piping.
- G. Paint all exposed and semi-exposed galvanized metal, projections through and on roofs.
- H. Paint reveal moldings, expansion joints, and handrails.
- I. Paint tube column and miscellaneous connections.
- J. Provide split finishes for painted doors and interior windows where different connected room colors are selected.
- K. Paint continuous surfaces with the same paint system. Do not change systems at elevation breaks.
- L. Touch-up factory paint finishes where damaged.
- M. Paint both sides and edges of plywood backboards for electrical and telephone equipment before installing equipment.

3.10 SCHEDULE - PAINT SYSTEMS

- A. Gypsum Board: Finish all surfaces exposed to view, GI-OP-3A..
 1. Interior Ceilings and Bulkheads: Flat sheen.
 2. Interior Walls: Semi-gloss Sheen at Toilet Rooms, Custodians, Storage Room, Food Service.
 3. Interior Walls: Eggshell at Classrooms, Corridors, Administrative Offices and Work Rooms.
- B. Wood: Finish all surfaces exposed to view.
 1. Interior Opaque Finish: WI-OP-3L
 - a. Trim and frames: Semi-gloss sheen.
 - b. Beams: Low Sheen.
- C. Steel Doors and Frames: Finish all surfaces exposed to view and to weather, including door tops and bottoms. Select prime coats compatible with finish color selections. MI-OP-3A.

1. Semi-gloss sheen.
- D. Metal Fabrications, Galvanized Steel and Shop-Primed Metal Items: Finish all surfaces exposed to view and concealed, before installation, including exposed portions of metal roof or floor deck assemblies.. Select prime coats compatible with finish color selections. MI-OP-3A for surfaces under 8 feet above floor. MI-OP-3L for surfaces over 8 feet above floor.
 1. Interior - Handrails and exposed spiral seamed ductwork: Gloss sheen.
 2. Interior - All Other Surfaces: Semi-gloss sheen.
- E. Exposed Interior Steel with Intumescent Mastic Fireproofing: Finish all surfaces MI-IT-3A, Gloss.
- F. Miscellaneous metals, conduits, non factory finished access panels: As specified for either unprimed or shop primed metals, modified as required to make sheen match adjacent surfaces.
 1. Finish the following items:
 - a. Exposed portions of metal roof and floor deck assemblies.
 - b. Exposed surfaces of lintels.
 - c. Exposed surfaces of steel stairs, ladders, fences, gates and railings.
 - d. Mechanical equipment.
 - e. Electrical equipment.
- G. Wall and Substrate Surfaces Under Wall Covering: GI-P-1A.

3.11 SCHEDULE - COLORS

- A. Interiors, allow individual schedule for each Building:
 1. Walls; Field color as selected.
 2. Ceilings/soffits; as selected, allow for deep tones.
 3. Wainscot; as selected, allow for deep tones.
 4. Accent walls; as selected, allow for deep tones.
 5. Paint access doors and panels same as walls and wainscots.
 6. Wood Trim; as selected, allow for deep tones.
 7. Accent members; as selected, allow for deep tones.
 8. Doors and Frames; as selected, allow for deep tones and split finishes exterior/interior.
 9. Doors and Frames for Utility or staff access only, as selected; match walls/wainscot.
 10. Guardrails, handrails; as selected.
 11. Exposed trusses or structural members; as selected, allow for deep tones.
 12. Exposed ductwork; as selected, allow for deep tones.
 13. Mechanical or other equipment exposed to view; as selected or match wall/wainscot as directed.

END OF SECTION

SECTION 09 9623
ANTI-GRAFFITI COATINGS

PART 1 GENERAL

1.01 SECTION INCLUDES

- A. Clear anti-graffiti coating for exterior surfaces.

1.02 RELATED SECTIONS

- A. Section 07 4643 - Fiber Cement Panels.
- B. Section 07 9200 - Joint Sealers.

1.03 SYSTEM DESCRIPTION

- A. Anti-Graffiti Coating System: Clear, deep penetrating, non-film forming, non-yellowing, heavy duty, chemical water and graffiti repellent solutions.
- B. All products VOC - compliant to air quality standards prevailing at the project site.

1.04 SUBMITTALS

- A. See Section 01 3300 - Submittals, for submittal procedures.
- B. Product Data: Manufacturer's current technical data sheets for materials, and schedule indicating:
 - 1. Recommended waterproof coating serving as base layer of system;
 - 2. Number of coats required for subsequent coating types.
- C. Manufacturer's Field Reports: Indicate installation procedures, coverage, quantities, progress, unacceptable conditions and methods of resolution.
- D. Maintenance Data: Provide manufacturer's recommended maintenance procedures, including instructions for graffiti removal, recommended procedures for re-application of intermediate coatings and periodic maintenance of coating.
- E. Warranty: Submit manufacturer warranty and ensure that forms have been completed in Owner 's name and registered with manufacturer.

1.05 QUALITY ASSURANCE

- A. Mock-Up or Test Panels: Before full-scale application, test products to be used on a mock-up or test panels.
 - 1. Review manufacturer's product data sheets to determine suitability of each product for each surface.
 - 2. Apply products using manufacturer-approved application methods, determining actual requirements for surface preparation, coverage rate, number of coats, and application procedures.
 - 3. After 48 hours, review effectiveness of protection, compatibility with substrates, and ability to achieve desired results.
 - 4. Obtain approval by Architect and Owner of workmanship, color, and texture before proceeding with work.
 - 5. Test Panels: Inconspicuous sections of actual construction.
 - a. Location and number as selected by Architect.
 - b. Size: 4 feet by 4 feet.
 - c. Repair unacceptable work to the satisfaction of the Architect and Owner.
- B. Pre-Installation Meetings:

1. Before Application: Installer and Manufacturer's Representative shall inspect surfaces to be treated, noting in writing to the Architect, deficiencies or flaws in the substrate construction which would affect the performance or appearance of the coating.
 2. Beginning of Application: Manufacturer's Representative shall assure utilization of proper equipment, verify material quantities, and supervise material application techniques.
- C. Installer shall comply with recommendations and instructions set forth by manufacturer as part of manufacturer's service in addition to complying with the terms of the warranty.
- D. Installer Qualifications: Minimum 5 years of experience regularly engaged and specializing in the application of specialty surface treatments to exterior wall substrates.
- E. Do not proceed with material application until all deficiencies noted in pre-application inspection report have been corrected.
- F. Notify manufacturer no less than 72 hours before starting application.

1.06 DELIVERY, STORAGE, AND HANDLING

- A. Deliver materials in original sealed containers, clearly marked with manufacturer's name, type of material, and batch number.
- B. Inspect the materials upon delivery to assure that specified products have been received.
- C. Store materials where temperatures are not less than 45 degree F..
- D. Use all means necessary to protect material before, during, and after installation, and to protect work of other trades.

1.07 ENVIRONMENTAL REQUIREMENTS

- A. All materials shall comply with current Federal and State environmental requirements.

1.08 WARRANTY

- A. Manufacturer's Material Warranty: Manufacturer's 10 year warranty.
- B. Installer Warranty: Warrant workmanship for a period of two years from the date of Substantial Completion.

PART 2 PRODUCTS

2.01 MANUFACTURERS

- A. Acceptable Manufacturer: Rainguard Products Company; 3334 E Coast Hwy, #201, Corona del Mar CA 92625. Tel: 949-675-2811; Fax: 949-675-3450; Website: www.rainguard.com, products are specified.
- B. Substitutions: See Section 01 6000 - Product Requirements.

2.02 MATERIALS

- A. Liquid Water Repellent: Type recommended by manufacturer to suit indicated substrates.
- B. Liquid Water Repellent: Rainguard Products Company "Micro-Seal" with "Micro-Lok."
- C. Anti-Graffiti Coating: "Vandl-Guard", a chemically resistant one part, water-based, cross-linked co-polymer emulsion that dries to a clear, colorless film.
- D. Sacrificial Topcoat: "Vandl-Top", a chemically resistant topcoating compatible with underlying coatings that will not increase flammability of the substrate or support the growth of mildew, bacteria

or fungus. Intended for removal with graffiti in event of defacement of substrate and requiring re-application.

2.03 ANTI-GRAFFITI COATING SYSTEM

- A. System requires use of water-repellent coating: Type specified in this Section.
- B. Anti-Graffiti Coating:
 - 1. Clear water repellent, recommended type, one coat only;
 - 2. Anti-Graffiti Coating: "Vandl-Guard"; number of coats recommended by manufacturer to suit indicated substrates.
 - 3. Sacrificial Topcoat: "Vandl-Top", number of coats recommended by manufacturer to suit indicated substrates.

PART 3 EXECUTION

3.01 EXAMINATION

- A. Verify that surfaces to be coated are in proper condition.
 - 1. New substrates: Cured 30 days before application.
 - 2. Cured substrates: Allowed to dry three to seven days following rainfall before application.
 - 3. Substrate moisture content: No higher than 15 percent as registered on an electronic moisture meter.
- B. Do not apply to surfaces below 45 degrees F or above 90 degrees F. Do not apply in the direct sun.
- C. Where freezing conditions have existed before application, allow adequate time for building to thaw.
- D. Do not begin until mock-up/test panels have been approved by Architect.

3.02 PREPARATION

- A. Remove dirt, dust, oil, grease, and other contaminants that would interfere with penetration or performance of products; where cleaners are required, use products recommended by manufacturer; rinse thoroughly and allow to dry completely.
- B. Surfaces shall be structurally sound, dry, clean and free of dust, dirt, grime, oils, scale, rust, silicones, curing compounds, alkali, acid residues, etc.
- C. Prevent overspray, wind drift, and splash onto surfaces not to be treated.
- D. Protect windows and work of other trades against damage by coating, whether to be coated or not.
- E. Protect plant life against damage from coatings.

3.03 APPLICATION

- A. Apply materials in strict accordance with manufacturer's recommendations and when substrate surface temperature is above 45 degrees F..
 - 1. Follow instructions in manufacturer's current technical data sheet for general information and coverage rates.
- B. Mix materials in strict accordance with manufacturer's instructions; do not dilute unless permitted by manufacturer.
- C. Spray apply water repellent using high-volume, low-pressure spray equipment. Pressure not to exceed 60 psi. Hudson or garden-type sprayer can be used for small applications.
- D. Clean all drips, runs, and overspray residue while still wet.

- E. Allow coating(s) to dry and become clear before applying subsequent coats. Achieve a uniform pinhole free, continuous film.
- F. During process of work, remove discarded coating materials, rubbish, cans, and rags at end of each workday.

3.04 FIELD QUALITY CONTROL

- A. Provide the services of the manufacturer's authorized field representative to verify that installed products comply with manufacturer's requirements and with the standard established by the Architect -approved mock-up/ test panels.

3.05 ADJUSTING, CLEANING AND PROTECTION

- A. At completion of work, remove protective coverings.
- B. If surfaces that should have been protected from damage by this work have been damaged, clean, repair or replace to the satisfaction of the Architect.
- C. Repair or replace damaged treated surfaces.
- D. Protect completed work from damage during construction.

3.06 SCHEDULE

- A. Locations to receive anti-graffiti coating: South wall of Concession Building (Bldg A) and Stadium Entry Wall and all exposed surfaces of concrete wall between east side of entry avenue into stadium and adjacent parking area.

END OF SECTION

SECTION 10 0610

EXTERIOR SIGNAGE

PART 1 - GENERAL

1.1 RELATED DOCUMENTS

- A. Drawings and general provisions of the Contract, including General and Supplementary Conditions and Division 1 Specification Sections, apply to this Section.

1.2 SUMMARY

- A. Work Included: Installation of exterior traffic signage and related work as shown on the drawings and/or specified herein.
- B. Related Sections include:
 - 1. Section 10 1400 "Signage" for interior signage and exterior building signage
- C. References:
 - 1. State of California Maintenance Manual, latest editions.
 - 2. State of California Traffic Manual, latest edition.
 - 3. Regulations, standards, and tests of the State of California Materials and Research Division.
 - 4. State of California Standard Plans and Specifications.
 - 5. Americans with Disabilities Act.
 - 6. California Building Code, 2016 Edition.

1.3 SUBMITTALS

- A. Product Data: Submit manufacturer's product data describing materials and signs.
- B. Shop Drawings: Shop drawings with letter style and general layout for each sign type, with sizes, edge and corner treatment, and mounting methods shown.
- C. Selection Samples: For each finish specified, two complete sets of color chips representing manufacturer's full range of available colors, patterns and finishes.
- D. Verification Samples: For each finish product specified, one full-size sign representing actual product, color, patterns, and finishes. Include method if raised symbols and copy.

1.4 DELIVERY, STORAGE, AND HANDLING

- A. Comply with manufacturer's recommendations for delivery, storage and handling.
- B. Materials shall be delivered to the location in unopened, labeled factory containers. Upon delivery, materials shall be inspected for damage. Deficient materials shall not be used.

1.5 PROJECT CONDITIONS

- A. Maintain environmental conditions (temperature, humidity, and ventilation) within limits recommended by manufacturer for optimum results. Do not install products under environmental conditions outside manufacturer's absolute limits.

1.6 PERFORMANCE REQUIREMENTS

- A. All work shall be done to the satisfaction of the Owner or Owner's representative.
- B. Manufacturer's certificates showing conformance with this specification shall be delivered to Owner with each shipment of materials and equipment delivered to the job site.

PART 2 - PRODUCTS

2.1 MANUFACTURERS

- A. Acceptable Manufacturers: As selected by the Architect.

2.2 MATERIALS

- A. Traffic control sign panels shall be of the type, size, shape, and pattern designated or called for on the plans and detail drawings. Sign faces shall be of reflectorized porcelain enamel unless otherwise specified on the plans or detail drawings.
- B. Posts for traffic control signs, unless designated to be mounted on traffic signal or electrolier standards, shall be two (2) inch I.D. steel pipe conforming to the requirements of Section 56-2.02A of the State Standard Specifications.
- C. Mounting hardware for traffic control signs shall conform to the applicable requirements and specifications contained in the State of California Department of Transportation "Standard Plans" publication, latest edition.
- D. Concrete bases for traffic control sign posts shall be Class "B" Portland cement concrete of the shape and dimensions shown or called for on the plans and detail drawings.
Replace Portland cement in concrete with at least 30% of flyash or slag.

PART 3 - EXECUTION

- 3.1 Traffic control signs shall be installed in conformance with the applicable requirements of the State of California Maintenance Manual.
- 3.2 After installation, damage to traffic sign faces shall be touched up as required to the satisfaction of the Engineer.

END OF SECTION 10 0610

SECTION 10 1101
VISUAL DISPLAY BOARDS

PART 1 GENERAL

1.01 SECTION INCLUDES

- A. Markerboards and Tackboards.
 - 1. Fixed Types.
 - 2. Accessories.

1.02 RELATED REQUIREMENTS

- A. Section 01 6116 - Volatile Organic Compound (VOC) Content Restrictions.
- B. Section 01 8113 - Sustainable Design Requirements.
- C. Section 06 1000 - Rough Carpentry: Blocking and supports.

1.03 REFERENCE STANDARDS

- A. ANSI A135.4 - American National Standard for Basic Hardboard.
- B. ANSI A208.1 - American National Standard for Particleboard.
- C. ASTM A424/A424M - Standard Specification for Steel, Sheet, for Porcelain Enameling.
- D. California Code of Regulations, Title 24, Part 2, California Building Code (CBC), International Building Code.
- E. California Code of Regulations, Title 24, Part 11, California Green Building Standards Code, "CAL-Green".
- F. GREENGUARD Environmental Institute: GREENGUARD Indoor Air Quality Certified.
- G. Porcelain Enamel Institute: PEI-1002 Manual and Performance Specifications for Porcelain Enamel Writing Surfaces.

1.04 SUBMITTALS

- A. See Section 01 3300 - Submittals, for submittal procedures.
- B. Product Data: Provide manufacturer's data on chalkboard, markerboard, tackboard, tackboard surface covering, trim, and accessories.
- C. CAL-GREEN Submittals:
 - 1. Product Data - VOC Limits: For adhesives, sealants, fillers, primers and coatings, documentation including printed statement of VOC contents, comply with limits specified in related section.
 - 2. Composite Wood Formaldehyde Limits: Provide certification that all products meet current CARB Airborne Toxic Control Measure (ATCM) for Composite Wood Formaldehyde Limits by Mandatory Compliance Dates as specified in related section.
- D. Shop Drawings: Indicate wall elevations, dimensions, joint locations, special anchor details.
- E. Samples: Submit color charts for selection of color and texture of chalkboard, markerboard, tackboard, tackboard surface covering, and trim.
- F. Test Reports: Show conformance to specified surface burning characteristics requirements.
- G. Manufacturer's printed installation instructions.
- H. Maintenance Data: Include data on regular cleaning, stain removal, and maintenance precautions.

1.05 QUALITY ASSURANCE

- A. Manufacturer Qualifications: Company specializing in manufacturing the products specified in this section with minimum three years documented experience.

1.06 FIELD CONDITIONS

- A. Field measure prior to preparation of shop drawings and fabrication, to ensure proper fit.
- B. Do not begin installation of visual display boards until environmental conditions approximate normal occupied conditions.

1.07 WARRANTY

- A. See Section 01 7800 - Closeout Submittals, for additional warranty requirements.
- B. Submit manufacturer's "Life of the Building" warranty, stating that under normal usage and maintenance, and when installed in accordance with manufacturer's instructions and recommendations, porcelain enamel steel chalkboards and markerboards are guaranteed for the life of the building.
 - 1. Warranty shall cover replacement of defective boards but not the cost of removal or reinstallation.

PART 2 PRODUCTS

2.01 PERFORMANCE REQUIREMENTS

- A. VOC Limits for adhesives, sealants, fillers, primers and coatings . Comply with limits specified in related section.
- B. Composite Wood products must meet current CARB Airborne Toxic Control Measure (ATCM) for Composite Wood Formaldehyde Limits by Mandatory Compliance Dates as specified in Section 01 6116.

2.02 MANUFACTURERS

- A. Visual Display Boards:
 - 1. AARCO Products, Inc.; web: www.aarcoproducts.com .
 - 2. Claridge Products and Equipment, Inc; ____: www.claridgeproducts.com/#sle.
 - 3. Platinum Visual Systems as distributed by ABC School Equipment. www.pvsusa.com
 - 4. Substitutions: See Section 01 6000 - Product Requirements.

2.03 VISUAL DISPLAY BOARDS

- A. Markerboards: Porcelain enamel on steel, laminated to core.
 - 1. Steel Face Sheet Thickness: 24 gage, 0.0239 inch .
 - 2. Core: Particleboard, manufacturer's standard thickness, laminated to face sheet.
 - 3. Backing: Aluminum foil, laminated to core.
 - 4. Size: As indicated on drawings. If no size is shown, provide 48 inches by 96 inches.
 - 5. Frame: Extruded aluminum, with concealed fasteners.
 - 6. Frame Finish: Anodized, natural.
 - 7. Accessories: Provide chalk tray, map rail, and flag holder. (Two flag holders per room).

2.04 FABRICATION

- A. Laminate facing sheet and backing sheet to core material under pressure, using manufacturer's recommended adhesive.
- B. Provide factory-assembled visual display boards, except where sizes demand partial field assembly.
 - 1. Free of cups and bows, facing sheet and core continuous with no joints for entire length of board.

- C. Assemble units in one piece without joints, wherever possible. Where required dimensions exceed maximum panel size available, provide 2 or more pieces of equal length, as indicated on approved shop drawings. Assemble to verify fit at factory, then disassemble for delivery and final assembly at project site.
- D. Miter corners to neat hairline closure.
- E. Combination Units and Units Made of More Than One Panel: Factory-assembled chalkboards, markerboards, and tackboards in a single frame, of materials specified above.
 - 1. Join panels of different construction with H-shaped extruded aluminum molding finished to match frame.
 - 2. Join panels of similar construction with butt joints, aligned and secured with steel spline concealed in edge of core.
 - 3. Configuration: As indicated on drawings.

2.05 MATERIALS

- A. Porcelain Enameled Steel Sheet: ASTM A424/A424M, Type I, Commercial Steel, with fired-on vitreous finish.
- B. Hardboard for Cores: ANSI A135.4, Class 1 - Tempered, S2S (smooth two sides).
- C. Particleboard: ANSI A208.1; wood chips, set with waterproof resin binder, sanded faces.
- D. Foil Backing: Aluminum foil sheet, 0.005 inch thick.
- E. Adhesives: Type used by manufacturer.

2.06 ACCESSORIES

- A. Map Rail: Extruded aluminum, manufacturer's standard profile, with cork insert and runners for accessories; 1 inch wide overall, full width of frame.
- B. Temporary Protective Cover: Sheet polyethylene, 8 mil thick.
- C. Cleaning Instruction Plate: Provide instructions for chalkboard cleaning on a metal plate fastened to perimeter frame near chalkrail.
- D. Chalk Tray: Aluminum, manufacturer's standard profile, one piece full length of chalkboard, open ends, concealed fasteners, same finish as frame.
- E. Mounting Brackets: Concealed.

PART 3 EXECUTION

3.01 EXAMINATION

- A. Verify that field measurements are as indicated.
- B. Verify that internal wall blocking is ready to receive work and positioning dimensions are as indicated on shop drawings.

3.02 INSTALLATION

- A. Install boards in accordance with manufacturer's instructions.
- B. Install all grounds, clips, backing materials, adhesives, brackets, anchors, trim, and accessories necessary for a complete installation.
- C. Secure units level and plumb. Align perimeter trim for visual continuity and in accordance with manufacturer's recommendations.

- D. Butt Joints: Install with tight hairline joints.
- E. Where sliding visual display boards are installed in custom cabinets, provide track stops as recommended by board manufacturer to prevent sliding boards from impacting cabinet frames and comply with Referenced Standards for cabinet work.

3.03 CLEANING

- A. Verify that all accessories are installed as required for each unit.
- B. Clean board surfaces in accordance with manufacturer's instructions.
- C. Cover with protective cover, taped to frame.
- D. Remove temporary protective cover at Date of Substantial Completion.
- E. Protect completed work from damage until acceptance. Replace damaged work.

END OF SECTION

SECTION 10 1400
SIGNAGE

PART 1 GENERAL

1.01 SECTION INCLUDES

- A. Room and door signs with raised tactile letters and braille.
- B. Interior directional and informational signs with raised tactile letters and braille.
- C. Plaque.
- D. Vinyl Graphics.

1.02 RELATED REQUIREMENTS

- A. Division 08: Pertinent sections specifying doors and glazing materials serving as the mounting surface for signage.
- B. Division 09: Pertinent sections specifying wall finishes and substrates serving as the mounting surface for signage.

1.03 REFERENCE STANDARDS

- A. 36 CFR 1191 - Americans with Disabilities Act (ADA) Accessibility Guidelines for Buildings and Facilities; Architectural Barriers Act (ABA) Accessibility Guidelines.
- B. ADA Standards - Americans with Disabilities Act (ADA) Standards for Accessible Design.
- C. ICC A117.1 - Accessible and Usable Buildings and Facilities.
- D. California Code of Regulations, Title 24, Part 2, California Building Code (CBC), International Building Code.
- E. Standards for jurisdiction where project is located.

1.04 SUBMITTALS

- A. See Section 01 3300 - Submittals for submittal procedures.
- B. Product Data: Manufacturer's printed product literature for each type of sign, indicating sign styles, font, foreground and background colors, locations, overall dimensions of each sign.
- C. Signage Schedule: Provide information sufficient to completely define each sign for fabrication, including room number, room name, other text to be applied, sign and letter sizes, fonts, and colors.
 - 1. When room numbers to appear on signs differ from those on drawings, include the drawing room number on schedule.
 - 2. When content of signs is indicated to be determined later, request such information from Owner through Architect at least 2 months prior to start of fabrication; upon request, submit preliminary schedule.
 - 3. Submit for approval by Owner through Architect prior to fabrication.
- D. Shop Drawings: Indicate sign styles, lettering font, foreground and background colors, locations, overall dimensions of each sign.
 - 1. Submit shop drawing at scaled size for each typical sign. Indicate: Proposed copy, letter height, spacing and location of lettering on the sign field, colors and materials of each element and lettering. Tabular listing of signage and copy alone is not acceptable.
 - 2. Submit tabular listing for each sign keyed to location indicated on drawings, including all text and adjacent space for Owner modification/confirmation of text.

3. Provide all drawings and detail documents necessary to complete the project.
 4. Where sizes for signs are impacted by dimensions of surfaces or locations on which they are to be installed, verify dimensions by field measurement. Indicate measurements and signage locations on shop drawings for approval prior to production.
 5. Indicate for monument sign: Member and material profiles, sizes, connection attachments, reinforcing, anchorage, size and type of fasteners, and accessories. Include erection drawings, elevations, and details
- E. Samples: Submit two samples of each type of sign, of size similar to that required for project, illustrating sign style, font, and method of attachment.
- F. Selection Samples: Where colors are not specified, submit two sets of color selection charts or chips.
- G. Manufacturer's Installation Instructions: Include installation templates and attachment devices.

1.05 QUALITY ASSURANCE

- A. Manufacturer Qualifications: Company specializing in manufacturing the products specified in this section with minimum Five years of documented experience.
- B. Painted Logo Graphic Artist Qualifications: For sign installer, submit list of five projects completed within the last five years, with contact names and telephone numbers documenting experience specified in Article titled QUALITY ASSURANCE.

1.06 DELIVERY, STORAGE, AND HANDLING

- A. Package signs as required to prevent damage before installation.
- B. Package room and door signs in sequential order of installation, labeled by floor or building.

PART 2 PRODUCTS

2.01 REGULATORY REQUIREMENTS

- A. Conform to applicable code for requirements for the physically handicapped.
1. C.C.R., Title 24, Part 2. California Building Code, Section 1011.3, 1115B and 1117B, requirements governing signage design, location and attributes.
 2. Braille Symbols: California Contracted Grade 2 Braille symbols shall be used per CBC 1117B.5.6. Provide only domed Contracted Grade 2 Braille symbols as follows: Dots shall be 1/10 inch on center in each cell, with 2/10 inch space between cells. Dots shall be raised minimum of 1/40 inch above background.
- B. It is the sole responsibility of the signage contractor to obtain all permits required for signage contained in this project. Signage contractor to obtain, provide, produce and process all documentation, and pay all fees required for the permitting process.

2.02 MANUFACTURERS

- A. Plaque Signs:
1. Advance Corporation / Braille-Tac Division; Product Braille-Tac Etched Magnesium (Chemsast): 8200 - 97th Street South, Cottage Grove, Minnesota 55016; Telephone 800-328-9451; www.advancecorp.com/brailletac
 2. Substitutions: See Section 01 6000 - Product Requirements.
- B. Dimensional Letter Signs:
1. Cosco Industries; Cast Aluminum: www.coscoarchitecturalsigns.com/#sle.
 2. Substitutions: See Section 01 6000 - Product Requirements.
- C. Vinyl Graphics:

1. 3M / Commercial Products Division; Product 3M Premium Grade Vinyl: 3M Center, Building 220-6W-06, Post Office Box 33220, St. Paul, Minnesota 55133-3220: Telephone 800-374-6772.
2. Substitutions: See Section 01 6000 - Product Requirements.

2.03 SIGNAGE APPLICATIONS

- A. Accessibility Compliance: Signs are required to comply with ADA Standards and ICC A117.1 and applicable building codes, unless otherwise indicated; in the event of conflicting requirements, comply with the most comprehensive and specific requirements.
- B. Room and Door Signs: Provide a sign for every doorway, whether it has a door or not, not including corridors, lobbies, and similar open areas.
1. Sign Type: Flat signs with engraved panel media as specified.
 2. Provide "tactile" signage, with letters raised minimum 1/32 inch and Grade II braille.
 3. Character Height: 1 inch.
 4. Sign Height: 2 inches, unless otherwise indicated.
 5. Service Rooms: Identify with room names and numbers to be determined later, not those indicated on drawings.
 6. Rest Rooms: Identify with pictograms, the names "MEN" and "WOMEN", room numbers to be determined later, and braille, provide separate Facility Identification Symbols on doors as shown on Drawings.
- C. Interior Directional and Informational Signs:
1. Sign Type: Same as room and door signs.
 2. Lift Signage: Pictograms and copy shown on Drawings.
 3. Room Occupancy Signage: All rooms with Occupant Load greater than 50. Verify actual numbers with Architect.
 4. Tactile Exit and Exit Route Signs: Raised letters and Braille as specified for Room and Door signs.
 5. Exit Stair and Exit Ramp Signs: Raised letters and Braille as specified for Room and Door signs.
 6. Assistive Listening Sign: Pictogram and copy shown on Drawings.
 7. Other sign types indicated on the Drawings.
 8. Wording of signs is scheduled on drawings.
- D. Dimensional Letter Signs: Wall-mounted.
1. Exterior: Refer to Exterior Elevation drawings.
- E. Painted School Logo
1. Exterior: Refer to Exterior Elevation drawings.
- F. Traffic and Regulatory Signs: Conform to requirements of local authority having jurisdiction and CalTrans Traffic Manual for the type of sign indicated.

2.04 PLAQUE SIGNS

- A. Plaque Signs: One piece magnesium metal construction with raised character copy and braille with thermal-set, polyurethane finish. Tactile legends and Braille shall comply with Americans with Disabilities Act (ADA), California Building Code (CBC) and requirements indicated for quantities, sizes, layouts, materials, finishes, color, etc. as specified in the Graphics Schedule and Drawings/Specifications.
1. Exterior durability rating: 3 years minimum.
 2. Painted Finish:
 - a. Weatherability: When tested in accordance with ASTM G 53, after 500 hours in a Weatherometer (equivalent to 3 years of exterior exposure) gloss retention of not less than 88.0 determined in accordance with ASTM D 523 as a 60 degree angle.

- b. Color Fade Resistance: Color shall not change more than 1.68 units determined in accordance with ASTM D 2244 and measured with a Hunter colormeter, Model D25.
 - c. Durability: Sign finish shall show no effect after requested use of cleaners such as Graffiti Remover #1120 manufactured by Fine Organics Corp., Lodi, NJ.
 3. Colors: Custom, as selected by Architect.
 4. Total Thickness: 0.153 inches.
 5. Sign Edges: Square.
- B. Raised Characters:
1. Comply with applicable provisions of ANSI/ICC A117.1, including Braille.
 2. Character Color: As selected by Architect..
 3. Character Font: As Indicated.
 4. Character Stroke Width: As required by referenced codes, 1/8 inch.
 5. Character Height: As indicated. If not shown, provide 1 inch.
 6. Character Edges: Square.
 7. Character Case: Upper case only.

2.05 VINYL GRAPHICS

- A. Adhesive Vinyl Graphics of ISA for installation on glass or similar substrates.
- B. Base Material: Premium Grade with an outdoor durability rating of five years.
 1. Color: Provide as shown on Drawings. If no colors are indicated, provide International Blue with white pictograms..

2.06 ACCESSORIES

- A. Concealed Screws: Stainless steel, galvanized steel, chrome plated, or other non-corroding metal.
- B. Exposed Screws: Stainless steel.
- C. Mounting Hardware: Vandal-proof screws, stainless steel, size recommended by manufacturer to suit applications and resist applied loads.
- D. Adhesive: 3M Corporation, "VHB", applied in 5 mil thickness covering entire back of sign plaque without void or bubble.
- E. Silicon Adhesive: Silglaze II #2801 GE Clear - Silicone Sealant / Adhesive.
- F. Accessories and materials required for complete installation as indicated.

PART 3 EXECUTION

3.01 COORDINATION

- A. For signs supported by or anchored to permanent construction such as building such as building fascias, advise installers about specific requirements for placement of anchorage devices and similar items to be used for attaching signs.

3.02 EXAMINATION

- A. Confirm visibility of site signage and graphics in indicated locations. Do not install signs in locations where they will not be visible or where they will obstruct visibility of other related building elements, such as exit signage or life safety equipment provided under other contracts or sections. Request direction from Architect in the event of conflict with signage and building elements.
- B. Verify that substrate surfaces are ready to receive work.

- C. Clean substrates to receive adhered vinyl graphics or tape adhesive using means recommended by adhesive manufacturer that will not damage substrates. Remove contamination and materials that might impede film adhesion.

3.03 INSTALLATION

- A. Install in accordance with manufacturer's instructions.
- B. Install signs after surfaces are finished, in locations indicated.
- C. Install neatly, with horizontal edges level.
- D. Locate signs and mount at heights indicated on drawings and in accordance with ADA Standards and ICC A117.1.
- E. Install signage and graphics plumb, level and proportionally spaced or kerned as required for uniform appearance; centered on, or aligned with related building elements, measured from established lines and levels, accurately fitted, free from distortion or defects.
- F. Fastening to In-Place Construction: Provide anchorage devices and fasteners where necessary for securing items to in-place construction; including threaded fasteners for concrete inserts, toggle bolts, through-bolts, lag bolts, wood screws, and other connectors as required.
- G. Install vinyl graphics on clean substrates in accordance with vinyl manufacturer instructions, flat, smooth, free of defects, bubbles dust, blemishes and air pockets.
- H. Plaque Mounting on Glazing: Install on glazing with double stick tape and silicone adhesive. Provide self-adhesive opaque plastic film, in matching or contrasting color as selected, to conceal reverse side of signs mounted on glazing. No exposed fasteners, adhesives or glazing tapes permitted. Film backer must be computer cut to match the shape of the plaque(s).
- I. Plaque Mounting at all other interior locations: Provide double stick tape and silicone.
- J. Plaque Mounting at all other exterior locations: Provide double stick tape and anchorage devices and fasteners as necessary for securing items to in-place construction; including threaded fasteners for concrete inserts, toggle bolts, through-bolts, lag bolts, wood screws, wedge anchors and other connectors as required.

3.04 ADJUSTING

- A. Correct all damaged work by cleaning, repairing or replacing, and repainting, as acceptable to Architect.
- B. Protect from damage until Substantial Completion; repair or replace damaged items.

END OF SECTION

SECTION 10 2113

REINFORCED COMPOSITE TOILET COMPARTMENTS

PART 1 GENERAL

1.01 SECTION INCLUDES

- A. Reinforced Composite toilet compartments.
- B. Urinal and Vestibule screens.

1.02 RELATED SECTIONS

- A. Pertinent sections of other divisions specifying backing and blocking for compartment support.
- B. Section 06 1000 - Rough Carpentry: Concealed wood framing and blocking for compartment support.
- C. Section 10 2800 - Toilet Accessories.

1.03 REFERENCES

- A. ADA STANDARDS - Americans with disabilities Act (ADA) Standards for Accessible Design; 2010.
- B. ANSI A117.1-1998 Specifications for Making Buildings and Facilities Accessible to and Usable by Physically Handicapped People.
- C. American Society for Testing and Materials Standards:
 - 1. ASTM A 666 - Standard Specification for Annealed or Cold-Worked Austenitic Stainless Steel Sheet, Strip, Plate, and Flat Bar; 2000.
 - 2. ASTM E84-01 Standard Test Method for Surface Burning Characteristics of Building Material.
 - 3. ASTM D2794-93(1999)e1 Standard Test Method for Resistance of Organic Coatings to the Effects of Rapid Deformation (Impact).
 - 4. ASTM D2197-98(2002) Standard Test Method for Adhesion of Organic Coatings by Scrape Adhesion.
 - 5. ASTM D6578-00 Standard Practice for Determination of Graffiti Resistance.
- D. Manufacturer's recommendations for installation.
- E. C.C.R., Title 24, Part 2. California Building Code, edition as noted on the drawings.
- F. US Green Building Council (USGBC) Leadership in Energy and Environmental Design (LEED) Program, latest Version.

1.04 PERFORMANCE REQUIREMENTS

- A. Conform to applicable codes and referenced standards for accessibility requirements.
- B. Graffiti Resistance: Partition material shall have the following graffiti removal characteristics when tested in accordance with ASTM D6578-00 Standard Practice for Determination of Graffiti Resistance in accordance with Section 9, "Graffiti Removal Procedure Using Manual Solvent Rubs":
 - 1. Cleanability: Five (5) required staining agents shall be cleaned off material.
- C. Scratch Resistance: Partition material shall have the following characteristics when tested in accordance with ASTM D2197-98(2002) Standard Test Method for Adhesion of Organic Coating by Scrape Adhesion, using Gardner Stock #PA-2197/ST pointed stylus attachment on scrape tester:
 - 1. Scratch Resistance: Maximum Load Value shall exceed 10 kilograms.
- D. Impact Resistance: Partition material shall have the following characteristics when tested in accordance with ASTM D2794-93(1999)e1 Standard Test Method for Resistance of Organic Coating to

the Effects of Rapid Deformation (Impact), using .625" hemispherical indenter with 2-lb impact weight:

1. Impact Resistance: Maximum Impact Force value shall exceed 30 inch-lbs.
- E. Fire Resistance: Partition material shall comply with the following requirements, when tested in accordance with ASTM E 84: Standard Test Method for Surface Burning Characteristics of Building Materials:
1. Smoke Developed Index: Not to exceed 450.
 2. Flame Spread Index: Not to exceed 75.
 3. Material Fire Ratings:
 - a. National Fire Protection Association (NFPA): Class B.
 - b. International Code Council (ICC): Class B.

1.05 SUBMITTALS

- A. See Section 01 3300 - Submittals, for submittal procedures.
- B. Shop Drawings: Indicate partition plan, elevation views, dimensions, details of wall supports, door swings, anchorage, accessory items and finishes. Provide location drawings for bolt hole locations in supporting members for attachment of compartments.
- C. Product Data: Provide data on panel construction, hardware, and accessories, demonstrate conformance with specified requirements.
- D. Samples:
 1. Selection Samples: Submit three samples of partition panels, 3 x 3 inch in size illustrating panel finish, color, and sheen.
 2. Verification Samples: Provide, upon request, additional samples of partition panels for use in preparing final color boards.
 3. Scale Model: Upon request, provide scale model of compartments, including stile, shoe, door, door hardware, divider panel, and mounting brackets. Provide sections showing stile anchoring and leveling devices, concealed threaded inserts, panel, stile, and edge construction. Scale models will be returned following review.
- E. Manufacturer's Installation Instructions: Indicate special procedures.
- F. Cleaning and maintenance information including how to obtain replacement parts.

1.06 DELIVERY, STORAGE AND HANDLING

- A. Deliver and store items in manufacturer's original unopened protective packaging, prevent physical damage or wetting.
- B. Prevent damage to finished surfaces during handling.

1.07 WARRANTY

- A. Provide ten-year limited warranty for panels, doors, and stiles against breakage, corrosion, delamination, and defects in factory workmanship.
- B. Provide one-year guarantee against defects in material and workmanship for stainless steel door hardware and mounting brackets.

1.08 COORDINATION

- A. Coordinate the work with placement of support framing and anchors in wall.

PART 2 PRODUCTS

2.01 MANUFACTURERS

- A. Reinforced Composite Toilet Compartments: "Sierra™ Series 1092.67 " as manufactured by Bobrick Washroom Equipment, Inc., www.bobrick.com, as represented by R. E. Edwards, 925-829-2942.
- B. Toilet partitions constructed of High Density Polyethylene (HDPE) or High Density Polypropylene will not be acceptable.
- C. Substitutions: Section 01 6000 - Product Requirements.
 - 1. Request For Substitution of proposed alternate systems must be made in writing as specified in Section 01 6000 and shall demonstrate that the proposed substitution meets or exceeds the specified characteristics.
 - 2. All performance requirements listed in Articles titled QUALITY ASSURANCE, DESIGN CRITERIA, PERFORMANCE REQUIREMENTS and WARRANTY must be met and documented with the Request For Substitution.
 - 3. Submit complete product and test data as specified under SUBMITTALS for each proposed substitution.
 - 4. Architect will accept or reject Request for Substitution in writing as specified in Section 01 6000. Accepted substitutions will be issued via Addendum.
 - 5. No substitutions will be accepted following the bid, except as otherwise specified in Section 01 6000.

2.02 MATERIALS

- A. Reinforced Composite Material: composed of dyes, organic fibrous material, and polycarbonate/ phenolic resins; non-ghosting, graffiti-resistant surface integrally bonded to core through a series of manufacturing steps requiring thermal and mechanical pressure. Edges of material shall be the same color as the surface., with solid integral color through the full depth of the panel.
- B. Stainless Steel: ASTM A 666, 18-8 Type 304 stainless steel with No. 4 finish.
- C. Aluminum: Satin finish, extruded anodized aluminum. Provide for specified items only.

2.03 COMPONENTS

- A. Toilet Compartments: Solid reinforced composite panels, doors, and pilasters, floor-mounted headrail-braced. Stiles, Panels, Doors, and Screens shall be all be manufactured from Solid Color Reinforced Composite material.
 - 1. Provide materials selected for surface flatness and smoothness. No exposed surfaces which show pitting, seam marks, roller marks, stains, discoloration, or other imperfections.
 - 2. Color: As selected by Architect from Manufacturer's standards.
- B. Panel and Bench Thickness: 1/2 inch.
- C. Door and Stile Dimensions:
 - 1. Thickness: 3/4 inch.
 - 2. Door Width: 24 inch.
 - 3. Door Width at accessible stall: 36 inch.
- D. Urinal Screens: Urinal screens are to be floorceilinganchored with post mounted to panel. Stile to be 3/4"thick material, with urinal panel made of 1/2" thick material attached to wall with two mounting brackets.

2.04 ACCESSORIES

- A. Hardware - General: Polished stainless steel at all locations, unless noted otherwise below:

- B. Vandal-Resistant Hinges:
 - 1. 16-gauge (1.6-mm) continuous piano hinge, self-closing type.
 - 2. At wheelchair accessible stalls, provide self-closing type, adjustable to closed position at outswinging application.
 - 3. Provide exterior emergency access feature.
- C. Door Stop Plates: 11-gauge (3-mm) stainless steel with attached rubber bumpers, two per door to resist door from being kicked in/out beyond stile.
- D. Vandal-Resistant Latch:
 - 1. Sliding door latch 14 gauge (2 mm) on nylon track.
 - 2. Operate with less than 5-lb force. Twisting latch operation will not be acceptable.
 - 3. Attach Latch track to door by machine screws into factory-installed threaded brass inserts.
 - 4. Threaded brass inserts: Factory installed for door hinge and latch connections.
 - 5. Latch keeper-to-stile connections: Through-bolted, stainless steel, pin-in-head Torx sex bolt fasteners.
- E. Door Strike and Keeper with rubber bumper; mounted on pilaster in alignment with door latch.
- F. Coat Hook: Stainless steel with rubber bumper; one per compartment, mounted on door. Maximum projection 1-1/8 inches, Bobrick B-233 Clothes Hook. Secure to door by through-bolted, theft-resistant, pin-in-head Torx stainless steel screws.
- G. Mounting Brackets:
 - 1. Stainless steel, mounted inside compartment.
 - 2. Provide double thickness 11 gauge brackets at wall mounted urinal screens.
- H. Panel-to-Stile connections.
 - 1. Mounting brackets: 18-gauge (1.2- mm) stainless steel, full height of panel.
 - 2. U-channels: Panel-to-stile connections.
 - 3. Angle brackets: Secure stiles to walls and panels to walls.
- I. Leveling Device: 7-gauge, 3/16" (5-mm) hot rolled steel bar; chromate-treated and zinc-plated; through-bolted to base of solid color reinforced composite stile.
 - 1. Provide adjustment for floor variations with screw jack through steel saddles integral with pilaster.
- J. Stile Shoe: One-piece, 4" (102-mm) high, 22-gauge (0.8-mm) stainless steel. Top shall have 90° return to stile. Shoe: one-piece of stainless steel and capable of being fastened (by clip) to stiles starting at wall line.
- K. Headrail (Overhead Braced Configurations): Aluminum (.125" / 3-mm thick) with anti-grip profile.
- L. Door Pull: Stainless steel "wire-type" or u-shaped type, outside of outswinging doors and one at each side of wheelchair accessible stall doors.
- M. Fasteners and Threaded Inserts:
 - 1. Theft-and-Vandal-resistant, pin-in-head Torx stainless steel machine screws with factory-installed, threaded brass inserts.
 - 2. Theft-and-Vandal-resistant, through-bolted pin-in-head Torx stainless steel sex bolt fasteners.
 - 3. Fasteners secured directly into the core are not acceptable.
 - 4. All fasteners and threaded brass inserts shall withstand a direct pull force exceeding 1,500 lbs per fastener or insert.

PART 3 EXECUTION

3.01 EXAMINATION

- A. Verify that field measurements are as indicated.
- B. Verify correct spacing of and between plumbing fixtures.
- C. Verify correct location of built-in framing, anchorage, and bracing.

3.02 INSTALLATION

- A. Install partitions secure, rigid, plumb, and level in accordance with manufacturer's instructions. Installation methods shall conform to manufacturer's recommendation for backing and proper support.
- B. Maintain 3/8 to 1/2 inch space between wall and panels and between wall and end pilasters.
- C. Attach panel brackets securely to walls using anchor devices.
- D. Conceal evidence of drilling, cutting, and fitting to room finish.
- E. Maintain uniform clearance at vertical edge of doors.
- F. Attach panels and pilasters to brackets. Locate head rail joints at pilaster center lines.
- G. Field touch-up of scratches or damaged finish will not be permitted. Replace damaged or scratched materials with new materials.
- H. Install coat hooks in accessible stalls at elevation of 48 inches above finish floor maximum to the top edge of the hook.

3.03 ERECTION TOLERANCES

- A. Maximum Variation From True Position: 1/4 inch.
- B. Maximum Variation From Plumb: 1/8 inch.

3.04 ADJUSTING

- A. Adjust and align hardware to uniform clearance at vertical edge of doors, not exceeding 3/16 inch.
- B. Adjust hinges to position doors in partial opening position when unlatched. Return out-swinging doors to closed position.
- C. Adjust adjacent components for consistency of line or plane.

3.05 CLEANING AND PROTECTION

- A. Clean exposed surfaces of partition systems using materials and methods recommended by manufacturer, and provide protection as necessary to prevent damage during remainder of construction period.
- B. Protect finished work until acceptance. Replace damaged panels as required.

END OF SECTION

SECTION 10 2800
TOILET ACCESSORIES

PART 1 GENERAL

1.01 SECTION INCLUDES

- A. Commercial toilet accessories.
- B. Electric hand/hair dryers.
- C. Utility room accessories.
- D. Installation of Owner furnished accessories.

1.02 RELATED REQUIREMENTS

- A. Section 06 1000: Concealed supports for accessories, including in wall framing and plates and above ceiling framing.
- B. Section 10 2113 - Reinforced Composite Toilet Compartments
- C. Divisions 22 and 26: Pertinent sections specifying plumbing and electrical work.

1.03 REFERENCE STANDARDS

- A. ADA Standards - Americans with Disabilities Act (ADA) Standards for Accessible Design.
- B. C.C.R., Title 24, Part 2, California Building Code for accessibility standards.
- C. Manufacturer's recommendations and specifications.
- D. ASTM A123/A123M - Standard Specification for Zinc (Hot-Dip Galvanized) Coatings on Iron and Steel Products.
- E. ASTM A666 - Standard Specification for Annealed or Cold-Worked Austenitic Stainless Steel Sheet, Strip, Plate, and Flat Bar.
- F. ASTM B456 - Standard Specification for Electrodeposited Coatings of Copper Plus Nickel Plus Chromium and Nickel Plus Chromium.
- G. ASTM C1036 - Standard Specification for Flat Glass.
- H. ASTM C1503 - Standard Specification for Silvered Flat Glass Mirror.

1.04 SUBMITTALS

- A. See Section 01 3300 - Submittals, for submittal procedures.
- B. Product Data: Submit data on accessories describing size, finish, details of function, and attachment methods.
- C. Manufacturer's Installation Instructions: Indicate special procedures and conditions requiring special attention.

1.05 COORDINATION

- A. Coordinate the work with the placement of internal wall reinforcement, concealed ceiling supports, and reinforcement of toilet partitions to receive anchor attachments.

PART 2 PRODUCTS

2.01 MANUFACTURERS

- A. Commercial Toilet, Shower, and Bath Accessories:
 - 1. Bobrick Washroom Equipment, Inc.
 - 2. American Specialties, Inc: www.americanspecialties.com.
 - 3. Bradley Corporation: www.bradleycorp.com/#sle.
 - 4. Tubular Specialties Manufacturing, "TSM".
- B. All items of each type to be made by the same manufacturer.

2.02 MATERIALS

- A. Accessories - General: Shop assembled, free of dents and scratches and packaged complete with anchors and fittings, steel anchor plates, adapters, and anchor components for installation.
 - 1. Grind welded joints smooth.
 - 2. Fabricate units made of metal sheet of seamless sheets, with flat surfaces.
- B. Keys: Provide 2 keys for each accessory to Owner; master key lockable accessories.
- C. Mirror Glass: Annealed float glass, ASTM C1036 Type I, Class 1, Quality Q2, with silvering, protective and physical characteristics complying with ASTM C1503.
- D. Adhesive: Two component epoxy type, waterproof.
- E. Fasteners, Screws, and Bolts: Hot dip galvanized; tamper-proof; security type.

2.03 FINISHES

- A. Stainless Steel: Satin finish, unless otherwise noted.
- B. Back paint components where contact is made with building finishes to prevent electrolysis.

2.04 Commercial Toilet Accessories

- A. Toilet Paper Dispenser: Double roll, surface mounted, for coreless type rolls.
 - 1. Products:
 - a. Product: B2888 manufactured by Bobrick.
 - b. Substitutions: Section 01 6000 - Product Requirements.
- B. Toilet Paper Dispenser: Double roll, semi-recessed, for coreless type rolls.
 - 1. Products:
 - a. Product: B3888 manufactured by Bobrick.
 - b. Substitutions: Section 01 6000 - Product Requirements.
- C. Soap Dispenser: Liquid soap dispenser, wall-mounted, surface, with stainless steel cover and horizontal stainless steel tank and working parts; push type soap valve, check valve, and window gage refill indicator, tumbler lock.
 - 1. Minimum Capacity: 40 ounces.
- D. Mirrors: Stainless steel framed, 1/4 inch thick annealed float glass; ASTM C1036.
 - 1. Size: as indicated.
 - 2. Frame: 0.05 inch angle shapes, with mitered and welded and ground corners, and tamperproof hanging system; satin finish.
 - 3. Product: B-2908 manufactured by Bobrick.
- E. Seat Cover Dispenser: Stainless steel, surface-mounted, reloading by concealed opening at base, tumbler lock.

1. Minimum capacity: 250 seat covers.
- F. Grab Bars: Stainless steel, 1-1/4 min. to 2 max. inches outside diameter, minimum 0.05 inch wall thickness, concealed flange mounting; 1-1/2 inches clearance between wall and inside of grab bar.
 1. Conform to CBC accessibility requirements and referenced standards, support vertical loading of 400 pounds and horizontal loading of 200 pounds applied at any portion of the bar.
 2. Length and configuration: As indicated on drawings.
 3. Product: B5806 manufactured by Bobrick.
- G. Sanitary Napkin Disposal Unit: Stainless steel, surface-mounted, self-closing door, locking bottom panel with full-length stainless steel piano-type hinge, removable receptacle.
 1. Product: B-353 manufactured by Bobrick, recessed mounted.
- H. Sanitary Napkin Disposal Unit: Stainless steel, semi-recessed, self-closing door, locking bottom panel with full-length stainless steel piano-type hinge, removable receptacle.
 1. Product: B-353, manufactured by Bobrick.
 2. Product: 4722-10-15 manufactured by Bradley.
- I. Hand / Hair Dryers: Stainless Steel 18 gauge min. type 304 cover recess mounted. Motor: heavy duty, 5500 RPM, double insulated, CSA and UL component approved, 120V AC, 60HZ. Fan rotor delivering 5200 lfm. Heating Element: 1.25 KW heavy-duty, thermally protected to cut at 90degrees C. Activation by push button.
 1. Product: Electric Aire Model B manufactured by World Dryer Corporation.
- J. Coat Hooks: Doors of single occupancy toilet rooms. Stainless steel, bright polished finish, Bobrick B-682, 6-1/4 inch high, projection 3 inches.
 1. Mount coat hooks at 48" above finish floor in single occupancy toilet rooms and accessible stalls.

2.05 Utility Room Accessories

- A. Mop and Broom Holder: 0.05 inch thick stainless steel, Type 304, hat-shaped channel.
 1. Holders: 3 spring-loaded rubber cam holders.
 2. Length: Manufacturer's standard length for number of holders.
- B. Hook Strip: 0.05 inch thick stainless steel, Type 304, surface mounted
 1. Hooks: 3 stainless steel with satin finish, attached to mounting strip with two stainless steel screws and hex nuts..
 2. Length: Manufacturer's standard length for number of holders.
 3. Product: B-232 manufactured by Bobrick.

PART 3 EXECUTION

3.01 EXAMINATION

- A. Verify existing conditions before starting work.
- B. Verify exact location of accessories for installation. Conform to referenced standards and applicable codes.
- C. Verify that field measurements are as indicated on drawings.

3.02 PREPARATION

- A. Provide templates and rough-in measurements as required.

3.03 INSTALLATION

- A. Install accessories in accordance with manufacturers' instructions in locations indicated on drawings.
- B. Install plumb and level, securely and rigidly anchored to substrate.

Project Name
Enter District Name

Project No.1722.00

- C. Mounting Heights: As required by accessibility regulations, unless otherwise indicated.
- D. Mounting Heights and Locations: As required by accessibility regulations and as indicated on drawings

END OF SECTION

**SECTION 10 4400
FIRE PROTECTION SPECIALTIES**

PART 1 GENERAL

1.01 SECTION INCLUDES

- A. Fire extinguishers.
- B. Fire extinguisher cabinets.
- C. Accessories.

1.02 RELATED REQUIREMENTS

- A. Section 01 6116 - Volatile Organic Compound (VOC) Content Restrictions.
- B. Section 01 8113 - Sustainable Design Requirements.
- C. Section 06 1000 - Rough Carpentry: Wood blocking product and execution requirements.
- D. Section 09 9123 - Interior Painting: Field paint finish.

1.03 REFERENCE STANDARDS

- A. ASTM E814 - Standard Test Method for Fire Tests of Through-Penetration Fire Stops.
- B. FM (AG) - FM Approval Guide.
- C. NFPA 10 - Standard for Portable Fire Extinguishers.
- D. UL (DIR) - Online Certifications Directory.
- E. ADA STANDARDS - Americans with disabilities Act (ADA) Standards for Accessible Design; 2010.
- F. California Code of Regulations, Title 24, Part 11, California Green Building Standards Code, "CAL-Green".

1.04 SUBMITTALS

- A. See Section 01 3300 - Submittals, for submittal procedures
- B. Provide complete submittals at the same time as submittals for work in related sections to permit review of complete and integrated systems and assemblies.
- C. CAL-GREEN Submittals: Product Data - VOC Limits: For adhesives sealants, fillers, primers and coatings, documentation including printed statement of VOC contents, comply with limits specified in related section.
- D. Shop Drawings: Indicate cabinet physical dimensions. mounting heights and locations.
- E. Manufacturer's Installation Instructions: Indicate special criteria and wall opening coordination requirements.
- F. Maintenance Data: Include test, refill or recharge schedules and re-certification requirements.

1.05 FIELD CONDITIONS

- A. Do not install extinguishers when ambient temperature may cause freezing of extinguisher ingredients.

PART 2 PRODUCTS

2.01 PERFORMANCE REQUIREMENTS

- A. VOC Limits for adhesives, sealants, fillers, primers and coatings . Comply with limits specified in related section.

2.02 MANUFACTURERS

- A. Fire Extinguishers:
 - 1. Larsen's Manufacturing Company, Minneapolis, MN, www.larsensmfg.com, is specified.
 - 2. Ansul, a Tyco Business; Cleanguard: www.ansul.com/#sle.
 - 3. J. L. Industries, Inc.; a division of Activar Construction Products Group.
 - 4. Potter-Roemer Inc., Cerritos, CA, www.potterroemer.com.
 - 5. Pyro-Chem, a Tyco Business: www.pyrochem.com/#sle.
 - 6. Substitutions: See Section 01 6000 - Product Requirements.
- B. Fire Extinguisher Cabinets and Accessories:
 - 1. Larsen's Manufacturing Co: www.larsensmfg.com/#sle.
 - 2. Potter-Roemer: www.potterroemer.com/#sle.
 - 3. Substitutions: See Section 01 6000 - Product Requirements.

2.03 FIRE EXTINGUISHERS

- A. Fire Extinguishers - General: Comply with product requirements of NFPA 10 and applicable codes, whichever is more stringent.
 - 1. Provide extinguishers labeled by UL (DIR) or FM (AG) for purpose specified and as indicated.
 - 2. Attach manufacturer's standard metal foil label to cylinder, with printing and graphics indicating information and instructions required by local authorities having jurisdiction. Include current certification tag
- B. Multipurpose Dry Chemical Type Fire Extinguishers: Carbon steel tank, with pressure gage.
 - 1. Class: A:B:C type.
 - 2. Size and classification as scheduled.
 - 3. Finish: Baked polyester powder coat, red color.
- C. Dry Chemical Type Fire Extinguishers: Stainless steel tank, with pressure gage.
 - 1. Class: K type.
 - 2. Size and classification as scheduled.
 - 3. Finish: Polished stainless steel.
 - 4. Temperature range: Minus 20 degrees F to 120 degrees F.

2.04 FIRE EXTINGUISHER CABINETS

- A. Fire Rating: Listed and labeled in accordance with ASTM E814 requirements for fire resistance rating of walls where being installed.
- B. Fire Rated Cabinet Construction: One-hour fire rated.
 - 1. Steel; double wall or outer and inner boxes with 5/8 inch thick fire barrier material.
- C. Cabinet Configuration: Surface mounted type. Larsen "Cameo" or equal.
 - 1. Size to accommodate accessories.
 - 2. Trimless type.
 - 3. Provide cabinet enclosure with right angle inside corners and seams, and with formed perimeter trim and door stiles.
- D. Door: 0.036 inch metal thickness, reinforced for flatness and rigidity with nylon catch. Hinge doors for 180 degree opening with two butt hinge.

- E. Door Glazing: Acrylic plastic, clear, 1/8 inch thick, flat shape and set in resilient channel glazing gasket.
- F. Cabinet Mounting Hardware: Appropriate to cabinet, with pre-drilled holes for placement of anchors.
- G. Weld, fill, and grind components smooth.
- H. Finish of Cabinet Exterior Trim and Door: No. 4 - Brushed stainless steel.
- I. Finish of Cabinet Interior: White colored enamel.

2.05 ACCESSORIES

- A. Wall mounting bracket: Type specified in manufacturer's product literature for indicated tank size, with wall anchoring devices for indicated wall type.
- B. Extinguisher Brackets: Formed steel, chrome-plated.

2.06

PART 3 EXECUTION

3.01 EXAMINATION

- A. Verify existing conditions before starting work.
- B. Verify rough openings for cabinet are correctly sized and located.

3.02 INSTALLATION

- A. Install in accordance with manufacturer's instructions.
- B. Coordinate size of fire protection cabinets to ensure that type and capacity of fire extinguishers indicated are accommodated.
- C. Coordinate sizes and locations of fire protection cabinets with wall depths.
- D. General: Install fire protection cabinets in locations and at mounting heights indicated or, if not indicated, at heights below acceptable to authorities having jurisdiction.
 - 1. Fire Protection Cabinets: Install cabinets such that the door handle and fire extinguisher handles are no higher than 40 -inches above finish floor.
 - 3. Verify cabinet projection dimensions and mount in accordance with ADA path-of-travel requirements including vertical clearances and control operation heights.
- E. In fire-rated walls, coordinate cabinet installation to maintain fire rating of wall.
- F. Secure rigidly in place.
- G. Place extinguishers in cabinets.

3.03 ADJUSTING AND CLEANING

- A. Remove temporary protective coverings and strippable films, if any, as fire protection cabinets are installed unless otherwise indicated in manufacturers written installation instructions.
- B. Adjust fire protection cabinet doors to operate easily without binding. Verify that integral locking devices operate properly.
- C. On completion of fire protection cabinet installation, clean interior and exterior surfaces as recommended by manufacturer.

- D. Touch up marred finishes, or replace fire protection specialties that cannot be restored to factory-finished appearance. Use only materials and procedures recommended or furnished by fire protection cabinet and mounting bracket manufacturers.
- E. Replace fire protection specialties that have been damaged or have deteriorated beyond successful repair by finish touchup or similar minor repair procedures.

3.04 SCHEDULES

- A. Location: Concession area, Type K.
- B. Location: Weight Room, Team Room and Storage areas: Type 2A-10-BC.

END OF SECTION

SECTION 11 4000

FOODSERVICE EQUIPMENT

PART 1 GENERAL

1.01 RELATED DOCUMENTS

- A. Drawings and general provisions of the Contract, including General and Supplementary Conditions and Division 1 Specifications Sections, apply to this Section.

1.02 SUMMARY

- A. This section included the following:
 - 1. Foodservice equipment works as indicated on the drawings and by equipment schedule at the end of this section.
 - 2. Drawings, the provisions of the Agreement, the General Conditions, and the Division 1 specifications sections apply to all work of this section.
 - 3. Substitutions: Substitute products will be considered only under the terms and conditions of Division 1.
 - 4. Substitutions: Proposals for alternate products and methods for applications indicated may be considered by the Architect, subject to requirements of Division 1, system performance requirements and applicable PART 1 requirements of this Section.
- B. Related Sections
 - 1. There are no related Sections.

1.03 ACTION SUBMITTALS

- A. Product Data: For each type of product indicated.
- B. Shop Drawings
 - 1. For fabricated equipment. Include plans, elevations, sections, rough-in dimensions, fabrication details, utility service requirements, and attachment to other work.
 - 2. File names shall conform to CSI MasterFormat 2011.

1.04 INFORMATIONAL SUBMITTALS

- A. Coordination Drawings: For foodservice facilities. Drawings are to be submitted in PDF format.
 - 1. Equipment floor plan and schedule.
 - 2. Electrical rough-in plan and schedule.
 - 3. Plumbing rough-in plan and schedule.
 - 4. Elevation drawings of foodservice equipment.
- B. Equipment Spec Books
 - 1. Provide foodservice equipment spec sheets in order of list of kitchen equipment shown in written specifications and labeled with the appropriate item number. Highlight accessories and voltages as appropriate on the spec sheets. If factory spec sheets are not available, indicate relevant information (size, plumbing requirements and electrical requirements) on white sheet. Gather spec sheets from the owner for owner supplied equipment and insert in spec book. Provide in PDF format.

1.05 CLOSEOUT SUBMITTALS

- A. Maintenance Manuals
 - 1. Provide a PDF with the project address and "Foodservice Operation & Maintenance Manuals" on the front page. Include information for each piece of equipment with electrical or gas connections. Information should include operation instructions, cleaning and maintenance instructions, parts listing if available, list of service agencies (names, addresses and phone numbers) authorized to repair the equipment, voltage, gas type, refrigerant used, serial number and copies of the warranties. List should be sorted alphabetically by manufacturer.

1.06 QUALITY ASSURANCE

- A. Certify that all work and materials comply with Federal, State, and Local laws, ordinances and regulations and is confirmed by the local inspector having jurisdiction.
- B. Work and materials must be in full accord and when appropriate, shall be listed with the following agencies:
 - 1. Local Health Department
 - 2. National Sanitation Foundation (N.S.F.)
 - 3. Underwriter Laboratories (U.L.) or ETL equivalent.
 - 4. American Gas Association (A.G.A.)
 - 5. N.F.P.A. - latest edition, for exhaust system.
- C. Qualifications
 - 1. Kitchen Equipment Contractor (KEC) and its sub-contractors to have at least five (5) years experience in this type of work. Upon request provide at least three references for jobs of similar size and content.
 - 2. Commercially manufactured equipment is not acceptable unless evidence is furnished that similar equipment has been operation successfully in a minimum of three (3) installations (excluding testing laboratories, field testing, or prototypes) for at least one (1) year.
 - 3. Commercially manufactured equipment will be reviewed base on submittal data provided on manufacturer's literature and/or manufacturer's shop drawing for prime alternate or substituted items. Failure of the equipment to meet the capacity, operation, size, utility and production as submitted will result in the rejection of the equipment regardless of disclaimers.
 - 4. Custom fabricated equipment shall be manufactured by a foodservice equipment fabricator with at least five (5) years experience in this type of work, who has the plan, personnel, and engineering facilities to properly design, detail and manufacture quality foodservice equipment.
- D. Regulatory Requirements: Install equipment to comply with the following:
 - 1. ASHAE 15, "Safety Code for Mechanical Refrigeration."
 - 2. NFPA 54, "National Fuel Gas Code."
 - 3. NFPA 70, "National Electrical Code."
 - 4. NFPA 96, "Ventilation Control and Fire Protection of Commercial Cooking Operations."

1.07 WARRANTY

- A. All equipment shall be fully guaranteed against defects in workmanship and material for one (1) year after Owner's final acceptance. Refrigeration compressors shall be fully guaranteed for five (5) years. All repairs and replacement shall be made without charge to the Owner. Guarantee period shall commence with the first usage of the equipment for the intended purpose after final acceptance.
- B. Provide a warranty sheet in PDF format listing all the equipment by manufacturer, the model

and serial number of the piece of equipment, and the authorized service agency for each piece of equipment. Include the service agency's phone number and email address.

PART 2 PRODUCTS

2.01 GENERAL REQUIREMENTS OF FABRICATION

- A. Fabrication shall conform to general acceptance of the foodservice industry.
- B. Fabrication shall meet or exceed National Sanitation Foundation standards including the latest editions and revisions.

2.02 MATERIALS

- A. Stainless Steel (S/S): Stainless Steel shall be of U.S. Standard-gauges as indicated, but not less than 18-gauge or as note, Type 304 with No. 4 finish.
- B. Galvanized Steel: Galvanized steel shall be of 14-gauge and shall be electro galvanized. Galvanized steel shall be used in no-exposed areas, areas which have no contact with food or food serving items, and in framework, when used in framework, galvanized steel shall be all welded construction.
- C. Plastic Laminate (PL):
 - 1. Shall be Formica, Parkwood, LaminArt, or approved equal.
 - 2. Shall be veneered with approved waterproof and heatproof cement. Rubber base adhesives are not acceptable.
 - 3. Shall be directly applied over 3/4" plywood.
 - 4. Exposed faces and edges shall be faced with 1/16" thick material. Corresponding backs shall be covered with approved backing and balancing sheet material.
- D. Solid Surface Material (SSM):
 - 1. Shall be Granite, Caesarstone, Silestone or approved equal and installed over 3/4" plywood or metal bases. Provide air space, trim, and/or insulation around any heat or cold producing equipment to guard against discoloration and cracking.

2.03 METAL TOP CONSTRUCTION

- A. Metal tops shall be one-piece 14-gauge welded construction, including field joints. Secure to a full perimeter galvanized steel channel frame crossed-braced not farther than 30 inches on center. Fasten top with stud bolt or tack welds.

2.04 ENCLOSED CABINET BASES

- A. Bases shall be fabricated from not less than 18-gauge steel reinforced by forming the metal ends and shelves. Partitions shall be all stainless steel. The ends and vertical partitions may be of single wall construction, with a 2-inch face, all partitions and sides shall be welded in the intersection and flush with the bottom.
- B. Unexposed backs and structural members may be constructed of galvanized steel.
- C. Intermediate shelves shall be removable, except the bottom shelf when the cabinet is on legs. When the cabinet is on a masonry base, the bottom shelf shall be removable to all access for cleaning.

2.05 LEGS AND CROSS RAILS

- A. Legs and cross railings shall be 1-5/8", 16-gauge stainless steel tubing. All cross rails shall be continuously welded, ground and polished. Tack welds or other methods of connection are not acceptable. Bottoms of legs shall be wedged inward and fitted with a stainless steel bullet type foot, with not less than 2" adjustment. Freestanding legs shall be pegged to the floor with 1/4" stainless steel rod.
- B. Stainless steel gussets shall be not less than 3" diameter at top and 3-3/4" long. Outer shell 16-gauge stainless steel reinforced with 12-gauge mild steel inserts welded interior shell. Gussets shall be large enough to accommodate 1-5/8" tube with provision for Allen screw fastener.
- C. Adjustable foot shall be constructed of stainless steel 1-1/2" diameter tapered at the bottom to 1" diameter, fitted with threaded cold rolled rod for minimum 1-1/2" by 3/4" threaded busing plug welded to legs.

2.06 SHELVES

- A. When shelves are part of the fixture, the following shall apply:
 - 1. Open base type shelf shall be notched around the leg and continuously welded to the leg.
 - 2. Cabinet base type shelf shall be turned up on the back side a minimum of 1/4 inch radius and further slightly to insure a tight fit to enclosure panels.
- B. Wall shelves shall be one-piece 16-gauge welded construction, including field joints. Secure shelves with 14-gauge s/s brackets at 36-inch on-center maximum.
- C. Overshelf shall be one-piece 16-gauge welded construction, including field joints. Secure to 1-inch tubular supports at 60-inch center maximum attached to counter tops.

2.07 SINKS

- A. When multiple compartments are part of the design, they shall be continuous on the exterior without applied facing strips or panels, or separated by a minimum of 2". The bottom of each compartment shall be creased such as to ensure complete drainage to waste opening.
- B. Partitions between compartments shall be double thickness, continuous, and welded.
- C. Where sink bowls are exposed, the exterior shall be polished to a number 4 finish.
- D. Fabricator shall provide drains, wastes, and faucets as indicated on drawings, or itemized specifications.

2.08 OTHER FABRICATED EQUIPMENT

- A. Casters:
 - 1. Shall be heavy-duty type, ball bearing, solid or disc when with non-marking grease-proof rubber, neoprene or polyurethane tire.
 - 2. Wheel shall be 5-inch diameter, minimum wide of tread 1-1/2 inch, with a minimum capacity per caster of 250 lbs.
 - 3. Solid material wheels shall be provided with stainless steel rotating wheel guards.
 - 4. Shall be sanitary, have sealed wheel and swivel bearings and polish plate finish.
- B. Doors:
 - 1. Metal doors shall be double cases stainless steel. Outer pans shall be 18-gauge stainless steel with corners welded, ground smooth, and polished. Inner pan shall be 20-gauge stainless steel fitted tightly into outer pan with a sound deadening material such as Celotex or Styrofoam used as a core. Doors shall finish approximately 3/4 inch thick.

2. Sliding doors shall be mounted on large, quiet ball bearing rollers in 14-gauge stainless steel overhead tracks and be removable without the use of tools. Bottom of cabinet shall have stainless steel guide pins and not channel tracks for doors.
3. Hinged doors shall be mounted on heavy-duty NSF approved hinges, or as noted on plans and specifications.

C. Hardware:

1. Shall be solid heavy-duty type.
2. Door hardware shall be locking type, keyed and master keyed.
3. Shall be identified with manufacturer's name and number so that broken or worn parts may be replaced.
4. Submit samples for approval when requested.
5. Pulls shall be Component Hardware or equal.

D. Drawer Assemblies:

1. Assemblies shall consist of removable drawer body mounted in a ball bearing slide assembly and padlock assembly.
2. Slide assemblies shall consist of one pair of roller bearing extension slides with slide and back enclosure panels, front space angle, and two drawer carrier angles secured to slides and stainless steel front.
3. Slides shall be 250-pound capacity made by Component Hardware or equal.
4. Drawer bodies for general storage shall be 20-inch by 20-inch with Royalite containers.
5. Drawers intended to hold food products shall be removable type with 12-inch by 20-inch stainless steel assembly.
6. Drawer fronts shall be double cased $\frac{3}{4}$ -inch thick, with 18-gauge stainless steel welded and polished front pan. Steel back pan is to be tightly fitted and tack welded.
7. All drawers shall be provided with replaceable soft neoprene bumpers or, for refrigerated drawers, a full perimeter soft gasket.

2.09 FABRICATED WORKMANSHIP

A. Items of specially fabricated equipment shall be fabricated by an acceptable manufacturer, which is NSF approved and fabricated in an approved manner to the complete satisfaction of the owner.

1. Welding and soldering:
 - a. Materials 18-gauge or heavier shall be welded.
 - b. Seams and joints shall be shop welded or soldered as the nature of the material may require.
 - c. Welds shall be ground smooth and polished to match original finish.
 - d. Where galvanizing has been burned off, the weld shall be cleaned and touched up with high-grade aluminum paint.

B. Fasteners and Joints:

1. The following will not be accepted:
 - a. Exposed screw or bolt heads.
 - b. Rivets.
 - c. Butt joints made by riveting straps under seams and then filled with solder.

C. Rolled Edges: Rolled edges shall be as detailed, with corners, bull nose, ground and polished.

D. Coved Corners: All stainless steel foodservice equipment shall have $\frac{1}{2}$ -inch or larger radius coves in all horizontal and vertical corners and intersections per NSF standards.

E. Closures: Where ends of fixtures, backsplashes, shelves, etc. are open, fill by forming the metal, or weld sections, if necessary, to close entire opening flush to walls or adjoining fixtures.

2.10 OPERATION REQUIREMENTS

- A. Insure quiet operation of foodservice and related equipment.
- B. Insure the bumper gaskets stop and any other needed protection is installed on all fabricated equipment as needed.

2.11 COLD STORAGE ROOMS

- A. Pre-fabricated, pre-assembled, sectional size and configuration as shown on plan, and as verified by field dimensions, with largest possible area provided.
- B. Check jobsite before installation of walk-in cooler/freezer to verify proper dimensions for all trim pieces.
- C. General:
 - 1. The urethane foam core of the panels shall be certified by Underwriter's Laboratories having tested and in accordance with UL Standard 723 (ASTM Standard E-84).
 - 2. The foam core of the panels shall be tested in accordance with ASTM Standard D-1929 to determine the self-ignition temperature.
 - 3. Panels shall be tested in accordance with ASTM Standards E-72, E-455 and E-564 for determination of the structural characteristics of the panel system.
 - 4. The foam insulation shall be tested in accordance with ASTM Standard C-177 to evaluate the insulation performance of the material.
 - 5. The urethane foam core must meet the Montreal Protocol for reduction of chlorofluorocarbons (CFCs).
 - 6. Certification of the above performance specifications must be provided by the indicated independent testing laboratory or by any other independent agency recognized by the major model building code agencies UBC, COCA, or the SBBC.
- D. Construction
 - 1. Interior and exterior metal skins formed with steel dies and roll-forming equipment. The metal skins shall be placed into steel molds and liquid urethane injected between them. Urethane shall be foamed in place (poured, not frothed) and, when completely heat-cured, shall bond to the metal skins to form a rigid thick insulated panel.
 - 2. Panels shall be equipped with "Cam-Lok" joining devices. The distance between locks shall not exceed 48-inches, or as specified. Press-fit caps shall be provided to close wrench holes.
 - 3. Exterior and interior finish per itemized specifications.
 - 4. Perimeter door heater shall be fitted with low-conductor, anti-sweat heater wires, fully enclosed in metal, easily replaceable, for freezer compartments.
 - 5. All interior joints covered ¼-inch minimum radius.
 - 6. All conduit and switch/alarm J-boxes to be pre-installed in panel sections with recess splice boxes at exterior ceiling panels.
 - 7. Doors:
 - a. Door to be 36-inch, hinged flush swing type door, or as specified on plans, with 4-inch insulation same as panels. 14-inch by 24-inch view windows in all doors, Heated on freezer doors. Interior and exterior to have 36-inch high diamond tread kick plate.
 - b. Chrome-plated positive door-latch and handle with interior safety release and mortise deadbolt lock assembly.
 - c. Three hinges per door, NSF-approved, chrome plated, self-closing from a 90-degree open position, cam-action.
 - d. Hydraulic door closure equal to Kason 1094.
 - e. All doors accessing walk-ins are to have locks keyed alike.

8. A heated relief port shall be provided at freezer to equalize the difference of pressure between the exterior and walk-in.
9. Kason 1810EZ Fluorescent Light Fixture controlled by interior/exterior light switch (3-way or 4-way).
10. Digital temperature alarm system, with constant "LED" read-out display, audio warning buzzer, and remote sensor, with high-low setting and twisted pair data capability, equal ot Modular Corp. Model #75.

E. Provide permanently mounted trim and closure panels (of material to match exterior panel surfaces) between top of compartments and finished ceiling; and closure strips between wall panels and architectural walls or columns.

2.12 REFRIGERATION SYSTEMS

- A. Provide all refrigeration work through licensed refrigeration contractors.
- B. All refrigeration items shall be designed to maintain the following operating temperatures:
- | | |
|-------------------------------|--------------|
| 1. Walk-in refrigerators | 35 degrees F |
| 2. Walk-in freezers | 0 degrees F |
| 3. Reach-in refrigerators | 35 degrees F |
| 4. Reach-in freezers | 0 degrees F |
| 5. Undercounter refrigerators | 35 degrees F |
| 6. Undercounter freezers | 0 degrees F |
| 7. Cold Pans | 35 degrees F |
- C. An evaporator coil defrost system must be provided by the Contractor on all walk-in refrigerators and freezer rooms operating at less than 35 degrees F.
- D. Hang blower coils per manufacturer's specifications with approved hangers at 4-inches from interior walk-in ceiling. Contractor shall provide a 12-gauge galvanized steel plate of suitable size and shape on the exterior roof of the walk-in box above the coil to support and spread the weight of the coil adequately.
- E. The drain line from freezers shall be wrapped with a continuous electrical heater tape and installed per manufacturer's suggest methods.
- F. Refrigeration tubing shall by Type L. ACR hard drawn degreased, sealed copper and shall be installed with horizontal runs sloped 1-inch per 20-feet towards the condensing units. All refrigerating piping shall be properly supported by adjustable hangers spaced and adjusted to the drop required. Where vertical runs of more than 5-feet occur in the suction line, the risers shall be trapped at the bottom. Piping is to be installed so that the refrigerant or oil cannot drain back into the coil from the suction line.
- G. All suction and refrigerant lines shall be insulated with minimum 1/2-inch Armstrong armaflex or equal cellular type insulation. Metal pipe sleeves shall be provided where piping passes through walls, ceiling, or floors. Space around the tubing shall be filled with mastic insulation compound. Install a permanent suction line filter in each compressor suction line with pressure fitting ahead of the filter to facilitate checking of the pressure drop through the filter. All penetrations through walk-in or freezer walls shall be fully insulated and sealed to be vapor tight to prevent condensation within any light fixtures, switch boxes, junction boxes, or any other fitting. Refrigeration and drain lines shall be fully sealed an provided with escutcheon plates by the installer per attached standard detail or better.
- H. Furnish and completely install a thermostat to control the refrigeration temperatures for each refrigeration compartment. Provide clear dial thermometers mounted flush with each compartment reading in both Fahrenheit and Centigrade.

- I. Control and thermostat wiring is the responsibility of the Contractor, not the electrical contractor. The electrical contractor will provide inter-wiring between the freezer condensing units and freezer blower coils as well as the main power to all disconnect on condensing units and racks.
- J. All refrigeration parts, equipment and labor are the responsibility of the Contractor whether subcontracted or not. All refrigeration sleeves, lines, placements, hangers, insulations, connections and refrigerants are considered parts and must be made available to complete and deliver a fully installed system in working operation at the required temperatures.

2.13 EXHAUST HOODS

- A. All exhaust hoods shall be constructed of stainless steel no less than 18-gauge, type 304. All exposed surfaces shall be a number 4 finish. See plans for size and location of ducts.
- B. All exposed hoods shall be (UL) Underwriter's Listed under the category "Exhaust Hood with Damper", listed with NSF (National Sanitation Foundation), and in accordance with all recommendations of NFPA's Standard #96.
- C. Provide stainless steel enclosure panels to finished ceiling, adjacent walls, and spaces between hoods.
- D. Light fixtures to be incandescent unless otherwise specified.
- E. Bottom of hood to be mounted at 80" above the finished floor.

2.14 FIRE SUPPRESSION SYSTEM

- A. The fire suppression system shall conform to NFPA latest edition.
- B. Provide all surface appliance, hood, and duct protection nozzles.
- C. All exposed piping to be chrome plated or sleeved. Run unexposed wherever possible.
- D. Provide manual pull station. See plans for location.
- E. Provide mechanical gas shut-off valve for equipment below hoods.
- F. Provide testing of the system by the enforcing agency after installation is complete.
- G. The fire suppression system is to be built-into the exhaust hood by the hood manufacturer.

2.15 ENCLOSURES

- A. Provide and install enclosure panels secured or removable for any equipment that houses any equipment with movable parts for access. Also, cover and provide protection for any exposed steam line or condensate line that may be within reach of operating personnel.

2.16 ELECTRICAL WORK - GENERAL REQUIREMENTS

- A. Before ordering equipment confirm with the serving electric utility, all pertinent electrical requirement such as actual voltages available, number of phases and number of wires in the system.

2.17 INSERT PANS

- A. All cut-outs, openings, drawers, or equipment specified or detailed to hold stainless steel insert pans shall be provided with a full complement of pans as follows:
 - 1. One stainless steel, 20-gauge minimum solid insert pan for each space, sized per pans, details, or specifications.
 - 2. Where pan sizes are not indicated in plans, details, or specifications, provide one full size pan for each opening.
 - 3. Provide maximum depth pan to suit application and space.

4. Provide 18-gauge removable stainless steel adapter bars where applicable.

2.18 CORDS AND PLUGS

- A. Where cords and plugs are used, they shall comply with National Electrical Manufacturer's Association (NEMA) requirements.

2.19 WATER FILTERS

- A. Provide filters on all icemakers, beverage equipment, and steamers.

PART 3 EXECUTION

3.01 DELIVERY, STORAGE, AND HANDLING

- A. No provisions are normally made for receipt or storage of any item delivered to the job site before commencement of installation. Contractor is solely responsible for the staging, delivery and safe-keeping of all equipment until turned over to the owner.
- B. Fabricated and commercially manufactured equipment (buy-outs) must be received and accounted for by the Contractor at his warehouse facilities until such time as placement is possible and acceptable by the G.C.
- C. Clearly identify all items by item number and area prior to delivery to the job site.
- D. Under no circumstances shall any individual or agent of the owner, architectural trades, maintenance or security companies be asked to sign for or receive goods, equipment, or services on the job site. Items, parts, optional pieces, trim, or any goods provided under this contract are the responsibility of the contractor whether on the owner's property or in transit until the areas shown in these documents are handed over to the owner or owner's agents.

3.02 INSTALLATION

- A. Contractor shall supervise and direct his work using his best skill and attention. During the installation period, the Contractor shall provide a competent superintendent or foreman for such directions regarding connection, installation, and coordination of all work under the contract.
- B. Installation shall be in strict conformance with referenced standards, the manufacturer's written directions, as shown on the drawings and herein specified. Kitchen equipment shall be installed per the "Guidelines for Seismic Restraints of Kitchen Equipment" by Sheet Metal and Air Conditioning Contractors National Association (SMACNA).
- C. Contractor shall be solely responsible for all construction means, methods, techniques, procedures and coordination of all portions his work under the contract and for coordinating the installations with the General Contractor, so as not to interfere with or delay the overall construction of the project.
- D. Contractor shall verify conditions at the building, particularly door openings, passages, and availability and size of elevators and avoid building any items too large for available openings. Contractor shall provide for the possible necessity of removing and replacing windows or wall panels. Any pieces too bulky for existing facilities shall be hoisted or otherwise handled with apparatus as required. All special handling equipment charges shall be paid by the Contractor.
- E. Floor troughs and drip pans shall be provided by Contractor and installed by the General Contractor. The Contractor shall provide a supervisor for the installation.
- F. Accurately set, scribe, square, level and permanently secure all items in precise position as

indicated on drawings and shop drawings. Exercise extreme care to avoid damaging finished surfaces during the handling and erecting of all items. Repair, replace or otherwise make good all damaged surfaces or blemishes arising from installation in a manner approved by the Owner.

- G. Complete installation with required fastenings, clip angles, braces, anchors and other fittings as required to render the work rigid and secure. Secure wood items with screws or anchor to furring strips to permit removal.
- H. Caulk all items resting on concrete pads to eliminate crevices between item and pad.
- I. Shim level items without legs with stainless steel shims. Caulk watertight to eliminate crevices between item and mounting surfaces on floor.
- J. Seal spaces between all units and walls, ceilings, floor or fixed adjoining units against entrance of food particles or vermin by means of trim strips, welding, soldering, or commercial joint material as suited to the nature of the equipment. Seal and smooth (when not exposed to extreme heat) with General Electric Silicone Construction Sealant Series SE1200 in appropriate color. Width of joints sealed with silicone not to exceed ¼"
- K. Contractor shall do all cutting and fitting on the equipment required by other contractors for access for the piping, conduit, or utility access.
- L. Do not use any exposed bolts, nuts, or screws other than those shown on shop drawings. Any additional and approved bolts, nut, or screws must be stainless steel.
- M. Protect equipment that has been delivered to the job site from damage. Counter and table tops to be covered with plywood, flakeboard or hardboard during the installation period.
- N. Upon completion of installation, clean and polish all surfaces of each item with appropriate materials. At this time, prepare to account to the consultant and Owner for quantities, locations, and conditions of all items.
- O. Should any repairs be required due to the neglect of the other contractors, the repairs must be approved by owner before the work is performed. All extra charges must be approved and all repairs required must be noted in writing before work is performed, stipulating the price and by whom the extra expense is to be paid. In case the Contractor does not secure such extra order, the expense shall be borne by him. No cutting, notching, drilling or altering of any kind shall be done to the building by the Contractor without first obtaining permission from the GC, Owner, or architect.
- P. Throughout the progress of the work, the Contractor shall keep the working area free from debris of all types, and remove from premises all rubbish resulting from any work being done by him. At the completion of work, the Contractor shall leave the premises in a clean and finished condition.

3.03 TRIMMING AND SEALING EQUIPMENT

- A. Any space between units to walls, ceiling, floors, and adjoining units, not portable, shall be completely sealed against entrance of food particles or vermin by means of trim strips, welding soldering, or commercial joint material suitable to the nature of the equipment.
- B. Sealer, when not exposed to extreme heat, shall be silicone construction sealant in appropriate color.
- C. End of hollow sections shall be closed.
- D. Enclosed fixtures without legs mounted on masonry bases or floor shall be sealed watertight to base or floor.

3.04 CUTTING AND FITTING

- A. Provide cutting and fitting required on the equipment by subcontractors to make their work fit.
- B. Should any repairs to foodservice equipment be required due to neglect of other contractors, all extra charges and all anticipated repairs shall be noted in writing before work is performed. In case the Contractor does not follow this procedure, the expense shall be borne by him.
- C. No cutting, notching, drilling, or altering of any kind shall be done to the building without first obtaining permission.

3.05 PROTECTION OF EQUIPMENT

- A. Be responsible during the progress of the project to protect equipment against theft and/or damage until final acceptance by the Owner.
- B. Prefabricated walk-in boxes, on-site and installed in advance of the rest of the equipment, shall not be used for general storage by other trades and shall be locked before leaving the site. Damage and/or theft resulting from failure to secure boxes will be repaired/replaced at Contractor's expense.

3.06 ADJUSTMENT OF EQUIPMENT AND DEMONSTRATION

- A. Turn on all mechanical equipment, test for leaks, poor connections, inadequate or faulty performance and correct if necessary; adjust for proper operation.
 - 1. All thermostatically controlled equipment and equipment with automatic features shall be operated for a sufficient length of time to prove controls are functioning as intended.
- B. At a time and date, selected by the Owner, the Kitchen Equipment Contractor shall arrange for a demonstration of all mechanical equipment for the Owner's representatives. These demonstrations are to be conducted by factory trained representatives of the various equipment manufacturers and shall be done in two stages; one for the kitchen manager and staff and the second for the maintenance personnel. A representative of the Kitchen Equipment Contractor must attend all demonstrations.

3.07 ITEMIZED LIST OF EQUIPMENT

Abbreviations:

| | |
|------|---|
| OFCI | Owner Furnished Contractor Installed |
| CFCI | Contractor Furnished Contractor Installed |
| OFOI | Owner Furnished Owner Installed |

| | | | |
|---------|----------------------|------------|------|
| ITEM 1: | DRY STORAGE SHELVING | QTY: 1 Lot | CFCI |
|---------|----------------------|------------|------|

Manufacturer: Metro
 Model: Super Erecta - Brite Finish

1. Dry storage shelving, quantity and sizes per plan.
2. Provide shelving units 74" high, with four shelves per unit.
3. Provide with seismic feet and wall clamps.

| | | | |
|---------|-------------|--------|------|
| ITEM 2: | ICE MACHINE | QTY: 1 | CFCI |
|---------|-------------|--------|------|

Manufacturer: Manitowoc
 Model: IY-0454A

1. Self-contained ice cuber, half-dice cubes.
2. 120 volt.
3. Provide with B-400 bin.
4. Provide with Everpure EV932473 water filter assembly.

| | | | |
|---------|---------|--------|------|
| ITEM 3: | FREEZER | QTY: 1 | CFCI |
|---------|---------|--------|------|

Manufacturer: True
 Model: T-23F-HC

1. 1-door reach-in freezer.
2. 115 volt.
3. On locking casters.
4. Door hinged right.

| | | | |
|---------|-----------|--------|------|
| ITEM 4: | WORKTABLE | QTY: 1 | CFCI |
|---------|-----------|--------|------|

Manufacturer: Custom
 Model: Custom

1. S/S worktable, size and shape per plan, with s/s legs and undershelf, with splash at rear and left end.

| | | | |
|---------|----------|--------|------|
| ITEM 5: | POT SINK | QTY: 1 | CFCI |
|---------|----------|--------|------|

Manufacturer: Select Stainless
 Model: 3B1618-2D18

1. S/S 3-tub pot sink per manufacturers specs, (3) 16" x18" x 12" deep sinks with center drains and lever waste assemblies, splash at wall, return splash on right end, s/s legs and rear cross bracing.
2. See elevations drawings.

| | | | |
|---------|--------|--------|------|
| ITEM 6: | FAUCET | QTY: 2 | CFCI |
|---------|--------|--------|------|

- Manufacturer: T&S Brass
Model: B-0231
1. Splashmount faucet with 12" nozzle.
 2. Provide with B-0230-Kit installation kit.

| | | | |
|---------|------------|--------|------|
| ITEM 7: | WALL SHELF | QTY: 1 | CFCI |
|---------|------------|--------|------|

- Manufacturer: Select Stainless
Model: 6WS-12
1. 72" x 12" with wall mounting bracket.
 2. See elevation drawings.

| | | | |
|---------|--------------|--|--|
| ITEM 8: | SPARE NUMBER | | |
|---------|--------------|--|--|

| | | | |
|---------|--------------|--|--|
| ITEM 9: | SPARE NUMBER | | |
|---------|--------------|--|--|

| | | | |
|----------|--------------|--|--|
| ITEM 10: | SPARE NUMBER | | |
|----------|--------------|--|--|

| | | | |
|----------|-----------|--------|------|
| ITEM 11: | HAND SINK | QTY: 1 | CFCI |
|----------|-----------|--------|------|

- Manufacturer: Advance
Model: 7-PS-60
1. S/S hand sink.
 2. Provide with 7-PS-17 side splashes on both sides.
 3. Provide with 7-PS-36 wall brackets.

| | | | |
|----------|-------------------------|--------|------|
| ITEM 12: | SOAP & TOWEL DISPENSERS | QTY: 1 | OFOI |
|----------|-------------------------|--------|------|

Provided by the district.

| | | | |
|----------|--------------|--------|------|
| ITEM 13: | REFRIGERATOR | QTY: 1 | CFCI |
|----------|--------------|--------|------|

- Manufacturer: Beverage Air
Model: HBR49HC-1-G
1. 2-door refrigerator with glass doors.
 2. 115 volt.
 3. On locking casters.
 4. Standard door hinging.

| | | | |
|----------|-----------|--------|------|
| ITEM 14: | WORKTABLE | QTY: 1 | CFCI |
|----------|-----------|--------|------|

- Manufacturer: Custom
Model: Custom
1. S/S worktable, size and shape per plan, with s/s legs and undershelf, with splash at wall.

| | | | |
|----------|---------------|--------|------|
| ITEM 15: | COFFEE BREWER | QTY: 1 | CFCI |
|----------|---------------|--------|------|

- Manufacturer: Bunn
Model: Dual GPR
1. 120-208 volt.
 2. Provide with 39000.0005 water filter.
 3. Provide with (2) GPR servers.

| | | | |
|----------|-----------------------|--------|------|
| ITEM 16: | HOT CHOCOLATE MACHINE | QTY: 1 | CFCI |
|----------|-----------------------|--------|------|

- Manufacturer: Bunn
Model: DBC-3
1. 120 volt.
 2. Provide with 39000.0004 water filter.

| | | | |
|----------|----------------|--------|------|
| ITEM 17: | MICROWAVE OVEN | QTY: 1 | CFCI |
|----------|----------------|--------|------|

- Manufacturer: ACP
Model: RFS18TS
1. 208-240 volt.
 2. Provide with 2418-MS-1-X s/s wall shelf.

| | | | |
|----------|----------------------|--------|------|
| ITEM 18: | SODA & ICE DISPENSER | QTY: 1 | OFOI |
|----------|----------------------|--------|------|

Provided by the district.

| | | | |
|----------|-----------------|--------|------|
| ITEM 19: | POPCORN MACHINE | QTY: 1 | CFCI |
|----------|-----------------|--------|------|

- Manufacturer: Star
Model: 39-A
1. 120 volt.
 2. 135 1-oz servings per hour.

| | | | |
|----------|-----------------|--------|------|
| ITEM 20: | HOT DOG STEAMER | QTY: 1 | CFCI |
|----------|-----------------|--------|------|

- Manufacturer: Star
Model: 70SSA
1. 120 volt.
 2. 230 hot dog capacity, with 36 bun capacity.

| | | | |
|----------|----------------|--------|------|
| ITEM 21: | WARMER DRAWERS | QTY: 2 | CFCI |
|----------|----------------|--------|------|

- Manufacturer: Alto-Shaam
Model: 500-2D
1. 120 volt.
 2. Provide with 5014559 vented drawers.

| | | | |
|----------|---------------------|--------|------|
| ITEM 22: | NACHO CHEESE WARMER | QTY: 1 | CFCI |
|----------|---------------------|--------|------|

- Manufacturer: Star
Model: 11WLA-HS
1. Nacho cheese warmer/dispenser.
2. 120 volt.

| | | | |
|----------|---------------|--------|------|
| ITEM 23: | CHILI WARMERS | QTY: 2 | CFCI |
|----------|---------------|--------|------|

- Manufacturer: Wells
Model: HW-10
1. Cook 'N Hold warmer.
2. 120 volt.

| | | | |
|----------|--------------------------|--------|------|
| ITEM 24: | MILLWORK SERVING COUNTER | QTY: 1 | CFCI |
|----------|--------------------------|--------|------|

Provided by the GC. See architectural drawings.

END OF SECTION

SECTION 11 5200
AUDIO-VISUAL EQUIPMENT

PART 1 GENERAL

1.01 SECTION INCLUDES

- A. Video Projector Mounting Brackets.
- B. Projection screens.
 - 1. Wall hung manual

1.02 RELATED SECTIONS

- A. Section 01 6116 - Volatile Organic Compound (VOC) Content Restrictions.
- B. Section 06 1000 - Rough Carpentry.
- C. Section 09 2116 - Gypsum Wallboard.
- D. Division 26: Pertinent sections specifying electrical power connections and conduits/raceways for control systems.

1.03 SUBMITTALS

- A. See Section 01 3300 - Submittals, for submittal procedures.
- B. Product Data: Provide brochures, installation instructions.
- C. CAL-GREEN Submittals: Product Data - VOC Limits: For adhesives sealants, fillers, primers and coatings, documentation including printed statement of VOC contents, comply with limits specified in related section.
- D. Shop Drawings: Indicate in large scale detail, drawings of fabricated equipment showing construction methods, type and gage of metal, hardware and fittings, with plan and front elevation..
- E. Warranty: Submit manufacturer warranty and ensure that forms have been completed in Owner 's name and registered with manufacturer.

1.04 DELIVERY, STORAGE, AND PROTECTION

- A. Deliver products to site and store in enclosed areas protected from the weather.

1.05 PROJECT CONDITIONS

- A. Coordinate installation with size, location and installation of service utilities.
- B. Sequence installation to ensure utility connections are achieved in an orderly and expeditious manner.

PART 2 PRODUCTS

2.01 PERFORMANCE REQUIREMENTS

- A. VOC Limits for adhesives, sealants, fillers, primers and coatings . Comply with limits specified in related section.

2.02 VIDEO PROJECTOR MOUNTING BRACKETS

- A. Video Projector Mounts - General: Accommodate maximum dimensions overall 17"W x 27"D x 16"H.Projector; held in place by 14-gauge minimum steel arms; allow air flow and access to functions on all sides of the projector. Mount shall have roll, pitch and yaw adjustments to fine tune projector alignment. Hanger support system allows one-man installation, allowing projector mounting right-

side up or upside down. Mount shall easily re-adjust for exchanging projectors. Finished in Black powder paint.

1. Ceiling Mounted Suspended Type: . Provide with manufacturer standard 1-1/2 inch diameter black pipe and ceiling mounting brackets, rods and accessories required to suit applications indicated.

2.03 MANUAL OPERATION PROJECTION SCREENS

- A. Projection screens for map rail or wall bracket installation.
 1. Matte White viewing surface, flame retardant, mildew resistant.
 2. Standard case and mounting brackets.
 3. Size: Viewing/Projection Area 70 inches x 70 inches.
- B. Accessories
 1. Wall Brackets: 6 inch, non-adjustable extension brackets. Provide for locations where surface mounting of screens is not feasible.
- C. Manufacturers:
 1. Da-Lite "Model B" series is specified, www.da-lite.com.
 2. Draper, www.draperinc.com.
 3. Substitutions: See Section 01 6000 - Product Requirements.

PART 3 EXECUTION

3.01 EXAMINATION

- A. Verify that ventilation outlets, service connections, and supports are correct and in scheduled location.
- B. Verify projector focal range prior to final location of projector mounts and/or projector screen. Obtain Owner's written acceptance of positioning for each condition prior to installation.
- C. Correct unsatisfactory conditions prior to beginning installation.
- D. Beginning of installation means acceptance of existing conditions.

3.02 INSTALLATION

- A. Install in accordance with manufacturer's instructions.
- B. Use anchoring devices provided or required by the manufacturer.

3.03 INTERFACE WITH OTHER WORK

- A. Television Monitor Brackets Coordinate wood framing and gypsumboard with installation of backing plates.
 1. Cut, fit and patch where necessary. Coordinate work with others.

3.04 ADJUSTING

- A. Clean and adjust equipment and apparatus to ensure proper working order and conditions.
- B. Adjust limit switches of motorized screens as appropriate for project conditions. Do not allow extended screens to touch floor.

3.05 CLEANING

- A. Remove masking or protective covering from finished surfaces. Wash and clean equipment
- B. Protect installed equipment from subsequent construction operations.

END OF SECTION

**SECTION 12 3600
COUNTERTOPS**

PART 1 GENERAL

1.01 SECTION INCLUDES

- A. Wall-hung countertops.

1.02 REFERENCE STANDARDS

- A. ANSI A208.1 - American National Standard for Particleboard.
- B. ANSI A208.2 - American National Standard for Medium Density Fiberboard for Interior Use.
- C. ASTM E84 - Standard Test Method for Surface Burning Characteristics of Building Materials.
- D. AWI/AWMAC/WI (AWS) - Architectural Woodwork Standards.
- E. AWMAC/WI (NAAWS) - North American Architectural Woodwork Standards, U.S. Version 3.0.
- F. California Code of Regulations, Title 24, Part 2, California Building Code (CBC), International Building Code.
- G. California Code of Regulations, Title 24, Part 11 California Green Building Standards Code, "CAL-Green".
- H. NEMA LD 3 - High-Pressure Decorative Laminates.
- I. PS 1 - Structural Plywood.
- J. WI (CCP) - Certified Compliance Program (CCP).
- K. AWI/AWMAC/WI - Architectural Woodwork Standards (AWS)

1.03 SUBMITTALS

- A. See Section 01 3300 - Submittals, for submittal procedures.
- B. Provide complete submittals at the same time as submittals for work in related sections to permit review of complete and integrated systems and assemblies.
- C. Product Data: Demonstrate compliance with specified attributes, provide Manufacturer's data sheets on each product to be used, including:
 - 1. Preparation instructions and recommendations.
 - 2. Storage and handling requirements and recommendations.
 - 3. Specimen warranty.
- D. CAL-GREEN Submittals:
 - 1. Product Data - VOC Limits: For adhesives, sealants, fillers, primers and coatings, documentation including printed statement of VOC contents, comply with limits specified in related section.
 - 2. Composite Wood Formaldehyde Limits: Provide certification that all products meet current CARB Airborne Toxic Control Measure (ATCM) for Composite Wood Formaldehyde Limits by Mandatory Compliance Dates as specified in related section.
- E. Shop Drawings: Complete details of materials and installation; combine with shop drawings of cabinets and casework specified in other sections.
- F. Selection Samples: For each finish product specified, color chips representing manufacturer's full range of available colors and patterns.

- G. Verification Samples: For each finish product specified, minimum size 6 inches square, representing actual product, color, and patterns.
- H. Test Reports: Chemical resistance testing, showing compliance with specified requirements.
- I. Certificate: Submit labels and certificates required by quality assurance and quality control programs.
- J. Installation Instructions: Manufacturer's installation instructions and recommendations.
- K. Maintenance Data: Manufacturer's instructions and recommendations for maintenance and repair of countertop surfaces.

1.04 QUALITY ASSURANCE

- A. Installer Qualifications: Fabricator.
- B. Quality Certification:
 - 1. Provide labels or certificates indicating that the installed work complies with AWI/AWMAC/WI (AWS) or AWMAC/WI (NAAWS) requirements for grade or grades specified.
 - 2. Provide designated labels on shop drawings as required by certification program.
 - 3. Provide designated labels on installed products as required by certification program.
 - 4. Submit certifications upon completion of installation that verifies this work is in compliance with specified requirements.
 - 5. Arrange and pay for inspections required for certification.
 - 6. Replace, repair, or rework all work for which certification is refused.

1.05 DELIVERY, STORAGE, AND HANDLING

- A. Store products in manufacturer's unopened packaging until ready for installation.
- B. Store and dispose of solvent-based materials, and materials used with solvent-based materials, in accordance with requirements of local authorities having jurisdiction.

1.06 FIELD CONDITIONS

- A. Maintain environmental conditions (temperature, humidity, and ventilation) within limits recommended by manufacturer for optimum results. Do not install products under environmental conditions outside manufacturer's absolute limits.

PART 2 PRODUCTS

2.01 PERFORMANCE REQUIREMENTS

- A. VOC Limits for adhesives, sealants, fillers, primers and coatings . Comply with limits specified in related section.
- B. Composite Wood products must meet current CARB Airborne Toxic Control Measure (ATCM) for Composite Wood Formaldehyde Limits by Mandatory Compliance Dates as specified in Section 01 6116.

2.02 COUNTERTOPS

- A. Quality Standard: See Section 06 4100.
- B. Plastic Laminate Countertops: High-pressure decorative laminate (HPDL) sheet bonded to substrate.
 - 1. Laminate Sheet: NEMA LD 3, Grade HGS, 0.048 inch nominal thickness.
 - a. Surface Burning Characteristics: Flame spread index of 25, maximum; smoke developed index of 450, maximum; when tested in accordance with ASTM E84.
 - b. NSF approved for food contact.

- c. Wear Resistance: In addition to specified grade, comply with NEMA LD 3 High Wear Grade requirements for wear resistance.
 - d. Finish: Matte or suede, gloss rating of 5 to 20.
 - e. Manufacturers: Selected from those listed in Section 06 4100. Provide all materials from a single manufacturer.
2. Exposed Edge Treatment: Square, substrate built up to minimum 1-1/4 inch thick; covered with matching laminate.
 3. Back and End Splashes: Same material, same construction.

2.03 MATERIALS

- A. Wood-Based Components:
 1. Wood fabricated from old growth timber is not permitted.
- B. Plywood for Supporting Substrate: PS 1 Exterior Grade, A-C veneer grade, minimum 5-ply; minimum 3/4 inch thick; join lengths using metal splines.
- C. Particleboard for Supporting Substrate: ANSI A208.1 Grade 2-M-2, 45 pcf minimum density; minimum 3/4 inch thick; join lengths using metal splines.
- D. Medium Density Fiberboard for Supporting Substrate: ANSI A208.2.
 1. Type specified in Section 06 4100.
- E. Adhesives: Chemical resistant waterproof adhesive as recommended by manufacturer of materials being joined.
- F. Countertop Support Brackets: Provide at locations where countertop span is not supported by base cabinet, maximum 36 inches on center.
 1. Steel, welded construction, powder coat finish, color selected by Architect.
 2. Support Arms: Match countertop depth, 2 inch flanges, extended concealed arm predrilled for bolting to wall studs or other support.
 3. A&M Hardware, Inc. 2.0 inch Concealed Brackets: www.AandMhardware.com.
 4. Substitutions: See Section 01 6000 - Product Requirements.
- G. Joint Sealant: Mildew-resistant silicone sealant, color-matched to countertop, clear at stainless steel.

2.04 FABRICATION

- A. Fabricate in accordance with standards governing fabrication quality that are specified in Section 06 4100.
- B. Fabricate tops and splashes in the largest sections practicable, with top surface of joints flush.
 1. Join lengths of tops using best method recommended by manufacturer.
 2. Fabricate to overhang fronts and ends of cabinets 1 inch except where top butts against cabinet or wall.
 3. Prepare all cutouts accurately to size; replace tops having improperly dimensioned or unnecessary cutouts or fixture holes.
 4. Locate openings accurately and use templates or roughing-in diagrams to provide accurate size and shape.
 5. Smooth edges of cutoffs and, where located in countertops and similar exposures, seal edges of cutouts with a water resistant coating.
- C. Provide back/end splash wherever counter edge abuts vertical surface unless otherwise indicated.
 1. Secure to countertop with concealed fasteners and with contact surfaces set in waterproof glue.
 2. Height: 4 inches, unless otherwise indicated.

- D. Epoxy and Solid Surfacing: Fabricate tops up to 144 inches long in one piece; join pieces with adhesive sealant in accordance with manufacturer's recommendations and instructions.
- E. Wall-Mounted Counters: Provide skirts, aprons, brackets, and braces as indicated on drawings, finished to match.
- F. Grommets: plastic material for cut-outs, 2 inch diameter minimum, color as selected.

PART 3 EXECUTION

3.01 EXAMINATION

- A. Do not begin installation until substrates have been properly prepared.
- B. If substrate preparation is the responsibility of another installer, notify Architect of unsatisfactory preparation before proceeding.
- C. Verify that wall surfaces have been finished and mechanical and electrical services and outlets are installed in proper locations.

3.02 PREPARATION

- A. Clean surfaces thoroughly prior to installation.
- B. Prepare surfaces using the methods recommended by the manufacturer for achieving the best result for the substrate under the project conditions.

3.03 INSTALLATION

- A. Install concealed support brackets before wall finishes are applied. Install at spacings indicated on Drawings, except if none are shown, install at maximum 36 inches on center.
- B. Securely attach countertops to cabinets or concealed brackets using concealed fasteners. Make flat surfaces level; shim where required.
- C. Attach plastic laminate countertops using screws with minimum penetration into substrate board of 5/8 inch.
- D. Seal joint between back/end splashes and vertical surfaces.

3.04 TOLERANCES

- A. Variation From Horizontal: 1/8 inch in 10 feet, maximum.
- B. Offset From Wall, Countertops: 1/8 inch maximum; 1/16 inch minimum.
- C. Field Joints: 1/8 inch wide, maximum.

3.05 CLEANING

3.06 PROTECTION

- A. Protect installed products until completion of project.
- B. Touch-up, repair or replace damaged products before Date of Substantial Completion.

END OF SECTION

SECTION 13 3430

PRE-ENGINEERED GRANDSTANDS AND PRESSBOX

PART 1 GENERAL

1.01 SECTION INCLUDES

- A. Pre-Engineered Elevated Grandstands and Pressbox on concrete foundation.

1.02 RELATED SECTIONS

- A. Section 01401 - Testing and Inspections.
- B. Section 03 3000 - Cast-In-Place Concrete.
- C. Division 26 through 28: Pertinent sections specifying electrical and signal systems.

1.03 REFERENCES

- A. Manufacturer's recommendations and specifications.
- A. B. California Code of Regulations, Title 24, latest adopted edition (herein noted as CBC): Chapter 22A Steel.
- B. American Institute of Steel Construction (AISC) 303 "Code of Standard Practice for Steel Buildings and Bridges".
- C. AISC 341 "Seismic Provisions for Structural Steel Buildings".
- D. AISC 358 "Prequalified Connection for Special and Intermediate Steel Moment Frames for Seismic Applications".
- E. AISC 360 "Specification for Structural Steel Buildings".
- F. American Welding Society (AWS) D1.1 "Structural Welding Code - Steel".
- G. AWS D1.8 "Structural Welding Code - Seismic Supplement".
- H. Research Council on Structural Connections (RCSC) "Specification for Structural Joints Using High-Strength Bolts".
- I. Underwriters Laboratories (UL) FRD "Fire Resistance Directory".
- D. AWI Standards: D1.1; D1.3.
- E. NFPA Standard: 102
- F. ASTM B 209 - Standard Specification for Aluminum and Aluminum-Alloy Sheet and Plate.
- G. ASTM B 221 - Standard Specification for Aluminum and Aluminum-Alloy Extruded Bars, Rods, Wire, Profiles, and Tubes.

1.04 DESIGN REQUIREMENTS

- A. Design structural systems to conform to all requirements of DSA IR (Interpretation of Regulations).
- B. Seismic Loads: Design and size components to withstand seismic loads and sway displacement as calculated in accordance with California Building Code and DSA IR.
- C. Structurally stable system; steel; capable of resisting dead load of seating system, plus:.

1. Live Load: 100 lbs/square foot gross horizontal projection.
 2. Live load of Seat and Tread Plank: 120 pounds/lineal foot.
 3. Lateral sway load of Seat Plank: 24 pounds/lineal foot.
 4. Perpendicular Sway load of Seat Plank: 10 pounds/lineal foot.
 5. Handrail/Guardrail: 100 pounds/lineal foot vertical and 50 pounds per lineal foot horizontal. 200 pounds point load.
 6. Snow Loads: As per current CBC requirements.
 7. Wind Loads: As per current CBC requirements.
 8. Seismic Loads: As per current CBC requirements.
 9. Assure positive engagement and alignment of all supports.
- D. Must meet or exceed all State and Local applicable codes and in compliance with the California Building Code.
- E. All openings between seat board and footboard located more than 30 inches above finish grade shall not allow passage of a 4 diameter sphere. The triangular areas created by the bottom guardrail, tread and riser shall not allow passage of a 6 inch sphere.

1.05 SUBMITTALS

- A. See Section 01300 - Submittals, for submittal procedures.
- B. Division of the State Architect Deferred Approval Submittal Requirements:
1. This section specifies work that is a Division of the State Architect deferred approval item. All Engineering calculations and Shop Drawings require review and approval by the Division of the State Architect prior to fabrication or installation. Deferred Approval review provisions of Section 01300 apply to the submittals of this section.
 2. Submit items for deferred approval complete with all structural calculations, test data and information as specified or as subsequently required by the reviewing agency, including engineering stamps and signatures as required. Architect shall submit to DSA only following Architect/Engineer review.
 - a. The Architect will not approve deferred approval submittals until they are approved by DSA.
 3. No work or fabrication shall begin until DSA approved submittals are distributed to the Contractor.
 4. Contractor is notified that significant lead time is required for deferred approval review by ORS and shall schedule submittals accordingly. No extension of Contract Time will be allowed for delays incurred by deferred approval review.
 - a. The Architect is not responsible for DSA delays in deferred approval review.
 5. Submit Certification of Compliance and all other documentation as required by Division of the State Architect.
 6. Make all changes and revisions required by Division of State Architect to obtain approval at no additional costs or extension of time.
- C. Product Data: Provide material types and finishes, indicate compliance with specified options.
1. Structural steel primer paint.
- D. Shop Drawings: Indicate construction and installation.
1. Section layout for each bank of bleachers.
 2. Include seat heights, row spacing and rise, aisle widths and locations, assembled dimensions and anchorages. Indicate
 3. Indicate material and component profiles, sizes, connection attachments, reinforcing, anchor bolt layout and spacing, size, material and type of fasteners, and accessories. Include erection drawings, elevations, and details where applicable.
 4. Include details of cuts, connections, camber, holes, and other pertinent data.
 5. Indicate welded connections using standard AWS A2.4 welding symbols. Indicate net weld

lengths, sizes and types.

- E. Samples: All finished surfaces which are visible under normal use. Demonstrate final texture and color.
- F. DSA Deferred Approval Structural Engineering Calculations: Submit for all components, concrete foundations and assemblies; signed and stamped by a California licensed Structural Engineer.
- G. Revise and resubmit shop drawings and calculations as required by Architect or DSA.
- H. Proof of qualifications for manufacturer and installer: Submit DSA approval and file and application numbers for at least five (5) previous projects within the past five years.
- I. Manufacturer's data: Submit certified copies of the following prior to any fabrication. Include laboratory test reports and other data as required to show compliance with these specifications, including specified standards.
 - 1. Structural metal, including certified copies of mill reports covering the chemical and physical properties.
- J. Welding procedures: For welding as required in accordance with AWS D1.1, submit prequalified joints.
- K. Warranty: Submit manufacturer warranty and ensure that forms have been completed in Owner's name and registered with manufacturer.

1.06 SUBMITTALS FOR RECORD

- A. Section 01300 - Submittals: Procedures for submittals. Architect will not review these submittals.
- B. Structural calculations with original stamp and signature of Professional Structural Engineer verifying compliance with design criteria and compliance with prevailing codes.
- C. Welders' Certificates: Submit certification for welders employed on the project, verifying AWS qualification within the previous 12 months.
- D. Manufacturer's Verified Reports described in and required by DSA.

1.07 QUALITY ASSURANCE

- A. Regulatory Requirements: Division of the State Architect (DSA).
 - 1. Bleachers are an DSA deferred approval item. Review and approval by the Division of the State Architect of engineering calculations and shop drawings related to all aspects of California Building Code, including structural, accessibility and fire and life safety review and approval before fabrication.
 - 2. Submit Certification of Compliance and other required documentation as required by DSA.
- B. Manufacturer Qualifications: Company specializing in manufacturing products specified in this section, with not less than five years of documented experience.
 - 1. Recognized and approved by the California DSA as a manufacturer of bleacher systems.
 - 2. Aware of all DSA requirements for fabrication and installation of bleacher systems.
 - 3. Have successfully prepared a Deferred Approval submittal to DSA on a minimum of five occasions.
- C. Installer Qualifications: Company specializing in performing the work of this section and approved by manufacturer. Recognized by DSA and regularly engaged in at least three DSA approved bleacher system installations within the past three years.
- D. Design bleachers and concrete foundations under direct supervision of a Professional Structural Engineer experienced in design of this Work and licensed in California.

- E. Welding: Perform all welding with certified operators who have qualified by tests prescribed in the Qualification Procedure of the American Welding Society.
- F. Source Quality Control: Mill Test Certification

1.08 DELIVERY, STORAGE, AND PROTECTION

- A. Comply with pertinent provisions of Section 01600.
- B. Deliver anchor bolts, anchorage devices, sleeves and inserts, which are to be incorporated into other work in ample time to avoid delay.
- C. Store materials to permit easy access for inspection and identification. Store materials off the ground, using pallets, platforms or other supports. Protect metal members, package materials and identifications from deterioration.
- D. Store material to prevent twisting, bending, or abrasion, and to provide ventilation. Slope linear metal fabrications to ensure drainage and prevent standing water.
- E. Prevent contact with materials which may cause discoloration or staining. Clean materials which are discolored or stained.
- F. Replacements: In the event of damage, immediately make repairs and replacements necessary to the approval of the Architect and D.S.A. without change in contract amount or time.

1.09 WARRANTY

- A. See Division 00 – General Conditions.
- B. Warrant products against defects in materials and workmanship and correct any defects not due to ordinary wear or tear or improper use or care, which may develop within five years from the date bleachers are completed and placed in service. This warranty shall not be construed to cover damage resulting from vandalism or improper treatment subsequent to acceptance by the Owner.

PART 2 PRODUCTS

2.01 MANUFACTURERS

- A. Southern Bleacher Co. P.O. Box 1, Graham, TX 76450, 800-433-0912, is specified.
- B. Sturdisteel, P.O. Box 2655, Waco, TX 76702-2655.
- C. Substitutions: See Section 01600 - Product Requirements.
 - 1. Alternate manufacturers seeking to be pre-approved must submit product literature and references (with contact names/numbers) to the Owner 14 days prior to bid date, for five similar size DSA approved projects completed in the past five years.
 - 2. Manufacturers bidding the project must furnish their own submittals and calculations for review and approval by D.S.A. Southern Bleacher's plans and calculations are for their sole usage. Each manufacturer is responsible for all costs related to getting their submittal package DSA approved prior to commencing fabrication.
 - 3. No time extensions to the schedule will be granted awaiting DSA approval of submittals and liquidated damages apply.

2.02 MATERIALS

- A. All steel shall conform to the requirements of DSA IR: All new materials.
 - 1. Minimum Yield Point: 35,000 psi.
 - 2. Minimum Ultimate Tensile Strength: 60,000 psi.

3. Elongation: 15% minimum in two inch gage length.
- B. Framework: Galvanized structural steel, ASTM A-529, hot-dipped galvanized to ASTM A-123. All shop connections are seal welds.
- C. Extruded aluminum: Alloy 6063-T6, wall thickness .094 inch.
 1. Seat Planks, Riser Planks, Step Closures: Clear anodized, 204R1, AA-M10C22A31, Class II finish.
 2. Tread Planks: Mill finish.
 3. Railing: Extruded aluminum alloy, clear anodized, 204R1, AA-M10C22A31, Class II finish.

2.03 MANUFACTURED ITEMS

- A. Southern Bleacher Co. Elevated Horizontal Frame Type Bleachers:
 1. Grandstands and Press Box shall be in full compliance with drawing and all requirement of agencies having jurisdiction.
 2. Rise and Depth Dimensions:
 - a. Vertical Rise per Row: as indicated on drawings.
 - b. Horizontal Depth per Row: as indicated on drawings.
 - c. Seat Height: 17 inches above respective tread.
- B. Stringers: Prefabricated wide flange with steel angle rise and depth fabrications, spaced at 6 foot intervals, connected by crossbraces.
- C. Decking: Anodized aluminum Interlock 2000 system as manufactured by Southern Bleacher, or alternative manufacturer closed deck system that channels collected moisture to controlled drainage.
- D. Seats: Nominal 2 inch by 10 inch anodized aluminum planks with matching aluminum end caps.
- E. Treads: Nominal 2 inch by 13 inch mill finish aluminum planks with matching anodized end caps.
- F. Risers: Two nominal 2 inch by 6 inch anodized aluminum riser planks.
- G. Guardrailing: Two lines of aluminum tube with chainlink panel infill, 42 inches above seat on both sides of bleacher and across back of bleacher. Front rail: 3 lines with chainlink 42 inches above front at access aisle; 26 inches at the front of the front row seating.
- H. Handrails: Aluminum tube, configurations as indicated and as required to comply with referenced standards and prevailing codes.
- I. Entry Steps: Frames with 2 inch by 11 inch aluminum plank with step closure, contrasting aluminum stair nose and 2 line rail, 36 inches above nose of step. Handrails shall extend in the direction of the exit steps 12 inches past the end of the steps. Handrail ends terminate in newel posts.
- J. Front Walkway: Elevations and clear width as indicated.
- K. Aluminum Riser Board Front Façade on field facing side of stand, stairs, and ramps.
- L. Aisle(s): Aisle widths as indicated, with 34 inch high handrail with intermediate rail at approximately 22 inches above tread. Handrails with returned ends are discontinuous to allow access to seating through a break of at least 22 inches and no greater than 36 inch wide space. Ailse steps to have constrasting color aluminum tread nosing.
- M. Wheelchair pocket areas: Sizes and locations indicated and as follows; minimum 66 inches wide. Provide in accordance with seating requirements in CBC Section 1104B.3.
- N. Ramps: Configurations as indicated and as follows;
 1. Slope: 1 inch in 12 inches maximum, not to exceed 2 percent cross slope.
 2. Guardrailings: Aluminum tube 36 inches above ramp tread with intermediate rail at 20 inches. Railing shall be continuous for the full length of the ramp and shall extend in the direction of the

- ramp 12 inches past the end, returning to end on a newel post.
3. 74 inch return landing: Landing to have 3 line 36 inch chainlink infill with rail at 42 inches above front walk plank.
- O. Accessible Public Address / Scorekeeper Station: Provide microphone outlet, spotter system outlet, scoreboard outlets in an accessible location as indicated on the drawings.
- P. Press Box: Manufacturers standard type; roofed and enclosed, size as indicated.
1. Size: Manufacturer's standard 48' by 8', lay-out as indicated on drawings.
 2. Finish:
 - a. Flooring: Anodized aluminum interlock deck system.
 - b. Interior Walls: Gypsum panels with sheet vinyl overlay and resilient vinyl base. Color and finish to be selected by architect from manufacturer's standards.
 - c. Ceiling: 24"x24"x5/8" acoustical tile.
 - d. Counter: Plastic laminate covered countertops. Color: as selected by architect.
 3. Insulation: Provide minimum R-13 batt insulation at all exposed exterior surface panels.
 4. Roof Access: Provide roof hatch, permanently attached access ladder, walking surface, safety railing, power and data hookups at roof.
 5. Security Shutters: Provide and install manufacturer's standard roll-up security shutters over press box windows.
 6. Exterior Finish
 - a. 26 gauge prefinished R-Panel paneling as manufactured by MBCI, Signature 200 color series, or equal.
 - b. Wall panels are attached with #12 TEK screws - 6" O.C. at the top, midpoint and bottom of the panels.
 - c. Lap screws are placed at each end of the panels, at the intermediate supports, and at the mid point between supports (TEK #14).
 - d. All fasteners to be painted same color as exterior paneling.
 7. Roof Structure
 - a. 4 inch x 4 inch x 11 gauge square tubing with maximum spacing of 6 feet on center and 4 inches x 2 1/2 inches x 14 gauge steel "cees" with maximum spacing of 2 feet on center.
 - b. Roof: 1/8 inch four way steel plate roof, continuous welded seams coated with acrylic metal primer as manufactured by Coronado and 36 mils of acrylink roof coating as manufactured by Isothermal Protective Coatings, or equal. Plate is welded on both sides of rafters with 1-1/2 inch long 1/8 inch fillet welds on 12 inch centers.
 - c. Insulation: Poly-encapsulated Formaldehyde-free fiberglass building insulation, R-19 (minimum) 6 inches thick. Batt or roll as manufactured by Johns Manville or equal.
 - d. Cornice: 26 gauge steel prefinished to match metal siding.
 - e. Ceiling: 24 inch x 24 inch x 5/8 inch acoustical lay in ceiling tile with removable tiles, per 2006 IBC or local code, applicable category per seismic zone, (in California per 2007 CBC, applicable category per seismic zone, ref. DSA IR 25-5).
 8. Exterior Door(s)
 - a. Full flush steel construction with hollow or polystyrene core. 18 gauge skin sheets. Dimensions: 3 feet 0 inches x 6 feet 8 inches. Color: Coordinated with press box siding color.
 - b. Steel door frame (16 gauge) complete with 1/2 inch threshold and weather-stripping.
 - c. Door Hardware: Yale 546F Exterior Trim, or equal. Handles shall be lever type that allows operation without tight grasping or twisting of the wrist. Keyed alike locks.
 9. Interior Doors
 - a. Interior Hollow Core Birch Unit. Dimensions: 3 feet 0 inches x 6 feet 8 inches.
 - b. Hardware: Handles shall be lever type that allows operation without tight grasping or twisting of the wrist.

10. Interior Walls
 - a. Framing to be steel galvanized studs (25 gauge) 1 1/4 inch x 3 5/8 inch or 4 inch at maximum 2 feet on center.
 - b. Finishes are to be consistent with all other interior finishes.
11. Windows
 - a. Frame: Extruded aluminum single hung, vertical sliding unit, thermal break.
 - b. Sash: Tilt toward inside for easy cleaning.
 - c. Glazing: Clear tempered panes.
 - d. Dimensions of each unit: Dependent on compartment size. At interior wall locations or structural support locations the dimension between windows shall be no greater than 6 inches.
 - e. Finish: Electrostatically applied acrylic enamel.
12. Work Bench
 - a. 1 inch thick x 21 inch wide clear anodized aluminum work bench supported by 4 inch x 2 1/2 inch x 14 gauge steel. Countertops heights shall be constructed to allow wheelchair usage at all locations.
13. Caulking: Sonneborn NP1 - Polyurethane sealant, all temperature, UV resistant, or equal. Silicone products are not acceptable.
14. Electrical
 - a. Submittal drawing shall indicate devices and circuitry.
 - b. Fixtures: 2-lamp, L.E.D, 2' x 4' lay-in design. Fixtures shall be located above countertop and be maximized to full length of compartment space.
 - c. Wiring to be in EMT, flexible metal conduit or surface raceway. N.E.C. breaker panel to be 100 amp flush or surface mounted on wall with 1 1/4 inch conduit stubbed out bottom of press box or 2 inch rigid conduit to be stubbed out at back wall of press box ready for service line to be connected. (Service line to Press Box is responsibility of Owner).
 - d. Electrical outlet(s) installed per NEC shall be standard duty. All outlets shall be surface or flush mounted.
 - e. Sound, Telephone, Clock, Field Communication: Empty single or double outlet boxes (as required) per N.E.C. with 3/4 inch conduit stubbed out bottom of Press Box for use of Owner. Outlet boxes to be flush mounted into wall. Any wiring completed on-site will be responsibility of such contractor for inspections. Quantity. Two will be provided. Owner shall indicate additional boxes needed.
 - f. Filming Area/Observation Deck: Weathertight outlet box for cameras. Quantity: One. Owner shall indicate additional outlets needed.
15. Filming Area/Observation Deck
 - a. Access
 - i. Interior: Roof hatch with OSHA-rated aluminum ladder mounted to an interior back wall.
 - b. Roof guard railing to be 42" above walking surface around perimeter of deck attached to 5/8 inch galvanized studs to be welded to roof support structure. The guard railing to include anodized aluminum with 9 gauge galvanized chain link fencing fastened in place with galvanized fasteners and aluminum ties.

2.04 ACCESSORIES

- A. Channel End Caps: Aluminum alloy 6063-T6, clear anodized 204R1, AA-M10C22A31, Class II.
- B. Hardware and fasteners: Nuts, bolts, hot dipped galvanized.
- C. Hold-down clip assemblies: Aluminum alloy 6061-T6.
- D. Structural Hardware: Equal to or greater than hot dipped galvanized ASTM A307. No connections utilizing high strength bolts are classed as slip critical.

- E. Guardrailings: Anodized aluminum tubing, 1-5/8 inch outside diameter, maximum, with galvanized chain-link infill..
- F. Handrails: Anodized aluminum tubing, 1-1/2 inch outside diameter.
- G. Crossbraces: Extruded aluminum angle, alloy 6061-T6, mill finish.
- H. Aisle nose and stair nose: Aluminum alloy, 6063-T6, black powder coated finish, or other paint system meeting AAMA 603.8-92 specifications with a hardness rating of 2H.
- I. Welding Materials: AWS D1.1; type required for materials being welded. Comply with AWS D1.1, D1.3 and CBC Title 24 Part 2.
- J. Non-shrink Grout for Guardrail post inserts: Masterflow 928 Grout by Master Builders or equal.
- K. Touch-Up Primer for Galvanized Surfaces: SSPC-Paint 20, Type I - Inorganic.
- L. Accessible Seating Designation Signs: Manufacturer's standard plastic signs, 4 inches x 5 inches x 1/8 inch, blue with white etched letters and international symbol with wording as follows: "Accessible Seating, Please Relinquish Seats to Persons With Disabilities and Companions". Provide one sign for each wheel chair and each companion location.

2.05 MIXES

- A. Manufacturer's Engineer shall design foundation concrete mix(es).
- B. Materials: Types specified in Section 03 3000.

2.06 FABRICATION

- A. Field Measurements: Take field measurements prior to preparation of shop drawings and fabrication, where possible, to ensure proper fitting of the work. Allow for trimming and fitting where field conditions preclude accurate measurements or where final dimensions cannot be established prior to fabrication.
- B. Fit and shop assemble items in largest practical sections, for delivery to site.
 - 1. Minimize field splicing and site assembly. Disassemble only to the extent necessary for shipping and handling limitations. Clearly mark units for reassembly and coordinated installation.
 - 2. Complete assembly, including welding, before start of finishing operations. Provide finish surfaces of members exposed in the final structure free of markings, burrs, and other defects.
 - 3. Use materials and items necessary to complete the work, using the best materials and methods ordinarily used for this type of work whether explicitly specified, indicated and detailed or not.
- C. Fabricate items with joints tightly fitted and secured.
- D. Continuously seal joined members by continuous welds.
 - 1. Grind exposed joints flush and smooth with adjacent finish surface. Make exposed joints butt tight, flush, and hairline. Ease exposed edges to small uniform radius.
 - 2. Exposed Mechanical Fastenings: Flush countersunk screws or bolts; unobtrusively located; consistent with design of component, except where specifically noted otherwise.
 - 3. Supply components required for anchorage of fabrications. Fabricate anchors and related components of same material and finish as fabrication, except where specifically noted otherwise.
- E. Use only materials smooth and free of blemishes including pitting, seam marks, roller marks, trade names and roughness.
- F. Fabricate steel members in accordance with drawings and as recommended by A.I.S.C. Verify all dimensions with field conditions prior to fabrication.
 - 1. Clean, prepare and shop-prime steel members. Do not prime surfaces to be field welded or in direct contact with concrete.

2. Galvanizing: ASTM A153, ASTM A123; all steel exposed to weather.
 3. Cutting and drilling: Provide holes for fabrication and for attachment of work specified elsewhere. Countersink holes for bolts and screws.
- G. Welding: Comply with the AWS Structural Welding Code, and with the following:
1. Welds shall be free from excessive oxides, nonmetallic inclusions, and gas pockets.
 2. Welds shall be uniform in section, smooth in weld metal, featheredged, without overlaps.
 3. Surfaces to be welded shall be free from loose scale, rust, paint, or other foreign matter.
 4. Tack welds located in way of design welds shall be melted out when encountered in final welding, or shall be thoroughly fused in with final weld.
 5. Use proper care and procedures to minimize locked-in stress and distortion.
 6. Welder qualification requirements, welding procedure and welding electrodes shall conform to C.B.C. 2209 and most recent editions of AWS D1.1, D1.3; Uniform Building Code Standards Divisions No. V, and IX.
- H. Where splicing is necessary, two internal plank sleeves shall be inserted a minimum of 9 inches into each plank. Provide supporting calculations by design structural engineer showing that the use of splice sleeves will not negatively influence the integrity of the plank.
- I. Hot-dip galvanize steel components following fabrication.

2.07 HANDRAILS AND RAILINGS

- A. Tube railings: Fabricate to dimensions and details shown, with welded joints ground smooth and flush.
1. Fabricate and install railings to comply with requirements of ASTM E985 for structural performance based on testing performed in accordance with ASTM E894 and E935.
 2. Structural Performance: Handrails and top rails shall withstand the following structural loads:
 - a. Concentrated Load: 200 lbs., applied non-concurrently, in any direction.
 - b. Uniform Load: 50 lb/ft. applied simultaneously in both vertical and horizontal direction.
 - c. Concentrated loads and uniform loads need not be assumed to act concurrently.
 3. Shop fabricate to greatest extent possible.
 4. Interconnect railing members by butt-welding or by welding with internal connectors, unless otherwise indicated.
 5. At tee and cross intersections, notch ends of intersection members to fit contour of pipe and weld all around.
 6. Form changes in direction of railing members by radius bends, maintaining cylindrical cross-section of pipe throughout bend without buckling, twisting, cracking or otherwise deforming exposed surface of pipe.
 7. Provide galvanized inserts for concrete paving for attachment of rails, where occurs.

2.08 SOURCE QUALITY CONTROL AND TESTS

- A. Provide shop inspection and testing for welding in accordance with DSA IR, as required by CBC 2212A. Inspector shall submit Verified Reports conforming to DSA IR.

PART 3 EXECUTION

3.01 EXAMINATION

- A. Inspect adjacent construction. Ensure that conditions impairing execution are corrected. Commencement of work signifies acceptance of conditions.

3.02 PREPARATION

- A. Clean and strip primed steel items to bare metal where site welding is required.
- B. Supply setting templates to the appropriate entities for steel items required to be cast into concrete.

3.03 INSTALLATION

- A. Install in accordance with manufacturer's instructions.
- B. Install items plumb and level, measured from established lines and levels, accurately fitted, free from distortion or defects.
- C. Provide temporary bracing or anchors in formwork for items which are to be built into concrete or similar construction.
- D. Provide for erection loads, and for sufficient temporary bracing to maintain true alignment until completion of erection and installation of permanent attachments.
- E. Fastening to In-Place Construction: Provide anchorage devices and fasteners where necessary for securing metal items to in-place construction; including threaded fasteners for concrete inserts, toggle bolts, through-bolts, lag bolts, wood screws, and other connectors as required.
- F. Cutting and fitting:
 - 1. Perform cutting, drilling and fitting required for installation of miscellaneous metal items. Fit exposed connections accurately together to form tight hairline joints.
 - 2. Weld connections which are not to be left as exposed joints, but cannot be shop welded because of shipping size limitations.
 - 3. Do not weld, cut or abrade the surfaces of exterior units which have been hot dip galvanized after fabrication, and are intended for bolted or screwed field connections.
- G. Perform field welding in accordance with AWS D1.1.
- H. Obtain approval prior to site cutting or making adjustments not scheduled.
- I. Immediately after erection, clean and prime welds, abrasions, and surfaces not shop primed or galvanized, except surfaces to be in contact with concrete with the same materials used for shop finishing.
- J. Pipe railings: Plumb posts in each direction.
 - 1. Anchor posts in concrete by means of galvanized steel pipe sleeves, not less than 6" long, with an outside diameter not less than 1/2" greater than the outside diameter of the inserted pipe post. Provide steel plate closure secured to bottom of sleeve of width and length not less than 1" greater than outside diameter of sleeve. After posts have been inserted into sleeves, fill annular space between post and sleeve solid with non-shrink, non-ferrous grout.
 - 2. Anchor rail ends into masonry or concrete with steel round flanges welded to rail ends and anchored into wall construction with lead expansion shields and bolts.
 - 3. Secure handrails to walls using wall brackets, and wall return fittings at handrail ends. Provide brackets with not less than 3" projection from finish wall surface to center of pipe handrail, and with wall plate portion of bracket drilled to receive one 3/8" bolt. Locate brackets at not more than 5 ft. o.c. Provide flush-type wall return fittings with same projection as that specified for wall brackets.. Secure brackets and return fittings as follows:
 - a. Wood framing: Use lag screws.
- K. Metal Stairs Installation:
 - 1. Install the metal stairs and related items in strict accordance with reviewed shop drawings and the manufacturer's recommendations for installation, as applicable to project conditions and supporting substrates.
 - 2. All surfaces of stairs shall be cleaned of dirt, mud, and all other foreign matter.
 - 3. All erection marks, bare metal, and field connections shall be touched up with the same paint used for shop coat.
- L. Coordinate with installation of electrical and signal systems.

3.04 FABRICATION TOLERANCES

- A. Squareness: 1/4 inch maximum difference in diagonal measurements.
- B. Maximum Offset Between Faces: 1/16 inch.
- C. Maximum Misalignment of Adjacent Members: 1/16 inch.
- D. Maximum Bow: 1/8 inch in 120 inches.
- E. Maximum Deviation From Plane: 1/8 inch in 120 inches.

3.05 FIELD QUALITY CONTROL

- A. Field inspection and testing by Owner's Inspector and Testing Agency in accordance with Sections 01 4523.

3.06 DEMONSTRATION

- A. Demonstrate proper maintenance of bleachers to Owner's designated representative.

3.07 ADJUSTING

- A. Correct all damaged work by cleaning, repairing or replacing, and repainting, as acceptable to Architect.

3.08 CLEANING

- A. Clean-up: During progress of work, remove from site discarded materials and rubbish at end of each work day. No waste materials shall be placed in Owner's dumpsters. Removal of project wastes is sole responsibility of the Contractor.
- B. Clean completed work.
- C. Protect installed work from subsequent construction operations.
- D. Do not permit traffic over unprotected floor surface.

END OF SECTION

SECTION 13 4713

CATHODIC PROTECTION SYSTEM

PART 1 GENERAL

1.01 THIS SECTION INCLUDES

- A. The WORK of this Section includes providing corrosion control systems for the following structures as outlined in this Section and on the Drawings:
 - 1. A complete cathodic protection (CP) system for metallic fittings and appurtenances associated with the 8-inch diameter fire service pipeline
 - 2. A complete corrosion control system for the metallic fittings associated with the 2-inch non-metallic water pipeline beyond the water meter. The corrosion control system includes wrapping the fittings in petrolatum wax tape and then encasing in concrete with a minimum of 2-inches of cover.
- B. Electrical isolation of the structures from adjacent metallic structures, steel reinforced concrete structures, casings, structures of dissimilar metal or dissimilar coatings, conduits, and all other metallic components that may impact the operation of the CP system.
- C. Electrical bonding of all non-insulated, non-welded pipe joints and mechanical joints.
- D. Installation of galvanic anodes, test stations, other components associated with the CP system, and all other work described herein and on the Drawings.
- E. Testing of CP system during installation.
- F. Cleanup and restoration of work site.
- G. Final System Checkout: Testing of CP system after installation and backfill.

1.02 REQUIREMENTS

- A. If the products installed as part of this Section are found to be defective or damaged or if the WORK of this Section is not in conformance with these Specifications, then the products and WORK shall be corrected at the CONTRACTOR's expense.
- B. Any retesting required due to inadequate installation or defective materials shall be paid for by the CONTRACTOR at no additional cost to the owner.
- C. The WORK also requires that one Supplier or Subcontractor accept responsibility for the WORK, as indicated, but without altering or modifying the CONTRACTOR's responsibilities under the Contract Documents.
- D. The WORK also requires coordination of assembly, installation, and testing between the pipeline contractor and any CP material supplier or subcontractor.
- E. All electrical WORK shall be in accordance with NEC and local requirements.

1.03 RELATED SECTIONS

- A. The WORK of the following Sections applies to the WORK of this Section. Other Sections of the Specifications, not referenced below, shall also apply to the extent required for proper performance of this WORK.
1. Site Safety and Regulatory Requirements
 2. Excavation, Trenching, Backfilling, and Compacting
 3. Piping
 4. Cast-In-Place Concrete
 5. Protective Coatings

1.04 REFERENCED SPECIFICATIONS, CODES AND STANDARDS

- A. The WORK of this Section shall comply with the current editions of the codes and standards referenced in this specification, including the following:
1. AASHTO American Association of State Highway and Transportation Officials
 - a. H20 Specification for Highway Bridges
 2. ASTM ASTM International
 - a. A615 Standard Specification for Deformed and Plain Carbon-Steel Bars for Concrete Reinforcement
 - b. B3 Standard Specification for Soft or Annealed Copper Wire
 - c. B8 Standard Specification for Concentric-Lay-Stranded Copper Conductors, Hard, Medium-Hard, or Soft
 - d. B187 Standard Specification for Copper, Bus Bar, Rod, and Shapes and General Purpose Rod, Bar, and Shapes
 - e. B843 Standard Specification for Magnesium Alloy Anodes for Cathodic Protection
 - f. C94 Standard Specification for Ready-Mixed Concrete
 - g. D1248 Standard Specification for Polyethylene Plastics Extrusion Materials for Wire and Cable
 - h. G97 Standard Test Method for Laboratory Evaluation of Magnesium Sacrificial Anode Test Specimens for Underground Applications
 3. AWWA American Water Works Association

- a. C217 Petrolatum and Petroleum Wax Tape Coatings for the Exterior of Connections and Fittings for Steel Water Pipelines
- 4. NSF National Sanitation Foundation
 - a. NSF 61 Drinking Water System Components
- 5. NACE International, the Corrosion Society
 - a. RP0375 Field-Applied Underground Wax Coating Systems for Underground Pipelines: Application, Performance, and Quality Control
 - b. SP0169 Control of External Corrosion on Underground or Submerged Metallic Piping Systems
 - c. SP0286 Electrical Insulation of Cathodically Protected Pipelines
 - d. TM0497 Measurement Techniques Related to Criteria for Cathodic Protection on Underground or Submerged Metallic Piping Systems
- 6. NFPA National Fire Protection Association
 - a. NFPA 70 National Electric Code (NEC)
- 7. NEMA National Electrical Manufacturers Association
 - a. TC2 Electrical Polyvinyl Chloride (PVC) Tubing and Conduit
 - b. TC3 PVC Fittings for Use with Rigid PVC Conduit and Tubing
- 8. UL Underwriters Laboratories
 - a. 467 Grounding and Bonding Equipment

B. Whenever the Drawings or these Specifications require a higher degree of workmanship or better quality of material than indicated in the above codes and standards, these Drawings and Specifications shall prevail.

1.05 PERMITS AND JOB ACCESS

- A. Prior to the start of construction, the CONTRACTOR shall apply to the required authorities for permits required for installation of the CP system.
- B. The CONTRACTOR shall contact Underground Service Alert prior to commencing construction to locate existing utilities in the area of construction. Existing utilities include, but are not limited to, water lines, gas lines, telephone, street lights, sewer and storm drains and overhead and underground electric utilities.
- C. If traffic control is necessary, it shall satisfy the requirements of the governing locality.

1.06 QUALITY ASSURANCE

- A. Installation of the CP equipment shall be performed by individuals having at least five years of experience in the installation of the CP equipment described herein.
- B. All testing required to be performed by a "Corrosion Technician" shall be performed by a NACE certified Corrosion Technician under the supervision of a Corrosion Engineer. A Corrosion Technician is a NACE CP2 (CP Technician), CP3 (CP Technologist), or CP4 (CP Specialist). A Corrosion Engineer is a Registered Professional Corrosion Engineer or a NACE CP4 (CP Specialist).

1.07 SUBMITTALS

- A. The following shall be submitted to the ENGINEER prior to any equipment installation.
 - 1. Catalog cuts, bulletins, brochures, or data sheets for all materials specified herein.
 - 2. Statement that the equipment and materials proposed meet the Specifications and the intent of the Specifications.
 - 3. Statement of installation experience required.
 - 4. Schedule, including the expected start date and planned completion date.
- B. The following shall be submitted to the ENGINEER after completion of the WORK.
 - 1. Wire connection testing.
 - 2. Joint bond testing, before and after backfill.
 - 3. Final System Checkout Report.
 - 4. Record Drawings shall be submitted to and approved by the ENGINEER before the WORK is considered complete.

1.08 INTERFERENCE AND EXACT LOCATIONS

- A. The locations of CP equipment, test stations, devices, outlets, and appurtenances, as indicated are approximate only. Exact locations shall be determined by the CONTRACTOR in the field subject to the approval of the ENGINEER.
- B. The CONTRACTOR shall field verify all data and final locations of work done under other Sections of the Specifications required for placing of the electrical work.
- C. In case of interference with other work, foreign pipeline, or erroneous locations with respect to equipment or structures, the CONTRACTOR shall furnish all labor and materials necessary to complete the WORK in an acceptable manner to the OWNER. Deviations from the Drawings and Specifications shall be submitted to the OWNER for approval.

PART 2 PRODUCTS

2.01 GENERAL

- A. All materials installed must be new. All equipment and materials supplied shall be similar to that which has been in satisfactory service for at least 5 years.

2.02 GALVANIC ANODES

- A. Standard-potential magnesium anodes: Cast magnesium anodes shall conform to ASTM B843 Type AZ63B (commonly known as H1A). Anodes shall have an open circuit potential of 1.53 to 1.55 volts and current efficiency of 45 to 55% when tested in accordance with ASTM G97. Anodes shall have the following size, form, and shape. Anodes shall be manufactured by Farwest, Corpro, Mesa, Matcor, or equivalent.

| Ingot | | | | Packaged | | |
|----------------|-----------------|------------------|------------------|----------------|--------------------|------------------|
| Weight (lb) | Width (inch) | Height (inch) | Length (inch) | Weight (lb) | Diameter (inch) | Length (inch) |
| 32 | 5 to 6 | 5 to 6 | 20 to 21 | 68 to 70 | 8 to 9 | 28 to 30 |

- B. Galvanic anodes shall be pre-packaged in a cloth bag containing backfill of the following composition: 75% gypsum, 20% bentonite, and 5% sodium sulfate. The anodes shall be of the size indicated on the Drawings and placed where indicated on the Drawings.
- C. Anode lead wire:
 1. The wire attached to the anodes shall be of the size and type indicated on the Drawings. The anode lead wire shall conform to the specifications given for "Wires" in this specification.
 2. Connection of wire to the anode shall have a pulling strength that exceeds the wire's tensile strength.
 3. Anode lead wires shall be of one continuous length, without splices, unless otherwise indicated on the Drawings, from the anode connection to the test station.

2.03 READY-MIXED CONCRETE

- A. Ready-mixed concrete shall be in accordance with ASTM C94, permit requirements, and the Specification section for cast-in-place concrete.

2.04 REINFORCING STEEL

- A. Reinforcing steel shall be in accordance with ASTM A615, permit requirements, and the Specification section for reinforcing steel.

2.05 FLUSH-MOUNTED TEST STATION

- A. Flush-mounted test station boxes shall be traffic boxes rated to withstand AASHTO H20 traffic loading.
- B. The traffic boxes shall be G05 Utility Boxes, as manufactured by Christy Concrete Products, Inc.; No. 3RT Utility Box, as manufactured by Brooks Products; or an approved equivalent.
- C. Traffic box covers for test stations shall be cast iron with welded bead legend and labeled "CP TEST" or "ANODE," as required.

2.06 TERMINAL BOARDS

- A. Terminal boards shall be made of 1/4-inch thick phenolic plastic and sized as indicated on the Drawings.
- B. Connection hardware shall be brass or bronze. All connections shall be double nutted bolts with serrated lock washers.
- C. Copper bus bar shall be 1/8-inch thick and sized to fit. The copper bus bar shall be per ASTM B187 with 98% conductivity.

2.07 MECHANICAL LUGS

- A. Mechanical lugs shall be brass or copper with a brass, copper, or stainless-steel set screw. Tin plating on the lugs is optional. Aluminum lugs shall not be permitted. Zinc-plated steel set screws shall not be permitted. The lug shall be listed per UL 467, suitable for direct burial, and appropriately sized for the incoming wires. The lug shall be ILSCO Type XT-6DB, Burndy GKA8C, or an approved equivalent.

2.08 SHUNTS

- A. Shunts shall be the selected by the size indicated on the Drawings.
- B. 0.01-ohm, 6-amp shunts shall be manganin wire type, as indicated. Shunts shall be Type RS, as manufactured by Holloway, or equivalent.

2.09 CONDUIT AND FITTINGS

- A. The minimum conduit size shall be 1 inch unless otherwise indicated. Refer to NFPA 70 (NEC) for additional conduit size requirements.
- B. Conduit and fittings placed below grade shall be Schedule 80 PVC in accordance with NEMA TC2 and NEMA TC3.

2.10 CAUTION TAPE

- A. The caution tape shall be an inert plastic film designed for prolonged underground use. The caution tape shall be a minimum of 3 inches wide and a minimum of 4 mils thick.
- B. The caution tape shall be continuously printed over the entire length with the wording "CAUTION: CATHODIC PROTECTION CABLE BURIED BELOW."

- C. The wording shall be printed using bold black letters. The color of the tape shall be red.

2.11 WIRES

- A. Conductors shall consist of stranded copper of the gauge indicated on the Drawings. Wire sizes shall be based on American Wire Gauge (AWG). Copper wire shall be in conformance with ASTM B3 and ASTM B8.
- B. Insulation Type and Colors: As shown on the Drawings.
 - 1. High molecular weight polyethylene (HMWPE) wires shall be rated for 600 volts and shall conform to ASTM D1248, Type 1, Class C, Grade 5.

2.12 WIRE IDENTIFICATION TAGS

- A. Wire identification tags shall be the wrap-around type with a high resistance to oils, solvents, and mild acids. Wrap-around markers shall fully encircle the wire with imprinted alpha-numeric characters for pipe identification. The letters and numbers height shall be 3/16 inch at minimum.

2.13 EXOTHERMIC WELDS

- A. Exothermic welds shall be in accordance with the manufacturer's recommendations. Exothermic welds shall be Cadweld manufactured by Erico, Thermoweld manufactured by Burndy, or an approved equivalent.
- B. Prevent molten weld metal from leaking out of the mold, where necessary, by using Duxseal packing manufactured by Johns-Manville, Thermoweld packing material manufactured by Burndy, Cadweld T403 Mold Sealer manufactured by Erico, or an approved equivalent.
- C. The shape and charge of the exothermic weld shall be chosen based on the following parameters:
 - 1. Pipe material
 - 2. Pipe size
 - 3. Wire size and requirement for sleeves
 - 4. Number of wires to be welded
 - 5. Orientation of weld (vertical or horizontal)

2.14 EXOTHERMIC WELD COATING

- A. After exothermic welding, repair coatings and linings in accordance with the coating and lining manufacturer's recommendation.

- B. For bare steel, dielectrically coated steel, or ductile iron pipe, weld caps with integrated primer shall be used to cover the exothermic weld connecting the wire to the pipe. The weld cap shall be a 10-mil thick durable plastic sheet that has a dome filled with a moldable compound to assure complete encapsulation of the exothermic weld and a layer of elastomeric adhesive with integrated primer. The adhesive and primer shall be compatible with the pipe material and pipe coating material. Adhesion to steel shall be at least 10 lb/in per ASTM D1000. Weld cap with integrated primer shall be Handy Cap IP manufactured by Royston or equivalent for wire size up to 8 AWG and Handy Cap XL IP manufactured by Royston or equivalent for wire size up to 2 AWG.

2.15 PETROLATUM WAX TAPE

- A. Petrolatum wax tape shall meet or exceed the requirements of AWWA C217 and shall consist of three parts: Surface primer, wax tape, and outer covering. All three parts shall be the product of a single manufacturer.
- B. The primer shall be a blend of petrolatums, plasticizers, and corrosion inhibitors having a paste-like consistency. Primer shall be Wax-Tape Primer manufactured by Trenton, Denso Paste manufactured by Denso, or approved equivalent.
- C. The wax tape shall be synthetic-fiber felt, 45 to 90 mils thick, saturated with a blend of microcrystalline wax, petrolatums, plasticizers, and corrosion inhibitors that is capable of easy conformability over irregular surfaces. Wax tape shall be #1 Wax-Tape manufactured by Trenton, Denso Tape manufactured by Denso, or approved equivalent.
- D. The outer covering shall be a plastic wrap consisting of one 150-gauge sheet or three 50-gauge sheets wound together as a single sheet, clear polyvinylidene chloride, shrink wrap that is flexible enough to conform to irregular surfaces. Outer wrapping shall be Poly-Ply by Trenton, Poly-Wrap by Denso, or approved equivalent.

PART 3 EXECUTION

3.01 MATERIAL AND EQUIPMENT STORAGE

- A. All materials and equipment to be used in construction shall be stored in such a manner to be protected from detrimental effects from the elements. If warehouse storage cannot be provided, materials and equipment shall be stacked well above ground level and protected from the elements with plastic sheeting or another method, as appropriate.

3.02 EXCAVATION AND BACKFILL

- A. Buried wires shall have a minimum cover of 24 inches.
- B. Caution tape shall be installed above buried wire. Caution tape shall be installed a minimum of 6 inches above underground wires and conduits.
- C. Anode wire identification tags shall be placed on the wires prior to placing wire in conduit or backfilling.

3.03 SURFACE GROUND BED FOR GALVANIC ANODES

- A. Prepackaged anodes shall be installed at the locations indicated on the Drawings.
- B. Plastic or paper wrapping shall be removed from the anode prior to lowering the anode into the hole. Anodes shall not be suspended by the lead wires. Damage to the canvas bag, anode-to-wire connection, copper wire, or wire insulation before or during installation will require replacement of the entire anode assembly. Anodes shall be inspected and approved prior to backfilling.
- C. Anodes shall be backfilled with native soil. Backfilling with native soil shall proceed in 6-inch lifts, compacting the soil around the anode during each lift, until the backfill has reached grade. Upon completion of compaction of backfill to the top of the anode, and prior to filling the hole and compacting the backfill to the surface, a minimum of 10 gallons of fresh water shall be poured into the hole to saturate the prepackaged anode backfill and surrounding soil.
- D. Anode lead wires shall be routed and terminated on the panel board as shown in the Drawings.

3.04 TEST STATIONS

- A. Test stations shall be installed at the approximate locations shown on the Drawings. The CONTRACTOR shall field verify all final locations, subject to acceptance by the ENGINEER. Test stations shall be located within the pipeline easement. Test stations shall be located in areas not subject to vehicular traffic, such as sidewalks, unless otherwise approved by the ENGINEER.
- B. For flush-mounted test stations, place the bottom of the test box on native soil. Do not place rock, gravel, sand, or debris in the box. Install 4,000 psi concrete collar with reinforcement after placement of the test box to finished grade. Provide sufficient sloping in the concrete pad or surrounding pavement to provide drainage away from the test box.
- C. Connect wires to the terminal board as shown on the Drawings. Each wire shall be identified with a permanent wire identifier within 4 inches of the termination. After installation, all wire connections in the test station shall be tested by the Contractor to ensure they meet the requirements herein.
- D. For foreign pipeline test stations, the CONTRACTOR shall notify the owner of foreign utility piping for which foreign pipeline crossing test stations are to be installed. Notification shall be provided at least 2 weeks in advance. Test leads to foreign pipelines shall be installed in the presence and to the satisfaction of a representative of the foreign pipeline owner.
- E. The CONTRACTOR shall provide global positioning system (GPS) coordinates for each test station location with a minimum accuracy of 1 meter or 3 feet. The CONTRACTOR shall submit the GPS coordinates of the test stations to the ENGINEER after installation.

3.05 WIRES

- A. Buried wires shall be laid straight without kinks. Each wire run shall be continuous in length and free of joints or splices, unless otherwise indicated. Care shall be taken during installation to avoid punctures, cuts, or other damage to the wire insulation. Damage to insulation shall require replacement of the entire length of wire at the CONTRACTOR's expense.
- B. At least 12 inches of slack (coiled) shall be left for each wire at each flush-to-grade test station. Wire slack shall be sufficient to allow removal of wire extension for testing.
- C. Wire shall not be bent into a radius of less than eight times the overall wire diameter.
- D. The wire conduits must be of sufficient diameter to accommodate the wires. This shall be determined by the number and size of wires in accordance with the applicable codes and standards.
- E. Conduit shall be installed to a minimum depth of 24 inches below grade.
- F. Install caution tape above buried wire and conduits at a maximum depth of 12 inches below grade. Every 3 feet, double over the tape for a distance of 8 inches to increase the apparent flexibility of the tape.

3.06 WIRE IDENTIFICATION TAGS

- A. All wires shall be coded with wire identification tags within 4 inches of the wire end indicating diameter and type of pipe.
- B. Wire identification tags shall be placed on all wires prior to backfill and installation of test stations.

3.07 EXOTHERMIC WELD CONNECTIONS

- A. Exothermic weld connections shall be installed in the manner and at the locations indicated. Exothermic welds shall be spaced at least 6 inches apart from other exothermic welds, fittings, and circumferential welds.
- B. Coating materials shall be removed from the surface over an area of sufficient size to make the connection and as indicated on the Drawings. The surface shall be cleaned to bare metal per SSPC SP11 prior to welding the conductor. The use of resin impregnated grinding wheels will not be allowed.
- C. Only enough insulation shall be removed such that the copper conductor can be placed in the welding mold. If the wire conductor diameter is not the same as the opening in the mold, then a copper adapter sleeve shall be fitted over the conductor.

- D. The CONTRACTOR shall be responsible for testing all test lead and bond wire welds. The ENGINEER, at his or her discretion, shall witness these tests. After the weld has cooled, all slag shall be removed, and the metallurgical bond shall be tested for adherence by the CONTRACTOR. A 22-ounce hammer shall be used for adherence testing by striking a blow to the weld. Care shall be taken to avoid hitting the wires. All defective welds shall be removed and replaced in a new location at least 6 inches away from the original weld location.
- E. All exposed surfaces of the copper and steel shall be covered with insulating materials.
 - 1. For dielectrically coated pipes, a plastic weld cap with integrated primer shall cover the exothermic weld and surrounding area. All surfaces must be clean, dry, and free of oil, dirt, loose particles, and all other foreign materials prior to application of the weld cap.
- F. The CONTRACTOR shall inspect both the interior and exterior of the pipe to confirm that all coatings and linings removed or damaged as a result of the welding have been repaired. The CONTRACTOR shall furnish all materials, clean surfaces, and repair protective coatings and linings damaged as a result of the welding. Repair of any coating or lining damaged during welding shall be performed in accordance with coating or lining manufacturer's recommendations.
- G. After backfilling pipe, all test lead pairs shall be tested for broken welds using a standard ohmmeter. The resistance shall not exceed 150% of the theoretical wire resistance, as determined from published wire data.

3.08 JOINT BONDS

- A. Joint bonding shall be provided across flexible couplings and all non-welded joints to ensure electrical continuity, except where insulating joints have been installed to provide electrical isolation. Joint bonds shall be of the type, size, length, and number shown on the Drawings and installed as indicated.
- B. Bonding wires shall allow at least 2 inches of movement in the pipe joint. The wire shall be attached by exothermic welding. At least 2 bond wires shall be provided between all discontinuous joints.
- C. For ductile iron pipe, the CONTRACTOR may, at his or her own expense, provide weld plates that are installed by the pipe manufacturer at the spigot end of the pipe. Provision of the weld plates does not relieve the CONTRACTOR from responsibility for repair of damage to the coating or lining as a result of exothermic welding of the pipe. Coating repairs shall be performed in accordance with coating manufacturer's recommendations.

3.09 PETROLATUM WAX TAPE

- A. Petrolatum wax tape systems shall be applied on insulating joints and non-cathodically protected metallic appurtenances and fittings, regardless of whether they are bare or factory coated, as indicated in the Drawings. Extend the petrolatum wax tape coating system over any adjacent pipe coating by a minimum of two pipe diameters. Petrolatum wax tape systems shall be applied in accordance with NACE RP0375, AWWA C217, these Specifications, and the Manufacturer's recommendations.

- B. Surfaces shall be cleaned of all dirt, grease, oil and other foreign materials immediately prior to coating. Loose rust, loose paint and other foreign matter shall be removed in accordance with SSPC SP2 or SP3.
- C. A prime coating shall be applied in a uniform coating over the entire surface to be wrapped. A liberal coating shall be applied to threads, cavities, shoulders, pits, and other irregularities.
- D. Petrolatum wax tape shall be applied immediately after applying the primer using a 1-inch overlap. A spiral wrap shall be used, and slight tension shall be applied to ensure that there are no air pockets or voids. For bolts, nuts, and other irregular shapes, cut strips of wax tape and apply them by gloved hand so that there are no voids or spaces under the tape. Apply a sufficient amount of tape to completely encapsulate all exposed steel surfaces. After applying the tape, the applicator shall firmly press and smooth out all lap seams and crevice areas. The tape shall be in tight intimate contact with all surfaces. The minimum wax tape thickness shall be 70 mils over smooth surfaces and 140 mils over sharp and irregular surfaces, or more as required to fill all voids.
- E. Apply two layers of outer covering over the wax tape coating by tightly wrapping it around the pipe such that it adheres and conforms to the wax tape. Secure the outer covering to the pipe with adhesive tape.

3.10 WIRE CONNECTIONS

- A. After installation, all wire connections shall be tested to ensure electrical continuity at the test station locations by the CONTRACTOR to ensure that they meet the requirements and intent of the Contract Documents.

3.11 RESTORATION SERVICES

- A. Compaction of backfill for anodes and trenches shall match the existing conditions and shall be in conformance with the EARTH MOVING Section (31 20 00).
- B. RESTORATION OF SOD: Restore unpaved surfaces disturbed during the installation of anodes and wires to their original elevation and condition. Preserve sod and topsoil carefully and replace after the backfilling is completed. Replace sod that is damaged using sod of quality equal to that removed. Where the surface is disturbed in a newly seeded area, re-seed the area with the same quality and formula of seed as that used in the original seeding.
- C. RESTORATION OF PAVEMENT: Patch pavement, sidewalks, curbs, and gutters where existing surfaces are removed for construction in conformance with the ASPHALT PAVING Section (32 12 16) and the CAST-IN-PLACE CONCRETE Section (03 30 00).

3.12 FINAL SYSTEM CHECKOUT

- A. Upon completion of the installation, the CONTRACTOR shall provide testing of the completed system by a Corrosion Technician, and the data shall be reviewed by a Corrosion Engineer to ensure conformance with the Contract Documents, NACE SP0169, and NACE SP0286.
- B. The testing described herein shall be in addition to and not substitution for any required testing of individual items at the manufacturer's plant and during installation.

- C. Testing shall be performed at all test leads of all test stations, junction boxes, and locations of exposed pipe as soon as possible after installation of the CP system.
- D. Testing shall include the following and shall be conducted in accordance with NACE TM0497:
 - 1. Measure and record native pipe-to-soil and anode-to-soil potentials at all test locations. CONTRACTOR shall submit data to ENGINEER a minimum of 48 hours before energizing the cathodic protection system.
 - 2. Confirm electrical continuity of the cathodically protected pipeline or structure.
 - 3. Measure and record the "On" and "Instant Off" pipe-to-soil potentials at each location after the structure has been given adequate time to polarize.
 - 4. Measure and record the current output of each anode when the CP system is initially turned on and again after it has been given adequate time to polarize. 0286
- E. Test results shall be analyzed to determine compliance with NACE SP0169.
- F. The CONTRACTOR shall provide a written report, prepared by the Corrosion Engineer, documenting the results of the testing and recommending corrective work, as required to comply with the Contract Documents. Any deficiencies of systems tested shall be repaired and re-tested by the CONTRACTOR at no additional cost to the OWNER.

END OF SECTION

SECTION 21 00 00

FIRE PROTECTION GENERAL

PART 1 - GENERAL

1.1 GENERAL

- A. The General Conditions and Supplementary General Conditions are hereby a part of this Section as fully as if repeated herein.

1.2 SCOPE

- A. The work includes, but is not necessarily limited to, the furnishing of all labor, materials, equipment, and services necessary for, and reasonably incidental to, providing and installing complete fire protection systems, and other work as shown or indicated in the Fire Protection Drawings and Specifications.
- B. Consult all other Sections to determine the extent and character of this work specified elsewhere.
- C. Specifically refer to the following:
 - Section 21 05 00 Overhead Fire Protection Systems
 - Section 21 10 00 Underground Fire Service
- D. Make all connections to equipment requiring service from systems installed under this Section.

1.3 COORDINATION

- A. Before submitting a bid for the fire protection work the Contractor shall visit the site and become familiar with all the work on other related Drawings and Specifications, and plan the work to provide the best possible assembly of the combined work of all trades. No additional costs will be considered for work which has to be relocated due to conflicts with other trades.
- B. If, after examination of the bidding documents relating to the work, the Contractor has queries concerning the nature and scope of the work or intent of the Specifications, he/she shall promptly request clarification from the Architect. After contract award, claims of ignorance of the intent and scope of the contract shall not be allowed.
- C. Contractor is responsible for coordinating the schedule of inspections by Engineer at appropriate stages of construction such as rough-in, pre-final, and final, and at other times required by the Specifications or by the construction. Notify Architect and Engineer seven (7) days in advance of proposed site visit. Notification constitutes certification that construction is, or will be, complete and ready for inspection.
- D. Coordination Drawings: All work of this section must be coordinated to clear all work of other sections. Provide coordination drawings for all work of this section/division; see Division 01. For site utilities, see architectural drawings for additional coordination requirements.

1.4 SAFETY

- A. Contractors must conduct a weekly safety meeting with their employees and provide documentation as to attendance and topics of discussion. Engineer's construction support services do not constitute review or approval of Contractor's safety procedures. Contractor shall comply with all OSHA regulations. Contractor is required to obtain and pay for insurance required to cover all activities within Contractor's Scope of Work.

1.5 BUILDING LAWS

- A. Fire Protection work shall conform to all requirements prescribed by governmental bodies having jurisdiction and is to be in accordance with the California Building Code; all federal, state, and local codes and ordinances; all OSHA requirements; California Plumbing Code, California Mechanical Code, California Fire Code, and National Fire Protection Association; California State Code Title 8, Title 21, Title 24; and the Energy Conservation Standards.
- B. Should any part of the design fail to comply with such requirements, the discrepancy shall be called to the attention of the Architect prior to submitting bid.
- C. Should there be any direct conflict between the Drawings and/or Specifications and the above rules and regulations, the rules and regulations shall take precedence. However, when the indicated material, workmanship, arrangement, or construction is of a superior quality or capacity to that required by above rules and regulations, the Drawings and/or Specifications shall take precedence. Rulings and interpretations of enforcing agencies shall be considered as part of the regulations.
- D. After a Contract is awarded, if minor changes or additions are required by the aforementioned authorities, even though such work is not shown on Drawings or overtly covered in the Specifications, they must be included at the Contractor's expense.
- E. The Contractor is responsible to coordinate and make adjustments in his/her work with the full set of Contract Drawings and Specifications.
- F. All piping, and equipment shall be securely anchored to building structure as required herein and by the California Building Code and NFPA 13.

1.6 UNDERGROUND CONNECTIONS

- A. See Section 21 10 00 for Underground Fire Service connection requirements.

1.7 TEMPORARY CONSTRUCTION WATER

- A. The Contractor shall make all arrangements and provide necessary facilities for the temporary construction water from the Owner's source. Costs for the temporary construction water shall be paid for by Owner.

1.8 PAINTING

- A. See Section 09 for painting of piping, equipment, etc.

PART 2 - PRODUCTS

2.1 MATERIALS

- A. All materials used shall be new as listed in subheadings and indicated on Drawings. Inspect all materials and immediately remove defective materials from the site.
- B. All electrical materials shall bear the label of, or be listed by, the Underwriters' Laboratories (UL), unless the material is of a type for which label or listing service is not provided.
- C. Substitution:
 - 1. No substitute materials or equipment may be installed without the written approval of the Architect.
 - 2. Use of substitute materials or equipment may require changes in associated materials and equipment. Contractor shall submit detailed Shop Drawings and installation instructions of substitute materials and equipment to Architect for approval. Such submittals shall address all changes required in other items.
 - 3. All additional costs incurred by the substitution of material or equipment, or the installation thereof whether Architectural, Structural, Mechanical, Plumbing, or Electrical shall be borne by the Contractor who substitutes the materials or equipment in place of the items specified.
- D. Quality of Materials: Pipe fittings and equipment may be taken from stock but the Contractor will be required to submit manufacturer's certificates identifying the material and equipment furnished as conforming with these Specifications and such codes and standards as apply to the equipment specified. Any material on the site which cannot be identified by manufacturer's mark shall be removed from the site at Architect's request.

2.2 SUBMITTALS

- A. The review of submittals and approval thereof by the Architect does not relieve the Contractor from compliance with the requirements and intentions of the Drawings and Specifications to which the submittals pertain. The contractor acknowledges its responsibility to submit complete shop drawings and other required submittals. Incomplete submittals will be returned to the contractor unreviewed.
- B. Material List: An itemized list of material and equipment which the Contractor proposes to use shall be submitted to the Architect with number of copies indicated and within time indicated.
- C. Shop Drawings and Product Data:
 - 1. Submit all required Shop Drawings, product data, etc. at one time. Submittals shall be bound, tabbed, and properly indexed by Specification Section.
 - 2. Each item shall be identified by manufacturer, brand, and trade name; model number, size, rating, and whatever other data is necessary to properly identify and verify the materials and equipment. The words "AS SPECIFIED" will not be considered sufficient information.
 - 3. Each submittal shall bear the Contractor's stamp and mark indicating the Contractor has reviewed and approved the submittal.

4. Each submitted item shall refer to the Specification Section and paragraph in which the item is specified.
5. Accessories, controls, finish, etc. not required to be submitted or identified with the submitted equipment shall be furnished and installed as specified.
6. Submittals shall be all inclusive with all items requiring submittals being submitted at the same time; individual submittals will not be accepted.
7. Place orders for all equipment in time to prevent any delay in construction schedule or completion of project. If any materials or equipment are not ordered in time, additional charges made by equipment manufacturers to complete their equipment in time to meet construction schedule, together with any special handling charges, shall be borne by Contractor.

PART 3 - EXECUTION

3.1 DRAWINGS

- A. The Contract Drawings show the general arrangement and location of the piping and equipment. Work shall be installed in accordance with the Drawings, except for changes required by conflicts with the work of other trades. The Contractor shall provide for the support, expansion, and pitch of any rearranged piping in conformance with the intent of the Drawings, Specifications, and codes.
- B. Note that certain fire protection work is shown, wholly or in part, on Architectural Drawings.
- C. The contractor shall field verify existing conditions and provide accurate shop coordination drawings for coordination with other trades in accordance with Division 1.
- D. Fire Protection Drawings are diagrammatic and are intended to show the approximate location of equipment and piping. Dimensions shown on Drawings shall take precedence over scaled dimensions on Drawings. All dimensions shall be verified in the field by the Contractor.
- E. The exact location of apparatus, equipment, and piping shall be ascertained from the Architect or the Architect's representative in the field, and work shall be laid out accordingly. Should the Contractor fail to ascertain such locations the work shall be changed at Contractor's own expense when so ordered by the Architect. The Architect reserves the right to make minor changes in the location of piping and equipment up to the time of installation without additional cost.
- F. It is the intention of the Drawings and Specifications that, where certain items such as unions, expansion joints, and other mechanical components are not shown, but where such items are required by the nature of the work, shall be furnished and installed.
- G. The Fire Protection Drawings and Specifications are intended to supplement each other. Any material or labor called for in one shall be furnished even though not specifically mentioned in the other.
- H. Pipe sizes shown are the minimum allowable and shall be increased in size if required by code or wherever necessary to meet unusual conditions.

3.2 RECORD DRAWINGS

- A. Record Drawings shall be maintained at all times showing the exact location of piping mains, branches, valves, drains, etc. installed under all Sections. Obtain from the Architect, at cost, a complete set of prints. On these prints systematically and accurately keep a dimensional record of all work installed different from those shown on Drawings. Have these Drawings readily available for reference.
- B. Record Set: When above information is complete and acceptable to the Architect transfer this information accurately to reproducible tracings, purchased at cost from the Architect for this purpose, and deliver to the Architect for final review.
- C. Upon completion of the Architect's review of the Record Set the Contractor shall incorporate changes, as noted on the record set, including dimensions such as elevations, valves, etc. Deliver transparencies with one (1) set of prints to the Architect. Deliver one (1) complete set of prints to building Owner within ninety (90) days of issuance of final occupancy report.
- D. Inspector's Approval: Where a full-time inspector is employed by the Owner, the Record Drawing information shall be reviewed by the inspector during the course of construction and shall have the inspector's approval before submission to the Architect.

3.3 ACCEPTANCE TESTS

- A. Documentation on standard NFPA Acceptance forms and inspection documents shall be submitted to the Architect and DSA Inspector of Record.
- B. The required acceptance documents shall be signed by a licensed C-16 Contractor.

3.4 DAMAGE

- A. Repair any damage to the building, premises, and equipment occasioned by the work under this Section.
- B. Repair all damage to any part of the building or premises caused by leaks or breaks in pipe, or malfunctions of equipment furnished or installed under this Section until the warranty period expiration date.

3.5 COMPLETE WORKING INSTALLATION

- A. The Drawings and Specifications do not attempt to list every item that must be installed. When an item is necessary for the satisfactory operation of equipment, is required by the equipment manufacturer, or accepted as good practice, furnish without change in Contract cost.

3.6 STORAGE

- A. Provide proper protection and storage of all items and tools required for this work.

3.7 QUALITY OF WORK

- A. The quality of work shall be of a standard generally accepted in the respective trade. Use only experienced, competent, and properly equipped workers. Replace work falling below this standard as directed by the Architect.

- B. Systems shall be worked into a complete and integrated arrangement with like elements arranged to make a neat appearing and finished piece of work, with adequate head room and passageway free from obstructions. Such systems shall be installed by laborers experienced in the respective trades involved.

3.8 CONCRETE WALLS AND CONCRETE FOOTINGS

- A. Where pipes must pass through concrete walls and footings, they shall pass through Schedule 40 galvanized pipe sleeves set in place at time of construction. The sleeves shall provide clearance in accordance with NFPA 13
- B. Coordinate core drilled openings with Architect and General Contractor. Coordination shall include location, size, and spacing of openings. No slot openings will be allowed. Coordinate openings to avoid critical structural items such as reinforcing bars, tensioning tendons, etc.
- C. Also see Paragraph 3.15.

3.9 ELECTRICAL REQUIREMENTS - CONTROLS AND COORDINATION WITH ELECTRICAL CONTRACTOR

- A. The Fire Protection Contractor shall coordinate with the Electrical Contractor on furnishing and installing of controls, motors, starters, etc. Coordinate means informing Electrical Contractor of items requiring electrical connection, providing copies of submittal data, installation data, scheduling work to insure efficient progress, and promptly supplying those items to be installed by Electrical Contractor.
- B. The specific requirements for electrical power and/or devices for each and every piece of fire protection equipment requiring electrical service, supplied and/or installed under this Contract, shall be coordinated and verified with the Fire Protection Drawings, Fire Protection Sections of these Specifications, and with the manufacturers of the equipment supplied. This shall include the voltage, phase, and ampacity; conduit requirements; and exact location and type of disconnect, control, and/or connection required. Any changes from the Drawings and Specifications required as a result of this coordination shall be part of this Contract.
- C. Electrical Contractor shall furnish and install the following for all mechanical equipment:
 - 1. Conduit and wiring for line voltage power to the equipment.
 - 2. Disconnect switches.
 - 3. Manual motor starters.
 - 4. Magnetic motor starters when part of a motor control center. See Division 16 and Drawings for further information.
- D. The work under this Section shall include furnishing and installing all controls on low and manual line voltage, including thermostats, auxiliary switches, relay wiring, interlock wiring; equipment control panels and transformers; and controls conduit unless specifically indicated as part of other work. Materials and methods of the control installation shall be in accordance with the Electrical Specifications.
- E. The Fire Protection Contractor shall review all wiring connections which have any influence on this equipment or work and verify that these connections are correct before permitting any equipment to be operated which is furnished, installed, or modified under this Contract.

3.10 ELECTRICAL REQUIREMENTS - MOTORS AND EQUIPMENT FURNISHED UNDER THIS SECTION

- A. Motors and motor control equipment shall conform to the standards of the National Electrical Manufacturer's Association (NEMA). Motors and motor control equipment shall be as specified below. The work under this Section shall include:
1. Furnishing all motors, magnetic starters and automatic control devices for equipment furnished and installed by this Contractor. Electrical Contractor shall provide magnetic starters at motor control center where indicated.
 2. Installation of the above motors and control devices. Manual motor starters shall be furnished and installed by Electrical Contractor in accordance with Electrical Specifications.
 3. Furnishing and installing line and/or low voltage interlock wiring shall be by the Mechanical Contractor. Installation of wire includes the connection of devices. All work shall be in accordance with the materials and methods specified in the Electrical Specifications.
 4. Furnishing and installing completely wired equipment control panels with complete controls for automatic operation where indicated or when supplied with equipment.
 5. Furnishing and installing all control and interlock wiring from equipment control panels to related remote devices, fans, motors, heaters, and controls.
 6. Wire mounted on heat producing appliances shall be Type RHH or THHN (90°C).
 7. Except as noted above, disconnect switches, power circuits from electrical panelboard to disconnect switch, starters, and motors shall be furnished and installed under the Electrical Specifications.

3.11 ELECTRICAL EQUIPMENT ROOM PRECAUTIONS

- A. Piping shall not be installed in any switchgear room, transformer vault, telephone room or electric closet except as indicated. In any case, no piping shall be installed in the space equal to the width and depth of any electrical service equipment, switchboards, panel boards, or motor control centers and extending from the floor to a height of six feet above the equipment or to the structural ceiling, whichever is lower. Only sprinkler piping serving the room may be installed in those rooms.

3.12 CUTTING AND REPAIRING

- A. No cutting shall be done except with Architect's approval. Cutting of structural members or footings is prohibited without the prior written consent of the Structural Engineer.
- B. Where cutting of paving, walls, ceilings, etc. is necessary for the installation of the mechanical work, it shall be done under the direction of this Section. Damage caused by this cutting shall be repaired to match original and adjacent surfaces without additional expense to the Owner. Cutting of new construction shall be by the installing Contractor of that construction as directed by this Contractor.

3.13 PIPE AND VALVE IDENTIFICATION

- A. Identify all piping contents with letter legend on color background identifying hazard or use of material.

- B. The pipe marker system shall conform completely with "The Scheme for Identification of Piping Systems" (ANSI A13.1). More specifically, the pipe marker must possess the following:
1. ANSI specified color coded background.
 2. ANSI specified color of legend in relation to background color.
 3. ANSI specified legend letter size.
 4. ANSI specified length of color field (marker length).
- C. The following tables will serve to clarify the above mentioned requirements:

TABLE 1

| Outside Diameter of Pipe or Covering | Length of Color Field | Size of Letters |
|--------------------------------------|-----------------------|-----------------|
| 3/4" to 1 1/4" | 8" | 1/2" |
| 1 1/2" to 2" | 8" | 3/4" |
| 2 1/2" to 6" | 12" | 1 1/4" |
| 8" to 10" | 24" | 2 1/2" |
| Over 10" | 32" | 3 1/2" |

- D. All pipes 3/4" I.D. and smaller shall be marked with 1 1/2" brass tags equivalent to valve tags.
- E. Provide flow markers consisting of labels similar to pipe markers with a large black arrow printed on same background color to indicate direction of flow.
- F. Place pipe marker and flow marker on each pipe on both sides of walls or floors through which pipes pass. Place markers adjacent to valves and fittings or branch take-off and for exposed piping locate markers to be clearly visible to person standing on floor, and at not over 30'-0" intervals on all straight runs of pipe.
- G. All valves under 3/4" I.D.: 18 gauge brass identification tags 1 1/2" in diameter with depressed 1/2" high black filled letters above 1/2" black filled numbers. Tags shall be fastened securely at specified locations. Valve tags shall show valve number, purpose, and normal condition (open or closed).
- H. Tag Locations:
1. Adjacent to each valve and fitting except on plumbing fixtures and equipment.
 2. At each branch and riser take-off.
 3. At each pipe passage through wall, floor, and ceiling construction.
 4. At each pipe passage to underground.
 5. On all horizontal pipe runs, marked every 25'-0".

3.14 VALVE TAGS AND CHART

- A. Furnish and install in each mechanical room a single typed valve chart identifying all valves with their respective tag numbers, size, manufacturer, model number, service, and indicating whether each valve is normally open or normally closed. Chart shall be mounted in a neat sheetmetal frame with glass front. The frame shall be arranged so that valve chart is removable. Provide three (3) additional copies of valve chart in maintenance manuals.

3.15 SLEEVES AND SEALING

- A. Provide sleeves for all pipes passing through new floors, walls, partitions, and any other building construction, of adequate diameter to allow minimum clearance all around between sleeve and pipe as required by NFPA 13.
- B. Lay out work prior to concrete forming. Reinforce sleeves to prevent collapse during forming and curing.
- C. All floor sleeves required shall extend 1" above finished floor except through mechanical equipment room floors and shafts where sleeves shall extend 2" above finished floor level. Sleeves through roof shall extend 8" above roof. Wall sleeves shall be flush with face of wall unless otherwise indicated. Waste stacks using carriers shall have sleeves flush with floor and sealed.
- D. Sleeves shall permit free thermal expansion of pipe without binding or contact with structure.
- E. Do not support pipes by resting pipe clamps on floor sleeves. Supplementary members shall be provided so pipes are floor supported.
- F. Special sleeves detailed on Drawings shall take precedence over this Section.
- G. Pipe sleeves as scheduled below unless otherwise indicated:
 - 1. Plaster or Drywall:
Schedule 40 galvanized steel pipe.
 - 2. Concrete or Masonry Walls and Concrete Bases:
See Paragraph 3.8.
 - 3. Waterproof membraned floors, walls, concrete pits, foundation walls, etc. as detailed or specified in other Sections.

3.16 SUPPORTS

- A. All supports and bracing shall comply with NFPA 13.
- B. All equipment and piping shall be mounted on, or suspended from, foundations and supports as specified and indicated, and seismically braced to structure.
- C. Seismic restraints shall be provided in accordance with NFPA 13.
- D. All piping and equipment shall be securely anchored to building structure as required by the Specifications, California Title 24, the California Building Code, and NFPA 13.

- E. Earthquake restraints shall be capable of resisting the gravity lateral loads required by NFPA 13.
- F. Supplemental Supports: Provide supplemental supports to span building structural elements as necessary for equipment foundations and supports. Provide Shop Drawings to Mechanical and Structural Engineers for approval prior to installation.

3.17 ACCESSIBILITY

- A. General: Valves, pressure gauges, and indicating equipment or specialties requiring reading, adjusting, inspection, repairing, removal, or replacement shall be conveniently and accessibly located with reference to finished building. Gauges shall be installed to be easily read from floor.
- B. Panels: No unions, flanges, valves, controls, or equipment shall be placed in a location that will be inaccessible after the system is complete. Access panels or doors shall be provided where required whether or not shown on Drawings.
- C. Access Panels in Walls or Ceilings:
 - 1. Provide access panels in walls or ceilings where indicated and where required to provide access to valves, dampers, and other appurtenances. Panels shall be style as selected by Architect and as directed by wall or ceiling construction. Panel size shall be 24" x 24" unless indicated otherwise. Panels in acoustical barriers shall have same transmission loss as barrier. Panels in rated construction shall have same rating as construction in which installed.
 - 2. Door panels shall be no lighter than 14 gauge steel. Doors shall be equipped with concealed spring hinges and flush, screwdriver operated locks, except that key operated locks shall be used for all access doors in walls where door is within 6'-0" of floor. Locks for all key operated doors shall be keyed alike.
 - 3. Doors in ceramic tile surfaces shall be stainless steel or chrome plated. Doors in other finished surfaces shall be prime coated.
- D. Equipment Spaces: Provide aisles between equipment and piping, electrical gear, etc. for complete service and inspection of equipment. Maintain minimum 6'-6" headroom in all access aisles. Maintain minimum 36" clearance at all service panels. Provide minimum clearances at electrical equipment per NEC. Provide 36" wide, 3/4" thick plywood covered catwalks in attics from access door to equipment.

3.18 TESTING

- A. Test all piping, equipment, and systems as called for in the Specifications. Notify Architect and inspection authorities prior to testing so that they may be witnessed. Protect all personnel and equipment during testing. Where Specifications do not cover specific points or methods, conform to manufacturer's specifications.

3.19 EQUIPMENT

- A. All equipment shall be accurately set and leveled. Supports shall be neatly placed and properly fastened. All equipment shall be fastened in place with bolts.
- B. Keep all openings closed with plugs or caps to prevent entrance of foreign matter. Protect all piping, ductwork, fixtures, and equipment against dirt, water, chemical, or mechanical

damage both before and after installation. Any equipment or apparatus damaged prior to final acceptance shall be restored to original condition or replaced at the Architect's discretion and at no additional cost to the Owner.

- C. Start-Up: Equipment shall be adjusted, lubricated, aligned, etc. prior to start-up. Inspect each piece of equipment prior to start-up. Start each piece of equipment in accordance with manufacturer's directions and warranty requirements.
- D. Finish: Protect all equipment and materials until in use. Any visible rust or corrosion shall be removed as directed prior to installation. All damaged factory painted finishes shall be cleaned and painted with manufacturer provided paint.

3.20 MANUFACTURER'S DIRECTIONS

- A. Materials and equipment shall be installed in accordance with manufacturer's application and recommendations, requirements, and instructions, and in accordance with Contract Documents. Where manufacturer's instructions differ from those indicated or specified, they shall be brought to Architect's attention for resolution prior to equipment ordering and installation.
- B. Where requirements indicated in Contract Documents exceed manufacturer's requirements, Contract Documents shall govern.

3.21 FURRING AND PIPE SPACES

- A. Spaces provided in the design of the building shall be utilized and the work shall be kept within the furring lines established on the Drawings.
- B. Layout: Maintain maximum head room under piping and equipment. Contractor to coordinate line locations with beams, windows, etc. to provide maximum clearance. From Drawings, ascertain heights of suspended ceilings and size of pipe shafts in which piping is concealed, and location and size of structural members in and adjacent to pipe shafts. Coordinate piping installation with ductwork, lighting, and other equipment. Ensure necessary clearances on trim plates at exposed penetrations of walls and floors. If sufficient room is not available above suspended ceiling or vertical shafts obtain clarification from Architect before work is started.

3.22 SEISMIC RESTRAINTS

- A. General: All work, materials and methods used shall conform to the Drawings and Specifications. NFPA 13 Guidelines shall be followed when specific details are not shown on the Drawings. Anchorage of equipment for which specific details are not shown on the Drawings shall be adequate to resist the forces based on the required "CP" factor. Such anchorage shall be approved by the Architect, Structural Engineer, and DSA
- B. All supports shall be in accordance with NFPA 13 and 2010 CBC.
- C. Piping:
 - 1. Pipe bracing system shall conform to the Drawings and to Specification requirements hereinafter listed, or shall be a pre-approved manufacturer's system such as Tolco Seismic Bracing System, or approved equal.

2. The Contractor shall submit Shop Drawings indicating the location of all seismic braces and provide a legend giving load information and model specifications prior to installation. Such prearranged system shall conform to requirements of the Specifications.
3. Brace all pipes with 2 1/2" I.D. and larger in accordance with NFPA 13.
4. Transverse bracings at 40'-0" on center maximum (minimum of one brace per direction of run).
5. Longitudinal bracings at 80'-0" on center maximum (minimum of one brace per direction of run).
6. Transverse bracing for one pipe section may also act as longitudinal bracing for the pipe section connected perpendicular to it, if the bracing is installed within 24" of the elbow or tee and is connected to the largest pipe.
7. Do not use branch lines to brace main lines.
8. Provide flexibility in joints where pipes pass through building seismic or expansion joints or where rigidly supported pipes connect to equipment with vibration isolators.
9. At vertical pipe risers, support the weight of the riser at a point or points above the center of gravity of the riser wherever possible. Provide lateral guides at the top and bottom of the riser and at intermediate points not to exceed 30'-0" on center.
10. Provide large enough pipe sleeves through walls or floors to allow for anticipated differential movements.
11. Do not fasten one rigid piping system to two dissimilar parts of the building that may respond in a different mode during an earthquake (e.g., a wall and a roof).
12. Cast iron piping systems are included in these requirements.
13. All trapeze hangers shall be braced.

3.23 CLEAN-UP

- A. During the course of work under this Section, all rubbish, debris, surplus materials, tools, etc. resulting from this work shall be removed from work area and shall be disposed of off-site at the end of each working day. The Owner's premises shall be left clean and in a condition acceptable to the Architect.
- B. Clean all work installed under this Contract to satisfaction of Owner and submit documentation that each system has been cleaned and results witnessed by the Architect's representative.

3.24 ENGRAVED NAMEPLATES

- A. Furnish and install plastic laminated engraved nameplates in accordance with NFPA 13, the local Fire Marshal and DSA.

3.25 FINAL INSPECTION

- A. The Contractor shall furnish the Architect with certificates of final inspection and approval from the inspection authorities having jurisdiction.

3.26 GUARANTEE

- A. The Contractor shall guarantee the quality of all work and the quality of equipment and materials in accordance with the provisions of the General Conditions and Special

Conditions. Should any defects occur during this period, the Contractor shall promptly repair or replace defective items as directed by the Architect, without cost to the Owner.

3.27 SITE VISITS BY ENGINEER

- A. Engineer's responsibility is limited to normal construction support services only, consisting of office consultation, site visits, and reports to the Architect at appropriate stages of construction such as rough-in, pre-final, and final. All costs incurred by the Engineer for additional site visits or office work required to complete the project as the result of incomplete coordination or supervision by the Contractor or the Mechanical Sub-Contractor shall be paid for by the Contractor.

3.28 OPERATING AND MAINTENANCE MANUALS

- A. Complete sets of bound instructions containing the manufacturer's operating and maintenance instructions in accordance with specification section 21 05 00 Overhead Fire Protection System:
- B. Field Instructions: Upon completion of the work and at a time designated by the Owner the services of one or more competent Engineers shall be provided by the Contractor to instruct a representative of the Owner in the operation and maintenance of the systems. These field instructions shall cover all the items contained in the bound instructions and shall be of a sufficient length and detailed nature, in the Engineer's judgment, to insure safe and efficient operation.

**** END OF SECTION ****

SECTION 21 05 00

OVERHEAD FIRE PROTECTION SYSTEM

PART 1 - GENERAL

1.1 GENERAL

- A. The General Conditions, any Supplementary Conditions, Section 21 00 00, Fire Protection General, and Division 1 are hereby a part of this Section as fully as if repeated herein.

1.2 SCOPE

- A. Furnish all labor, materials, equipment and services required for and/or reasonably incidental to the completion of the complete hydraulic calculated sprinkler system per NFPA 13 and other governing agencies.

1.3 WORK INCLUDED IN THIS SECTION

- A. Furnish all labor, materials, equipment and services required for and/or reasonably incidental to the completion of the following work:
1. Sprinkler riser sized by hydraulic calculation complete with as detailed on the drawings.
 2. Complete hydraulic wet-pipe automatic fire sprinkler system through all portions of the Fitness Building. The fitness area is calculated for Light Hazard, plus 100 GPM total combined hose flow as shown on the drawings. The storage areas are calculated for Ordinary Hazard Group 1, plus 250 GPM total combined hose flow as shown on the drawings.
 3. Sprinkler heads and piping are required at all areas shown on Architectural and/or Structural Drawings.
 4. Furnish and install alarm bell flow switch riser. See Drawing for location of riser. Alarm bell shall be located a minimum of 7'-0" above the ground.
 5. Prime and finish painting of portions of the fire protection system as required by the DSA, Architect or Rating Agency. See also Division 09, Painting.
 6. Conformance to all design requirements of the local Fire Marshal and the Rating Agency. Preparation of all required Shop Drawings and details for the approval and installation of the system.
 7. Coordination of installation of electrical conduit for supervisory systems. Provide all contacts required.
 8. Arranging for all required inspections by the local official and by the Rating Agency. Cost of all testing and of special inspections required by them.

1.4 RELATED WORK UNDER OTHER SECTIONS

- A. The following work is not in the work under this Section, but is covered in other Sections.
1. Installation and connection of the electrical conduit for supervisory systems as shown on the Electrical drawings.
 2. Installation of the fire alarm systems as shown on the Electrical drawings.
 3. Installation of the underground fire service.

1.5 CODE REQUIREMENTS

- A. All work shall conform to the requirements of the applicable Federal, State and local building and safety codes, ordinances and regulations.
- B. Special attention shall be given to local fire regulations and the regulations of the local fire department and building department.
- C. Special attention shall be given to local rulings of the Rating Agency.
- D. Nothing in this Specification or on the Drawings shall be construed as permitting a departure from any applicable Federal, State or local building and safety code, ordinance or regulation, or from any requirements of the local fire department, building department and/or Rating Agency.

1.6 RATING AGENCY

- A. Whenever the words "Rating Agency" are used in this Specification, they shall mean the insurance underwriters.

1.7 SUB-CONTRACTOR QUALIFICATIONS

- A. This Contractor must be a C-16 Contractor, licensed by the State of California Contractor's Licensing Board. No portion of the fire protection system (performed on the job site) shall be subcontracted.
- B. All fire sprinkler installers shall be certified and registered in accordance with the Automatic Fire Extinguishing Systems Certification requirements of CCR, Title 19, Division 1, Chapter 5.5.

1.8 SUBMITTALS

- A. Submit for review, within fifteen (15) days after signing contract, the required number of copies of a complete list of materials proposed for use, including sizes, capacities, etc. See Division 1 for requirements. This list includes:
 - 1. Sprinklers.
 - 2. Piping.
 - 3. Fittings.
 - 4. Hangers and Bracing.
 - 5. Pressure Gauges.
 - 6. Sprinkler Head Cabinet.
 - 7. Valves.
 - 8. Check Valves.
 - 9. Flow Switch.
- B. Shop Coordination Drawings shall show all details and information required by NFPA 13, NFPA 14 and/or NFPA 24. In addition, all earthquake bracing (longitudinal and lateral) shall be shown. If unnecessary deviation from Drawings are made by Contractor which cause

- additional cost to the Owner, Contractor shall submit the changes to the Architect for compliance verification and the additional cost shall be borne by the Contractor
- C. Final Record Drawings shall be submitted in accordance with Paragraph A above and paragraph Record Drawings of this Section, showing exact dimensional locations of all underground piping and of all risers, mains and cross-mains
 - D. On completion of the job, furnish the Architect with a copy of the "Contractor's Material and Test Certificate" (Part A and/or B), signed by the local Fire Marshal, and a copy of the Transmittal Letter sending the certificate to the Rating Agency and DSA.

1.9 DESIGN OF SYSTEM

- A. The riser locations are shown on the Drawings. Any request for changes must be submitted to the Architect 48 hours prior to bid times for consideration.
- B. All work shall be designed in accordance with the requirements of DSA, the Rating Agency, the latest editions of NFPA 13, 14, and 24 and the appropriate edition of the California Building Code and the California Fire Code (as modified by local ordinance or ruling).
- C. Each building's sprinkler system shall be hydraulically calculated for the hazards or commodity indicated in Section 1.4.
- D. Calculations shall be based upon the water supply available at the connection with the City water main.
- E. Calculations shall demonstrate the system has a design cushion of at least ten percent of the available static pressure, or as required by local authority if greater.
- F. The Sprinkler Contractor shall refer to the Architectural, Structural, Mechanical, and Electrical Drawings and coordinate the system layout to not interfere with the arrangement of lighting fixtures, grilles, diffusers, ductwork, equipment and piping in the Building.
- G. All piping shall be installed for routing as shown on Drawings, including cross-mains, if shown. Also, piping shall be installed as close as practical to the roof structure so as to provide the maximum possible clear height. Cross-mains shall follow the roof line (tight to the bottom of the beams, purlins or joints) so as to remain at an approximately constant distance from the roof throughout.
- H. Fire protection system lines shall be designed so as to avoid all other utility lines, conduit and structural components shown on the Drawings. Fire protection system lines must give way to all gravity lines. Notify Architect if conflicts cannot be coordinated in the field.
- I. Cutting structural members shall not be allowed, unless otherwise approved by the Structural Engineer or the Architect.

PART 2 - PRODUCTS

2.1 MATERIALS

- A. All materials shall be new and currently listed in the Underwriters' Laboratories, Inc. Fire Protection Equipment List and shall be acceptable to DSA. Material that is pending approval shall not be acceptable.
- B. Underground piping shall be installed in strict accordance with the manufacturer's installation guide.
- C. Cast or ductile iron shall be installed to within 5'-0" of building and under all footings and slabs.
- D. Above ground piping to be ANSI/ASTM A135 electric resistance welded and seamless carbon steel pipe. 1 1/2 in. and smaller use Schedule 40 with threaded fittings, 2" and greater shall be welded or roll grooved, minimum wall thickness for 300 psi in accordance with Schedule 10 up to 5 in., 0.134 in. wall for 6 in. pipe, and 0.188 in. wall for 8 in. and 10 in. pipe.
- E. Backfill shall be accomplished in strict accordance with the manufacturer's installation guide and the "Backfill" Section of these Specifications.
- F. Overhead piping, fittings and hanger material shall conform to the requirements outlined in NFPA 13.
- G. Chrome plated escutcheon plates shall be provided where sprinkler piping passes through walls, floors or ceilings.
- H. The escutcheons shall be the same size throughout the building and shall match ceiling decor.
- I. A metal box containing replacement sprinkler heads shall be mounted near the riser inside the building and shall contain at least 6 heads and at least 2 of each type of head installed in the building. Also included shall be one wrench for each type of head used in the building.
- J. Bushings shall not be used unless specifically approved by the Architect.
- K. Provide and install head guards on sprinkler heads in areas where they could be damaged (stairwells, mechanical rooms, electrical rooms, emergency generator rooms, etc.).
- L. Water flow switches shall be furnished and installed where indicated on the Drawings. Flow switch shall be UL rated by Notifier or approved equal. Flow switches shall be CSFM approved. Each switch shall have minimum of two poles for 120 V operation.
- M. Tamper-proof switches shall be 120 V tamper switches for each isolation and control valve in each area. Electrical wiring and annunciating. Tamper switches shall be CSFM approved.
- N. Remote inspector's Test station to be per NFPA 13, at location shown on Drawings. Test station to be provided with isolation valve and orifice equal to one sprinkler head flow, with drain to sanitary sewer.

2.2 HANGERS, INSERTS, AND SUPPORT

- A. General: Provide hangers, brackets, supports, anchors and related appurtenances as required to support all piping and equipment provided under this Section. Piping and equipment supports shall conform to DSA approved drawings.
- B. Piping supports shall conform to hanger details on DSA approved drawings and NFPA 13.
- C. Manufacturers: Tolco or approved equal.
- D. Floor Supports: Provide, where required, necessary floor supports for piping and equipment. Supports shall be fabricated from structural members or shall be masonry piers.
- E. Sway Bracing: Per NFPA 13, DSA approved drawings and details.

2.3 SPRINKLER VALVES

- A. Manufacturer: Selection based on Stockham, Stockham, Kennedy, Walworth or Lunkenheimer, only, unless otherwise noted. All valves must be submitted and meet rating as scheduled below. No foreign manufactured valves shall be used.
- B. Valve pressure not less than 175 PSIG, except drain valves.
- C. Main Drain Valves: 2" Nibco T-301-W, bronze body and trip, UL
- D. Riser Check Valve: Tyco CV-1 riser swing check valve.
- E. Riser Control Valve: Tyco BFV-N indicating butterfly valve with two sets of factory spot (single pole double throw) switches.
- F. Inspectors Test Valve: tyco 1 1/4" model F350 test and drain valve with 5.6K test orifice, shut-off valve and visual flow indicator.
- G. Gauges: 3 1/2", 0-300psi, Ashcroft type 1005P, XUL fire protection sprinkler service -gauge fitted with gauge valve shut-off, UL, FM approved.

2.4 HOSE VALVES

- A. Hose Valve: FPPI Angled Hose Valve, 300 psi rated, 2 1/2" FNPT Inlet X 2 1/2" MNST hose thread outlet, with brass chain and cap or approved equal.

2.5 SPRINKLER HEADS

- A. Exposed Ceiling Construction:
 - 1. Quick Response: Exposed upright automatic glass bulb type, plain brass finish, equal to Tyco, TY-FRB.
 - 2. Standard Response: Exposed upright automatic glass bulb type, plain brass finish, equal to Tyco, TY-B.
- B. Finished Ceiling: Contractor to check with Architect on color to have manufacturer paint cover plates.

1. Concealed: Concealed pendent automatic glass bulb type, equal to Tyco, "Royal Flush II".
 2. Recessed: Recessed pendent automatic glass bulb type, equal to Tyco, TY-FRB.
 3. Hard Ceiling: Pendent automatic glass bulb type equal to Tyco, TY-FRB with Tyco 401 style escutcheon.
 4. Cooler/Freezer: Dry pendent, quick response, standard coverage, equal to Tyco, DS-1.
- C. Sidewall Heads: Contractor to check with Architect on color to have manufacturer paint cover plates.
1. Recessed horizontal sidewall automatic glass bulb type equal to Tyco, TY-FRB.
- D. Special Heads, Combustible Concealed Space: Upright automatic glass bulb type, plain brass finish, equal to Tyco, CC3.
- E. All heads, except as noted, to have temperature rating at 200°F. Set head at and around heating devices suitable under normal operation to eliminate false alarm by generated heat.
- F. Submittal: Submit 2 of each type of sprinkler head, complete with canopy, for Architect's review prior to ordering heads.

2.6 ALARM RELATED COMPONENTS

- A. Electric Bell: Potter 10" PBA1210, UL, FM approved CSFM listed, or approved equal.
- B. Riser Flow Switch: Potter VSR vane type waterflow alarm switch with retard, UL, FM approved, CSFM listed, with (2) single pole adjustable switches.
- C. Shunt Trip Flow Switch: Potter VS-SP vane type waterflow alarm switch without retard, UL, FM approved, CSFM listed, with (2) single pole switches.

2.7 ACCESSORIES

- A. Sprinkler Cabinet: Tyco 12 head cabinet part number P/N 1124.
- B. Access Panel: 24" x 24" Croker FRPWB1865 fire rated access panel with 16 gauge steel door, continuous hinge and dry wall bead frame.

2.8 PRESSURE GAUGE

- A. 3 1/2" 0-300psi Ashcroft type 1005P, XUL fire protection sprinkler service gauge fitted with gauge valve shut-off, UL, FM approved.

2.9 SEISMIC JOINT

- A. Seismic Joint: Metraflex fireloop seismic loop joint MLUG80XX series sized as shown on the plans. Seismic joint shall allow for a minimum of +/- 4" of seismic movement.

2.10 EXPANSION PLATE

- A. Viking 12620 expansion plate to conceal 1" annular clearance around pendent head recessed escutcheons in suspended lay in ceilings.

PART 3 - EXECUTION

3.1 GENERAL REQUIREMENTS

- A. Prior to bid, visit the job site and familiarize with local conditions, including verification of the location of the existing utilities.
- B. The contractor shall field verify existing conditions and provide accurate shop coordination drawings for coordination with other trades in accordance with Division 1.
- C. All piping shall be installed in a manner acceptable to DSA.
- D. All piping shall be pressure tested and flushed according to the procedures set forth in NFPA 13, NFPA 14, and NFPA 24, and witnessed by the General Contractor, and the DSA Inspector of Record.
- E. All equipment installed under this Contract shall be properly thrust blocked and earthquake braced. This Contractor shall be responsible for the proper design and installation of the equipment and for satisfying DSA, CSFM and the Architect that these requirements have been met. Drawings shall show locations of earthquake bracing, both lateral and longitudinal.
- F. All equipment installed under this Contract shall be protected from external damage. This Contractor shall be responsible for the proper design and installation of the equipment, and for satisfying DSA, CFSM and the Architect that these requirements have been met. Shop Drawings shall show details of protective equipment.
- G. The Contractor shall furnish and install all sleeves required for his/her work where it passes through concrete. If sleeves are not installed, all penetrations shall be core drilled. All penetrations shall be approved by the Architect before drilling.
- H. This Contractor shall be responsible for any damage to other work caused by this installation or by leaks in the fire protection lines.
- I. This Contractor shall be responsible for coordinating his/her work with the General, Electrical, Mechanical, and Plumbing Contractors, and with other trades.
- J. All work shall be done in a neat and workmanlike manner. All heads to be located as shown in the fire protection ceiling plans, on center or quarter points of ceiling tiles unless otherwise noted. Location of sprinkler heads shall take note of obstructions.
- K. Escutcheons shall not be permitted closer than 6" to T-bar ceiling members if conflicts with lights or grilles do not permit the centering of the heads in the tiles. Architect shall have final approval on exact location of sprinkler heads. Escutcheons shall not be mounted closer than 6" to any other ceiling mounted device.

3.2 TOOLS

- A. All special tools for proper operation and maintenance of the equipment provided under this Section shall be delivered to the Owner's representative and a receipt requested for same.

3.3 IDENTIFICATION

- A. Valves:
 - 1. Riser control valve and floor control valves shall be clearly identified in the Riser Room.

- B. Piping Identification:
 - 1. Apply color coded polyvinyl chloride pipe bands identifying service per Section 21 00 00.
 - 2. On exposed piping, apply bands at 20'-0" on centers at straight runs, at valve locations, and at points where piping enters and leaves a partition, wall, floor, or ceiling.
 - 3. On concealed piping installed above removable ceiling construction, apply bands in manner described for exposed piping.
 - 4. On concealed piping installed above non-removable ceiling construction, or in pipe shafts, apply bands at valves or other devices that are made accessible by means of access doors or panels.
 - 5. Apply bands at exit and entrance points at each piece of equipment.
 - 6. Band widths shall be 8" for pipes up to 10" diameter, and 16" for larger diameter piping. Letter heights stating service shall be pre-printed on band, 3/4" high for 8" bands and 1 1/4" high for 16" bands.
 - 7. Colors shall conform to ASA Standard A13.1.
 - 8. Tags and bands shall be approved for this service
 - 9. Where flexible sprinkler hose fittings are installed and supported by suspended ceilings, the ceiling shall meet ASTM C 635 and ASTM C 636. Additionally, a label limiting relocation of the sprinkler shall be provided on the anchoring component. (NFPA 13-10, 9.2.1.3.3.2 & 9.2.1.3.3.4).

3.4 SPRINKLER DRAINS AND TEST CONNECTION

- A. Provide all necessary drain valves, drain risers, capped nipples, auxiliary piping, etc. as required to drain the system risers and mains, and all trapped portions of the system. Drain valves which are not connected to drain pipes leading to floor drains shall be hose end type.

- B. Main drains and test connections shall be piped to sanitary sewer. Provide air gap at discharge location shown on the plans.

- C. Provide all piping required to spill the drains and test connections to the floor, funnel or other drainage connections provided under the plumbing contract, or arrange with the plumbing trade to provide additional drainage facilities, in which case pay all charges related to the additional plumbing construction work.

3.5 TAGS

- A. Provide all designated signs on shut-off valves, control valves, alarms, etc. as required by the agencies having jurisdiction.

3.6 TESTING

- A. All sprinkler system piping must be hydrostatically tested for a period of two (2) hours in the presence of the Owner or his/her designee, and the DSA Inspector of Record.
- B. Hydrostatic tests shall be made not less than 200psi for 2 hours or 50psi above static pressure in excess of 150psi.
- C. Leakage from any fittings may be corrected by tightening or replacement of defective materials only. Use of sealant materials is expressly prohibited and unacceptable to the Owner as a corrective measure.
- D. Gauges used in testing shall be identified as to accuracy, or provided by Owner, at his/her option.
- E. Blind flanges or inserts used for testing shall be placed in the system and removed from the system in the presence of the Owner or his/her designee. These devices shall be clearly marked and vividly painted to permit casual observance of their addition to the system.

3.7 RECORD DRAWINGS

- A. Keep a current set of Record Drawings on the job at all times. These Drawings shall be updated as changes are made and shall be kept in the Construction Office. Also, see Special Conditions and Fire Protection General, Section 21 00 00.
- B. Keep a current set of Specifications and material lists, with catalog cuts, in the Construction Office at all times.

3.8 CLEAN-UP

- A. Perform the work under this Section so as to keep affected portions of the site neat, clean and orderly at all times. Upon completion of the work under this Section, immediately remove all surplus materials, rubbish and equipment associated with or used in the performance of this work. Failure to perform such clean-up operations within 24 hours of notice by the Architect or General Contractor shall be considered adequate grounds for the work to be done by others at this Sub-Contractor's expense.

3.9 OPERATIONAL AND MAINTENANCE MANUALS

- A. Four (4) complete sets of operational and maintenance (O&M) booklets shall be supplied to the Architect with Record Drawings. One (1) set shall be retained by the engineer of record.
- B. O&M booklets shall be complete and include:
 - 1. Record/As built drawings.
 - 2. Record/As built hydraulic calculations.
 - 3. Material Data.
 - 4. System operation and maintenance instruction.
 - 5. Inspection and Testing Log.

**** END OF SECTION ****

SECTION 21 10 00

UNDERGROUND FIRE SERVICE

PART 1 - PART I - GENERAL

1.1 GENERAL

- A. The General Conditions, any Supplementary Conditions, Section 21 00 00, Fire Protection General, and Division 1 are hereby a part of this Section as fully as if repeated herein.
- B. Section Includes: Description of requirements for materials and installation of site utilities and related work as shown on Drawings and necessary to provide a complete and proper installation.
- C. The work includes under this section consists essentially of, but not necessarily limited to installing new site utilities in areas indicated on Drawings.
- D. Related work:
 - Section 21 00 00 Fire Protection General
 - Section 21 05 00 Overhead Fire Protection Systems

1.2 SCOPE

- A. Furnish all labor, materials, equipment and services required for and/or reasonably incidental to the completion of the following work:
 - 1. Connection to new private fire main shown on civil drawings five feet outside the new buildings with minimum 6" diameter sprinkler main.
 - 2. Underground fire sprinkler mains from five feet outside of new buildings, minimum 6" diameter, complete with in-building riser ending at a flange 12" above finish floor, with a blank flange bolted on top. Risers shall be located as shown on the fire protection drawings.
 - 3. Trenching and backfill for underground sprinkler main to five feet outside building.
 - 4. Backflow assembly, underground check valves, gate valves, post indicators, fire hydrants, and fire department connections beyond five feet outside of building shall be in accordance with Division 33.

1.3 SUBMITTALS

- A. Submit for review, within fifteen (15) days after signing Contract, the required number of copies of a complete list of materials proposed for use, including sizes, capacities, etc. See Division 1 for requirements. This list includes:
 - 1. Piping.
 - 2. Fittings.
 - 3. Valves.
 - 4. Tracer wire.

5. Warning tape.
6. In-Building Riser.
7. Petrolatum Wax Tape for Protection Against Corrosive Soil.
8. Mechanical Joint Restraint.

1.4 COORDINATION

- A. Before submitting a bid for the mechanical work the Contractor shall visit the site and become familiar with all the work on other related Drawings and Specifications, and plan his/her work to provide the best possible assembly of the combined work of all trades. No additional costs will be considered for work which has to be relocated due to conflicts with other trades.

1.5 BUILDING LAWS

- A. Mechanical work shall conform to all requirements prescribed by governmental bodies having jurisdiction and is to be in accordance with the Uniform Plumbing Code, California Mechanical Code, California Fire Code, National Fire Protection Association; California State Code Title 8, Title 21, and Title 24; and the Energy Conservation Standards.
- B. Should any part of the design fail to comply with such requirements, the discrepancy shall be called to the attention of the Architect prior to submitting a bid.
- C. Should there be any direct conflict between the Drawings and/or Specifications and the above rules and regulations, the rules and regulations shall take precedence. However, when the indicated material, workmanship, arrangement or construction is of a superior quality or capacity to that required by above rules and regulations, the Drawings and/or Specifications shall take precedence. Rulings and interpretations of enforcing agencies shall be considered a part of the regulations.
- D. After a Contract is awarded, if minor changes or additions are required by the aforementioned authorities, even though such work is not shown on Drawings or overtly covered in the Specifications, they must be included at the Contractor's expense.
- E. The Contractor is responsible to coordinate and make adjustments in his/her work with the full set of Contract Drawings and Specifications.

1.6 PERMITS, FEES AND UTILITIES

- A. The Contractor shall obtain and pay for all permits and fees. The Contractor shall arrange for all required inspections.

1.7 UTILITY CONNECTIONS

- A. The Contractor shall route site utilities to approximately 5'-0" outside of building, or as shown on Drawings.

1.8 MATERIALS AND WORKMANSHIP

- A. All equipment provided shall deliver full rated capacity at efficiency for which designed. All equipment shall meet requirements indicated and be suitable for installation shown. Notify Architect of any shortcomings found at least ten (10) days prior to bid date. Equipment not meeting all specified requirements will not be accepted even though specified by name along with other manufacturers.
- B. Where two or more units of the same class of equipment are furnished in the same Section of the Specification, provide each from the same manufacturer. Furnish all equipment and materials new and free from defects.
- C. Capacities, dimensions or sizes specified or indicated are minimum. Tolerances used in rating or testing standards specified not allowed in determining capacities of equipment.
- D. Materials and equipment shall be installed in accordance with the manufacturer's application recommendations, requirements, and instructions, and in accordance with Contract Documents. Where manufacturer's instructions differ from those indicated or specified, they shall be brought to Architect's attention for resolution prior to equipment ordering and installation. Where requirements indicated in Contract Documents exceed manufacturer's requirements, Contract Documents shall govern.
- E. All non-metallic piping below grade shall have tracer wire and warning tape installed as part of this scope of work.

1.9 SITE CONDITIONS

- A. Information on Drawings relative to existing conditions is approximate. During progress of construction, deviations found necessary to conform to actual conditions shall be reported to Architect for determination of procedure to be followed. Contractor is responsible for any damage caused to existing systems. Promptly notify Architect if utilities are found which are not indicated.
- B. Existing equipment, piping, wiring, construction of City sidewalk, street, etc. which interferes with work of this Section shall be removed and promptly returned to service. Replace damaged items with new material to match existing. The City of Brentwood and private utilities must be informed of property owned by them that has been damaged and replaced.
- C. Remove materials not required for present or future use of facility and not claimed by Owner shall become the property of the Contractor and shall be removed from the premises. Consult Owner before removing any material from the premises. Materials claimed by the Owner shall be removed carefully to prevent damage and delivered on-site where directed.
- D. Existing piping and wiring not reused and concealed in building construction may be abandoned in place, but all such piping and wiring which is exposed or indicated to be removed shall become the property of the Contractor and shall be removed from the premises.
- E. Verify all dimensions, lines, and levels at the site for all work specified herein. All inverts, slopes, and elevations shall be established by instrument working from established datum. Provide elevation markers and lines for Owner's use in determining that slopes and

elevations are in accordance with contract requirements. Accurately locate trenches in relation to building and boundary lines as indicated.

1.10 PART II - PRODUCTS

PART 2 - PART II - PRODUCTS

2.1 PIPING AND MATERIALS

- A. Fire and sprinkler mains to 5'-0" from the building shall be Manville "Blue Brute" PVC, FM Class 200, DR14, "Certainteed" C900, or approved equal, with ringtite joint for 4" or larger. Lubricate per manufacturer's recommendations (see Thrust Block detail). For 3" and smaller, Schedule 40 PVC pipe with solvent joints (rated at 200 PSI fittings).
- B. Tracer wire for all non-metallic piping shall be minimum size #10 AWG copper wire with U.L. approval for direct-burial with an insulating jacket of Yellow Color. Piping shall have a contiguous trace wire strapped to the pipe every 5 lineal feet and shall be accessible at every riser and in-grade valve box. Contractor shall provide both warning tape and trace wire for all underground piping.
- C. All fire and sprinkler service materials shall be new and currently listed in the Underwriters' laboratories, Inc. Fire Protection Equipment List and shall be acceptable to DSA. Material that is pending approval shall not be acceptable.
- D. All underground piping shall be installed in strict accordance with the manufacturer's installation guide.
- E. Sprinkler mains shall be cement lined class 50 ductile iron when installed to within 5'-0" of building and under all footings and slabs.
- F. All metallic piping fittings shall be coated and wrapped. Metallic piping and fittings shall be polyethylene encased for corrosive soil conditions.
- G. All bolt-up sets (nuts, bolts, and washers) and tie rods for valves, fittings, and buries shall be stainless steel, ASTM A-276 Type 316.
- H. Backfill shall be accomplished in strict accordance with the manufacturer's installation guide and the "Backfill" Section of these Specifications.
- I. Tamper-proof switches shall be 120 V tamper switches for each isolation and control valve in each area. Electrical wiring and annunciating. Tamper switches shall be CSFM approved.
- J. In-Building Riser: Ames series IBR, 304 stainless steel, UL/FM approved.

2.2 VALVE BOXES

- A. Valve boxes shall be of cast iron, screw adjustable type with loose cast iron cover as manufactured by M&H, Mueller, Iowa or Pacific States Cast Iron. Covers shall be lettered "Water" or as detailed and specified on Drawings.

2.3 THRUST BLOCKS

- A. Provide concrete thrust blocks at all changes in direction of fire and fire sprinkler main. Minimum face area against undisturbed soil shall be 6 ft² on water mains, or as indicated; 1/2" diameter rods shall be bent around pipe and anchored into 2000 lb strength concrete. Thrust blocks shall be provided in addition to mechanical joint restraint per local fire marshal.

2.4 MECHANICAL JOINT RESTRAINT

- A. Provide mechanical joint restraint at all changes in direction of the fire and fire sprinkler mains. Mechanical joint restraint for C900 PVC pipe shall be EBAA Iron Megalug series 2000PV or approved equal. Mechanical joint restraint for ductile iron pipe shall be EBAA Iron Meglug series 1100 or approved equal.

2.5 VALVES

- A. All valves shall be the product of a single manufacturer, Mueller, Stockham, Kennedy or Clow. Valves shall be mechanical joint and be AWWA approved.

2.6 POLYETHYLENE ENCASEMENT

- A. All metallic pipe fittings and appurtenances below grade shall be wrapped for protection from corrosive soil with a minimum of 8 mil polyethylene encasement in accordance with ANSI/AWWA C105/A21.5. Polyethylene encasement shall be US Pipe Polyethylene Encasement or approved equal.

PART 3 - EXECUTION

3.1 GENERAL REQUIREMENTS

- A. Prior to bid, visit the job site and familiarize with local conditions, including verification of the location of the existing utilities.
- B. All fire and sprinkler piping shall be installed in a manner acceptable to the local CFMS and DSA and the Rating Agency.
- C. All fire and sprinkler piping shall be pressure tested and flushed according to the procedures set forth in NFPA 13, NFPA 14, and NFPA 24, and witnessed by the General Contractor and the DSA Inspector of Record.
- D. This Contractor shall be responsible for any damage to other work caused by this installation or by leaks in the fire protection lines.
- E. This contractor shall be responsible for coordinating his/her work with the General, Electrical, Mechanical, and Plumbing Contractors, and with other trades.

3.2 EXCAVATION AND BACKFILL

- A. Perform all necessary excavation and backfill required for installation of mechanical work. Any work damaged during excavation and backfilling shall be repaired at Contractor's expense.
- B. Trenches are to be excavated to necessary depth and width. Provide additional excavation to facilitate crossovers, additional offsets, etc. as required. Excavation material is unclassified. Width of trench adequate for proper installation of piping.
- C. Bedding shall be on minimum 6" deep layer of sand placed on leveled trench bottom. Sand removed to necessary depth for piping bells and couplings to maintain contact of pipe on sand for entire length. All other piping laid on smooth level trench bottom to maintain contact for entire length.
- D. All backfill shall be bank run sand and/or gravel to 6" above piping up to slab on interior piping below slabs. All backfill placed in layers not exceeding 8" deep and compacted to 95% of maximum density at optimum moisture content per AASHTO Standard T-99.
- E. During progress of work, Owner may have compaction tests made under direction of testing laboratory for all compacted fill. If found not to meet Specification, Contractor shall excavate and recompact fill at no additional cost to Owner.
- F. Following backfilling, grade all trenches to level of surrounding subgrade. All excess soil shall be located per Owner's instructions.

3.3 SETTING OF THRUST BLOCKS

- A. Thrust Blocks: Plugs, caps, tees, and bends deflecting 22 1/2° or more, either vertically or horizontally, on water lines 4" in diameter or larger and fire hydrants shall be provided with thrust blocking. Thrust blocking shall be concrete of a mix not leaner than 2 parts cement; 2 1/2 parts sand; 5 parts gravel; and having a compressive strength of not less than 2,000 PSI at 28 days. Blocking shall be placed between solid ground and the hydrant or fitting to be anchored. Unless otherwise indicated or directed, the base and thrust bearing sides of thrust blocks shall be poured directly against undisturbed earth. The sides of thrust blocks not subject to thrust may be poured against forms. The area of bearing shall be as shown or as directed. Blocking shall be placed so that the fitting joints will be accessible for repair.

3.4 REQUIREMENTS OF REGULATORY AGENCIES

- A. In addition to requirements shown or specified, comply in general with applicable portions of latest current local and/or State ordinances and codes.
- B. Include all items of labor and material required to comply with such standards and codes. Where quantities, sizes or other requirements indicated are in excess of standard or code requirements, specified requirements shall govern.

3.5 COORDINATION

- A. Do all work to receive or joint with work of all trades; cut new service into existing mains; extend piping; and make necessary connections as required to prevent interruption of

service. All work shall be coordinated with work of other trades to provide clearances for installation and maintenance of all mechanical equipment. Drawings and Specifications are arranged for convenience only and do not necessarily determine which trades perform various portions of the work.

- B. Before shutdown of any utility service for new connections, coordinate with and notify Owner, County, and utility company(s). Contractor to verify with Architect for approval for areas of interference with existing facilities and operation of departments before doing any work. Contractor to work out schedule of construction and get approval by Architect before starting any work.

3.6 DRAWINGS

- A. Drawings are diagrammatic and do not show all offsets, bends, elbows, etc. which may be required for proper installation of work. Such work shall be verified by Contractor at building site. Provide additional bends and offsets as required by riser and main locations, or other conditions, to complete work at no additional cost to Owner.
- B. Drawings and Specifications are complementary and what is called for by one shall be as binding as if called for by both. Items indicated are not necessarily included in Specifications. Specifications shall supersede Drawings in case of conflict.

3.7 TESTING

- A. Test all piping, valves, clean-outs, etc. as listed below and provide the Architect with certified copies of test results. The inspection authority having jurisdiction and the supervising Architect shall be notified at least 24 hours prior to performance of all tests so that they may be witnessed.
 - 1. All new fire main piping shall be hydrostatically tested to 200 PSI for 2 hours in the presence of the Local Fire Marshall and DSA Inspector of Record.

**** END OF SECTION ****

SECTION 22 0000
PLUMBING

PART 1 - GENERAL

1.01 SUMMARY

- A. The Contract Documents, including General Conditions and Supplemental General Conditions, and all Division 01 Sections apply to the work of this Section.

- B. Section includes
 - 1. A complete system of soil, waste, vent and sanitary sewer piping and structures, including provisions for mechanical equipment drainage; and connection of same to public sanitary sewers, located as indicated on the Drawings.
 - 2. Cold water distribution system, complete, from points of contact with site domestic water systems, located approximately as indicated on the Drawings, to all plumbing fixtures, mechanical equipment, building specialties, and Owner supplied equipment scheduled for service on the Drawings.
 - 3. Hot water distribution system, complete, from serving water heaters and/or points of contact with site domestic hot water, to all plumbing fixtures, mechanical equipment, building specialties, and Owner supplied equipment scheduled for service on the Drawings.
 - 4. Cold water distribution system, complete, from points of contact with site domestic water systems, located approximately as indicated on the Drawings, to all plumbing fixtures, mechanical equipment, building specialties, and Owner supplied equipment scheduled for service on the Drawings.
 - 5. Gas piping system, complete from point of connection with site gas piping (located approximately as indicated on the Drawings) and terminating in stopcocks adjacent to all gas-fired equipment, as noted on the Drawings. Gas pressure regulator and shut-off valve shall be provided at building entrance, located as shown on the Drawing.
 - 6. All plumbing fixtures and trim as scheduled on the Drawings, inclusive of setting of fixtures and connections to drainage and water supply systems.
 - 7. Storm water drainage systems within the building, inclusive of roof drains and copper, steel, or cast iron storm water leaders, to points of contact with site drainage system.
 - 8. Flashing of all plumbing pipe penetrations through exterior walls, roofs, and foundations.
 - 9. Excavation and backfill as required for the work of this Section in conformity with Division 31 of these Specifications.
 - 10. Final connection of water and natural gas to equipment furnished under other Sections.
 - 11. Protection of all piping specified herein and/or shown on the Drawings, from freezing. Buried piping shall be a minimum of 12" below the local frost line. If ambient design temperature is 30°F or less, all pipes in unconditioned spaces shall be insulated.
 - 12. Testing and adjusting of all piping systems and equipment herein specified.
 - 13. Sterilization of domestic water systems.
 - 14. Pipe wrapping and insulation.

- C. Related work specified in other Sections
 - 1. Sealants, firestopping, sheet metal flashing and trim: Division 07.
 - 2. Basic electrical requirements, line voltage wiring: Division 26 - Electrical.
 - 3. Finish painting: Division 09.

1.02 QUALITY ASSURANCE

- A. Codes and Standards: Comply with all applicable codes and standards as stated herein and as described in Section 01 4200, including the following:
1. California Building Code (CBC)
 2. California Plumbing Code (CPC)
 3. California Fire Code (CFC)
 4. California Energy Conservation Code, Title 24
 5. California Administrative Code (CAC) Title 8, Title 17, and Title 24
 6. California Electric Code (CEC)
 7. Comply with all ADA requirements for disabled access.
 8. City Fire Marshal requirements
 9. NSF/ANSI 61 Standard, *Drinking Water System Components - Health Effects*, for fixture materials that will be in contact with potable water.
 10. AB 1953, Amendments to Section 116875 of the Health and Safety Code relating to lead plumbing.
- B. Minimum requirements: The requirements of these are the minimum that will be allowed unless such requirements are exceeded by applicable codes or regulations, in which the regulatory codes or regulation requirements shall govern.

1.03 SUBMITTALS

- A. All submittals shall be submitted under the provisions of Division 01 and the following.
1. Product Data: For each type of product.
 - a. Submit cut sheets for each plumbing fixture. Include selected fixture and trim, fittings, accessories, appliances, appurtenances, equipment, and supports and indicate materials and finishes, dimensions, construction details, and flow control rates for each fixture indicated.
 - b. Submit manufacturer's product data for all plumbing piping, fittings, materials, and equipment.
 2. Shop Drawings:
 - a. Prepare complete consolidated and coordinated layout drawings for all new systems, and for existing systems that are in the same areas. Shop drawings shall be prepared using AutoCAD 2013 or newer and shall be drawn at a minimum $\frac{1}{4}'' = 1' - 0''$ scale. Sections, details, and diagrams shall be to required scales for specified areas. Include diagrams for all piping, and power, signal and control wiring.
 - b. Complete and detailed shop drawings shall be maintained throughout the coordination and construction phase, indicating all equipment and trades' work clearly. All equipment including piping, etc. shall clearly identify both top and bottom elevations as well as distances from equipment to established building lines. Coordinate with other trades and field conditions and show dimensions and details including building construction and access for servicing.
 - c. Use of contract documents for shop drawings is not acceptable.
 - d. Submit shop drawings to Architect for approval, prior to fabrication or installation of any work. Do not install equipment or piping until layout drawings have been approved.
 - e. Any work installed without prior shop drawing approval shall be removed at the Contractor's expense.
 3. Welding
 - a. Before any welding is performed, the contractor shall submit to the Architect, copies of any welding procedure specifications and their supporting procedure qualification

records for review and acceptance. Copies of welder qualification records shall be made available for review to the owner or his representative at the construction site.

4. As-Built Drawings
 - a. A complete set of Contract Drawings shall be maintained at the work site, and all changes in the work shall be recorded on this set on a daily basis. In addition to changes made during course of work, show the following:
 - 1) Exact location, type and function of concealed valves and controllers.
 - 2) Exact size, elevations and location of underground and under floor piping.
 - b. Submit to Architect for final approval.
 5. Operation & Maintenance Data
 - a. Contractor shall provide all operating and maintenance instructions provided by the manufacturer, describing proper operation and maintenance of any equipment and devices installed. Operating and maintenance instructions shall cover maintenance, adjustment, and operation of each piece of apparatus, including preventative maintenance schedule and procedures.
 - b. Contractor shall also provide a parts list of all equipment and component parts for all equipment under this Section. The equipment list shall include manufacturer's name, model number, and local representative, service facilities and normal channel of supply for each item.

Also include the following:

 - 1) Manufacturer's certified shop drawings, and lubrication charts and data. Mark each sheet with equipment identification number and actual installed condition or system and location of installation. Specifically identify which options are provided.
 - 2) Description of start-up and operating procedures for each system. including controls diagrams and description of operating sequences.
 - 3) Recommend preventative maintenance schedule and procedures.
- B. Submit data to the Architect for approval. Final acceptance of the work will not be made until a satisfactory submission of this material is received and approved by the Architect.

1.04 ACCURACY OF DATA

- A. The data given herein and on the Drawings are as exact as could be reasonably secured, but absolute accuracy is not guaranteed. Exact locations, distances, elevations, etc. will be governed by shop drawings, the building itself, and actual field conditions.

1.05 UTILITY CONNECTIONS

- A. Provide all services within the building to a point 5' outside of building. Arrange for all utility connections, determine their exact requirements, and pay all costs incurred unless indicated otherwise.
- B. Send proper notices, make necessary arrangements, and perform other services required for care and maintenance of all utilities and assume all responsibility concerning same. Observe all rules and regulations of the respective utilities in executing the work.

1.06 DAMAGE BY LEAKS

- A. Contractor shall be responsible for any damage to work of other Contractors that is caused by leaks in any temporary or permanent piping systems due to pipe rupture, disconnected pipes or fittings, or by overflow of equipment.

1.07 LICENSING REQUIREMENTS

- A. All plumbing systems shall be installed by a C-36 Plumbing Contractor. Plumbing systems include: waste removal and connection of on-site waste disposal systems; piping, storage tanks, and venting for supply of gases and liquids for any purpose; all gas appliances, flues, and gas connections; water and gas piping from the owner's side of utility meter to the structure or fixed works; installation of any type of equipment to heat water or fluids to a suitable temperature; and maintenance and replacement of the items described above, including health and safety devices.

1.08 COORDINATION

- A. All work shall be coordinated with water, gas, sanitary sewer, and other services on the site. The locations of points of connection to the site services shall be confirmed prior to commencement of work.
- B. Coordinate roughing-in and final plumbing fixture locations and verify that fixtures can be installed to comply with original design and referenced standards.

PART 2 - PRODUCTS

2.01 PRODUCTS CRITERIA

- A. Only specified materials shall be utilized in the work of this Section unless substitutions have been approved in accordance with the General Conditions and Division 01 Sections of the Specifications.
- B. All materials, appliances, and equipment shall be new and best of their respective kinds, free from defects, and of the make, brand or quality specified or as accepted by the Architect.
- C. Multiple Units: When two or more units of materials or equipment of the same type or class are required, these units shall be products of one manufacturer.
- D. All fixtures, materials, and equipment equal in quality and utility to these herein mentioned will be accepted. When specific names are used in describing fixtures, materials, and equipment they are mentioned as standards only, but this implies no right on the part of the Contractor to use other fixtures, materials and equipment, or methods, unless approved as equal in quality and utility by the Architect. The decision of the Architect shall govern as to what fixtures, materials, and equipment are equals to those mentioned, but the burden of proof as to the quality of any proposed fixtures, materials, or equipment shall be upon the Contractor. If any tests are necessary to determine the quality of proposed fixtures, materials, or equipment, an unbiased laboratory shall make such tests at the expense of the Contractor satisfactory to the Architect.

2.02 PIPE, FITTINGS

- A. General
 - 1. Tracer wire shall be installed with all non-metallic piping below grade. Tracer wire shall be solid core copper, 14 gauge minimum, laid continuously along pipes. Wire shall be "ty-wrapped" to pipe at eight feet on center. Tracer wire shall terminate in concrete access boxes at the beginning and terminal ends of the buried pipe.
 - 2. All accessible pipe 2" and smaller shall be threaded. Fittings for threaded pipe shall be 150-lb. malleable iron, screwed and banded.
 - 3. Vent piping shall have vandal resistant mushroom vent caps.

- B. Below Grade Waste, Drain, and Vent Pipe: Because of the highly corrosive nature of the native soil at the project site, no steel or cast iron pipe shall be used below grade.
1. Solid wall Schedule 40 PVC pipe meeting the requirements of ASTM D 2665, drain, waste and vent
 2. PVC socket fittings: ASTM D 2665, made to ASTM D 3311, drain, waste and vent patterns and to fit Schedule 40 pipe. .
 3. Solvent cement: ASTM D 2564
- C. Above Grade Waste, Drain, and Vent Pipe:
1. Lines 2 inches and larger shall be of standard weight no-hub cast iron soil pipe and fittings and shall conform to the requirements of CISPI Standard 301 and ASTM A88. All pipe and fittings shall be marked with the collective trademark of the Cast Iron Soil Pipe Institute ® and listed by NSF® International. All pipe and fittings shall be produced by a single manufacturer. AB&I, Charlotte, or Tyler.
 2. Lines under 2 inches shall be galvanized steel, with threaded cast iron drainage fittings.
 3. Joints: Hubless Couplings shall conform to CISPI Standard 310 and local code requirements. Couplings shall be manufactured in the United States and be certified by NSF® International. Heavy Duty and Medium Duty couplings shall conform to ASTM C 1540. Hubless coupling gaskets shall conform to ASTM C-564. Couplings 1-1/2" through 4" shall have four bands and 5" through 10" shall have six bands.
 - a. Piping 2" and smaller: Medium duty no-hub couplings, Husky 2000, Tyler Wide Body, Clamp-All 80.
 - b. Piping 2½" and larger: Heavy duty no-hub couplings, Husky 4000, Mission, or Clamp-All 12.
 - c. Couplings shall be installed in accordance with the manufacturer's band tightening sequence and torque recommendations. Tighten bands with a properly calibrated torque limiting device.
 4. At the option of this Contractor, all soil, waste, and vent piping above ground may be DWV copper, with wrought copper fittings, with "Stay-Safe 50" lead free solder and a suitable non-corrosive flux.
- D. Hot & Cold Water Piping
1. All domestic hot and cold water piping 3" and smaller shall be Type L, hard temper, copper pipe with wrought copper or cast brass solder joint fittings or ProPress fittings. Pipe shall be NSF 61 Certified and bear the NSF Certification mark. All joints shall be made up with lead free solder. A suitable non-corrosive flux shall be used at all joints.
 - a. Viega Copper Press fittings: Copper and copper alloy press fittings shall conform to material requirements of ASME B16.18 or ASME B16.22 and performance criteria of IAPMO PS 117. Sealing elements for press fittings shall be EPDM. Sealing elements shall be factory installed or an alternative supplied by fitting manufacturer. Press end shall have SC (Smart Connect) feature design (leakage path).
 2. Pipes below grade inside buildings shall be soft drawn, Type L or K copper with no joints below slabs. Pipes shall be sleeved with 20-mil plastic sheathing.
- E. Condensate Drainage Pipe:
1. Condensate drainage piping shall be Anvil, Mueller, Watts, or approved equal.
 - a. 1 ¼ inch and larger shall be type DWV copper tube, ASTM B306.
 - b. 1 inch and smaller shall be type M, hard temper copper, standard copper fittings.
 2. Drainage fittings shall be ASME B16.23, cast copper or ASME B16.29, wrought copper, solder-joint fittings. 1 ¼ inches & smaller, standard pressure fittings.
 3. Solder shall be ASTM B 32, lead free with ASTM B 813, water-flushable flux.

2.03 VALVES, SPECIALTIES

A. General Requirements:

1. All valves, except pressure reducing and control valves, shall be the same size as the pipe to which they are installed.
2. All valves of a particular type and size range shall be the product of one manufacturer.
3. Valve body materials shall be compatible with piping system materials.
4. Provide a union immediately downstream from each valve, unless the valve is flanged.
5. All valves shall be installed with the stem 45 degrees above horizontal, if possible. In no case shall the stem be installed below horizontal.
6. Where insulation is indicated, install extended stem valves arranged in proper manner to receive insulation.

B. Ball Valves (threaded): Valves shall be rated 600 PSI non-shock CWP and have 2-pc. Lead-free dezincification-resistant body, end piece, stem and ball, TFE seats, full port, separate pack nut with adjustable stem packing and anti-blowout stems. Valves ends shall have full depth ANSI threads. Valves shall be 3rd party certified to Annex G of NSF/ANSI 61. Nibco T-685-80-LF, Watts LFB-6080, or KITZ 858.

C. Ball Valves (solder): Nibco S-685-80-LF, Watts LFB-6081, or KITZ 859; two piece, full port, lead free, lever handle, 600 psi CWP

D. Gate Valves:

1. 3" and smaller shall be Nibco T134, Stockham B-120, KITZ 42T; bronze body, union bonnet, rising stem, solid wedge, 150 lb. with wheel handle.
2. Larger than 3" shall be Nibco F-617-0 or KITZ 72; iron body, bolted bonnet, outside screw and yoke, solid wedge, 125 lb. with wheel handle.

E. Lift Check Valves (vertical): Nibco T-480-Y-LF or KITZ 836; bronze body, inline lift type, Teflon seat, and discs, spring actuated, 125 lb.

F. Swing Check Valves (horizontal): Nibco T-413-Y-LF, Stockham B-345, or KITZ 822T; bronze body, Y-pattern swing-type, rated 200 PSI non-shock CWP. Body, bonnet, and disc hanger shall be of lead-free dezincification-resistant material and TFE seat disc. Valve ends shall be threaded type. Valves shall be 3rd party certified to Annex G of NSF/ANSI 61.

G. Gas Shut-off Valves:

1. At Building Service: Homestead Fig. 601, pressure Class 125 lubricated plug valve, cast iron, lever handle, 200 lb., leak and hydro tested. Install BrassCraft Safety Plus seismic actuated shut off valve at meter (or entrance to building if not new construction). Brace per manufacturer's instructions.
2. At Connection to Equipment: Jomar T-203 gas ball valves, 2-piece design, threaded connection; 2 "Viton" o-rings; 1/8-inch side tap; leakproof stem. Provide with AGA/CSA certified stainless steel flex connection 12" max.

H. Gas Pressure Regulators: American Meter, Series 1813B. Regulators shall be sized for full gas capacity of equipment as scheduled on the Drawings. Inlet pressure shall be 3 psig. Outlet pressure shall be 7" water column. Regulators installed indoors shall have relief opening piped to outdoors. Size relief pipe in accordance with ANSI Z223.1 "National Fuel Gas Code".

I. Water Pressure Regulating Valves: Wilkins 500 YSBR series. Install where pressure to building exceeds 70 psi.

- J. Backflow Preventers (Where shown on the Drawings or required by local code):
1. Atmospheric type: Wilkins #35 series
 2. Pressure type: Wilkins #720A series
 3. Reduced pressure type:
 - a. 1/4" to 2" - Wilkins #975-XLMS series
 - b. 2 1/2" to 10" - Wilkins #375 series
- K. Thermostatic Mixing Valves
1. Watts LFMMV series or approved equal. The mixing valve shall be installed on the hot water supply to fixture. The valve shall be ASSE 1017, ASSE 1069, ASSE 1070 and IAPMO cUPC listed. It shall have a lead-free cast copper silicon alloy body. The valve shall include integral filter washers and check valves and an adjustment cap with locking feature.
- L. Hose Bibbs
1. HB-1: Interior Hose Bibbs: Chicago No. 387-E27CP, wall mounted, chrome plated inside sill fitting; full flow, inline vacuum breaker with hose thread outlet; tee handle with square tapered broach; 3/4" NPT female thread inlet. Slow compression rebuildable cartridge; slip wall flange. Provide a Chicago No. 1771ABCP loose key stop at each hose bibb.
 2. HB-2: Exterior Hose Bibbs: Narrow Wall Hydrants: Zurn Z-1350EZ, or equal Jay R Smith, enclosed moderate climate for narrow wall installation. Bronze body & interior parts; replaceable seat washer, screwdriver operated stop valve in supply; key operated control valve, 3/4 IP female inlet and 3/4 male hose connection; stainless steel box and hinged cover with cylinder lock and "WATER" stamped on cover. Complete with mounting brackets and hardware.

2.04 UNIONS

- A. Steel pipe unions shall be malleable iron, 150 lb., ground joint, Anvil Fig. 463 or equal.
- B. Copper pipe unions shall be soldered joint, Nibco series 633 or 733, Mueller, or equal.
- C. Dielectric unions shall be Epco, Watts, Wilkins, or equal.

2.05 DIELECTRIC FITTINGS

- A. Precision Plumbing Products, "Clear Flow" series, threaded dielectric fittings, sizes 19100P thru 19195P.
- B. Dielectric fittings shall have zinc electroplated steel casing, and NSF/FDA listed lining. Fittings shall meet the requirements of ASTM standard F1545 for continuous use at temperatures up to 225°F (- +5°F) and for pressures up to 300 psi, and shall achieve a dielectric waterway in all potable water and appropriate HVAC applications

2.06 PIPE INSULATION

- A. Insulate all hot water supply piping, all hot water return piping, all tempered water supply piping and all tempered water return piping with Johns Manville "Micro-Lok HP", or equal, rigid fiberglass one-piece pipe insulation or Knauf Insulation "Earthwool 1000°" or "Earthwool Redi-Klad 1000° rigid glass mineral wool one-piece pipe insulation, or approved equal.
- B. Pipe covering shall have factory applied All Service Jackets (ASJ). Jackets shall be constructed of high density, white kraft bonded to aluminum foil with fiber glass yarn, with a pressure sensitive closure system, or of aluminum foil reinforced with a glass scrim bonded to a kraft paper

interleaving with an outer film layer leaving no exposed paper. Adhesives or staples shall not be required to seal the jacket and butt strips.

- C. All insulation shall have composite (insulation, jacket, tape seal, and adhesive used to adhere the jacket to the insulation) Fire and Smoke Hazard ratings as tested under Procedure ASTM E 84 and NFPA 255, not exceeding: Flame Spread - 25, Smoke Developed - 50. PVC fitting covers, jacketing and accessories such as adhesives, mastics, cements and cloth for fittings should have the same component ratings.
- D. Insulation thickness shall conform to Title 24, Part 6 requirements as indicated in the following table:

| FLUID TEMPERATURE RANGE (°F) | CONDUCTIVITY RANGE (in Btu-inch per hour per square foot per °F) | INSULATION MEAN RATING TEMPERATURE (°F) | NOMINAL PIPE DIAMETER (in inches) | | | | |
|--|--|---|---|-----------|-----------|---------|-----------|
| | | | 1 and less | 1 to <1.5 | 1.5 to <4 | 4 to <8 | 8 and lrg |
| | | | INSULATION THICKNESS REQUIRED (in inches) | | | | |
| Space Heating, Hot Water Systems (steam, steam condensate and hot water) and Service Water Heating Systems | | | | | | | |
| Above 350 | 0.32-0.34 | 250 | 4.5 | 5.0 | 5.0 | 5.0 | 5.0 |
| 251-350 | 0.29-0.31 | 200 | 3.0 | 4.0 | 4.5 | 4.5 | 4.5 |
| 201-250 | 0.27-0.30 | 150 | 2.5 | 2.5 | 2.5 | 3.0 | 3.0 |
| 141-200 | 0.25-0.29 | 125 | 1.5 | 1.5 | 2.0 | 2.0 | 2.0 |
| 105-140 | 0.22-0.28 | 100 | 1.0 | 1.5 | 1.5 | 1.5 | 1.5 |

- E. Fittings, valves and flanges shall be covered with Manville "Zeston 2000" insulated PVC fitting covers and Hi-Lo Temp insulation inserts or Knauf "Proto LoSmoke". Insulation for all exposed piping and all piping in crawl spaces shall be covered with Zeston PVC jacketing. PVC jackets shall be 20 mils thick and shall be bonded with Zeston Perma-Weld adhesive. In crawl spaces, Knauf Earthwool RediKlad 1000° pipe covering shall serve as an acceptable alternate to standard pipe covering and PVC.
- F. All piping exposed to the weather shall be finished with aluminum jacketing with a laminated moisture retarder or Earthwool RediKlad 1000° with Venture Clad embossed jacket. Aluminum jacketing shall be overlapped 2 to 3 inches and held in place with stainless steel bands to form a weather tight system. Elbows and tees shall be fitted with matching aluminum fitting covers. Other fittings in metal-jacketed systems shall be finished with conventional weather-resistant insulating materials with painted aluminum finish.
- G. All domestic water piping below grade shall be insulated with Dow Trymer-2000. Pipes shall be sleeved with 30 mil PVC jacket, with glued joints.

2.07 ROOF DRAINS

- A. RD-1 (Combination Roof/Overflow Drain): Zurn Z-164 (12") or approved equal, 12 diameter roof and overflow drain combination. Dura-Coated cast iron bodies with combination membrane flashing clamp/gravel guards, double top set deck plate, and low silhouette cast iron dome.

1. Downspout Nozzle: Zurn ZANB199, nickel bronze body, threaded inlet and decorative face of wall flange and outlet nozzle

2.08 FLOOR DRAINS

- A. Floor Drains: Drains in membrane dampproofed floors shall have flashing flange and membrane clamp. Drains in sheet vinyl floors shall have a 14" square latex flange.
 1. FD-1: Zurn ZN-4156S-P or equal Jay R Smith. Dura-Coated cast iron body with bottom outlet, combination invertible membrane clamp and adjustable collar with seepage holes, primer connections and "Type S" polished, nickel bronze, square heel-proof, light-duty strainer. 2" pipe size. 6" x 6" square top grate.
 2. HD: Watts Drainage FD-830-7, 3 inch pipe size; epoxy coated cast iron hopper drain with 12" x 12" square open top; trap primer tapping.

2.09 FLOOR SINKS

- A. Where shown on Drawings, floor sinks shall be as follows:
 1. FS-1: Zurn Z-1901-P-2, or equal Jay R Smith. 12" x 12" x 8" deep, white acid resisting interior, aluminum anti-splash interior dome strainer, 1/2" grate, 2" size. Set rim flush with finished floor.

2.10 CLEANOUTS

- A. Cleanouts in membrane dampproofed floors shall have flashing flange and membrane clamps. Plugs shall be bronze, with cast iron body ferrule for cast iron pipe.
- B. Floor Cleanouts (FCO): Zurn ZN1400-HD, "Level-trol" adjustable floor cleanouts, dura-coated cast iron with gas and water-tight ABS tapered thread plug, and round scoriated top, adjustable to finished floor.
- C. Grade (COTG): Zurn Z1474-N or equal Jay R Smith. Housing to be dura-coated cast iron body with integral anchor flange and scoriated cover with lifting device. Cleanouts in un-paved areas shall be set in 18" x 18" x 4" concrete pads.
- D. Accessible:
 1. Cast iron pipe: Zurn Z-1440, dura-coated with gas and water-tight, bronze, taper thread plug
 2. Steel pipe: Zurn Z-1470-A bronze, raised head, cleanout plug.
 3. Copper tubing: Nibco figure 816 or 817.
- E. Wall Cleanouts (WCO):
 1. Copper tubing: Nibco figure 816 or 817, with Zurn Z-1462, 6" x 6" polished chrome-plated bronze wall plate and frame.
 2. Cast iron pipe: Zurn Z-1441, dura-coated with gas and water-tight bronze, taper thread plug and round smooth stainless steel access cover with securing screw
 3. Steel pipe: Zurn Z-1468, round stainless steel wall access cover, complete with securing screw and bronze raised hex head plug for steel pipe.

2.11 SLEEVES, WALL PLATES

- A. Service pipe through exterior walls, roofs; interior walls, ceilings: Sioux Chief or equal, wall and ceiling plates; chrome plated at finished rooms.

- B. Pipes through, under footings: 18 gauge iron sleeves two diameters larger than pipe, cast in concrete, annular space filled with mastic or plastic bituminous cement.
- C. Pipes through fire rated walls and through 1-hour walls shall be protected with fire retardant mastic as detailed on the drawings. Installation shall be in full accordance with the requirements of the UL system number. Hilti or approved equal.
- D. Pipes through floors, interior concrete walls, and through fire rated walls and smoke stop partitions: 18 gauge iron sleeves, two diameters larger than pipe, annular space filled with 3M Brand Fire Barrier CP-25 caulk.

2.12 SHOCK ABSORBERS

- A. Zurn Z1700 "Shoktrol" series, or equal Jay R Smith, stainless steel bellows. Install with gate valve shut-off and access door at all flush valves or other automatic valves. A single unit sized in accordance with the manufacturer's recommendations may serve batteries of valves.

2.13 TRAP PRIMERS

- A. Precision Plumbing Products model P-2, adjustable to line pressure, automatic trap primer with all bronze body, integral vacuum breaker, non-liming internal operating assembly with gasketed bronze cover. Install with shut off valve and access doors in Janitor's closets, Mechanical Rooms and other areas not served by, or in close proximity to, flushometer valve operated water closets.

2.14 ACCESS PANELS

- A. Where construction is not inherently accessible, provide adequately sized and conveniently located access doors in ceilings, walls, and furring for access to controls and for servicing valves, equipment, etc.
 - 1. Fire Rated walls and ceilings: Milcor, Style UFR, U.L. Class B, 1½ hour rating, insulated, self closing, self latching, flush key operated cylinder lock, interior latch release. Minimum size shall be 12" x 12". Provide larger sizes where required.
 - 2. Drywall ceilings or walls: Milcor, Style DW, prime coated steel, flush screwdriver-operated cam lock. Minimum size shall be 12" x 12". Provide larger sizes where required.
 - 3. Masonry and tiled walls: Milcor, Style M, prime coated steel, flush screwdriver-operated cam lock. Tiled walls shall have satin finish stainless steel. Minimum size shall be 12" x 12". Provide larger sizes where required.
 - 4. Plastered walls and ceilings: Milcor, Style K, prime coated steel, flush screwdriver-operated cam lock. Minimum size shall be 12" x 12". Provide larger sizes where required.
- B. Doors shall be delivered to the General Contractor for installation.

2.15 VALVE BOXES

- A. Christy #F-08, complete with concrete cover and required extensions. Index all covers "GAS" or "WATER" as required for service use.

2.16 STRAINERS

- A. For pipes 1 ½" - 2": NIBCO T/S 221/222-A or Wilkins S or YB series strainer, 20 mesh type 304 stainless steel screen, bronze construction 200 psi CWP or approved equal. Provide with hose bibb drain.

- B. For pipes 2 ½" & larger: NIBCO F-721A or Wilkins F series, flanged, 125 lb., tapped bolted bonnet with plug and stainless steel screen.

2.17 THERMOMETERS

- A. Weksler "Adjust-Angle", or equivalent Weiss, with separable sockets and 6" minimum scale reading 30-240°F.

2.18 FIXTURES

- A. The quantity and location of fixtures shall be taken from the Architectural and Plumbing drawings. Provide adequate supports and all standard trim normally furnished for fixtures. All enamel shall be acid resisting. Traps, unless otherwise noted shall be 17 gage brass tubing, chrome plated when exposed.
- B. Submit catalog cut-sheets on all fixtures.
- C. Except as otherwise shown, provide ¼" steel backing plates, 36" wide by 12" high minimum size, secured to a minimum of three studs by welding, or with ¼" x 2½" lag screws for all wall hung fixtures for which no other means of support is specified.
- D. Stops and supplies: Provide stops for all fixtures. Unless otherwise specified, stops exposed at lavatories and similar fixtures shall be Chicago #1016ABCP chrome plated, loose key. Concealed stops shall be Chicago #1771ABCP.
- E. All vitreous china fixtures shall be Zurn, Kohler, or American Standard, except where specifically noted otherwise. All fixtures shall be standard white color, except as noted.
- F. All fixtures shall meet or exceed the requirements of the California Administrative Code, Title 24, Part 5.
- G. All plumbing fixtures providing domestic water shall comply with AB 1953, lead free. This includes, but is not limited to, lavatory faucets, sink faucets, shower valves, emergency showers, hose bibbs, and drinking fountains.

1. P-1 - WATER CLOSET

- a. Fixture: Acorn "Dura-Ware" series, model 2100-T-1-HET-FVBO, wall mounted blowout jet; 14 gage, type 304 stainless steel, seamless welded; top supply; elongated bowl, self-draining flushing rim; integral seat, 1.28 gpf (HET); See Architectural Drawings for mounting height.
- b. Flush Valve: Sloan, "Sloan 111-1.28-YO-DFB-SG"; angle stop bumper, dual-filtered fixed bypass diaphragm, single flush, "Sanigard" handle; 1.28 gpf
- c. Carrier: Zurn Z1201/Z1202 EZ Carry; 500 lb. capacity

2. P-1A - WATER CLOSET (ADA)

- a. Fixture: Acorn "Dura-Ware" series, model 2100-T-1-ADA-HET-FVBO; wall mounted blowout jet; 14 gage, type 304 stainless steel, seamless welded; top supply; elongated bowl, self-draining flushing rim; ADA compliant 18" integral seat height, 1.28 gpf (HET); See Architectural Drawings for ADA mounting height.

- b. Flush Valve: Sloan, "Sloan 111-1.28-YO-DFB-SG"; angle stop bumper, dual-filtered fixed bypass diaphragm, single flush, "Sanigard" handle; 1.28 gpf; ADA compliant
 - b. Carrier: Zurn Z-1201 or 1202, no-hub; 500 lb. capacity with auxiliary inlets as required.
3. **P-2A - LAVATORY (ADA)**
- a. Fixture: Acorn "Dura-Ware" series, model 1953LC-1-9-H24-OF-GT; 20" x 22"; ADA compliant; type 304 stainless steel; wall mounted; without valves and punched for 4" centers (2 holes); grid strainer w/ tailpiece; overflow See Architectural Drawings for ADA mounting height.
 - b. Faucet: Chicago #802-VE2805-665ABCP; deck mounted; 4" fixed centers, metering;; 0.5 gpm vandal proof non-aerating spray; 4" integral cast brass spout (HW/CW)
 - c. P-Trap: McGuire #PW2150; insulated adjustable trap with cleanout; includes covers for riser, angle stop, and tailpiece
 - d. Carrier: Zurn Z1251
4. **P-3 - URINAL**
- a. Fixture: Acorn "Dura-Ware" series, model 2158-T-1-FVBO; top supply, wall mounted; 0.125 gpf. See Architectural Drawings for mounting height.
 - b. Flush Valve: Sloan, model "Sloan" 186-0.125-DBP; exposed; dual-filtered bypass
 - c. Carrier: Zurn Z-1222
5. **P-3A - URINAL (ADA)**
- a. Fixture: Acorn "Dura-Ware" series, model 2158-T-1-FVBO; top supply, wall mounted; 0.125 gpf. See Architectural Drawings for ADA mounting height.
 - b. Flush Valve: Sloan "Royal" 186-0.125DBP or Zurn Z6003"; exposed; double bypass
 - c. Carrier: Zurn Z-1222
7. **P-4 - MOP SINK**
- b. Fixture: Florestone Model 96; neo angle; drop front mop receptor; 24" x 24" x 12"; terrazzo; stainless steel cap.
 - c. Faucet: Chicago 897-RCF; vacuum breaker; pail hook; rough chrome plated; adjustable centers.
8. **P-6 - DRINKING FOUNTAIN & BOTTLE FILLER (ADA)**
- a. Fixture: Elkay "EZH2O", #VRCTLDDWSK, ADA compliant; vandal-resistant bottle filling station, green ticker, electronic bottle filler button with mechanical front bubbler button activation, 1.5 gpm fill rate; non-filtered, non-refrigerated bi-level drinking fountain, stainless steel vandal resistant bubblers, "real drain" system; indoor/outdoor use

2.19 KITCHEN FIXTURES

- A. The quantity and location of fixtures shall be taken from the Architectural and Plumbing Drawings.

- B. All kitchen equipment shall be furnished by kitchen equipment contractor. This Contractor shall take delivery of the fixtures at the job site and shall install all fixtures. Installation shall include: setting all fixtures listed above; leveling all fixtures listed above; and attaching all sinks listed above to the wall.
- C. This Contractor shall: rough-in all plumbing required for the installation of the kitchen equipment; install all faucets and fixtures from which water is dispensed; make final plumbing connections to all kitchen fixtures scheduled for plumbing connections; install indirect wastes from fixtures to the nearest floor sink on all fixtures requiring indirect waste; install direct waste and vent connections, including P-traps, on all fixtures requiring direct waste and vent. Traps unless otherwise noted shall be 17-ga. brass tubing, chrome plated when exposed. All exposed indirect wastes shall be chrome plated copper.
- D. Stops and supplies: Provide stops for all fixtures. Unless otherwise specified, stops exposed at lavatories and similar fixtures shall be Chicago #1016ABCP chrome plated, loose key. Concealed stops shall be Chicago #1771ABCP.
- E. Submit cuts on all stops, traps, etc., furnished by this Contractor.

2.20 HOT WATER RETURN RECIRCULATION PUMP

- A. Grundfos UPS series circulating pump, as scheduled on the Drawings or approved equal.
- B. Pumps housing shall be bronze. Pumps shall have a stainless steel shaft, neck ring, impeller and bearing plate; lubricated tungsten carbide motor bearings; stator with built-in thermal overload switch; and dynamically balanced rotor.
- C. The terminal box shall have a multiple-speed switch and fiber optic indicator lights.

2.21 ELECTRIC WATER HEATER

- A. Water heater shall be A.O. Smith, "Gold Xi Commercial Electric" series, model DVE-xx, as scheduled on the Drawings or approved equal. All models shall meet NSF-5 requirements.
- B. Water heater shall have LCD display with built-in diagnostic and troubleshooting information. Water heater shall be equipped with dual extruded high-density anodes. All internal surfaces of the heater exposed to water shall be glass-lined with an alkaline borosilicate composition that has been fused to steel by firing at a temperature range of 1400°F to 1600°F.
- C. Internal power circuit fusing shall be provided. Element operation shall be linear sequencing through individual magnetic contactors. Control circuit shall be factory fused and include an immersion thermistor temperature probe with built in ECO control. Control cabinet and jacket shall be of baked enamel finish and shall provide full size control and element compartment for complete service and maintenance performance through front hinged compartment door and enclose tank with foam insulation. 1 1/4" inlet and outlet connection shall be provided.
- D. Water heater shall meet or exceeds the thermal efficiency and standby loss requirements of current edition of ASHRAE/IES 90.1.

2.22 GREASE INTERCEPTOR

- A. Schier GB-xx "Great Basin™" series polyethylene grease interceptor, where shown on the Drawings, or approved equal. 4" inlet/outlets. Sch. 40 plain end (no hub); 40 gpm. Liquid

capacity: 52 gallons; maximum grease capacity: 249 pounds; maximum solids/sediment capacity: 12.5 gallons; 2,000 pound load rated, bolted, gas/water tight com

PART 3 - EXECUTION

3.01 VIBRATION AND SOUND CONTROL

- A. Make all necessary provisions to prevent the transmission of vibration to the building structure and the passage of noise from the equipment rooms to other rooms. Provisions shall include: vibration isolators for motor driven equipment; flexible pipe connections to motor driven equipment; resilient mounting for piping; sealing off pipe and duct penetrations of walls, floors and ceilings of equipment rooms.
- B. Provide pipe and sound isolation for all piping through walls, Acoustoplumb by LSP Products, Holdrite Silencer by Hubbard Enterprises, or equal.

3.02 SURFACE CONDITIONS

- A. This Contractor shall be held to have examined the site and compared it with the Contract Documents, and to have satisfied himself as to the conditions under which the work is to be performed. In the event of discrepancy, he shall notify the Architect and proceed as he directs. He shall be held responsible for all existing conditions, whether or not accurately described, and no allowance shall subsequently be made on his behalf for any error, omission, or extra expense to which he may be put due to failure or neglect on his part to make such examination and notification.
- B. Prior to commencing the work of this Section, this Contractor shall inspect the installed work of other trades and verify that their work is sufficiently complete to permit the start of work under this Section and that the completed work will be in complete accordance with the original design. In the event of discrepancy immediately notify the Architect and proceed as he directs.

3.03 ACCESSIBILITY

- A. Equipment shall be placed and piping connections made in such a manner that all routine adjustments and maintenance operations may be carried out without inconvenience and so that all code requirements for clearances are maintained.

3.04 VIBRATION AND SOUND CONTROL

- A. Make all necessary provisions to prevent the transmission of vibration to the building structure and the passage of noise from the equipment rooms to other rooms. Provisions shall include: vibration isolators for motor driven equipment; flexible pipe connections to motor driven equipment; resilient mounting for piping; sealing off pipe and duct penetrations of walls, floors and ceilings of equipment rooms.

3.05 INSTALLATION, GENERAL

- A. Provide all necessary cutting in connection with the work of this Section. No structural members shall be drilled, bored, or notched in a manner that will impair their structural capacity; all penetrations of concrete or masonry shall be made with core drills. No cutting shall be done without the approval of the Architect.

3.06 INSULATION

- A. Insulation shall be applied in complete accordance with the manufacturer's published installation instructions. All insulation shall be applied on clean, dry surfaces and shall be continuous through wall and ceiling openings and sleeves. All joints shall be firmly butted together and longitudinal jacket laps and butt strips shall be smoothly secured. Specified adhesives, mastics, and coatings shall be applied at the manufacturer's recommended minimum coverage per gallon.

3.07 INSTALLATION, PIPING

- A. Soil, Waste, Vent, Drain Piping:
1. Soil, waste, and vent piping occurring within the building shall be installed to a uniform minimum grade of $\frac{1}{4}$ " per foot unless otherwise noted. Vent piping shall be graded so that all condensation shall flow directly to a soil or waste line.
 2. Exterior soil and waste lines shall be installed to invert or grades indicated on the drawings.
 3. Bell and Spigot pipe shall be installed with the bell up grade.
 4. Changes in direction of drainage piping shall be accomplished by the use of appropriate drainage and sanitary fittings.
 5. Drilling and tapping of drains, soil, waste, or vent pipes and the use of saddle hubs and bands are prohibited.
 6. Protection against breakage of piping passing under or through walls shall be provided using specified sleeves and caulking.
 7. Adapters shall be installed between threaded iron and soil pipe.
 8. Test tees shall be installed at the foot of all soil, waste, and storm water stacks.
 9. Cleanouts shall be located where indicated on the Drawings; at all horizontal offsets; at ends of waste or sewer branches more than 5' in length; at intervals of 100' in straight runs of piping, or at closer intervals if directed or required by local code. Location of cleanouts in finished spaces shall be approved by the Architect prior to installation.
- B. Hot, Cold Water Systems:
1. Di-electric unions shall be installed where copper pipe is connected to galvanized steel piping or stub outs.
 2. Connections from copper pipe to fixture supply fittings shall be made with copper or brass nipples.
 3. Provide 18" high vertical air chambers at all domestic water connections to fixtures and/or equipment that are not specified to have shock absorbers.
 4. All domestic water piping shall be kept clear of the building structure. Where it is within 1" of the building structure it shall be wrapped with felt (3/16" minimum thickness).
 5. To the greatest extent possible, domestic cold water piping shall be kept separated from hot piping and where there is a choice shall be run in the coolest portion of the available space.
- C. Natural Gas Piping Systems:
1. Natural gas piping shall slope back to meter where possible; bottom of vertical natural gas lines shall be fitted with 6" long capped drip legs.
 2. In addition to main shut-off valve, a natural gas stopcock shall be installed at each natural gas fired piece of equipment.
- D. Plumbing Fixtures:
1. Space between wall mounted fixtures and wall surface shall be neatly pointed up with G.E. silicone rubber compound of color matching fixture.
 2. All exposed bolt heads and nuts used to secure fixtures shall be concealed with vitreous china caps.

E. Flashing:

1. All roof and wall penetrations shall be flashed and counterflashed water tight with 26 gauge sheet metal, except as noted.
2. Vents through roof shall be flashed with Semco #1100-4 lead flashing assemblies. Flashing shall be extended over top of pipe and shall be turned down inside top of pipe.

F. Excavation, Backfill:

1. Provide all excavation, trenching, and backfill in connection with the work of this Section.
2. Excavation shall be carried to 4" below the bottom of pipes. Provide a sand bedding for all sloped drainage piping, and provide smooth uniformly graded bedding of firm but yielding material for all other piping, catch basins, and similar structures.
3. Backfill material shall be non-corrosive and free from all foreign material that could damage pipes. Installation shall be in accordance with "Earthwork" Section.

G. Indirect Waste Piping:

1. Indirect waste piping shall be installed to a uniform minimum grade of $\frac{1}{4}$ " per foot unless otherwise noted.
2. Changes in direction of indirect waste piping shall be accomplished by the use of appropriate drainage fittings.
3. Drilling and tapping of indirect waste pipes and the use of saddle hubs and bands are prohibited.
4. Protection against breakage of piping passing under or through walls shall be provided using specified sleeves and caulking.

3.08 CONNECTION, OWNER FURNISHED EQUIPMENT

- A. All electrical wiring and connections for equipment furnished under this Section shall be furnished and installed under the Electrical Sections.

3.09 TESTING, INSPECTIONS

A. General:

1. This Contractor shall not allow or cause any work of this Section to be covered or enclosed until it has been inspected, tested, and approved by the Architect and the authorities having jurisdiction over the Work. Should any of this work be enclosed or covered up before such inspection, testing, and approval, this Contractor shall uncover the work, have the necessary inspections, tests, and approvals made and, at NO expense to the Owner, make all repairs necessary to restore both his work and that of other contractors which may have been damaged to be in conformity with the Contract Documents.

B. Tests:

1. This Contractor shall make all tests required by all local, state, and federal laws, codes, ordinances, and regulations having jurisdiction over this work.
2. Furnish all necessary labor, materials, and equipment for conducting tests, and pay all expenses in connection therewith. Should leaks develop while testing, repairs shall be made, and tests shall be repeated until a satisfactory test is obtained.
3. Water Piping: Shall be hydrostatically tested for six (6) hours at 150 psi. All equipment shall be tested water tight at utility pressure.
4. Drainage and Vent Piping: Shall be tested for (1) hour by plugging all outlets and filling the pipes with water to the top of vertical sections of pipes. No loss of water shall be permitted.
5. Natural Gas Piping: Shall be tested for twenty-four (24) hours at a pressure of 50 psig with nitrogen or compressed air. NO pressure drop shall be allowed during the last four (4)

hours of the test. Tests joints of natural gas piping with Leak-Tek or Nupro-Snoop solution while maintaining ten (10) psig minimum internal pressure.

6. Compressed Air Piping Systems: Shall be tested with compressed air at 150 psig for six (6) hours. No pressure drop shall be allowed during the last four (4) hours of the test. Check for leaks with a soap solution.

3.10 CLEANING

- A. Flush all water piping systems. Remove, clean and replace all strainer baskets prior to final inspection.
- B. Blow out all compressible fluid piping with compressed air before connecting with regulators or equipment.

3.11 DOMESTIC WATER SYSTEM STERILIZATION

- A. Upon completion of this work, the new domestic water system shall be thoroughly flushed, sterilized and reflushed. Sterilization and reflushing shall be performed using the procedure below. All work shall be performed in the presence of the inspector.
- B. All domestic water outlets shall have signs posted at their location stating that the water has not been sterilized and shall not be used for human consumption. The signs shall remain until the sterilization process is complete.
- C. Procedure
 1. Introduce chlorine or a solution of sodium hypochlorite, filling the lines slowly and supplying the sterilization agent at a rate of 200 parts of chlorine per million. The entire system shall be completely filled with the solution. All valves shall be operated and ends of all branches tested for residual chlorine. Continue to inject the solution until at least 200 ppm of free chlorine is indicated.
 2. After the sterilizing agent has been applied, the system shall be isolated with the solution retained for at least 3 hours. Test for residual chlorine after retention. If less than 200 ppm is indicated, repeat the sterilization procedure.
 3. After satisfactory sterilization, flush the system until all traces of the chemical are removed or until the chlorine content is no greater than that in the existing supply.
- D. After a period of 48 hours minimum, bacteriological tests, using samples from at least 3 representative points, shall be made by recognized testing agency, who shall certify to the Architect that the system is bacteriologically safe and at least equal in safety to that of the principal water supply. The laboratory report and certification shall be transmitted to the Architect.

3.12 ADJUSTING

- A. Properly adjust all stops, and controls, and demonstrate safe and satisfactory operation of all equipment.

3.13 CLEANUP

- A. Upon completion of the work of this Section, remove all surplus material, debris, and equipment associated with or used in the performance of this work.

END OF SECTION

P-1, PL-A



Dura-Ware® 2100 Series
Blowout Jet Toilet - Off Floor

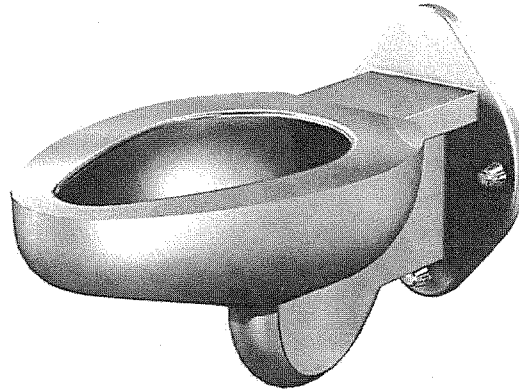

2100-W-1-CN

Fixture May Show Some Available Options

Please visit www.acorneng.com for most current specifications.

Blowout Jet Toilet - Off Floor

Fixture is arranged to be installed on finished wall from the front side. Unit is fabricated from 14 gage, type 304 stainless steel and is seamless welded construction. Exterior has a satin finish with an integral contoured seat. The inside of the toilet bowl also has a satin finish. Wall flange is reinforced for maximum strength and offered with optional 3395 Anchoring Assembly for additional support.

Toilet is Blowout Jet type with elongated bowl manufactured to comply with ASME A112.19.3 and CSA B45.4 standards. Toilet requires a minimum of 25 PSI flow pressure and uses a minimum water consumption of 1.28 GPF. Trap has a minimum 3-1/2" seal, will pass a 2-1/8" ball and is fully enclosed. Toilet has a 1-1/2" NPT flushing inlet connection and a gasketed waste outlet.

Flush Valve supply is additionally available for exposed or concealed flush valve styles in 1.28 GPF, 1.6 GPF or 3.5 GPF with 1-1/2" NPT connection.

GUIDE SPECIFICATION

Provide and install Acorn Dura-Ware Blowout Jet Toilet (specify model number and options). Toilet bowl shall be fabricated from 14 gage, type 304 stainless steel. Construction shall be seamless welded and exposed surfaces shall have a satin finish. Toilet shall be concealed blowout jet type with an elongated bowl, a self-draining flushing rim, and an integral contoured seat. Toilet shall meet ASME A112.19.3 and CSA B45.4 requirements and will flush with a minimum of 25 PSI flow pressure when used in conjunction with a minimum of 1.28 GPF. Toilet trap shall have a minimum 3-1/2" seal that shall pass a 2-1/8" diameter ball and be fully enclosed. Toilet waste outlet shall be a gasketed waste.



Dura-Ware® 2100: Blowout Jet Toilet - Off Floor

WALL THICKNESS AND TYPE (Must Specify)

Thickness: _____ Type: Concrete Block Steel

MODEL NUMBER AND OPTIONS SELECTION:

BASE MODEL NUMBER

2100 Blowout Jet Toilet

SUPPLY (Must Specify)

-T Top (Exposed)
 -W Wall (Concealed)

FIXTURE MOUNTING AND WASTE (Must Specify)

-1 Off-Floor, Wall Outlet

FLUSH VALVE GPF'S (Must Specify)

-1.28 GPF (HET)
 -1.6 GPF
 -3.5 GPF

FLUSH VALVE OPTIONS (Must Specify)

SEE ACORN DURA-WARE SUPPLEMENTARY MATERIAL FOR FLUSH VALVE COVERS AND BOXES

- FV Flush Valve, Mechanical (N/A for ADA)
- FVBO Flush Valve by Others
- FVH Flush Valve, Hydraulic (N/A for Top Supply)
- FVL Flush Valve, ADA Lever Handle (Wall Supply)
- MVCFV Time-Trol Flush Valve (N/A for Top Supply)

TOILET SEAT OPTIONS

- HPS High Polish Integral Seat
- HS-OFLC Hinged Seat, Open Front Less Cover (N/A with #2802 Flush Valve Cover)
- HS-OFWC Hinged Seat Open Front with Cover (N/A with #2802 Flush Valve Cover)
- PFS Punched for Seat by Others

TOILET OPTIONS

- 3395 Anchoring Assembly
- BL Bedpan Lugs
- FT Flood-Trol (N/A w/ Top Supply)
- FTA Flood-Trol Auto-Reset (N/A w/ Top Supply)
- FTE Flood-Trol Electronic
- FVT Flush Thru Wall Connector
- PE Plain End Waste Extended 3" Beyond Rear of Fixture
- TF Transformer, 120VAC to 24VAC (-MVCFV option)
- TSC Toilet Shipping Cover

PRODUCT OPTIONS

- ADA 18" Integral Seat Height
- BCN Blind Cap Nuts (3)
- CN Cap Nuts (3)
- EG Enviro-Glaze Color Specify: _____
Toilet Interior & Exterior
- EGE Enviro-Glaze Color Specify: _____
Toilet Exterior Only
- VAC AcornVac System

Please visit www.acorneng.com for most current specifications.

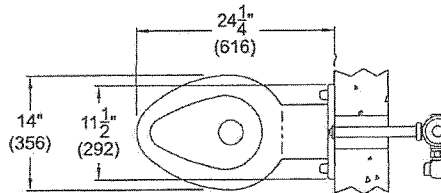
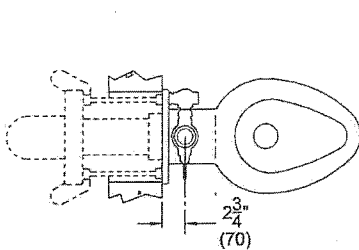

NOTES:

1. OPTIONAL -FV FLUSH VALVE FOR CONCEALED -W WALL SUPPLY
2. OPTIONAL -FV FLUSH VALVE FOR EXPOSED -T TOP SUPPLY
3. MOUNTING CARRIER (BY OTHERS)
4. OPTIONAL -CN CAP NUTS SHOWN

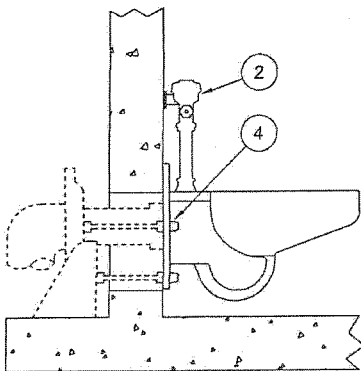

2100-T-1

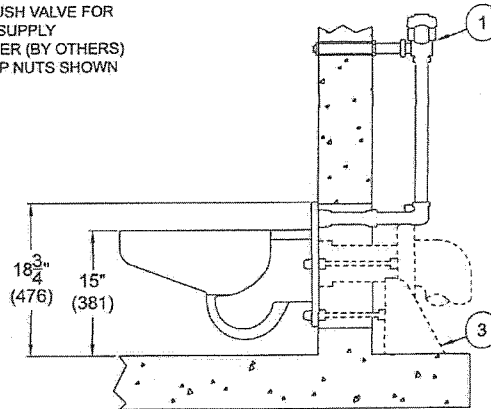

2100-W-1

WARNING: Cancer and Reproductive Harm - www.P65Warnings.ca.gov

Important: Installation instructions and current rough-in are furnished with each fixture. Do not rough in without certified dimensions. Dimensions are subject to manufacturer's tolerance of plus or minus 1/4" and change without notice. Acorn assumes no responsibility for use of void or superseded data. © Copyright 2009 Acorn Engineering Company

| | |
|--------------------------|----------------------------|
| Selection Summary | Approved for Manufacturing |
| Model No. & Option _____ | Company _____ Title _____ |
| Quantity _____ | Signature _____ Date _____ |

SLOAN.

SLOAN® MANUAL FLUSHOMETER SLOAN 111-1.28-YO-DFB-SG

CODE NUMBER

3780061

DESCRIPTION

1.28 gpf, Angle Stop Bumper, Dual-Filtered Fixed Bypass Diaphragm, Polished Chrome Finish, Single Flush, Sanigard® Handle, Sloan® Exposed Manual Flushometer.

DETAILS

- Flush Volume: 1.28 gpf (4.8 Lpf)
- Finish: Polished Chrome (CP)
- Valve: Diaphragm
- Bypass: Dual-Filtered Fixed Bypass Diaphragm (DFB)
- Valve Body Material: Semi-red Brass
- Fixture Type: Water Closet
- Fixture Connection: Top
- Rough-In Dimension: 11 1/2" (292mm)
- Spud Coupling: 1 1/2" (38mm)
- Supply Pipe: 1" (25mm)
- Handle: Sanigard® (SG)
- Bumper: Angle Stop (YO)

FEATURES

- 1" I.P.S. Screwdriver Bak-Chek® Angle Stop with Vandal Resistant Stop Cap
- Vacuum Breaker with Flush Connection
- Spud Coupling and Spud Flange for 1 1/2" Top Spud
- Sweat Solder Adapter with Cover Tube and Cast Wall Flange
- Non-Hold-Open Handle and No External Volume Adjustment to Ensure Water Conservation
- Diaphragm, Handle Packing and Vacuum Breaker Molded from PERMEX® Rubber Compound for Chloramine Resistance
- ADA Compliant Metal Oscillating Non-Hold-Open Handle

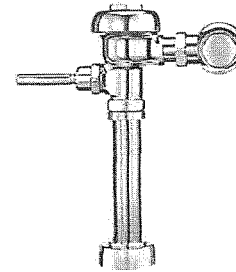

COMPLIANCES & CERTIFICATIONS



(WaterSense Listed, Satisfies LEED Credits, ADA Compliant, cUPC Certified, cUPC Green Certified, BAA Compliant)

RECOMMENDED SPECIFICATION

Valve Body, Cover, Tailpiece and Control Stop shall be in conformance with ASTM Alloy Classification for Semi-Red Brass. Valve shall be in compliance with the applicable sections of ASSE 1037 and ANSI/ASME 112.19.2.

VALVE OPERATING PRESSURE (FLOWING)

15–80 PSI (103–552 kPa). Specific fixtures may require greater minimum flowing pressure - consult manufacturer requirements.

DOWNLOADS

- Sloan Exposed Installation Instructions
- Sloan Exposed (Spanish) Installation Instructions
- Control Stop Repair and Maintenance Guide
- Flush Connections Flanges Repair and Maintenance Guide
- Tail Piece Repair and Maintenance Guide
- Sloan Flushometer Repair and Maintenance Guide
- Sloan/Regal ESS Repair and Maintenance Guide
- Additional Downloads

NOTES

All information contained within this document subject to change without notice.

Looking for other variations of the SLOAN 111 product? View the general spec sheet with all options.

Find a compatible urinal for this flushometer.
Find a compatible water closet for this flushometer.

Sloan 10500 Seymour Ave, Franklin Park, IL 60131
Phone: 800.982.5839 • Fax: 800.447.8329 • sloan.com

ROUGH-IN

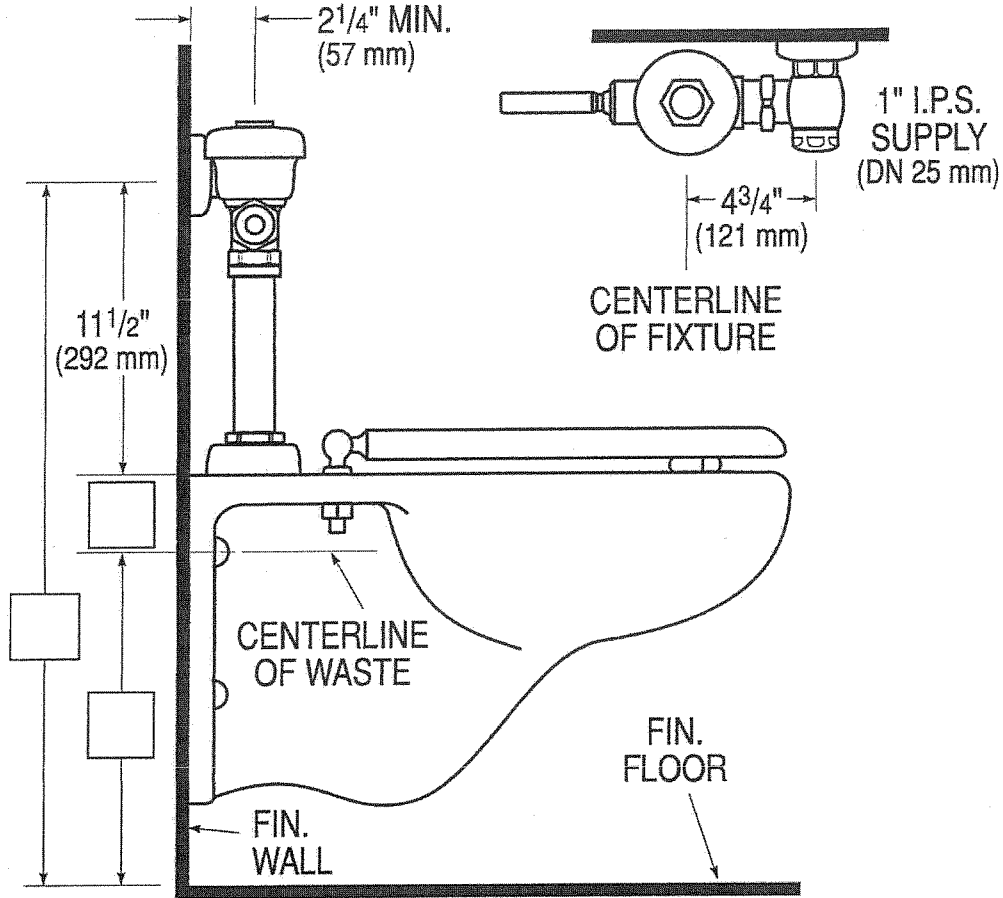

P-3, P-3A



Dura-Ware® 2158 Series
ADA Compliant High Efficiency Urinal

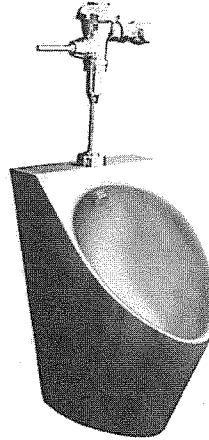

2158-T-1

Fixture May Show Some Available Options

Please visit www.acorneng.com for most current specifications.

ADA Compliant High Efficiency Urinal

Dura-Ware High Efficiency Urinals are engineered to combine attractive looks with versatility, and intended for mounting onto a finished wall from the front. Units feature a contoured interior to facilitate cleaning. Urinals mounted at 17" rim height comply with ANSI, ADA, UFAS accessibility requirements. Compliance is subject to the interpretation and requirements of the local code authority.

Fixture bowl is fabricated of 16 gage type 304 stainless steel and the housing fabricated of 18 gage type 304 stainless steel with exterior surfaces polished to a satin finish.

Urinal is a high efficiency type requiring a 1/8 GPF (0.47 Liters per Flush) to 1/2 GPF (1.8 Liters per Flush) flush valve and supplied with 3/4" NPT flushing inlet connection and stainless steel bee hive dome strainer with 1-1/2" O.D. P-Trap assembly.

Installation is Front Mount and the fixture includes an open bottom to facilitate mounting directly to a reinforced wall from within the housing.

GUIDE SPECIFICATION

Provide Acorn Dura-Ware Stainless Steel Urinal (specify model number and options). Urinal mounted at 17" rim height to comply with ANSI, ADA and UFAS accessibility requirements. Interior to have a contoured surface to facilitate cleaning. Fixture shall be fabricated of 18 gage with 16 gage bowl type 304 stainless steel with exposed surfaces polished to a satin finish.



Dura-Ware® 2158: Dura-Ware Urinal - ADA Compliant

MODEL NUMBER AND OPTIONS SELECTION

WALL THICKNESS AND TYPE

Thickness: _____ Type: Concrete Block Steel

BASE MODEL NUMBER

-2158 Dura-Ware Urinal

SUPPLY SELECTION (Must Specify)

-T Top (Exposed)
 -W Wall (Concealed)

FIXTURE MOUNTING & WASTE (Must Specify)

-1 Off-Floor, Wall Outlet

FLUSH VALVE GPF's (Must Specify)

-0.125 GPF
 -0.5 GPF

FLUSH VALVE OPTIONS (Must Specify)

Refer to Acorn Dura-Ware Supplementary for Box Cover(s) and Access Panel(s)

-FV Flush Valve, Mechanical (N/A for ADA)
 -FVBO Flush Valve By Others
 -FVH Flush Valve Hydraulic (Concealed F.V.)
 -FVL Flush Valve, ADA Lever Handle (Concealed F.V.)

PRODUCT OPTIONS (Must Specify)

-EG Enviro-Glaze (Interior and Exterior):
 Color: _____
 -HP High Polish Finish

Please visit www.acorneng.com for most current specifications.

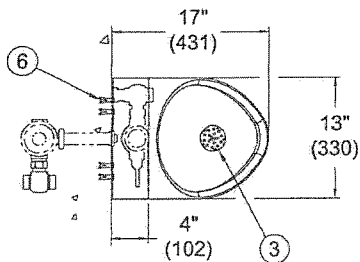

1. Flush Nozzle
2. 1-1/2" O.D. P-Trap Assembly
3. Removable Strainer Assembly
4. Optional -T Top Supply -FV Flush Valve
5. Optional -W Wall Supply -FV Flush Valve
6. Wall Mounting Anchor (By Others)
7. 3/4" NPT Flushing Inlet Connection

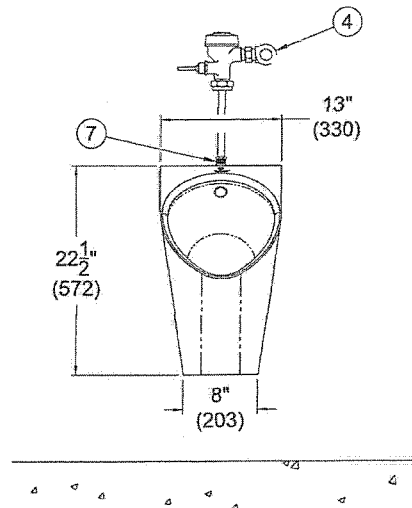
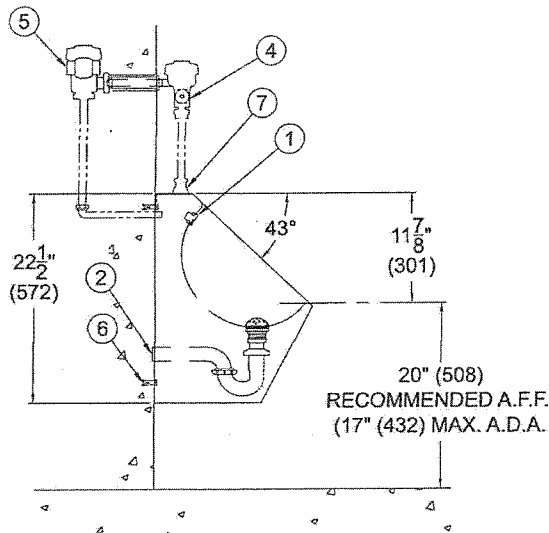

MODEL #2158-T/W-1

WARNING: Cancer and Reproductive Harm - www.P65Warnings.ca.gov

Important: Installation instructions and current rough-in are furnished with each fixture. Do not rough in without certified dimensions. Dimensions are subject to manufacturer's tolerance of plus or minus 1/4" and change without notice. Acorn assumes no responsibility for use of void or superseded data. © Copyright 2008 Acorn Engineering Company

| | |
|--|--|
| <p style="text-align: center;">Selection Summary</p> <p>Model No. & Option _____</p> <p>Quantity _____</p> | <p style="text-align: center;">Approved for Manufacturing</p> <p>Company _____ Title _____</p> <p>Signature _____ Date _____</p> |
|--|--|

CODE NUMBER

3782644

DESCRIPTION

0.125 gpf, Dual-Filtered Bypass, Polished Chrome Finish, Single Flush, Sanigard® Handle, Sloan® Exposed Manual Flushometer.

DETAILS

- Flush Volume: 0.125 gpf (0.5 Lpf)
- Finish: Polished Chrome (CP)
- Valve: Diaphragm
- Bypass: Dual-Filtered Bypass (DBP)
- Valve Body Material: Semi-red Brass
- Fixture Type: Urinal
- Fixture Connection: Top
- Rough-In Dimension: 11 ½" (292mm)
- Spud Coupling: ¾" (19mm)
- Supply Pipe: ¾" (19mm)
- Handle: Sanigard® (SG)

FEATURES

Quiet, Exposed, Diaphragm Type, Chrome Plated High Efficiency Urinal

- ¾" I.P.S. Screwdriver Bak-Chek® Angle Stop with Vandal Resistant Stop Cap
- Vacuum Breaker with Flush Connection
- Spud Coupling and Spud Flange for ¾" Top Spud
- Sweat Solder Adapter with Cover Tube and Cast Wall Flange
- Non-Hold-Open Handle and No External Volume Adjustment to Ensure Water Conservation
- High Efficiency flush accuracy
- Diaphragm, Handle Packing and Vacuum Breaker Molded from PERMEX® Rubber Compound for Chloramine Resistance
- ADA Compliant Metal Oscillating Non-Hold-Open Handle

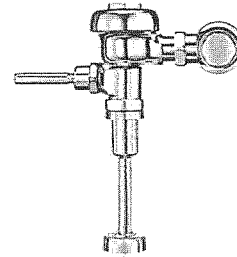

COMPLIANCES & CERTIFICATIONS



(ADA Compliant, cUPC Certified, WaterSense Listed, BAA Compliant, Satisfies LEED Credits)

RECOMMENDED SPECIFICATION

Valve Body, Cover, Tailpiece and Control Stop shall be in conformance with ASTM Alloy Classification for Semi- Red Brass. Valve shall be in compliance with the applicable sections of ASSE 1037 and ANSI/ASME 112.19.2.

VALVE OPERATING PRESSURE (FLOWING)

15–80 PSI (103–552 kPa). Specific fixtures may require greater minimum flowing pressure - consult manufacturer requirements.

DOWNLOADS

- Sloan Exposed Installation Instructions
- Sloan Exposed (Spanish) Installation Instructions
- Control Stop Repair and Maintenance Guide
- Flush Connections Flanges Repair and Maintenance Guide
- Tail Piece Repair and Maintenance Guide
- Sloan Flushometer Repair and Maintenance Guide
- Additional Downloads

NOTES

All information contained within this document subject to change without notice.

Looking for other variations of the SLOAN 186 product? View the general spec sheet with all options.

Find a compatible urinal for this flushometer.

Find a compatible water closet for this flushometer.

SLOAN.

SLOAN® MANUAL FLUSHOMETER
SLOAN 186-0.125-DBP-SG

ROUGH-IN

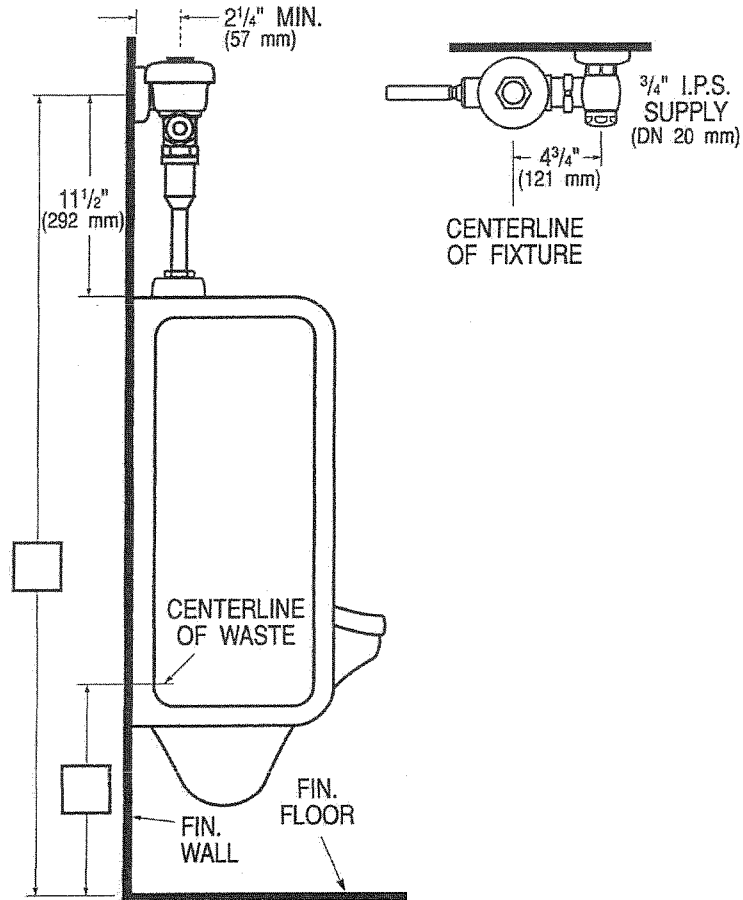

Sloan 10500 Seymour Ave, Franklin Park, IL 60131
Phone: 800.982.5839 • Fax: 800.447.8329 • sloan.com



Dura-Ware® 1953LC Series
20" Lavatory - ADA Compliant

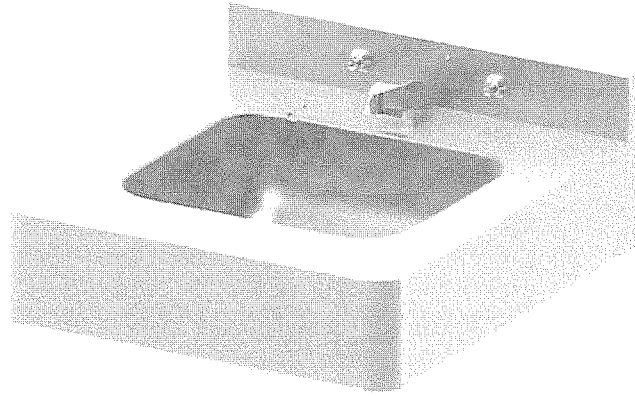

1953LC-1-DMS-04-M

Fixture May Show Some Available Options

Please visit www.acorneng.com for most current specifications.

20" Lavatory - ADA Compliant

Fixture is arranged to be installed on a finished wall from the front side utilizing a concealed arm carrier by others. Fixture is fabricated of 16 gage, type 304 stainless steel and is seamless welded construction. Exterior has a satin finish. Unit conforms with ANSI, UFAS, and ADA requirements for accessibility. Compliance is subject to the interpretation and requirements of the local code authority.

Lavatory Rectangular Bowl is 14" x 12" x 5" deep. The deck has an integral, self-draining soap dish. The lavatory includes 1-1/2" drain punching to receive optional -GE or -GT grid strainer.

Lavatory Valves (ADA compliant) available with valve and faucet/spouts that conform with lead free requirements for NSF61, Section 9 and CHSC 116875.

1. Air control pushbutton valves using atmospheric air; metering non-hold open type. Timing is from 5 to 60 seconds. Air control valves can be remotely located up to 10 feet from the operating pushbutton.
2. Electronic valve system using Modular Valve Controller for water metering through precise electronic control of a solenoid valve. Valve timing is from 1 second to 9 minutes. Modular Valve Controller can be remotely located up to 100 feet from the operating pushbutton.
3. Centerset with gooseneck spout and wrist blade handles, suffix -CSG.

GUIDE SPECIFICATION

Provide and install an Acorn Dura-Ware, 20" wide ADA Compliant Lavatory (specify model number and options). Fixture shall be fabricated from heavy gage, type 304 stainless steel. Construction shall be seamless welded with a satin finish exterior. Lavatory deck shall have an integral air-circulating, self-draining soap dish. Installer shall provide all wall mounting hardware to include concealed arm carrier. Installation shall be made in accordance with manufacturer's recommendation and details. Units to conform with ANSI, UFAS and ADA requirements for accessibility.



Dura-Ware® 1953LC : 20" Lavatory - ADA Compliant

WALL THICKNESS AND TYPE (Must Specify)

Thickness _____ Type: Concrete Block Steel

MODEL NUMBER AND OPTIONS SELECTION:

BASE MODEL NUMBER

1953LC 20" x 22" ADA Compliant Lavatory

FIXTURE MOUNTING AND WASTE (Must Specify)

-1 Off-Floor, Wall Outlet

BUBBLER OR SPOUT SELECTION (Must Specify)

-CSG Centerset with Gooseneck Spout and Wrist Blade Handles
 -DMS Deck Mounted Spout

VALVE SELECTION (Must Specify)

-03-M Air-Control, Single Temp, Metering
 -04-M Air-Control, Hot & Cold, Metering
 -9 Without Valves with -H34 Punching (Must Specify Deck Punching)
 -MVC1 Time-Trol - Single Temp
 -MVC2 Time-Trol - Hot & Cold
 -PPZ1 Programmable Piezo Button - Single Temp w/ 9VDC Plug-In Transformer
 -PPZ2 Programmable Piezo Button - Hot & Cold w/ 9VDC Plug-In Transformer

DECK PUNCHING

Must specify when indicating -09 Without Valves option; Ø1-5/16" holes provided standard.

-H1 Single Hole; On Center
 -H24 4" Centered; Two Holes
 -H34 4" Centered; Three Holes
 -H28 8" Centerset; Two Holes*
 -H38 8" Centerset; Three Holes*

* Eliminates soap dish depression when selected.

LAVATORY WASTE OPTIONS

-GE Grid Strainer w/Close Elbow 1-1/4"
 -GT Grid Strainer w/Tailpiece 1-1/4"
 -OF Lavatory Overflow
 -TPT Tubular P-Trap 1-1/4" x 1-1/2"

PRODUCT OPTIONS

-BRS Brass Body Valve
 -EE Elbow Enclosure
 -EG Enviro-Glaze Color, Specify: _____
 -FG 14 Gage Housing
 -TE Trap Enclosure
 -TF Transformer, 120VAC to 24VAC (-MVC Only)

Please visit www.acorneng.com for most current specifications.

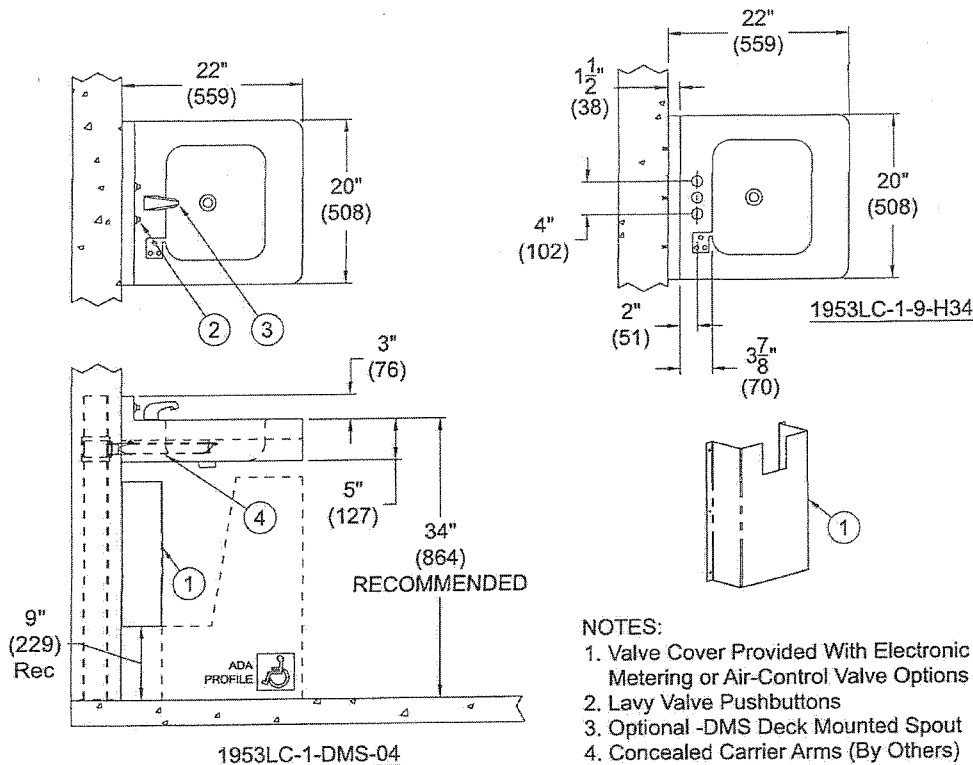

NOTES:

1. Valve Cover Provided With Electronic Metering or Air-Control Valve Options Only
2. Lavy Valve Pushbuttons
3. Optional -DMS Deck Mounted Spout
4. Concealed Carrier Arms (By Others)

WARNING: Cancer and Reproductive Harm - www.P65Warnings.ca.gov

Important: Installation instructions and current rough-in are furnished with each fixture. Do not rough in without certified dimensions. Dimensions are subject to manufacturer's tolerance of plus or minus 1/4" and change without notice. Acorn assumes no responsibility for use of void or superseded data. © Copyright 2009 Acorn Engineering Company

| | |
|---|---|
| <p style="text-align: center;">Selection Summary</p> <p>Model No. & Option _____</p> <p>Quantity _____</p> | <p style="text-align: center;">Approved for Manufacturing</p> <p>Company _____ Title _____</p> <p>Signature _____ Date _____</p> |
|---|---|

P-2A



a Geberit company

MVP FAUCETS

802-VE2805-665ABCP

Manual Faucets

Product Type

Deck Mounted 4" Fixed Centers Hot and Cold Water Metering Sink Faucet

Features & Specifications

- 4" Fixed Centers
- 0.5 GPM (1.9 L/min) Vandal Proof Non-Aerating Spray
- 1-3/4" Vandal Proof MVP Metering Push Handle
- MVP Metering Adjustable Cycle Time Closure Cartridge
- 1/2" NPSM Supply Inlets and Coupling Nut for 3/8" or 1/2" Flexible Riser
- 4" Center to Center Integral Cast Brass Spout
- ECAST® design provides durable construction with total lead content equal to or less than 0.25% by weighted average
- CFNow! Item Ships in 3 Days

Performance Specification

- Rated Operating Pressure: 20-125 PSI
- Rated Operating Temperature: 40-140°F

Warranty

- Lifetime Limited Faucet Warranty
- 5-Year Limited Cartridge Warranty
- 1-Year Limited Finish Warranty

Codes & Standards

- ASME A112.18.1/CSA B125.1
- Certified to NSF/ANSI 61, Section 9 by CSA
- California Health and Safety Code 116875 (AB1953-2006)
- Vermont Bill S.152
- NSF/ANSI 372 Low Lead Content
- ADA ANSI/ICC A117.1
- CALGreen

Job Name _____

Item Number _____

Section/Tag _____

Model Specified _____

Architect _____

Engineer _____

Contractor _____

Submitted as Shown Submitted with Variations

Date _____

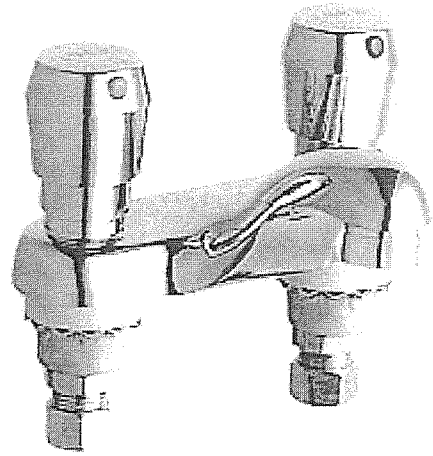

ECAST products are intended for installation where state laws and local codes mandate lead content levels or in any location where lead content is a concern.

2100 South Clearwater Drive
Des Plaines, IL
P: 847/803-5000
F: 847/803-5454
Technical: 800/TEC-TRUE
www.chicagofaucets.com



P4

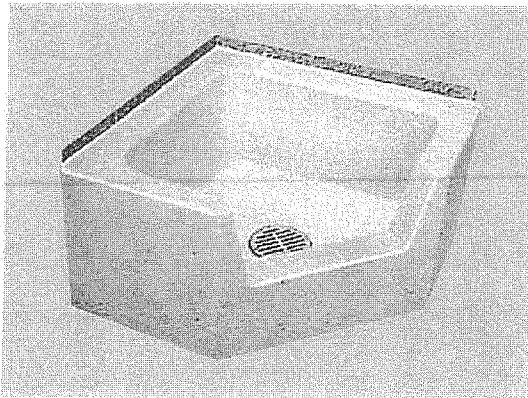

Shown: Model 95

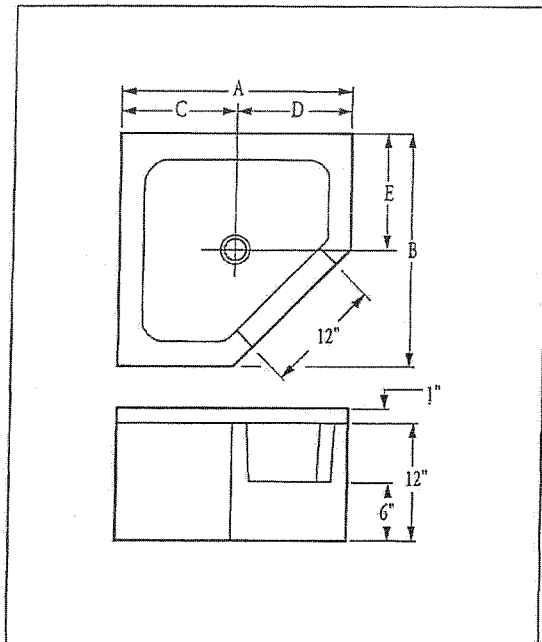
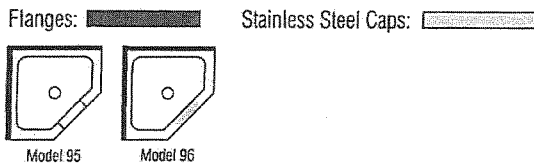

Dimensions may vary $\pm 1/4$ ". Please check unit before installation.

| Model | A | B | C | D | E | WT. |
|-------|-----|-----|-----|-----|-----|-----|
| 95 | 24" | 24" | 12" | 12" | 12" | 310 |
| 95 | 32" | 32" | 16" | 16" | 16" | 385 |
| 95 | 36" | 36" | 18" | 18" | 18" | 465 |
| 96 | 24" | 24" | 12" | 12" | 12" | 310 |
| 96 | 32" | 32" | 16" | 16" | 16" | 385 |
| 96 | 36" | 36" | 18" | 18" | 18" | 465 |

Florestone Models 95 / 96 NEO ANGLE Drop Front Terrazzo Mop Receptors

Architect's Specifications

Furnish and install neo angle drop front mop receptor as manufactured by Florestone Products Co. Shoulder shall be not less than 4" high inside and not less than 1 3/4" wide. Galvanized, bonderized steel flange will be cast integral and extend at least one inch above shoulder on two sides for corner installation against stud wall. Stainless steel protective cap to be cast integral on drop front (Model 96 only). Drain body shall be brass, cast integral and shall provide for a non-caulked connection (lead caulked optional) not less than one inch deep to a two or three inch pipe (specify 2" or 3"). Mop sinks with 3" drains are supplied with a Wedge-Lok® seal for use on ABS pipe only. Receptor shall be manufactured of tan and white marble chips cast in white portland cement to produce a compressive strength of not less than 3000 PSI, seven days after casting. Terrazzo surface shall be ground and polished with all air holes and/or pits to be grouted and excess removed and sealed to resist stains and moisture. Receptor will be reinforced with 16 gauge wire.

Note: Terrazzo is not designed to be used with anything that is over 130 degrees Fahrenheit.

Note:
Specify 2" or 3" drain size (3" standard).
Specify Model Number and size.

 **FLORESTONE**
A Spec Above.

FLORESTONE PRODUCTS CO., INC.

2851 Falcon Drive • Madera, CA 93637

T. 559.661.4171 • T. 800.446.8827

F. 559.661.2070 • florestone.com

Models 95/96

P.4

MECHANICAL FAUCETS

897-RCF

Manual Faucets



a Gerberit company

Product Type

Wall Mounted 8" Body, Adjustable Arms 7-5/8" - 8-3/8" Hot and Cold Water Sink Faucet

Features & Specifications

- 8" Body, Adjustable Arms 7-5/8" - 8-3/8"
- 2-3/8" Vandal Proof Lever Handle
- Ceramic 1/4 Turn Operating Cartridge
- 1/2" NPT Adjustable Female Union Nut Supply Arms
- 3/4" Male Hose Thread Outlet
- Round Wall Escutcheons
- Integral Stop Valves for Servicing the product
- Atmospheric Vacuum Breaker, Not Intended for Continuous Pressure Applications
- Vacuum Breaker Spout with Pail Hook and Wall Brace
- Atmospheric Vacuum Breaker, Not Intended for Continuous Pressure Applications
- CFNow! Item Ships in 3 Days

Performance Specification

- Rated Operating Pressure: 20-125 PSI
- Rated Operating Temperature: 40-140°F

Warranty

- Lifetime Limited Faucet Warranty
- 5-Year Limited Cartridge Warranty
- 1-Year Limited Finish Warranty

Codes & Standards

- ASME A112.18.1/CSA B125.1
- ADA ANSI/ICC A117.1

Job Name _____

Item Number _____

Section/Tag _____

Model Specified _____

Architect _____

Engineer _____

Contractor _____

Submitted as Shown Submitted with Variations

Date _____

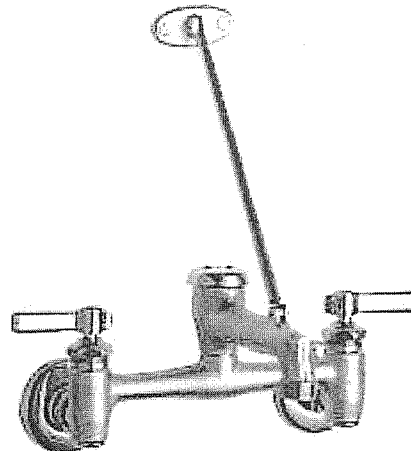

2100 South Clearwater Drive
 Des Plaines, IL
 P: 847/803-5000
 F: 847/803-5454
 Technical: 800/TEC-TRUE
 www.chicagofaucets.com

P-6

ELKAY[®] SPECIFICATIONS

Elkay EZH2O Vandal-Resistant Bottle Filling Station & Bi-Level Cooler Non-Filtered Non-Refrigerated Stainless Model VRCTLDDWSK

PRODUCT SPECIFICATIONS

Elkay EZH2O[®] Vandal-Resistant Bottle Filling Station, & Bi-Level Cooler, Non-Filtered Non-Refrigerated Stainless. Features shall include Green Ticker[™], Laminar Flow, Real Drain, Vandal-Resistant. Furnished with Vandal-Resistant bubbler. Electronic Bottle Filler Button With Mechanical Front Bubbler Button activation. Product shall be Wall Mount (On-Wall), for Indoor/Outdoor applications, serving 2 station(s). Unit shall be certified to UL 399 and CAN/CSA C22.2 No. 120. Unit shall be lead-free design which is certified to NSF/ANSI 61 & 372 (lead free) and meets Federal and State low-lead requirements.

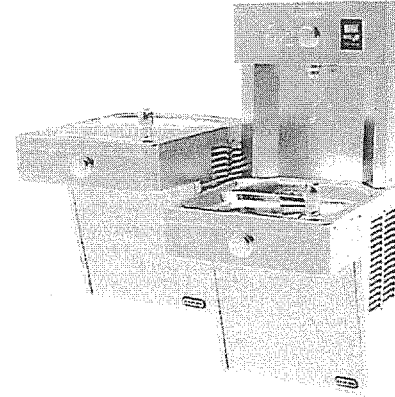

| | |
|--------------------------|--|
| Special Features: | Green Ticker [™] , Laminar Flow, Real Drain, Vandal-Resistant |
| Finish: | Stainless Steel |
| Power: | 115V/60Hz |
| Bubbler Style: | Vandal-Resistant |
| Activation by: | Electronic Bottle Filler Button With Mechanical Front Bubbler Button |
| Mounting Type: | Wall Mount (On-Wall) |
| Chilling Option: | Non-Refrigerated |
| Full Load Amps | 1 |
| Rated Watts: | 15 |
| Dimensions (L x W x H): | 36-1/8" x 18-5/8" x 38-13/16" |
| Approx. Shipping Weight: | 112 lbs. |
| Installation Location: | Indoor/Outdoor |
| No. of Stations Served: | 2 |

- Mechanically-Activated bubbler continues to supply water in event of service disruptions.
- Green Ticker: Informs user of number of 20 oz. plastic water bottles saved from waste.
- Laminar flow provides clean fill with minimal splash.
- Real Drain System eliminates standing water.
- Vandal-resistant, bubblers are one-piece, chrome plated with integral hood guard design to prevent contamination from other users, airborne deposits and tampering.

AMERICAN PRIDE. A LIFETIME TRADITION.

Like your family, the Elkay family has values and traditions that endure. For almost a century, Elkay has been a family-owned and operated company, providing thousands of jobs that support our families and communities.



Included with Product: Water Cooler (VRCTLDDWSC),
Bottle Filler (VRCWS)

PRODUCT COMPLIANCE

ADA

Buy American Act

CAN/CSA C22.2 No. 120

GreenSpec[®]

NSF/ANSI 61 & 372 (lead free)

UL 399



[Installation Instructions \(PDF\)](#)

Electrical components and water system are warranted for 12 months from date of installation. **Warranty pertains to drinking water applications only. Non-drinking water applications are not covered under warranty.**

[Warranty \(PDF\)](#)

OPTIONAL ACCESSORIES

| |
|--|
| EW3000 - WaterSentry [®] Plus Filter System Kit (Bottle Fillers) |
| 98324C - Accessory - Cane Apron for HAC, HVR, EMABF & VRC Models (Stainless) |
| 36292C - Accessory - Power Block |

PART: _____ QTY: _____

PROJECT: _____

CONTACT: _____

DATE: _____

NOTES: _____

APPROVAL: _____

In keeping with our policy of continuing product improvement, Elkay reserves the right to change product specifications without notice. Please visit elkay.com for the most current version of Elkay product specification sheets. This specification describes an Elkay product with design, quality, and functional benefits to the user. When making a comparison of other producers' offerings, be certain these features are not overlooked.

Add

WH-1



COMMERCIAL ELECTRIC WATER HEATERS

GOLD Xi SERIES COMMERCIAL ELECTRIC WATER HEATER

Designed for use as a recovery heater having its own storage tank or booster for supplying sanitizing rinse water for dish washing.

FEATURES

- Meets the thermal efficiency and or standby loss requirements of the U.S. Department of Energy and current edition of ASHRAE/IES 90.1.

ADVANCED ELECTRONIC CONTROL

- Plain English text and animated icons display detailed operational and diagnostic information. Fault or Alert messages appear if an operational issue occurs.
- Immersion temperature control adjustable through a range of 90°F to 190°F.

BMS

- BACnet and Modbus compatible using optional BMS Gateway module. Call 888-928-3702 for information.

ECONOMY MODE OPERATION

- Control system automatically lowers the Operating Set Point by a programmed value during user-defined time periods. Helps reduce operating costs during unoccupied or off-peak demand periods.

LINEAR SEQUENCING

- Banks of heating elements (3 elements per bank) are energized according to adjustable (1 to 20°F) differential set points for each bank. First bank on is the last bank off. Helps reduce current surge and provides accurate water temperature control.

INCOLOY ELEMENTS

- All models come standard with heavy duty incoloy elements.

GLASS-LINED TANK

- Three sizes; 50, 80 and 119 gallon capacity. Tank interior is coated with glass specially developed by A. O. Smith for water heater use. Foam insulation reduces costly heat loss. ASME (optional) maximum working pressure is 160 psi.

POWER CIRCUIT FUSING

- Protects elements and contactors from short circuits, overloading or line surges. Meets National Electric Code requirements (fusing required when current draw exceeds 48 amps).

STANDARD VOLTAGES

- 208, 240 and 480V single-phase and three phase delta. Convertible from three-phase to single-phase (in field) and vice versa (except 208/54 kW). 277V single-phase also available.

TERMINAL BLOCK

- Factory installed. Allows for easy service connection to block.

MAGNETIC CONTACTORS

- Heavy duty; UL rated 100,000 cycles.

THREE YEAR LIMITED TANK WARRANTY

- For complete warranty information, consult written warranty or go to hotwater.com.

OTHER STANDARD FEATURES

- Immersion style thermostats
- Simplified circuitry, color coded for ease of service. Hinged control compartment door for quick, easy access
- Two anode rods for maximum corrosion protection
- Cabinet has bonderized undercoat with baked enamel finish
- Top outlet, side inlet and relief valve openings. Nipple and brass drain valve
- CSA certified and ASME rated T&P relief valve.

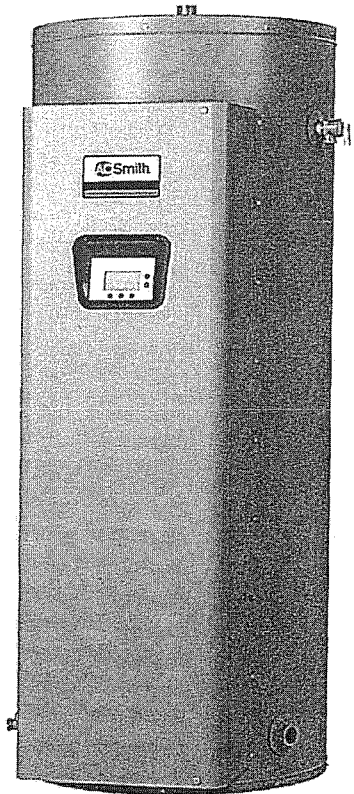

MODELS DVE-52, 80, 120



OPTIONAL



COMMERCIAL ELECTRIC WATER HEATERS

OPTIONS:

- ASME 160 psi (1103 kPa) tank construction.
- UL Listed conversion kits to adjust voltage and kW requirement in the field before and after installation.
- Manifold kits for multiple tank installations. Two heaters -part # 100109231, three heaters- part # 100109232 and four heaters- part # 100109233.
- International voltages – 220, 380, 400, 415, 575, and 600 volts, three phase available with Y connected elements.

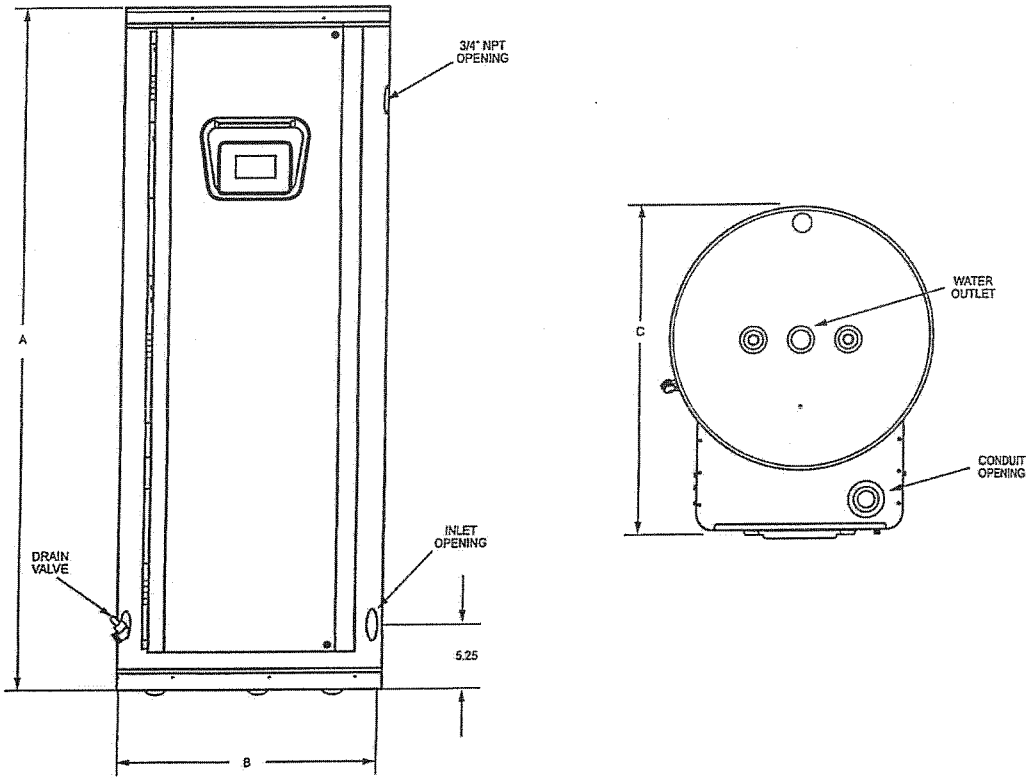

ROUGH-IN DIMENSIONS

| Model Number | Tank Capacity | | Dimensions | | | | | | Inlet/Outlet (NPT) | Approx. Shipping Weight | |
|--------------|---------------|-------|------------|-------|--------|------|--------|------|--------------------|-------------------------|-----|
| | | | A | | B | | C | | | | |
| | gal. | litre | Inches | cm | Inches | cm | Inches | cm | Inches | lbs | kG |
| DVE-52 | 50 | 189 | 55-3/4 | 142 | 21-3/4 | 55.2 | 27 | 68.6 | 1-1/4 | 265 | 120 |
| DVE-80 | 80 | 302 | 60-1/4 | 153 | 25-1/2 | 64.8 | 31 | 78.7 | 1-1/4 | 280 | 127 |
| DVE-120 | 119 | 450 | 62-1/4 | 158.1 | 29-1/2 | 75 | 35 | 88.9 | 1-1/4 | 390 | 177 |

For ASME construction add "A" to the model number (example: DVE-52A 24).

SECTION 22 1100

SITE WATER DISTRIBUTION

PART 1 - GENERAL

1.1 RELATED DOCUMENTS

- A. Drawings and general provisions of the Contract, including General and Supplementary Conditions and Division 1 Specification Sections, apply to this Section.

1.2 SUMMARY

- A. This Section includes site distribution piping outside buildings for water service, and the following components:
 - 1. Valves.
 - 2. Concrete thrust blocks.
 - 3. Cathodic Protection.
- B. Related Sections include:
 - 1. Section 31 2333 "Trenching and Backfill" for trenching and backfilling for underground water lines, and detectable warning tapes.
 - 2. Section 32 8000 "Irrigation System" for irrigation lines.
 - 3. Section for water lines within and below buildings.
 - 4. Section 13 4713 "Cathodic Protection Systems."

1.3 DEFINITIONS

- A. Water Main: Utility's water piping.
- B. Water Service: Site domestic water piping.
- C. Point of Delivery: Piping outlet from water meter.
- D. DN: Dimension Nominal.
- E. NPS: Nominal Pipe Size.
- F. PE: Polyethylene Pressure Pipe
- G. PVC: Polyvinyl chloride plastic

1.4 SUBMITTALS

- A. Product Data: For each type of product, including the following:
 - 1. Piping and related specialties.
 - 2. Cathodic Protection Design.
- B. Shop Drawings: For the following:
 - 1. Precast concrete utility boxes, including frames and covers.
 - 2. Protective enclosure for backflow preventer.
 - 3. Cathodic Protection Design.
- C. Coordination Drawings: For piping and specialties including relationship to other services in same area. Show piping and specialty sizes and valves, meter and specialty locations, and elevations.
- D. Field Quality-Control Test Reports: From Contractor.
- E. Operation and Maintenance Data: For specialties to include in emergency, operation, and maintenance manuals. In addition to items specified in Division 1 Sections for closeout procedures and operation and maintenance data, include the following:
 - 1. Valves.
 - 2. Backflow preventers.
 - 3. Protective enclosures.
 - 4. Cathodic Protection.
- F. Record drawings of installed water service lines and appurtenances in accordance with Division 1 Section for project closeout requirements.
 - 1. Locate and dimension work with reference to permanent landmarks. Indicate materials and sizes of all components.

1.5 QUALITY ASSURANCE

- A. Product Options: Drawings indicate size, profiles, and dimensional requirements of piping and specialties and are based on the specific system indicated. Refer to Division 1 Section for product requirements.
- B. Regulatory Requirements:
 - 1. Comply with requirements of the City of Brentwood. Include tapping of water mains and backflow prevention.
 - 2. Comply with standards of the City of Brentwood for potable-water-service piping, including materials, installation, testing, and disinfection.

- C. Piping materials shall bear label, stamp, or other markings of specified testing agency.
- D. NSF Compliance:
 - 1. Comply with NSF 14 for plastic potable-water-service piping.
 - 2. Comply with NSF 61 for materials for water-service piping and specialties for domestic water.
- E. Cathodic Protection System Design:
 - 1. Cathodic protection system design will be performed and stamped by a qualified Corrosion Engineer. This person shall be responsible for the design, supervision, inspection and testing of the cathodic protection system.
 - 2. Qualifications of the Corrosion Engineer shall be submitted to the owner for approval prior to commencement of work.

1.6 DELIVERY, STORAGE, AND HANDLING

- A. Preparation for Transport: Prepare valves according to the following:
 - 1. Ensure that valves are dry and internally protected against rust and corrosion.
 - 2. Protect valves against damage to threaded ends and flange faces.
 - 3. Set valves in best position for handling. Set valves closed to prevent rattling.
- B. During Storage: Use precautions for valves, according to the following:
 - 1. Do not remove end protectors unless necessary for inspection; then reinstall for storage.
 - 2. Protect from weather. Store indoors and maintain temperature higher than ambient dew-point temperature. Support off ground or pavement in watertight enclosures when outdoor storage is necessary.
- C. Handling: Use sling to handle valves if size requires handling by crane or lift. Rig valves to avoid damage to exposed parts. Do not use handwheels or stems as lifting or rigging points.
- D. Deliver piping with factory-applied end caps. Maintain end caps through shipping, storage, and handling to prevent pipe-end damage and to prevent entrance of dirt, debris, and moisture.
- E. Protect stored piping from moisture and dirt. Elevate above grade. Do not exceed structural capacity of floor when storing inside.
- F. Protect flanges, fittings, and specialties from moisture and dirt.

- G. Store plastic piping protected from direct sunlight. Support to prevent sagging and bending.

1.7 PROJECT CONDITIONS

- A. Do not interrupt existing utilities serving facilities occupied by Owner or others unless permitted under the following conditions and then only after arranging to provide temporary utility services according to requirements indicated:
 - 1. Notify Architect not less than five working days in advance of proposed utility interruptions.
 - 2. Do not proceed with utility interruptions without Architect's written permission.
- B. Information shown regarding locations of existing utilities is based upon available records and data, but shall be regarded as approximate, only. Make minor deviations necessary to conform to actual locations and conditions without extra cost. Verify location and elevation of utilities prior to commencement of excavation.
 - 1. Exercise extreme care in excavating near existing utilities. Locations of existing utilities are approximate. It is the contractor's responsibility to verify the location and depth with the appropriate agencies prior to construction.
Contractor is responsible for damage to existing utilities.

1.8 COORDINATION

- A. Coordinate connection to water main with City of Brentwood.
- B. Coordinate installation of required supporting devices and set sleeves in poured-in-place concrete and other structural components as they are constructed.
- C. Coordinate placement of valve boxes with layout of paving joints and patterns. Refer to Drawings for layout.
- D. Coordinate crossings with other underground utilities.
- E. Coordinate with locations of building connections.

PART 2 - PRODUCTS

2.1 PIPING MATERIAL

- A. Refer to Part 3 "Piping Applications" Article for applications of pipe, fitting, and joining materials.

2.2 PE PIPE AND FITTINGS

- A. Polyethylene Pressure Pipe (PE) shall be furnished in the sizes and grades designated on the plans. All pipe between the size of ¾" and 2" shall be C-901 pipe shall meet the requirements of SDR 7.
- B. Joints and Fittings: All pipes shall be suitable for use as a pressure conduit.
 - 1. Provisions shall be made for expansion and contraction at each joint with an "O" ring elastomeric gasket seal meeting requirements of ASTM D1869 and F477.
 - 2. Solvent welded joints are prohibited.
 - 3. Bell sections shall be designed to be at least as strong as the pipe wall.
 - 4. All fittings for PVC pipe shall be polyethylene encased cast iron only.
 - 5. All mechanical joints on fire service lines and fire sprinkler laterals shall be coated and wrapped.

2.3 PVC PIPE AND FITTINGS

- A. Polyvinyl Chloride Pipe (PVC) shall be furnished in the classes, sizes and grades designated on the plans. All Class 150 pipe shall meet the requirements of DR 18 and Class 200 pipe shall meet the requirements of DR 14 with cast iron O.D.
 - 1. Pipe Sizes 8-in. Diameter and Smaller:
 - (a) Polyvinyl Chloride (PVC) per requirements of ANSI/AWWA C900.
 - (b) Pipe shall be Class 150 for main and fire hydrant lines and class 200 for fire service lines.
- B. Joints and Fittings: All pipes shall be suitable for use as a pressure conduit.
 - 1. Provisions shall be made for expansion and contraction at each joint with an "O" ring elastomeric gasket seal meeting requirements of ASTM D1869 and F477.
 - 2. Solvent welded joints are prohibited.
 - 3. Bell sections shall be designed to be at least as strong as the pipe wall.
 - 4. All fittings for PVC pipe shall be polyethylene encased cast iron only.
 - 5. All mechanical joints on fire service lines and fire sprinkler laterals shall be coated and wrapped.

2.4 JOINING MATERIALS

- A. AWWA Transition Couplings:
 - 1. Manufacturers: Subject to compliance with requirements, provide products by one of the following:

- (a) Cascade Waterworks Manufacturing Company.
 - (b) Dresser Industries, Inc.; DMD Division.
 - (c) JCM Industries.
 - (d) Viking Johnson.
 - (e) Manufacturer of equal products in accordance with Division 1 requirements for product substitutions.
- B. Pipe Flange Gasket Materials: Suitable for chemical and thermal conditions of piping system contents.
- 1. AWWA C110, rubber, flat face, 1/8-inch thick, unless otherwise indicated; and full-face or ring type, unless otherwise indicated.
- C. Flange Bolts and Nuts: ASME B18.2.1, carbon steel, unless otherwise indicated.
- D. Plastic Pipe Flange Gasket, Bolts, and Nuts: Type and material recommended by piping system manufacturer, unless otherwise indicated.

2.5 GATE VALVES

- E. Gate Valves:
- 1. Gates Valves for 4-in through 8-in diameter pipe.
 - (a) Use resilient seated gate valves per AWWA C509.
 - (b) Valve ends shall be mechanical joint or flanged per AWWA C500 unless otherwise specified.
 - (c) Valves for use with flanged pipe shall be cast with Class 125 flanges, dimensions and drilling shall be per ASA B16.1. Flange bolt holes shall be spot faced if flange fillets interfere with bolt heads and nuts.
 - (d) The inlet flange for tapping gate valves shall be provided with Class 125 flange for attaching to tapping sleeve. The flange shall have a machined projection compatible with a machined recess in the tapping sleeve. The outlet of the valve shall be provided with a flange for tapping machine mounting. Tapping sleeve shall be mechanical joint and flange unless deviation is permitted by the engineer.
 - (e) All stem seals for gate valves shall be "O" rings only.
 - (f) Wrench nuts shall be made of top grade cast iron, fitting the top of the valve stem and secured by nut or key. Wrench nuts shall be 1-15/16-in. square at the top and 2-in. square at the bottom.

- (g) Valves requiring operating wrench exceeding 60 inches in length shall have extensions and guides installed in valve boxes.
 - (h) The open direction shall be left (counterclockwise) and the closed direction right (clockwise).
2. Manufacturers: Subject to compliance with requirements, provide products by one of the following:
- (a) Crane Co.; Crane Valve Group; Stockham Division.
 - (b) NIBCO INC.
 - (c) Manufacturer of equal products in accordance with Division 1 requirements for product substitutions.
3. Non-rising Stem Gate Valves:
- (a) Description: Class 125, Type 1, bronze with solid wedge, threaded ends, and malleable-iron handwheel.
 - (1) Standard: MSS SP-80.

2.6 VALVE ACCESSORIES AND SPECIALTIES

F. Valve Boxes

- 1. All valve boxes shall conform to City of Brentwood Detail No. W-13.
- 2. Lids shall have machined seating surfaces.
- 3. Valve box risers shall be manufactured for the valve box supplied. Riser to be one continuous piece and centered on valve. Should be riser or 8-in. \varnothing , Class 100 PVC.

B. Bolts, Nuts & Washers.

- 1. Bolts and nuts for flanges and fittings shall be Stainless Steel (SS) 304 or 316 per ASTM A320, alloy steel and stainless steel bolting materials for low temperature service.
- 2. Washers shall be Stainless Steel 304 or 316 to match their adjoining bolts and nuts.

C. Gaskets

- 1. Gaskets for flanged joints shall be 1/16-in. thick cloth inserted rubber per applicable parts of ANSI B16.12, AWWA C115 and AWWA C207.
- 2. Gasket material shall be free from corrosive alkali or acid ingredients and suitable for use in potable water lines.

3. Gaskets shall be one piece, full face, with holes to accommodate bolts.
 4. Gaskets for push-on joints shall be oil resistant per AWWA C111. Lubricant for push-on joints piping shall be pipe manufacturer's standard.
- D. Thrust Blocks
1. All thrust blocks for water lines shall conform to City of Brentwood Detail No. W-15.
 2. Thrust blocks shall be included at all water mains and fire services where changes in direction occur.

2.7 MISCELLANEOUS MATERIALS

- A. Portland Cement Concrete: Minimum compressive strength of 3000 psi, minimum of four sacks of cement per cubic yard of concrete, one-Inch maximum aggregate size, three-inch maximum slump, two to four percent entrained air.
1. Cement: ASTM C 150, Type I.
 2. Fine Aggregate: ASTM C 33, sand.
 3. Coarse Aggregate: ASTM C33, crushed gravel.
 4. Water: Potable.

2.8 CATHODIC PROTECTION

- A. See Section 13 4713 "Cathodic protection Systems."
- B. Materials and workmanship shall be in accordance with all applicable state and local codes. Corrosion protection shall be installed in accordance with manufacturer's instructions.
- C. All ferrous metal fittings shall be coated and wrapped for cathodic protection in accordance with Corrosion Engineer recommendations and Owner requirements.

PART 3 - EXECUTION

3.1 EXCAVATION AND BACKFILL

- A. Refer to Section 31 2000 "Earthwork" for excavation, trenching and backfilling.

3.2 PIPING APPLICATIONS

- A. General: Use pipe, fittings, and joining methods for piping systems according to the following applications.
- B. Transition couplings and special fittings with pressure ratings at least equal to piping pressure rating may be used in applications below, unless otherwise indicated.

- C. Do not use flanges, unions, or keyed couplings for underground piping.
- D. Flanges, unions, keyed couplings, and special fittings may be used, instead of joints indicated, on piping in utility boxes and vaults.
- E. Underground Water Service Piping: Use the following piping materials for each size range:
 - 1. NPS 3/4 to NPS 1-1/2 (DN 20 to DN 40): PVC (IPS); PVC socket fittings and solvent-cemented joints.
 - 2. NPS 2 to NPS 3 (DN 50 to DN 80): PVC (IPS); PVC gasketed fittings.
 - 3. NPS 4 and Larger: PVC, AWWA Class 150 pipe; PVC, AWWA Class 150 molded fittings; and gasketed joints.
- F. Aboveground Water Service Piping: Ductile iron pipe with grooved ends; ductile iron, grooved end fittings; ductile iron keyed couplings; and grooved joints.

3.3 VALVE APPLICATIONS

- A. General Application: Use threaded or flanged end valves for underground installation, as suitable for piping in which valve is installed. Install AWWA, cast-iron, non-rising stem, resilient-seated gate valves with valve box.

3.4 PIPING INSTALLATION

- A. Drawing plans, schematics, and diagrams indicate general location and arrangement of water-service piping systems. Indicated locations and arrangements were used to size pipe and calculate friction loss, expansion, and other design considerations. Install piping as indicated unless deviations to layout are approved on Coordination Drawings.
- B. Water-Main Connection: Arrange with City of Brentwood for all connections to the water main.
- C. Install ductile iron, water-service piping according to AWWA C600 and AWWA C105.
- D. Select system components with pressure rating equal to or greater than system operating pressure.
- E. Remove scale, slag, dirt, and debris from inside and outside of pipe and fittings before assembly.
- F. Install piping to permit valve servicing.
- G. Install water service piping free of sags and bends.
- H. Install fittings and thrust blocks for changes in direction and branch connections.
- I. Install sleeves for pipes passing through concrete and masonry walls and foundations.

- J. Unless indicated otherwise, bury piping with depth of cover over top at least 36 inches.
 - 1. In Loose Gravelly Soil and Rock: With at least 12 inches additional cover.
- K. Install piping by tunneling, jacking, or combination of both, under streets and other obstructions that cannot be disturbed.
- L. Restrained Joints: Install concrete thrust blocks per NFPA 24 at all horizontal and vertical changes in direction.
 - 1. Install concrete thrust blocks at all pipe tees, wyes, bends, crosses, elbows, and risers (valves).
 - 2. Thrust blocks to bear against undisturbed soil, and sized as indicated.
 - 3. Place thrust blocks so that pipe joints are accessible for inspection and repair.
- M. Install water-supply piping with shutoff valve in water supply to each building. Use gate valve and valve box.

3.5 JOINT CONSTRUCTION

- A. Make pipe joints according to the following:
 - 1. Ductile-Iron Piping, Gasketed Joints for Water-Service Piping: ANSI A21.11 (AWWA C111).
 - 2. PVC Piping Gasketed Joints: Use joining materials according to AWWA C900. Construct joints with elastomeric seals and lubricant according to ASTM D 1869 and F477 and pipe manufacturer's written instructions.
 - (a) PVC Piping Solvent-Cement Joints: Solvent Joints are prohibited.
 - 3. Dissimilar Materials Piping Joints: Use adapters compatible with both piping materials, with OD, and with system working pressure.

3.6 VALVE INSTALLATION

- A. All valves within public right-of-way shall conform to City of Brentwood Detail No. W-13 as shown on the plans.
- B. AWWA Gate Valves: Comply with AWWA C509. Install each underground valve with stem pointing up and with valve box.
- C. Center valve box on valve, setting plumb and level.
 - 1. Install valve box extensions as required to extend down to level of piping.
 - 2. Compact soil backfill around valve box to a distance of 4 feet on all sides.

3.7 CONNECTIONS

- A. Connect water service piping at water supply source and extend to point of connection to building water piping systems at 5 feet outside face of building wall in locations and pipe sizes indicated.
 - 1. Terminate water service piping at 5 feet to building wall until building water piping systems are installed. Terminate piping with caps, plugs, or flanges as required for piping material. Make connections to building water piping systems when those systems are installed.
 - 2. Refer to Division 15 Section for potable-water piping below and within buildings.
- B. Connections to Valves and Equipment: Except as otherwise indicated, make piping connections as follows:
 - 1. Install unions adjacent to each valve and at final connection to each piece of equipment having threaded pipe connection.
 - 2. Install flanges adjacent to each valve and at final connection to each piece of equipment having flanged pipe connection.

3.8 IDENTIFICATION

- A. All non-metallic water mains shall have a No. 10 gauge solid, coated, copper wire laid along the pipe, accessible in each valve box or other access opening to the system. Wire splices shall be field soldered.

3.9 PROTECTIVE ENCLOSURE INSTALLATION

- A. Install concrete slab base level and with top approximately two inches above grade.
- B. Install protective enclosure over valves and equipment.
- C. Anchor protective enclosure to concrete base.

3.10 CATHODIC PROTECTION

- A. See Section "Cathodic Protection Systems."
- B. All buried ductile iron pipes, steel or ductile iron connection fittings, and metal valves shall be corrosion protected in accordance with the recommendations provided by the Corrosion Engineer.
- C. Corrosion protection shall be installed in accordance with manufacturer's instructions.

3.11 FIELD QUALITY CONTROL

- A. Water Main Disinfection: Refer to Refer to City of Brentwood Standard Specification Section 130-1.03B1 "Testing" and Section 130-1.03C "Disinfecting Water Mains" for cleaning procedures and requirements.
- B. Prepare reports of testing activities.

3.12 CLEANING

- A. Water Main Disinfection: Refer to City of Brentwood Standard Specification Section 130-1.03C "Disinfecting Water Mains" for cleaning procedures and requirements.
- B. Prepare reports of testing activities.

END OF SECTION 22 1100

SECTION 23 0000

HEATING, VENTILATING, AIR CONDITIONING

PART 1 GENERAL

1.01 SUMMARY

- A. The requirements of the General Conditions, Supplemental General Conditions, Division 01 Sections and Section 23 0500 - General Mechanical apply to all work herein.
- B. Section includes
 - 1. Furnishing and installation of complete "Heating, Ventilating, Air Conditioning" systems, including but not necessarily limited to the following:
 - a. Ducted split system heat pumps;
 - b. Ductless split system heat pump units;
 - c. Ceiling and inline mounted exhaust fans;
 - d. Thermal and sound insulation for all piping and ductwork supplied under this Section;
 - e. Refrigerant piping and appurtenances;
 - f. Condensate drainage piping, inclusive of all pipe, fittings, anchors, support and bracing.
 - g. Ductwork, inclusive of all air turns, dampers, grilles, diffusers, fire dampers, sound traps, supports, bracing and fresh air/combustion air ducts;
 - h. Flashings, curbs and caps in connection with all equipment, piping and ductwork supplied under this Section;
 - i. Fire /smoke dampers;
 - j. Temperature control wiring and control devices;
 - k. Start up, adjusting, and balancing.
- C. Related Sections
 - 1. Division 07 Section for sheet metal flashing and trim
 - 2. Division 09 Section for finish painting
 - 3. Section 22 0000 - Plumbing
 - 4. Section 23 0500 - General Mechanical
 - 5. Section 23 0593 - Testing, Adjusting and Balancing for HVAC
 - 6. Section 23 0923 - Controls for HVAC
 - 7. Division 26 Section for basic electrical requirements
- D. The Contractor shall furnish all materials and labor under the scope of the Contract, unless otherwise noted. Anything accepted as standard trade practice reasonably incidental to the completion of the system shall be furnished without additional cost to the Owner. The Contractor shall understand that the work herein described shall be complete in every detail, notwithstanding every item necessarily involved is not particularly mentioned, and the Contractor shall be held to provide all labor and material necessary for the entire completion of the work.
- E. Comply with applicable requirements in ASHRAE 62.1 and ASHRAE 90.1

1.02 SUBMITTALS

- A. Product Data
 - 1. For each type of product indicated, include manufacturer's specifications, data sheets, and certified drawings on major equipment. Include physical and performance data such as weights, sizes, capacities, required clearances, performance curves, acoustical characteristics, finishes, color selection, and accessories.

2. Include certified drawings on major equipment.
- B. Coordination/Layout Shop Drawings
1. The Contractor shall submit for the approval of the Architect, shop drawings of proposed material and equipment that differ from the specified materials and equipment, and of any specified materials and equipment with special conditions and/or arrangements. These drawings shall show necessary modifications to plumbing, electrical, and mechanical work required by the proposed materials and equipment.
 2. Prepare complete consolidated and coordinated layout drawings for all new systems, and for existing systems that are in the same areas. Shop drawings shall be prepared using AutoCAD 2012 or newer and shall be drawn at a minimum $\frac{1}{4}'' = 1' - 0''$ scale.
 3. All drawings shall be fully coordinated with HVAC, Plumbing, Fire Protection, Electrical, Structural, and Architectural work. Drawings shall be coordinated and dimensioned indicating equipment, pipe, duct, fire protection, and electrical in relation to architectural and structural features. Indicate exact locations of valves, piping specialties, access doors, etc.
 4. Clearly identify and dimension the proposed locations of the principal items of equipment and adequate clearance for all equipment, piping, pumps, valves and other items. Provide detailed layout of all piping systems showing the proposed routes.
 5. Show the access means for all items requiring access for operations and maintenance.
 6. Submit shop drawings to Architect for approval, prior to fabrication or installation of any work. Do not install equipment or piping until layout drawings have been approved. Any work installed without prior shop drawing approval shall be removed at the Contractor's expense.
- C. Equipment manufacturer shall design, construct, and certify that his equipment satisfies the special minimum seismic resistance requirements and shall submit calculations or test results supporting his certification.
- D. Field quality-control test reports.
- E. Operation and maintenance data
1. Contractor shall provide all operating and maintenance instructions provided by the manufacturer, describing proper operation and maintenance of any equipment and devices installed. Operating and maintenance instructions shall cover maintenance, adjustment, and operation of each piece of apparatus.
 2. Contractor shall also provide a parts list of all equipment and component parts for all equipment under this Section. The equipment list shall include manufacturer's name, model number, and local representative, service facilities and normal channel of supply for each item.
 3. Data shall include a table of contents identifying items therein, and index tabs for each system. Neatly obscure or cross out inapplicable data from manufacturer's literature. Include the following:
 - a. Manufacturer's brochures, ratings, certified shop drawings, lubrication charts and data, and parts list with part numbers. Mark each sheet with equipment identification number and actual installed condition or system and location of installation. Specifically identify which options are provided.
 - b. Description of start-up and operating procedures for each system, including controls diagrams and description of operating sequences.
 - c. Recommend preventative maintenance schedule and procedures.
 4. Submit data to the Architect for approval. Final acceptance of the work will not be made until a satisfactory submission of this material is received and approved by the Architect.
- F. As-built Drawings
1. Complete and detailed shop drawings shall be maintained throughout the coordination and

construction phase, indicating all equipment and trades' work clearly. All equipment including piping, etc. shall clearly identify both top and bottom elevations as well as distances from equipment to established building lines. Coordinate with other trades and field conditions and show dimensions and details including building construction and access for servicing. All changes in the work shall be recorded on this set on a daily basis. In addition to changes made during course of work, show the following:

- a. Exact location, type and function of concealed valves and controllers.
 - b. Exact size, elevations and location of underground and under floor piping.
2. Submit to Architect for approval.
- G. Warranty
1. Equipment warranties shall be provided for all equipment, with all necessary information filled in, except purchase date, in favor of the Owner.
- H. Refer to mechanical equipment specified herein for additional requirements

1.03 DEMONSTRATION & TRAINING

- A. The Owner's authorized representative shall be instructed in the operation and servicing of all heating, ventilating, and air conditioning systems, subsystems and equipment.
1. Provide a minimum of one day of instruction time. All instruction shall be provided at no cost to the Owner.

PART 2 PRODUCTS

2.01 GENERAL

- A. Provide fan drives rated at 150% of motor horsepower. Drives shall be adjustable sheave type unless specified otherwise. Listed fan speeds are only approximate; select and/or change drives to operate at approximately midpoint of adjustable range after final balancing.
- B. Provide guards to enclose exposed moving equipment components in accordance with Title 8, California Code of Regulations. Fabricate belt guards with rigid angle iron frame, expanded metal screen, pivoted 4" diameter tachometer opening covers, and in two pieces to permit lubrication or sheave and belt adjustment without removing guard. Provide removable sheet metal guards at shafts and couplings and removable framed wire mesh guards at openings in mechanical systems.

2.02 REFRIGERANT PIPING AND APPURTENANCES:

- A. Refrigerant piping shall be Type "ACR" ASTM B 280, drawn temper, seamless copper tube.
- B. Pipe fittings and unions shall be wrought-copper with brazed joints. ASME B16.22. Mechanical joints on refrigerant piping are prohibited. All refrigerant piping joints shall be brazed. Lead-free silver solder, minimum 15% silver content. Harris "Stay Silv 15" or equal.
- C. Flexible connectors shall be bronze, double braided, with inlet and outlet connections as required. Metraflex BBS series or equal.
- D. Sight glasses shall be color change moisture indication type, replaceable element, filter screen and pad, sweat solder ends; Sporlan "See-All", Henry, or equal.
- E. Charging and purge valves shall be forged brass, diaphragm pack-less, globe type, angle or straight through, one end solder, one end flare; Henry 623 and 643 series, Sporlan, or equal.
- F. Solenoid valves shall be of forged brass, extended solder end connections, molded coil; Sporlan "E" series or equal. ARI 760 & UL 429

- G. Filter driers shall be replaceable media, angle type; Henry "Dri-Cor" or equal; ARI 730.
- H. Electronic thermostatic expansion valves shall have stainless steel body and connections, ceramic slide and port, linear flow capacity, continuous modulation, and direct coupling of motor and valve; Emerson "EX" series or equal.
- I. Pipe hangers: All refrigerant piping shall be supported 8' on center. Hangers and supports shall be as specified in Section 23 0500 - General Mechanical".
- J. Split system fan-coil units and heat pump units shall have brazed sweat-fitting connections on the refrigerant piping between the units with a flexible piping section at the outdoor unit.

2.03 CONDENSATE DRAINAGE PIPE

- A. Condensate drainage piping shall be Anvil, Mueller, Watts, or approved equal.
 - 1. 1 ¼ inch and larger shall be type DWV drawn temper seamless copper tube, ASTM B 306.
 - 2. 1 inch and smaller shall be type M, drawn temper, seamless copper tube, ASTM B 88.
- B. Drainage fittings shall be ASME B16.23, cast copper or ASME B16.29, wrought copper, solder-joint fittings. 1 ¼" & smaller, standard pressure fittings.
- C. Solder shall be ASTM B 32, lead free with ASTM B 813, water-flushable flux.
- D. Acidic condensate drainage pipe shall be Schedule 40 CPVC & fittings.

2.04 VALVES

- A. Ball Valves: Nibco T-685-80, Watts B-6080, or Kitz 58; bronze body, two-piece, full port, lever handle, 600 psi CWP.
- B. Check Valves:
 - 1. 2 inches and smaller:
 - a. Horizontal: Nibco T/S 413, Stockham B-321, or Kitz 22/23; bronze body, regrinding type, Y-pattern, renewable disc, Class 150.
 - b. Vertical: Nibco T-480 or Kitz 36; bronze body, inline lift type, Teflon seat, and discs, spring actuated 125 lb. SWP.
 - 2. 2½ inches and larger:
 - a. Horizontal: Nibco F918, Stockham G-931, or Kitz 78; IBBM, iron body, bolted cap, flanged, horizontal swing, renewable seats and discs, 125 lb. SWP
 - b. Vertical: Nibco F-910 or Kitz 7032; iron body, globe style, spring actuated, renewable seats and disc, 125 lb. class rating.
- C. Triple Duty Valves: Bell & Gossett, or approved equal, triple duty angle pattern valves, designed to perform the functions of a non-slam check valve, shut off valve, and calibrated balance valve.
- D. Gate Valves:
 - 1. 3 inches and smaller: Stockham B-136, bronze body, union bonnet, rising stem, solid wedge, copper-nickel disc, stainless steel seats, Class 200, with wheel handle.
- E. Butterfly Valves: Butterfly valves may be used in lieu of gate valves 2½" and larger.
 - 1. 2½" and larger: Nibco WD/LD 2000 series, Demco series NE, or Kitz 6121/6123 iron body, stainless steel stem, bronze disc, "Buna N" seat, throttling and memory stop handle.
- F. Air Eliminators: Air vents shall be installed at all high points in all water piping systems.
 - 1. Automatic air vents: Spirtotherm "Spirotop" Air Release Valve, cast brass, rated for 150 psig design pressure and 270°F operating temperature. Units shall include non-ferrous floats, stainless steel linkage and a Viton seal, which closes against a brass spring operated seat.
 - 2. Manual air vents: 1" IPS x 2" long air chambers with readily accessible Dole No. 10 vent

valve and 1/8" copper tubing.

- G. Circuit Setters: ITT Bell & Gossett, Circuit Setter Plus series, Model CB, calibrated balance valves with NPT and solder connections. Valves shall be designed to allow installing contractor to pre-set balance points for proportional system balance prior to system start-up. All valves 1/2" to 3" pipe size to be of bronze body/brass ball construction with glass and carbon filled TFE seat rings. Valves to have differential pressure read-out ports across valve seat area. Read-out ports shall be fitted with internal EPT inserts and check valves. Valve bodies to have 1/4" NPT tapped drain/purge port. Valves shall have memory stop feature to allow valve to be closed for service and then reopened to set point without disturbing balance position. All valves to have calibrated nameplates to assure specific valve settings. Valves shall be designed for positive shut-off.
- H. All valves, except pressure reducing and control valves, shall be the same size as the pipe to which they are installed.
- I. Provide a union immediately downstream from each valve, unless the valve is flanged.
- J. All valves shall be installed with the stem 45 degrees above horizontal, if possible. In no case shall the stem be installed below horizontal.

2.05 UNIONS

- A. Steel Pipe: malleable iron, 150 lb., ground joint, Anvil figure 463, Kuhns, or equal.
- B. Copper Pipe: soldered joint, Nibco series 633 or 733, Mueller, or equal.
- C. Dielectric: Epco, Watts, ins, or equal.

2.06 DIELECTRIC FITTINGS

- A. Precision Plumbing Products, "Clear Flow" series, threaded dielectric fittings, sizes 19100P thru 19195P.
- B. Dielectric fittings shall have zinc electroplated steel casing, and NSF/FDA listed lining. Fittings shall meet the requirements of ASTM standard F1545 for continuous use at temperatures up to 225°F (- +5°F) and for pressures up to 300 psi, and shall achieve a dielectric waterway in all potable water and appropriate HVAC applications.

2.07 INLINE EXHAUST FANS

- A. Greenheck "CSP-A" series, or approved equal, direct drive premium inline cabinet centrifugal exhaust fans, as scheduled on the Drawings. Each fan shall bear the AMCA seal for both sound and air performance, shall be UL Listed 507 - Electric Fans, and shall bear a permanently affixed manufacturer's nameplate containing the model number and individual serial number.
- B. The fan wheel shall be forward curved, centrifugal, and constructed of galvanized steel. The fan wheel shall be statically and dynamically balanced in accordance to AMCA Standard 204-05.
- C. The motor enclosures shall be open drip-proof (ODP), opening in the frame body and or end brackets. Motors shall be mounted on vibration isolators and be accessible for maintenance. Motors shall be compatible for use with speed controls and have thermal overload protection. Motor to be an electronic commutation (EC) motor specifically designed for fan applications. AC induction type motors are not acceptable. Motors shall be permanently lubricated with heavy-duty ball bearings to match the fan load and prewired to the specific voltage and phase. Internal motor circuitry shall convert AC power supplied to the fan to DC power to operate the motor. Motor shall be speed controllable down to 20% of full speed (80% turndown). Speed shall be controlled by either a potentiometer dial mounted on the motor or by a 0-10 VDC signal. Motor shall be a minimum of 85% efficient at all speeds.

- D. The fan housing shall be constructed of heavy gauge galvanized steel. The interior shall be lined with 0.5 inches of acoustical insulation.
- E. The outlet shall be field rotatable from horizontal to vertical discharge. The duct collar shall include a spring-loaded aluminum backdraft damper.
- F. The grille shall be designer type, constructed of high impact polystyrene for sizes 50 thru 390 and constructed of aluminum non-yellowing for size 410.
- G. The fan shall have external electrical access. Internal components shall be easily accessible through the access panel.
- H. Each fan shall be complete with all options and accessories as scheduled on the Drawings.

2.08 CEILING MOUNTED EXHAUST FANS

- A. Greenheck "SP-A" series, direct drive premium ceiling mounted centrifugal exhaust fans, as scheduled on the Drawings, or approved equal.
- B. Fans shall have performance capabilities up to 1,600 cubic feet per minute (cfm) and static pressure to 0.75 inches of water gauge. Maximum operating temperatures shall be 130°F.
- C. Fan wheel shall be forward curved, centrifugal type, constructed of galvanized steel and statically and dynamically balanced in accordance to AMCA Standard 204-05.
- D. Motor to be an electronic commutation (EC) motor specifically designed for fan applications. AC induction type motors are not acceptable. Motors shall be permanently lubricated with heavy-duty ball bearings to match the fan load and prewired to the specific voltage and phase. Internal motor circuitry shall convert AC power supplied to the fan to DC power to operate the motor. Motor shall be speed controllable down to 20% of full speed (80% turndown). Speed shall be controlled by either a potentiometer dial mounted on the motor or by a 0-10 VDC signal. Motor shall be a minimum of 85% efficient at all speeds.
- E. Motor enclosures shall be open drip-proof (ODP), opening in the frame body and/or end brackets. The motors shall be mounted on vibration isolators and be accessible for maintenance. Motors shall have thermal overload protection.
- F. The fan housing shall be constructed of heavy gauge galvanized steel. The interior shall be lined with 0.5 inches of acoustical insulation.
- G. The outlet shall be field rotatable from horizontal to vertical discharge. The duct collar shall include a spring-loaded aluminum backdraft damper.
- H. The grille shall be designer type, constructed of high impact polystyrene.
- I. The fan shall have external electrical access.
- J. Fully adjustable mounting brackets shall be included for multiple installation conditions.

2.09 SPLIT SYSTEM HEAT PUMPS (DUCTLESS)

- A. Mitsubishi PUZ/PKA heat pump system as scheduled on the Drawings or approved equal. The system shall be of Variable Speed Inverter Compressor technology and shall consist of a horizontal discharge, single phase outdoor unit, and a matched capacity indoor section that shall be equipped with a wireless wall-mounted controller.
- B. Quality Assurance
 - 1. The units shall be tested by a Nationally Recognized Testing Laboratory (NRTL) and shall bear the ETL label.
 - 2. All wiring shall be in accordance with the National Electrical Code (N.E.C.) and local codes

as required.

3. The units shall be rated in accordance with Air-conditioning, Heating, and Refrigeration Institute's (AHRI) Standard 210/240 and bear the ARI Certification label.
4. The units shall be manufactured in a facility registered to ISO 9001 and ISO 14001, which is a set of standards applying to environmental protection set by the International Standard Organization (ISO).
5. A dry air holding charge shall be provided in the indoor section.
6. The outdoor unit shall be pre-charged with R-410A refrigerant for 70 feet of refrigerant tubing.
7. The units shall have a manufacturer's parts and defects warranty for 5 years from date of installation. The compressor shall have a warranty of 7 years from date of installation

C. Outdoor Unit (PKA) - General

1. The outdoor unit shall be equipped with an electronic control board that interfaces with the indoor unit to perform all necessary operation functions.
2. The outdoor unit shall be capable of cooling operation down to ambient temperature of 0°F for heat pump systems and -20°F for cooling only systems without additional low ambient controls (optional wind baffle shall be required).
3. The outdoor unit shall be able to operate with a maximum height difference of 100 feet between indoor and outdoor units.
4. The outdoor unit shall be pre-charged for a maximum of 70 feet of refrigerant tubing.
5. The outdoor unit shall be completely factory assembled, piped, and wired. Each unit must be test run at the factory.
6. Outdoor unit sound level shall not exceed:

| Outdoor Unit Sound Level | | |
|--------------------------|----------|----------|
| Model Numbers | Cooling | Heating |
| PUZ(Y)-A12NKA7 | 44 dB(A) | 46 dB(A) |
| PUZ(Y)-A24NHA7 | 47 dB(A) | 48 dB(A) |

D. Outdoor Unit Components

1. Cabinet
 - a. The casing shall be constructed from galvanized steel plate, finished with an electrostatically applied, thermally fused acrylic or polyester powder coating for corrosion protection and have a Munsell 3Y 7.8/1.1 finish.
 - b. Mounting feet shall be provided and shall be welded to the base of the cabinet and be of sufficient size to afford reliable equipment mount and stability.
 - c. Easy access shall be afforded to all serviceable parts by means of removable panel sections.
 - d. The fan grill shall be of ABS plastic.
2. Fan
 - a. The outdoor unit shall be furnished with a single DC fan motor.
 - b. The fan blade(s) shall be of aerodynamic design for quiet operation, and the fan motor bearings shall be permanently lubricated.
 - c. The outdoor unit shall have horizontal discharge airflow. The fan shall be mounted in front of the coil, pulling air across it from the rear and dispelling it through the front. The fan shall be provided with a raised guard to prevent external contact with moving parts.
3. Coil

- a. The L shaped condenser coil shall be of copper tubing with flat aluminum fins to reduce debris build up and allow maximum airflow. The coil shall be protected with an integral metal guard.
 - b. Refrigerant flow from the condenser shall be controlled by means of an electronic linear expansion valve (LEV) metering device. The LEV shall be control by a microprocessor-controlled step motor.
 - c. All refrigerant lines between outdoor and indoor units shall be of annealed, refrigeration grade copper tubing, ACR Type, meeting ASTM B280 requirements, individually insulated in twin-tube, flexible, closed-cell, CFC-free (ozone depletion potential of zero), elastomeric material for the insulation of refrigerant pipes and tubes with thermal conductivity equal to or better than 0.27 BTU-inch/hour per Sq Ft /°F, a water vapor transmission equal to or better than 0.08 Perm-inch and superior fire ratings such that insulation will not contribute significantly to fire and up to 1" thick insulation shall have a Flame-Spread Index of less than 25 and a Smoke-Development Index of less than 50 as tested by ASTM E 84 and CAN / ULC S-102.
4. Compressor
- a. The compressor shall be a DC twin-rotor rotary compressor with Variable Speed Inverter Drive Technology.
 - b. The compressor shall be driven by inverter circuit to control compressor speed. The compressor speed shall dynamically vary to match the room load for significantly increasing the efficiency of the system which shall result in significant energy savings.
 - c. To prevent liquid from accumulating in the compressor during the off cycle, a minimal amount of current shall be automatically, intermittently applied to the compressor motor windings to maintain sufficient heat to vaporize any refrigerant. No crankcase heater is to be used.
 - d. The outdoor unit shall have an accumulator and hig- pressure safety switch. The compressor shall be mounted to avoid the transmission of vibration.
5. Electrical
- a. The electrical power of the unit shall be 208volts or 230 volts, single phase, 60 hertz. The unit shall be capable of satisfactory operation within voltage limits of 198 volts to 253 volts.
 - b. Power for the indoor unit shall be supplied from the outdoor unit via Mitsubishi Electric A-Control using (3) 14/16 gauge AWG conductors plus ground wire connecting the units.
 - c. The outdoor unit shall be controlled by the microprocessor located in the indoor unit.
 - d. The control signal between the indoor unit and the outdoor unit shall be pulse signal 24 volts DC
- E. Wall-Mounted Indoor Unit (PKA)
1. General:
 - a. The wall-mounted indoor unit shall be factory assembled, wired and run tested. Contained within the unit shall be all factory wiring, piping, control circuit board and fan motor. The unit shall have a self-diagnostic function, 3-minute time delay mechanism, an auto restart function, and a test run switch. Indoor unit and refrigerant pipes shall be charged with dehydrated air before shipment from the factory.
 2. Cabinet:
 - a. All casings shall have the same white finish.
 - b. Multi directional drain and refrigerant piping offering 4 directions for refrigerant piping and 2 directions for draining are required.
 - c. There shall be a separate back plate which secures the unit firmly to the wall.
 3. Fan:
 - a. The indoor fan shall be statically and dynamically balanced to run on a single motor with

- permanently lubricated bearings.
- b. A manual adjustable guide vane shall be provided with the ability to change the airflow from side to side (left to right).
- c. A motorized air sweep louver shall provide an automatic change in airflow by directing the air up and down to provide uniform air distribution.
- 4. Filter:
 - a. Return air shall be filtered by means of an easily removable, washable filter.
- 5. Coil:
 - a. The indoor coil shall be of nonferrous construction with smooth plate fins on copper tubing. The tubing shall have inner grooves for high efficiency heat exchange. All tube joints shall be brazed with phos-copper or silver alloy.
 - b. The coils shall be pressure tested at the factory.
- 6. Electrical:
 - a. The electrical power of the unit shall be 208 volts or 230 volts, 1 phase, 60 hertz. The system shall be capable of satisfactory operation within voltage limits of 198 volts to 253 volts. The power to the indoor unit shall be supplied from the outdoor unit, using the Mitsubishi Electric A-Control system. For A-Control, a 3-conductor AWG-14/16 wire with ground shall provide power feed and bi-directional control transmission between the outdoor and indoor units.

F. System Control

- 1. The control system shall consist of a minimum of 2 microprocessors, one on each indoor and outdoor unit, interconnected by a single non-polar two-wire cable. The microprocessor located in the indoor unit shall have the capability of monitoring return air temperature and indoor coil temperature, receiving and processing commands from a wireless or wired controller, providing emergency operation and controlling the outdoor unit. The control signal between the indoor and outdoor unit shall be pulse signal 24 volts DC. Indoor units shall have the ability to control supplemental heat via connector CN24 and a 12 VDC output.
- 2. For A-Control, a 3 conductor 14-gauge AWG wire with ground shall provide power feed and bi-directional control transmission between the outdoor and indoor units. If code requires a disconnect mounted near the indoor unit, a TAZ-MS303 3-Pole Disconnect shall be used - all three conductors must be interrupted.
- 3. The system shall be capable of automatic restart when power is restored after power interruption. The system shall have self-diagnostics ability, including total hours of compressor run time. Diagnostics codes for indoor and outdoor units shall be displayed on the wired controller panel.
- 4. The indoor unit control board shall have auxiliary control contact connectors to provide:

| Function / Model | PKA |
|-------------------------|-----|
| CN-2L - Lossnay Control | X |
| CN-24(152) Back-up Heat | X |
| CN-32 - Remote Switch | X |
| CN-51 - Central Control | X |
| CN-105 - IP Terminal | X |

- G. Mitsubishi universal thermostat interface kits (PAC-US444CN-1) shall be provided per each indoor fan coil unit to allow for 3rd party control via 5 or 7 wire 24V connections. A separate 24V 20VA transformer shall be field supplied per indoor fan coil unit to power the 3rd party thermostat controller.

2.10 SPLIT SYSTEM OUTDOOR HEAT PUMP UNITS (DUCTED)

- A. Carrier model 25HHA air-cooled, outdoor heat pump units as scheduled on the Drawings or

approved equal. The unit shall consist of a scroll-type hermetic compressor, an air-cooled coil, propeller-type condenser fan, and a control box. Units will be used in a refrigeration circuit to match up to a packaged fan coil.

B. Quality Assurance

1. Units shall be rated in accordance with the latest edition of AHRI Standard 210.
2. Units shall be certified for capacity and efficiency and listed in the latest AHRI directory.
3. Unit construction shall comply with latest edition of ANSI/ASHRAE and with NEC.
4. Units shall be constructed in accordance with UL standards and shall carry the UL label of approval.
5. Unit cabinet will be capable of withstanding Federal Test Method Standard No. 141 (Method 6061) 500-hour salt spray test.
6. Air-cooled condenser coils shall be leak tested and pressure tested.
7. Unit shall be constructed in ISO9001 approved facility.

C. Construction

1. The outdoor units shall be factory assembled, single piece, air-cooled heat pumps. All factory wiring, piping, controls, compressor, refrigerant charge "Puron" (R--410A), and special features required prior to field start-up shall be contained within the unit enclosure.
2. Unit cabinet shall be constructed of galvanized steel and bonderized.
3. Fans
 - a. Condenser fan shall be direct-drive propeller type, discharging air horizontally.
 - b. Condenser fan motors shall be totally enclosed, 1-phase type with class B insulation and permanently lubricated bearings. Shafts shall be corrosion resistant.
 - c. Fan blades shall be statically and dynamically balanced.
 - d. Condenser fan openings shall be equipped with coated steel wire safety guards.
4. Compressor
 - a. Compressor shall be a scroll-type, hermetically sealed.
 - b. Compressor shall be mounted on rubber vibration isolators.
5. Condenser Coil
 - a. Condenser coil shall be air cooled.
 - b. Coil shall be constructed of aluminum fins mechanically bonded to copper tubes, which are then cleaned, dehydrated, and sealed.

D. Refrigeration Components

1. Refrigeration circuit components shall include liquid-line front-seating shutoff valve with sweat connections, vapor-line front-seating shutoff valve with sweat connections, system charge of "Puron" (R--410A) refrigerant, and compressor oil.
2. Unit will be equipped with high-pressure switch, low pressure switch and filter drier for Puron refrigerant.

E. Accessories

1. Evaporator freeze thermostat
2. Liquid line solenoid valve
3. Low-ambient pressure switch
4. Crankcase heater
5. Isolation relay

2.11 SPLIT SYSTEM INDOOR FAN COIL UNITS

- A. Carrier model FV4C multi-position fan coil units as scheduled on the Drawings or approved equal. Units shall be complete with refrigerant coil, fan with ECM motor, piping connectors, and electrical controls.
- B. The pre-painted galvanized sheet metal cabinet shall be modular with sweat connections and be

fully lined with 1-inch thick insulation with vapor barrier and shall have multiple electrical entry for both high and low voltage service. The cabinet shall meet requirements of a 2% cabinet leakage rate when tested at 1.0 inches of static pressure. A low voltage terminal strip shall hold connections within the cabinet.

- C. The fan shall have an Electronically Commutating Motor (variable speed) with ultra-low power consumption during fan only operation.
- D. The units heat transfer technology shall include grooved copper tubing, lanced sine wave aluminum fins, and a factory installed bi-flow hard shut-off Thermostatic Expansion Valve (TXV) that provides compressor protecting operation at all recommended conditions.
- E. The coils shall be sloped with an overflow feature that allows condensate to exit the unit without damage to product under clogged primary and secondary line conditions. The drain pans shall be constructed of injection molded glass-filled polycarbonate engineered resin material with brass corrosion-free primary and secondary drain connections.
- F. The filter rack door shall be insulated. Filters shall be factory supplied and made of cleanable polyester filter media. The filters shall be easily removable without the use of tools.
- G. Control shall be by and "Easy Select Board". A plug connection shall be factory provided for installation of accessory heater packages. A replaceable 5-amp blade-type auto fuse shall protect against transformer secondary short.
- H. Accessories
 - 1. 5 kW electric heater, non-fused, 1 phase, with relays.

2.12 REGISTERS, GRILLES AND DIFFUSERS

- A. All terminals shall be steel and shall be factory painted. The finish shall be #26 white. The finish shall be an anodic acrylic paint, baked at 315°F for 30 minutes. The pencil hardness must be HB to H. The paint must pass a 100-hour ASTM B117 Corrosive Environments Salt Spray Test without creepage, blistering or deterioration of film. The paint must pass a 250-hour ASTM D870 Water Immersion Test. The paint must also pass the ASTM D2794 Reverse Impact Cracking Test with a 50-inch pound force applied.
- B. The manufacturer shall provide published performance data for the diffusers and grilles. The diffuser shall be tested in accordance with ANSI/ASHRAE Standard 70-1991.
- C. Air terminals for installation in gypsum board shall have a 1" border for surface mounting. All air terminals for installation in lay-in ceilings shall have a lay-in frame to match the specified grid system.
 - 1. CR & EG - Ceiling Return Grilles & Ceiling Exhaust Grilles
 - a. Eggcrate ceiling exhaust and ceiling return grilles shall be Titus model 50F, as scheduled on the Drawings or equal. Return grilles must provide a free area of at least 90%. Outer borders shall be constructed of heavy extruded aluminum with a thickness of 0.040-0.050 inch and shall have countersunk screw holes for a neat appearance. Border width shall be 1¼ inches on all sides and shall be interlocked at the four corners and mechanically staked to form a rigid frame.
 - 2. DSD - Duct Supply Diffusers
 - a. Aluminum duct supply grilles shall be Titus direct spiral duct-mounted supply grilles, model S300FS (double deflection) as scheduled on the Drawings or equal. The deflection blades shall be available parallel to the long or short dimension of the grille. All supply grilles shall be constructed with radius end caps and foam gaskets for a tight seal to the duct diameter. All supply grilles shall be constructed with a 1-³/₈ inch wide border.
 - b. Blades shall be constructed of heavy duty extruded aluminum and shall be spaced ¾-

inch apart. Blades shall extend completely through the side frame on each side to ensure stability throughout the complete cfm operating range of the grille. Blades shall be individually adjustable without loosening or rattling and shall be securely held in place with tension wire.

3. WRG - Wall Return Grilles
 - a. Steel wall return grilles shall be Titus Model 350ZRL (¾-inch blade spacing), as scheduled on the Drawings or approved equal. The fixed deflection blades shall be available parallel to the long or short dimension of the grille. Construction shall be of steel with a 1¼-inch wide border on all sides. Screw holes shall be countersunk for a neat appearance. Corners shall be welded with full penetration resistance welds.
 - b. Deflection blades shall be contoured to a specifically designed and tested cross-section to meet published test performance data. Blades shall be firmly held in place by mullions from behind the grille and fixed to the grille by welding in place. Blade deflection angle shall be available at 0°.
4. DL - Door Louvers
 - a. Door louvers shall be Titus model T-700, as scheduled on the Drawings or equal. Construction shall be of steel with a 1¼-inch border width. The border and blades shall be of 20-gauge steel. Inverted V-blades with a deflection angle of 77° shall be used to create a sight proof design and provide additional stiffness to the grille. Corners shall be welded with full penetration resistance welds with a reinforcing patch. Screw holes shall be countersunk.

2.13 ACCESS PANELS

- A. Where construction is not inherently accessible, provide adequately sized and conveniently located access doors in ceilings, walls, and furring for access to controls and for servicing valves, equipment, etc.
 1. Fire Rated walls and ceilings: Milcor, Style UFR, UL Class B, 1½ hour rating, insulated, self-closing, self-latching, flush key operated cylinder lock, interior latch release. Minimum size shall be 12" x 12". Provide larger sizes where required.
 2. Drywall ceilings or walls: Milcor, Style DW, prime coated steel, flush screwdriver-operated cam lock. Minimum size shall be 12" x 12". Provide larger sizes where required.
 3. Masonry walls: Milcor, Style M, prime coated steel, flush screwdriver-operated cam lock. Minimum size shall be 12" x 12". Provide larger sizes where required.
 4. Tiled walls: Milcor, Style MS, satin finish stainless steel, flush screwdriver-operated cam lock.
 5. Plastered walls and ceilings: Milcor, Style K, prime coated steel, flush screwdriver-operated cam lock. Minimum size shall be 12" x 12". Provide larger sizes where required.
- B. Doors shall be delivered to the General Contractor for installation.

2.14 VIBRATION ISOLATORS

- A. Unless otherwise noted on the equipment schedule, all mechanical equipment shall be mounted on vibration isolators to prevent the transmission of vibration and mechanically transmitted sound to the building structure. All isolators shall be Mason Industries or approved equal.
- B. Spring equipment mounts, earthquake motioned restrained:
 1. Mounts shall incorporate a single spring vibration isolator built into a welded steel mount assembly, designed and engineered to limit movement of supported equipment during an earthquake without degrading the vibration isolation of the spring during normal equipment operating conditions.
 2. Mounts shall incorporate a welded steel plate and motion limit assembly, and steel spring isolator, engineered as a system to accept a force of 1.3 times the rated load capacity of the

- spring isolator without yield or failure, and shall limit movement of the point of level bolt connection to supported equipment to 0.75 inches in any direction, relative to any fixed point on the mount assembly, while subjected to the minimum force specified.
3. The motion limit assembly shall be welded to a steel base plate having a ¼" thick ribbed neoprene noise stop pad, and drilled holes for bolting to supporting structures.
 4. Springs shall be wound steel, using high strength, heat treated spring alloy steel and shall have a horizontal spring stiffness equal to or greater than 1.3 times the rated vertical spring stiffness. The outside diameter of each spring shall be a minimum of 0.8 times the rated vertical spring height.
 5. Springs shall be selected to provide the tabulated minimum operating static deflections and shall provide a 50% overload capacity before reaching solid state. Springs shall be designed to reach solid state before exceeding the spring steel fatigue point.

2.15 DUCTWORK

A. Sheet Metal Ductwork:

1. Ducts and plenums shall be fabricated and installed in conformance with the latest editions of: NFPA Pamphlet No. 90A; California Building Code; California Mechanical Code and the SMACNA HVAC Duct Construction Standards (Metal & Flexible). Ducts and plenums shall be constructed of G-60 coated galvanized steel of lockforming grade conforming to ASTM A653 and A924 standards. Seals shall be airtight Class "B" seals at all transverse joints and longitudinal seams. Tables and figures hereinafter referenced are from the 2005 edition of the SMACNA HVAC Duct Construction Standards (Metal and Flexible).
2. Rectangular duct construction shall conform to Table 2-3. All transverse joints shall be flanged per Table 2-32, with corner closures or "Duct Mate" flanged connections with corner closures per Figure 2-16 or 2-17. Elbows shall be standard radius (Type RE 1) or square throat with vanes (Type RE 2) per Figure 4-2, with double thickness turning vanes per Figures 4-3 and 4-4. Offsets and transitions shall be per Figure 4-7. Supply, return, and exhaust branch connections shall be per Figure 4-5 or 4-6. Splitters SHALL NOT be used.
3. Round ducts shall be spiral, United McGill or equal. All transverse joints and longitudinal seams shall have Class "B" seals. All branches in round duct systems shall be made with factory fabricated reducing wye branches. Duct turns shall be made with standard, factory fabricated, three-piece elbows.
4. Lined ducts shall be fabricated such that the net inside dimensions equals the duct sizes shown on the Drawings.
5. Flexible ducts shall be acoustical type, Flexmaster "6M", Casco "Silent Flex - SF-18M", or approved equal. Flexible ducts shall be used only where shown on the Drawings, and maximum length of any given flexible duct shall not exceed 7 feet. Galvanized sheet metal elbows shall be used for turns greater than 45 degrees on flexible ducts 10 inches and larger. Connections to rectangular ducts shall be made with "spin-in" fittings with air scoops. The installation of flexible ducts shall conform to Figure 3-10, with the exceptions noted herein.
6. Supports for horizontal ducts and plenums shall be fabricated per Figures 5-5 and 5-6 and Tables 5-1, 5-2 and 5-3. The maximum distance between hangers shall be 8 feet for rectangular ducts and 12 feet for round ducts. Attachments to the structure shall be made with adequately sized lag bolts for strap hangers and adequately sized machine bolts and side beam brackets for rod hangers. Supports for vertical ducts shall be band iron strap or angle bracket type per Figures 5-8 and 5-9.
7. All roof-mounted ductwork shall be water tight and sloped to shed water. All transverse joints shall be T-25 flanged Ductmate "25", or approved equal.
8. Outside air intakes shall be type 316 stainless steel.

B. Fiberglass Ductwork:

1. Fiberglass ductwork is unacceptable and may not be used on this project.

C. Specialties:

1. Duct Mounted Access Doors
 - a. Including those for removing filters, duct access doors shall be fabricated as detailed in Figure 7-2, with sash locks, piano hinges, and cam latches. Round duct shall be fabricated as detailed in Figure 7-3.
 - b. Access doors shall be double wall, rectangular, insulated or uninsulated same as duct. Insulation fill and thickness shall be as indicated for pressure class.
 - c. Access doors shall have a vision panel and an unobstructed full swing.
 - d. Fabricate doors airtight and suitable for duct pressure class.
2. Dampers:
 - a. Provide butterfly or multiple blade dampers where indicated on the Drawings or as required for balancing air quantities, to values shown without generating excessive noise. Provide Duro-Dyne "KS-385", or approved equal, locking quadrants on each manual damper. Locate dampers in furred ceilings near access panels where possible.
 - b. Butterfly dampers shall be constructed as per Figure 7-4, Figures A, B, and C.
 - c. Multi-blade dampers shall conform to Figure 7-5.
 - d. Motorized dampers - See Temperature Controls.
3. Remote Actuators: Young Regulator Company, Round Cable Controlled Dampers Model 5020-CC or 830A-CC (rectangular) and Remote Cable Control System Kit Model 270-301EZ. All dampers in inaccessible ceilings shall have remote actuators.
4. Air Extractors: Duct mounted volume extractors made of galvanized steel with 1-inch blade spacing, Titus model "AG-45", or equal.
5. Flexible Duct Connections: Duro-Dyne "Metal-Fab" with Duro-Dyne, Ventfabrics "Ventglas", or approved equal. Install at each point where a blower unit is connected to a duct. A minimum clearance of 3" between the duct and the source of vibration shall be maintained. Install per Figure 7-8.
6. Screens: Install removable bird screens at ALL outside air intakes and exhaust air discharges. Screens shall be fabricated from 1/2" x 14-gauge mesh secured in full frames. Screens and frames shall be constructed of the same material as the duct, hood, or equipment to which attached.
7. Access Panels: Milcor, Style M, prime coated steel, or approved equal. Minimum size shall be 10" x 10". Provide larger sizes where required. Locks shall be flush, screwdriver operated. Provide as required for concealed ducts at all fire dampers, electric duct heaters, and automatic dampers except at suspended acoustical ceilings.
8. Joints: Tape all joints airtight using Hardcast - Carlisle, type "DT" pressure-less tape and "RTA 50" sealant, or McGill AirSeal, "Uni-Flex" duct sealer. Install per manufacturer's directions.

2.16 INSULATION

A. General

1. All duct insulation materials including jackets, tapes, adhesives and coatings shall meet ASTM E84 25/50 Flame Spread/Smoke Development requirements.

B. Exterior of Ductwork: (Flexible Duct Wrap)

1. Unless specified to be lined, all ductwork shall be wrapped with formaldehyde-free, flexible glass-fiber or mineral-wool, blanket type insulation with factory applied FSK aluminum foil facing. Thickness shall be 2 inches unless noted otherwise.
 - a. Johns Manville "Microlite EQ", Knauf Insulation "Friendly Feel", Owens Corning "SoftR Duct Wrap", or approved equal.

C. Interior of Ductwork: (Duct Liner)

1. All ducts exposed to the weather shall be internally insulated. All other ductwork within 10

feet of a fan (supply and return) shall be internally insulated. Duct liner shall be installed in supply and return ducts and plenums where noted on the Drawings. Exhaust ductwork need not be insulated.

2. Duct liner shall meet the requirements of ASTM C 1071, NFPA 90A or NFPA 90B Type I and Type II. Operating temperature shall meet ASTM C411. Microbial growth shall meet ASTM C1338, G21 and G22.
 - a. Type I - Plenum Liner Board: Johns Manville "Permacote Linacoustic R-300" or Knauf "Rigid Plenum Liner" or approved equal. Thickness shall be 1 ½ inches, unless otherwise noted.
 - b. Type II - Flexible Duct Liner: Johns Manville "Linacoustic RC" or Knauf "Sonic XP Duct Liner", with fire resistant facing; or approved equal. Thickness shall be 1 ½ inches, unless otherwise noted.

D. Refrigerant Piping:

1. Insulate all refrigerant suction lines, fittings, and valves with flexible elastomeric thermal insulation, Resolco Insul-Phen rigid closed cell phenolic foam, or equal, according to manufacturer's suggested installation procedures, UV protected.
2. Liquid, suction, and hot gas (where applicable) lines shall be insulated individually.
3. Oil equalization lines between multiple condensing units shall be insulated.

E. Piping insulation thickness shall be as follows:

| FLUID TEMPERATURE RANGE (°F) | CONDUCTIVITY RANGE (in Btu-inch per hour per square foot per °F) | INSULATION MEAN RATING TEMPERATURE (°F) | NOMINAL PIPE DIAMETER (in inches) | | | | |
|--|--|---|---|-----------|-----------|---------|--------------|
| | | | 1 and less | 1 to <1.5 | 1.5 to <4 | 4 to <8 | 8 and larger |
| | | | INSULATION THICKNESS REQUIRED (in inches) | | | | |
| Space cooling systems (chilled water, refrigerant and brine) | | | | | | | |
| 40-60 | 0.21-0.27 | 75 | 0.5 | 0.5 | 1.0 | 1.0 | 1.0 |
| Below 40 | 0.20-0.26 | 50 | 1.0 | 1.5 | 1.5 | 1.5 | 1.5 |

- F. All tanks, expansion tank, pumps, volutes, valves and strainers shall be completely insulated with ½" Armaflex glued and sealed, vapor tight, in place with Armstrong #520 adhesive.

2.17 FIRE/SMOKE DAMPERS

A. FSD-1:

1. Combination fire smoke dampers shall be Ruskin FSD 60 series or approved equal. Dampers shall be placed at locations shown and as detailed on the Drawings. Dampers shall meet the requirements of NFPA90A, 92A and 92B. Dampers shall have a fire rating of 1-1/2 hours, in accordance with the latest edition of UL555 and shall be classified as Leakage Class I Smoke Dampers in accordance with the latest version of UL555S. Dampers shall be FM approved and labeled as Specification Tested Products and shall be warranted to be free from defects in material and workmanship for a period of 5 years after date of shipment.
2. Each fire smoke damper shall be AMCA licensed and shall bear the AMCA Certified Ratings Seal for Air Performance. AMCA certified testing shall verify pressure drop does not exceed 03" w.g. at a face velocity of 1,000 fpm on a 24" x 24" damper. In addition, the dampers and their actuators shall have a UL555S elevated temperature rating of 250°F (121°C) or 350°F (177°C) depending upon the actuator.
3. Appropriate electric or pneumatic actuators shall be installed by the damper manufacturer at time of damper fabrication. Electric actuators shall have been energized hold open tested for a period of at least 1 year with no spring return failures.
4. Each fire smoke damper shall be equipped with a "controlled closure" quick detect heat-

actuated release device to prevent duct and HVAC component damage. Instantaneous damper closure using fusible links is unacceptable.

5. Damper frame (when size permits) shall be constructed using the "UniFrame Design Concept" (UDC) and shall be a roll-formed structural hat channel, reinforced at the corners, formed from a single piece of minimum 16-gauge galvanized steel. Damper blades shall be airfoil shaped with 13-gauge equivalent thickness formed from a single piece of galvanized steel. Bearings shall be stainless steel turning in an extruded hole in the frame. Blade edge seals shall be silicone rubber and galvanized steel mechanically locked in to the blade edge (adhesive type seals are not acceptable).
6. Each damper shall be supplied with a factory mounted sleeve of 17" minimum length. Each sleeve shall include a factory mounted access door.

PART 3 EXECUTION

3.01 SURFACE CONDITIONS

- A. Prior to commencing the work of this Section, the Contractor shall inspect the installed work of other trades and verify that their work is sufficiently complete to permit the start of work under this Section, and that the completed work will be in complete accordance with the original design. In the event of discrepancy, immediately notify the Architect and proceed as directed.

3.02 GENERAL INSTALLATION

- A. Provide all necessary cutting in connection with the work of this Section. No structural members shall be drilled, bored, or notched in a manner which will impair their structural capacity. All penetrations of concrete or masonry shall be made with core drills. No cutting shall be done without the approval of the Architect.

3.03 HEATING & AIR CONDITIONING EQUIPMENT INSTALLATION

- A. All units shall be set with curbs plumb, level, and securely attached through framed opening with bolts and/or lag screws as noted on the Drawings. Connections to ductwork shall be secured, filter racks shall be aligned, enclosures and ductwork connections shall be fully waterproofed, and all utility and control connections shall be complete.

3.04 INSULATION

- A. Exterior Ductwork:
 1. Duct wrap shall be cut in a manner to meet the manufacturers' stretch-out guideline to provide a 2" staple lap and have minimum compression at the corners. All joints shall be lapped 2" and stapled with outward clinching staples 2" o.c. The insulation shall be mechanically fastened to the underside of all ducts 24" wide or more using cup-head pins, weld pins, or stick pins with speed clips 18" on center. Insulation shall not be compressed to comply with required installed R-value. All joints and penetrations of the vapor barrier jacket shall be sealed with a minimum 3" wide matching pressure sensitive tape. Pressure-sensitive tape shall be firmly rubbed in place immediately after application using a "squeegee" type tool.
 2. When a vapor seal is required, two coats of vapor retarder mastic reinforced with one layer of 4" wide, open weave glass fabric may be used in lieu of pressure-sensitive tape. Mastic shall be brushed onto joint and glass fabric imbedded in it. A second coat of mastic shall be brushed over the glass fabric until the fabric is filled. Mastics shall be applied in accordance with application instructions on the container.
- B. Interior Duct Liner
 1. Apply to the inside face of ducts, coated side facing air stream. Fasten using fire retardant

- adhesive and secure with mechanical fasteners at 12" maximum o.c., both directions, for velocities up to 2,500 fpm. Velocities over 2,500 fpm shall have fastener spacing of 6" o.c.
2. Exposed edges must be factory or field coated with adhesive. Metal nosing shall be installed in all liner leading edges facing the airstream at fan discharge, at access doors, and at any interval of lined duct preceded by unlined duct.
 3. Insulation with torn or broken coatings shall be removed and replaced. Loose corners, edges, and butt joints will not be accepted.
 4. Maximum velocity: 5,000 ft/min.
- C. Refrigerant Piping:
1. The insulation shall be installed in accordance with the manufacturer's instructions. All joints and seams shall be sealed with waterproof vapor retarder adhesive. All pipes exposed to the weather shall be coated to protect the insulation from ultra-violet radiation in accordance with the manufacturer's published instructions.

3.05 FILTERS

- A. During construction, protect all filters upstream of air handling units with blankets of 2" fiberglass filter media or 2" disposable panel filters. UL Class 2 listed.
- B. Systems shall not be operated without properly installed filters. Filters used during construction shall be removed and replaced with new filters after construction is completed and the systems are ready for final acceptance by the owner.

3.06 VRF SPLIT SYSTEM INSTALLATION

- A. Contractor's Qualifications
 1. The mechanical contractor shall show having successfully installed a minimum of two Mitsubishi City Multi projects within the past 5 years. Provide for approval prior to construction, a written statement indicating the project names, dates completed, owners name and contact information.
- B. Installer Qualifications
 1. Installers for the Mitsubishi systems shall have at least (1) person factory trained and certified for installation and service of the systems by Mitsubishi Electric. This person shall, at all times, supervise the installation of all other installers and assure that all work is done in accordance with Mitsubishi requirements. All other installers shall be trained and certified in HVAC installation (included but not limited to refrigerant piping and controls) by a national or regionally recognized organization. Provide for approval, prior to construction, copies of installers certificates or other proof of qualifications.
- C. All units shall be set with curbs plumb, level, and securely attached through framed opening with bolts and/or lag screws as noted on the Drawings. Connections to ductwork shall be secured, filter racks shall be aligned, enclosures and ductwork connections shall be fully waterproofed, and all utility and control connections shall be complete.
- D. General:
 1. Rig and install in full accordance with manufacturer's requirements, project drawings, and contract documents. Refer to the manufacturer's installation manual for full requirements.
- E. Location:
 1. Locate indoor and outdoor units as indicated on drawings. Provide service clearance per manufacturer's installation manual. Adjust and level outdoor units on support structure.
- F. Components / Piping:
 1. Installing contractor shall provide and install all accessories and piping for a fully operational

- system. Refer to manufacturer's installation manual for full instructions.
2. Traps, filter driers, and sight glasses are NOT to be installed on the refrigerant piping or condensate lines.
 3. Standard ACR fittings rated for use with R410A are to be used for all connections. Proprietary manufacturer-specific appurtenances are not allowed.
 4. Refrigerant pipe for CITY MULTI shall be made of phosphorus deoxidized copper.
 - a. ACR Type-L "Annealed Temper": Soft copper pipe, can be easily bent with human's hand.
 - b. ACR Type L "Drawn Temper": Hard copper pipe (Straight pipe), being stronger than Type-O pipe of the same radical thickness.
 5. The maximum operation pressure of R410A air conditioner is 4.30 MPa [623psi] . The refrigerant piping should ensure the safety under the maximum operation pressure. Pipes of radical thickness 0.7mm or less shall not be used.
 6. Flare connection should follow dimensions provided in manufacturer's installation manuals.
- G. Insulation:
1. Refrigerant lines, as well as any valves, shall be insulated end to end with ½" closed-cell pipe insulation. If state or local codes require insulation other than that specified above, the greater insulation shall be used.
- H. Electrical:
1. Installing contractor shall coordinate electrical requirements and connections for all power feeds with electrical contractor. Refer to Division 26 for additional information.
- I. Third Party Controls:
1. Installing contractor shall coordinate all BAS/BMS control requirements and connections with controls contractor.

3.07 DUCTWORK

- A. All ductwork shall be installed within spaces provided, where possible. Ducts shall be installed true to line and grade, fully secured to structural framing with specified hangers and supports, insulated, and vibration isolated.
- B. Each section of supply air ductwork shall be cleaned, dust and oil free, at the shop using a degreasing agent and detergent and sealed airtight at both ends with visqueen and tape. Supply ducts shall be additionally cleaned with a disinfecting solution. Ends of all supply and internally insulated exhaust ducts shall be kept sealed until the time they are joined. When duct sections are joined, wipe down all interior surfaces with a clean tack cloth. If tack cloth shows any dust, then re-clean duct as described above. The intent is that no foreign matter be allowed to enter the ductwork at any time after factory cleaning and during construction.
 1. Submit detailed shop and field duct handling procedures for review.
 2. Unlined exhaust ducts shall be vacuum cleaned when installed, but shall otherwise be exempt from shop cleaning and sealing.

3.08 INSTALLATION, REFRIGERANT PIPING

- A. Piping installation shall comply with all federal, state, and local regulations and industry guidelines. In addition, the following practices shall be followed.
 1. All piping shall be stored with ends sealed to prevent entry of moisture and debris.
 2. A pipe cutter specific to the piping material applied shall be used.
 3. All factory and field cut tube ends shall be de-burred and cleaned.
 4. Flared fittings shall be formed using tools recommended by the equipment manufacturer.
 5. Flare nuts shall be tightened with torque wrench furnished by the equipment manufacturer.
 6. Piping shall be continuously purged with dry nitrogen while soldering. Care shall be taken

when soldering near valves or other equipment that may be damaged by extreme heat.

- B. Drawing plans, schematics, and diagrams indicate general location and arrangement of piping systems; indicated locations and arrangements were used to size pipe and calculate friction loss, expansion, pump sizing, and other design considerations. Install piping as indicated unless deviations to layout are approved on Shop Drawings.
- C. Install refrigerant piping according to ASHRAE 15.
- D. Install piping in concealed locations unless otherwise indicated and except in equipment rooms and service areas.
- E. Install piping indicated to be exposed and piping in equipment rooms and service areas at right angles or parallel to building walls. Diagonal runs are prohibited unless specifically indicated otherwise.
- F. Install piping above accessible ceilings to allow sufficient space for ceiling panel removal.
- G. Install piping adjacent to machines to allow service and maintenance.
- H. Install piping free of sags and bends. Install fittings for changes in direction and branch connections. Install piping as short and direct as possible, with a minimum number of joints, elbows, and fittings.
- I. Arrange piping to allow inspection and service of refrigeration equipment. Install valves and specialties in accessible locations to allow for service and inspection. Install access doors or panels as specified in Division 08 Section "Access Doors and Frames" if valves or equipment requiring maintenance is concealed behind finished surfaces.
- J. Install refrigerant piping in protective conduit where installed belowground. Install refrigerant piping in rigid or flexible conduit in locations where exposed to mechanical injury.
- K. Slope refrigerant piping as follows:
 - 1. Install horizontal hot-gas discharge piping with a uniform slope downward away from compressor.
 - 2. Install horizontal suction lines with a uniform slope downward to compressor.
 - 3. Use double-suction riser for maximum compressor efficiencies if load variation is expected.
 - 4. Install traps and double risers to entrain oil in vertical runs.
 - 5. Liquid lines may be installed level.
- L. When brazing or soldering, remove solenoid-valve coils and sight glasses; also remove valve stems, seats, and packing, and accessible internal parts of refrigerant specialties. Do not apply heat near expansion-valve bulb.
- M. Install piping with adequate clearance between pipe and adjacent walls and hangers or between pipes for insulation installation.
- N. All refrigerant piping and valves shall be identified.

3.09 TESTS, INSPECTIONS

- A. Contractor shall not allow or cause any work of this Section to be covered or enclosed until it has been inspected, tested, and approved by the Architect and the authorities having jurisdiction over the Work. Should any of this work be enclosed or covered up before such inspection, testing, and approval, this Contractor shall uncover the work, have the necessary inspections, tests, and approvals made and, at NO expense to the Owner, make all repairs necessary to restore both his work and that of other contractors which may have been damaged to be in conformity with the Contract Documents.

- B. Furnish all necessary labor, materials, and equipment for conducting tests, and pay all expenses in connection therewith. Should leaks develop while testing, repairs shall be made, and tests shall be repeated until a satisfactory test is obtained.
- C. In any test, proper safety procedures and equipment shall be used, including personal protective equipment such as protective eyewear and clothing. Installers shall always consider local conditions, codes and regulations, manufacturer's installation instructions, and Architects' /Engineers' specifications in any installation.
- D. Make all necessary control adjustments and balancing of air and water flows. Operate the entire system for a period of time not less than 3 working days for the purpose of proving satisfactory performance. During this period, instruct such persons as the Owner and/or Architect may designate in the proper operation of the systems. Should further adjustment prove necessary, operating tests shall be repeated until a satisfactory test result is obtained.
 - 1. Condenser water piping shall be hydrostatically tested at 125-psi pressure and proved tight before covering. Tests may be made in sections provided connection to service previously tested is included in each succeeding test. Systems shall be tight for eight hours.

3.10 REFRIGERANT PIPING TESTING

- A. Prior to charging with refrigerant, piping shall be tested for leaks under 550 psi pressure using a mixture of 95% nitrogen and 5% hydrogen gas. (WARNING! OXYGEN OR ACETYLENE SHALL NOT BE USED IN PLACE OF DRY NITROGEN. A VIOLENT EXPLOSION MAY RESULT!).
- B. All joints shall be tested for leaks using an electronic hydrogen leak detector. Pressure and leak tests on refrigeration piping and equipment shall be done in accordance with local code requirements and the American Standard Safety Code for Mechanical Refrigeration (ANSI B9.1).
- C. Piping shall be continuously purged with dry nitrogen while brazing. Care shall be taken when soldering near valves or other equipment that may be damaged by extreme heat.
- D. Be sure that all controls, relief valves or rupture discs that could be damaged by test pressure are removed before beginning pressure test.
- E. Precautions shall be taken to keep moisture out of the system, and a drier shall be used.
- F. After successful completion of pressure tests, the entire system shall be purged with dry nitrogen and then evacuated with a standard vacuum pump to remove all moisture and non-condensibles. Three evacuations shall be required, and shall be down to 500 microns absolute pressure. Break the first two vacuums with dry nitrogen. Charge with refrigerant after third evacuation.
- G. The contractor shall notify the Architect 48 hours prior to the time and date of the evacuation.
- H. The refrigerant charge shall be calculated and weighed into the system.
- I. Service technicians shall be certified in the use of CFC and HCFC refrigerant recovery and recycling equipment and shall use UL listed and labeled recovery equipment when discharging refrigerant.

3.11 CLEANUP

- A. Upon completion of the work of this Section, remove all material, debris, and equipment associated with or used in the performance of this Work.

END OF SECTION

SECTION 23 0500

GENERAL MECHANICAL

PART 1 GENERAL

1.01 SUMMARY

- A. The requirements of this Section shall apply to all work of Division 23. Drawings and general provisions of the contract, including General Conditions and Supplemental Conditions, and all Division 01 Sections apply to the work herein.
- B. Furnish and install any incidental work not shown or specified, which can be reasonably inferred as part of the work necessary to provide complete functional systems. When an item not shown or listed is clearly necessary for proper operation of equipment that is shown or listed, provide an item that will allow the system to function properly, at no increase in Contract Sum.

1.02 QUALITY ASSURANCE

- A. Regulatory compliance: All work performed under Division 23 shall comply with the latest currently adopted editions of all codes and regulations and all requirements of all Authorities having Jurisdiction. The following references and standards are hereby made a part of these sections and work shall conform to applicable requirements herein, except as otherwise specified herein or shown on the Drawings.
 - A. All work shall be done in conformity with all applicable local and state safety codes, ordinances and regulations. Additionally, all work shall conform to the latest editions of the following codes and standards:
 1. California Mechanical Code
 2. California Plumbing Code
 3. California Building Code
 4. California Fire Code
 5. California Green Building Code
 6. National Electric Code
 7. California Code of Regulations, including Titles 8, 17, 19, 20, 21, 22 and 24
 8. SMACNA Standards
 9. ASHRAE Standards 55 and 62.1
 10. Comply with all ADA requirements for disabled access.
 - B. Minimum requirements: The requirements of these are the minimum that will be allowed unless such requirements are exceeded by applicable codes or regulations, in which the regulatory codes or regulation requirements shall govern.
 - C. When the Contract Documents call for materials or construction of a higher standard than is required by the above, the Contract Document requirements shall take precedence over the requirements of the said laws, rules, and/or regulations, accepting that nothing in the Contract Documents shall be interpreted as permitting work in violation of said laws, rules, and/or regulations. The Contractor for this work shall furnish any additional materials and/or labor as may be required for compliance with these laws, rules, and/or regulations though such materials and/or labor are not specifically set forth in the Contract Documents, with no additional charges to Owner.
 - D. Seismic construction and restraints shall be in accordance with the requirements of the California Building Code and Title 17 and Title 24 of the California Code of Regulations. All equipment mounts, isolators, and hanging systems must meet DSA approval requirements.s.

- E. Comply with the Safety Orders issued by Cal-OSHA and any other regulations of the State of California and any districts having jurisdictional authority.

1.03 LICENSES, PERMITS, FEES

- A. The Contractors for this Section of work shall provide, procure and pay for all licenses, permits, fees, etc. as required to carry on and complete their work.

1.04 LICENSING REQUIREMENTS

- A. All work of Divisions 23 shall be performed by an appropriately licensed contractor. The licenses shall be current, valid through the term of the contract and in the name of the contractor.
- B. All HVAC work, which includes warm air heating systems and water heating pumps, ventilating systems, air conditioning systems, and ductwork, registers, flues, humidity, and thermostatic controls in connection with these systems, shall be performed by a C-20 - Warm-Air Heating, Ventilating and Air-Conditioning Contractor.

1.05 CONTRACT DRAWINGS

- A. The Contract Drawings indicate diagrammatically the general layout of the mechanical systems and other related work. Field verification of scaled dimensions taken from the Drawings is required. The Contractors for this Section of the work shall review and compare the Architectural, Structural, Plumbing, Mechanical and Electrical Drawings and all Owner supplied equipment Drawings, and adjust their work to be in conformity with the conditions indicated thereon. Discrepancies between different Drawings, between Drawings and actual field conditions, or between Drawings and Specifications, shall be brought to the attention of the Architect promptly for a determination of the modifications to be affected.

1.06 SUBMITTALS

- A. General:
 - 1. Before any fixtures, materials, or equipment are purchased, the Contractor shall submit to the Architect for approval, a complete list of materials, fixtures, and equipment, giving the manufacturers' names, catalog number, capacity, size, power requirements, and other pertinent data. Submittal lists and drawings shall be specifically applicable to this project, shall include identifying marks assigned by Specifications and Drawings, and shall not contain extraneous material or optional choices.
 - 2. The Contractor shall submit for the approval of the Architect, shop drawings of proposed material and equipment that differ from the specified materials and equipment, and of any specified materials and equipment with special conditions and/or arrangements. These drawings shall show necessary modifications of Owner, plumbing, electrical and mechanical work required by the proposed materials and equipment.
 - 3. Submittal of substitutions shall be limited to one proposal for each type or kind of item. If the first proposed product submittal is rejected, the Contractor shall then submit the first named or scheduled product.
 - 4. Contractor shall make all necessary field measurements and investigations to assure that the equipment and assemblies will meet contract requirements. Review of drawings and other material submitted shall not be construed as a complete check or constitute a waiver of the requirements of the Drawings and Specifications, but will indicate that the material submitted is acceptable in quality and utility. This review shall not relieve the Contractor of the responsibility to fit the proposed materials to the spaces provided, and to effect necessary rearrangement or construction of other work.

B. Welding

1. Before any welding is performed, the contractor shall submit to the Architect, copies of any welding procedure specifications and their supporting procedure qualification records for review and acceptance. Copies of welder qualification records shall be made available for review to the owner or his representative at the construction site.

1.07 DELIVERY, STORAGE, AND HANDLING

- A. Contractor shall be responsible for delivery, storage, protection and placing of all equipment and materials.
- B. Contractor shall protect the work and materials from damage during construction. Equipment stored at the jobsite shall be protected from dust, water or other damage, and be covered if equipment is exposed to weather. Protect interiors of new equipment and piping systems against entry of foreign matter. Clean both inside and outside before painting or placing equipment in operation.
- C. Any items damaged shall be repaired or replaced, at no additional cost to the Owner.
- D. Cleanliness of Piping and Equipment Systems:
 1. Exercise care in storage and handling of equipment and piping material to be incorporated in the work. Remove debris arising from cutting, threading and welding of piping.
 2. Piping systems shall be flushed, blown or pigged as necessary to deliver clean systems.
 3. Contractor shall be fully responsible for all costs, damage, and delay arising from failure to provide clean systems.

1.08 COOPERATION WITH OTHER TRADES

- A. Cooperate fully with other trades doing work on the project as may be necessary for the proper completion of the project. Refer to the Structural, Plumbing, and Electrical Drawings for details of the building structure and equipment installation that will tend to overlap, conflict with, or require coordination with the work of this Section, and schedule this work accordingly.
- B. Priority of right of way in space shall be as follows, in decreasing order of authority:
 1. Electrical lights, electrical panels and drain piping.
 2. Ductwork.
 3. Fire protection piping, domestic hot water, domestic cold water and condenser water piping.
- C. Any work done without regard for other trades shall be moved, replaced, or redone as required, without extra charges to Owner.

1.09 VERIFICATION OF EXISTING CONDITIONS AND DEMOLITION

- A. Before installation of any new work, verify the location, size and other conditions at all points of connection to services or other existing piping, and at all locations where new work will cross or pass near existing piping, electrical, or other facilities.
- B. Information shown relative to existing services is based upon available records and data during preparation of the Drawings, but shall be verified. Make reasonable deviations found necessary to conform with actual locations and conditions, without extra charge.
- C. Remove piping, controls, fixtures, and equipment that is not to remain in service as shown on the Drawings or as required. This includes the removal of associated appurtenances and supports.
- D. Patch, cap, or repair existing works affected by this demolition in concealed spaces within 6" of

a live main or branch.

- E. Deliver removed material to the Owner as directed by the Architect. Dispose of all other removed material offsite.

1.10 ACCURACY OF DATA

- A. The data given herein and on the Drawings is as exact as could be reasonably secured, but absolute accuracy is not guaranteed. Exact locations, distances, elevations, etc. will be governed by shop drawings, the building itself, and actual field conditions.

1.11 UTILITY CONNECTIONS

- A. Arrange for all utility connections, determine their exact requirements, and pay all costs incurred.
- B. Send proper notices, make necessary arrangements, and perform other services required for care and maintenance of all utilities and assume all responsibility concerning same. Observe all rules and regulations of the respective utilities in executing the work.

1.12 DAMAGE BY LEAKS

- A. Contractor shall be responsible for any damage to work of other Contractors that is caused by leaks in any temporary or permanent piping systems due to pipe rupture, disconnected pipes or fittings, or by overflow of equipment.

PART 2 PRODUCTS

2.01 PRODUCTS CRITERIA

- A. All materials, appliances, and equipment shall be new and best of their respective kinds, free from defects, and of the make, brand or quality specified or as accepted by the Architect.
- B. Multiple Units: When two or more units of materials or equipment of the same type or class are required, these units shall be products of one manufacturer.
- C. Apply and install all items in accordance with the manufacturer's written instructions. Refer conflicts between the manufacturer's instructions and the contract drawings and specifications to the Architect for resolution.
- D. All fixtures, materials, and equipment equal in quality and utility to these herein mentioned will be accepted. When specific names are used in describing fixtures, materials, and equipment they are mentioned as standards only, but this implies no right on the part of the Contractor to use other fixtures, materials and equipment, or methods, unless approved as equal in quality and utility by the Architect. The decision of the Architect shall govern as to what fixtures, materials, and equipment are equals to those mentioned, but the burden of proof as to the quality of any proposed fixtures, materials, or equipment shall be upon the Contractor. If any tests are necessary to determine the quality of proposed fixtures, materials, or equipment, an unbiased laboratory shall make such tests at the expense of the Contractor satisfactory to the Architect.

2.02 HANGERS, SUPPORTS

- A. Pipe supports shall be manufactured by Thomas & Betts, "Superstrut" or equivalent Cooper B-Line/Tolco, Nibco, or Anvil.
- B. All hangers shall be electro-chromate finished. Hanger rods shall have electro-galvanized

finish.

- C. Copper tubing:
 - 1. C-711 copper tube hanger, complete with C-716 isolator.
 - 2. Copper pipe shall be attached to channels with A-716 "Cush-A-Clamp".
- D. Insulated pipe:
 - 1. C-711 pipe hanger fitted to outside of insulation with C-790 galvanized shields.
- E. Trapeze hangers:
 - 1. Grouped pipes may be supported by A-1200 channel bolted to rods.
- F. Point of support connectors:
 - 1. Wood construction:
 - a. Stationary pipes: 540 side beam hanger
 - b. Pipes subject to movement: S541
 - 2. New concrete construction: 452 inserts.
 - 3. Existing concrete construction: Phillips "Red-Head" 3-piece concrete anchors or Hilti "Quik-Bolt", drilled-in, concrete anchors.
 - 4. Steel beams: Series 500 beam brackets.
 - 5. Plywood decks: machine bolts, nuts and washers.
- G. Vertical pipe risers:
 - 1. Vertical pipe risers shall be securely supported with C-720 pipe clamps anchored to construction.
 - 2. C-720P for bare cold water pipe, anchored to construction.
- H. Insulated pipe supports: K.B. Enterprises "Snapp Itz".
- I. Pipes through studs or joists shall be isolated from structure with properly sized Hubbard "Hold-Rite" suspension clamps or LSP "Acousto-Plumb" system.
- J. Ductwork
 - 1. Hanger Rods for Noncorrosive Environments: Cadmium-plated steel rods and nuts.
 - 2. Hanger Rods for Corrosive Environments: Electrogalvanized, all-thread rods or galvanized rods with threads painted with zinc-chromate primer after installation.
 - 3. Strap and Rod Sizes: Comply with SMACNA's "HVAC Duct Construction Standards - Metal and Flexible," Table 5-1, "Rectangular Duct Hangers Minimum Size," and Table 5-2, "Minimum Hanger Sizes for Round Duct."
 - 4. Steel Cable End Connections: Cadmium-plated steel assemblies with brackets, swivel, and bolts designed for duct hanger service; with an automatic-locking and clamping device.
 - 5. Duct Attachments: Sheet metal screws, blind rivets, or self-tapping metal screws; compatible with duct materials.
 - 6. Trapeze and Riser Supports:
 - a. Supports for Galvanized-Steel Ducts: Galvanized-steel shapes and plates.
 - b. Supports for Stainless-Steel Ducts: Stainless-steel shapes and plates.
 - c. Supports for Aluminum Ducts: Aluminum or galvanized steel coated with zinc chromate.

2.03 PIPE LABELS

- A. Brady, Seton or approved equal pipe labels. Preprinted, color-coded, with lettering indicating service, and showing flow direction.
- B. Self-Adhesive Pipe Labels: Printed plastic with contact-type, permanent-adhesive backing.

- C. Pipe Label Contents: Include identification of piping service using same designations or abbreviations as used on Drawings, pipe size, and an arrow indicating flow direction.
- D. Flow-Direction Arrows: Integral with piping system service lettering to accommodate both directions, or as separate unit on each pipe label to indicate flow direction.
- E. Label Sizes (per ANSI A13.1 / ASME A13.1-2007 Standards):
 - 1. For pipes or covering with outside diameter $\frac{3}{4}$ to $1\frac{1}{4}$ inches, minimum length of label: 8 inches, minimum height of letters: $\frac{1}{2}$ inch.
 - 2. For pipes or covering with outside diameter $1\frac{1}{2}$ to 2 inches, minimum length of label: 8 inches, minimum height of letters: $\frac{3}{4}$ inch.
 - 3. For pipes or covering with outside diameter $2\frac{1}{2}$ to 6 inches, minimum length of label: 12 inches, minimum height of letters: $1\frac{1}{4}$ inch.
 - 4. For pipes or covering with outside diameter 8 to 10 inches, minimum length of label: 24 inches, minimum height of letters: $2\frac{1}{2}$ inches.
 - 5. For pipes or covering with outside diameter over 10 inches, minimum length of label: 32 inches, minimum height of letters: $3\frac{1}{2}$ inches.

2.04 ELECTRICAL MOTORS

- A. With exception of motors in UL labeled equipment, motors for HVAC blowers and fans, pumps, and other general purpose applications using an adjustable speed drive shall be Baldor Premium Efficient Super-E®, three phase, foot mounted, Class H insulated motor with AEGIS shaft grounding ring installed internally, regreasable ball bearings, dynamically balanced rotors.
- B. Motors shall be certified for quiet operation and shall bear a label so stating. Motors shall be drip-proof frame, 1.15 minimum service factor in 40°C , ambient windings specially impregnated and epoxy coated for outdoor service.
- C. Torque characteristics of motors shall be as required to accelerate machine to 100% full load speed within 10 seconds. Motors shall be dynamically balanced to maximum deflection as follows:
 - 1. 15 HP and larger: 0.0003 inches.
 - 2. 10 HP and smaller: 0.0002 inches.
- D. Motors shall be Inverter duty, meet NEMA MG-1 and part 30 and 31, and shall be guaranteed to satisfactorily operate at $\pm 10\%$ voltage shown on Drawings. Transformers of adequate capacity shall be provided if necessary to satisfy this requirement.
- E. All 3-phase motors shall be provided with phase and brown-out protection to shut down all motors in the unit if the phases are more than 10% out of balance on voltage or the voltage is more than 10% under design voltage.
- F. Fractional horsepower fan motors ($\frac{1}{4}$ hp, $\frac{1}{2}$ hp, $\frac{3}{4}$ hp) shall be Greenheck "Vari-Green" series motors, DC electronic commutation type, specifically designed for fan applications. Motors shall be permanently lubricated with heavy duty ball bearings to match the fan load and pre-wired to the specific voltage and phase. Internal motor circuitry shall convert AC power supplied to the fan to DC power to operate the motor. Motor shall be controllable down to 20% of full speed (80% turndown). Speed shall be controlled by either a potentiometer dial mounted at the motor or by a 0-10 VDC signal. Motor shall be a minimum of 85% efficient at all speeds.
- G. Provide fan drives rated at 150% of motor horsepower. Drives shall be adjustable sheave type unless specified otherwise. Listed fan speeds are only approximate; select and/or change drives to operate at approximately midpoint of adjustable range after final balancing.

PART 3 EXECUTION

3.01 INSTALLATION, GENERAL

- A. Provide all necessary sleeving, core drilling, carpentry, cutting and patching required for proper installation of material and equipment specified.
- B. No structural members shall be drilled, bored, or notched in a manner that will impair their structural capacity. No structural cutting or drilling shall be done without the approval of the Architect.
- C. All penetrations of concrete or masonry shall be made with core drills. Verify location of all core drills with structural engineer prior to execution.

3.02 EQUIPMENT

- A. Equipment shall operate quietly and without objectionable vibration. Such problems, other than from equipment operating at optimum conditions, shall be the Contractor's responsibility and shall be eliminated at the direction of the Architect.
- B. Install equipment to provide good appearance, easy access, and adequate space to allow replacement and maintenance. Provide bases, supports, anchor bolts, and other items required to achieve this. Installation shall be level, above moisture level, and adequately braced.
- C. Extend ¼" schedule 40 black steel lubrication pipes from hard-to-reach locations to front of equipment or to access doors. Terminate with proper lubrication fittings.
- D. Move equipment into building through available openings. Dismantle equipment where necessary to accomplish this. After reassembly, test equipment to verify its satisfactory operating condition.
- E. Thoroughly lubricate equipment before operating. Repair of damage resulting from failure to comply with this requirement shall be the Contractor's responsibility.
- F. Connections to piping shall be secured and properly aligned and all utility and control connections shall be properly isolated from the building structure by means of vibration isolators and flexible connections. Any equipment not meeting this requirement will be modified and properly reinstalled at no expense to the Owner.

3.03 ACCESS

- A. All items that require access, such as for operating, cleaning, servicing, maintenance, and calibration shall be easily and safely accessible by persons standing at floor level, or standing on permanent platforms, without the use of portable ladders. Examples of these items include, but are not limited to: all types of valves, filters and strainers, transmitters and control devices. Prior to commencing installation work, refer conflicts between this requirement and contract Drawings to Architect for resolution.

3.04 MECHANICAL SERVICES

- A. Terminals and services weighing no more than 20 pounds, may be supported directly on the runners of a heavy duty grid system but, in addition, they must have a minimum of (2) #12 gage slack safety wires attached at diagonally opposite corners and anchored to the structure above.

3.05 CONCRETE EQUIPMENT BASES

- A. Concrete work that is part of the mechanical installations, as such is shown and/or detailed on

the Drawings, shall conform to the requirements of the Concrete Section of these Specifications.

- B. Concrete bases: Anchor equipment to concrete base according to equipment details on mechanical and structural Drawings.
- C. Bases shall be neatly finished, have rounded corners and smooth trowel finish.

3.06 ELECTRICAL REQUIREMENTS

- A. Electrical work in this Section shall conform to the requirements of Division 26. Equipment shall conform to the standards of the National Electric Manufacturer's Association. Electrical equipment shall bear the label of Underwriters' Laboratories, Inc., where examination and listing service is available for such materials. Motors and motor control equipment shall be as specified below.
 - 1. The work shall include the furnishing of:
 - a. Motor controls mounted as integral part of equipment assemblies.
 - b. Pre-wired control panels as described and shown.
 - c. Electronic control panels and their components.
 - d. Wiring for low voltage controls and "interlock work" except where specifically shown otherwise.
 - 2. Installing of:
 - a. All motors.
 - b. All control panels and their components.
 - c. Low voltage wiring, line voltage "interlock" wiring, control wiring for safety devices, alarms, and refrigeration.
- B. Wiring includes all connections to devices, and all wiring shall be installed in conduit.
 - 1. Conduit fittings and devices shall be as specified in the basic electrical materials section of Division 26 - Electrical.
 - 2. Line voltage work (in equipment assemblies) shall be as specified in Division 26 - Electrical.
 - 3. Devices shall be installed in NEMA enclosures of type required for location.
 - a. Flush enclosures: Keystone "Telephone Cabinets" type PF with pull box knockouts.
 - b. Surface enclosures: Keystone LJC.
- C. Electrical Controls:
 - 1. Submit shop-wiring diagrams of temperature controls and air conditioning unit controls for approval. Furnish approved wiring diagrams and assistance to Electrician.
 - 2. Refer to Electrical, Fire Protection, Plumbing and Mechanical documents for work and devices required. All wiring required by plumbing and heating, ventilating and air conditioning work shall be performed by the Controls Contractor.
- D. The following work will be furnished and installed under Division 26.
 - 1. Disconnect switches, remote switches, motor starters, relays and test switches not mounted as integral part of equipment assemblies or in temperature control panels.
 - 2. All line voltage controls and interlocks, all other controls, circuits from electric panel board to disconnect switches, starters, motors, switches and/or other motor controls, to temperature controls and safety devices.

3.07 PAINTING

- A. Properly prepare work to be painted per the requirements of Division 09, except preservative and special painting as described herein. Priming shall conform to Division 09 requirements and be of a material compatible with paint for finish painting.
- B. All equipment and materials shall be cleaned of grease, wax, oil, rust or dirt in preparation for

finish painting. Any prime coated surfaces showing signs of rust before being finish painted shall be thoroughly cleaned and a new prime coat applied.

- C. Prime paint both sides of flashings prior to installation.
- D. Furnish can of touch-up paint with each factory finished piece of equipment.
- E. Paint all piping in mechanical rooms. Color as selected by the Architect.
- F. Black steel piping exposed to the environment shall be painted with rust-inhibiting paint. Color as selected by Architect.

3.08 IDENTIFICATION OF SYSTEMS

- A. Nameplates
 - 1. Nameplate bearing manufacturer's name or identifiable trademark shall be securely affixed in a conspicuous place on equipment, or name or trademark cast integrally with equipment, stamped or otherwise permanently marked on each item of equipment.
- B. Piping
 - 1. Locate pipe labels where piping is exposed or above accessible ceilings in finished spaces; machine rooms; accessible maintenance spaces such as shafts, tunnels, and plenums; and exterior exposed locations as follows:
 - a. Adjacent to all valves and flanges
 - b. Near each branch connection, excluding short takeoffs for fixtures and terminal units. Where flow pattern is not obvious, mark each pipe at branch.
 - c. At both sides of wall or floor penetrations.
 - d. Before and after all wall, floor and ceiling penetrations and inaccessible enclosures.
 - e. Adjacent to changes in direction.
 - f. At access doors, manholes, and similar access points that permit view of concealed piping.
 - g. Near major equipment items and other points of origination and termination.
 - h. Spaced at maximum intervals of 25 feet along each run. Reduce intervals in areas of congested piping and equipment.
 - i. On piping above removable acoustical ceilings. Omit intermediately spaced labels.
 - 2. All piping shall be identified.
 - 3. Pipe Label Color Schedule: (per ANSI A13.1 / ASME A13.1)
 - a. Potable, Cooling, Boiler Feed and other Water Piping:
 - 1) Background Color: Green.
 - 2) Letter Color: White.
 - b. Fire Quenching Fluids:
 - 1) Background Color: Red.
 - 2) Letter Color: White.
 - c. Toxic and Corrosive Fluids
 - 1) Background Color: Orange.
 - 2) Letter Color: Black
 - d. Flammable Fluids:
 - 1) Background Color: Yellow.
 - 2) Letter Color: Black.
 - e. Combustible Fluids:
 - 1) Background Color: Brown.
 - 2) Letter Color: White
- C. Valves
 - 1. For identification and Owner's maintenance records, all valves shall be numbered and

- identified with clearly stamped 1¼" diameter brass tags, in accordance with drawings and service performed.
2. Control valves shall be also marked whether normally open (N.O.) or normally closed (N.S.).
- D. Equipment
1. All equipment shall be labeled with 1" high stencils showing identifying mark noted on drawings, and usage.
 2. Warning signs shall be placed on machines driven by electrical motors that are controlled by fully automatic starters, per California Code of Regulations, Title 8, Subchapter 7 - General Industry Safety Orders, Article 7, Section 3320.
- E. A typewritten schedule of all stencils and valve tags used, with identification, shall be framed and posted in mechanical rooms, at locations as directed.

3.09 INSTALLATION, HANGERS AND SUPPORTS

- A. Pipe supports shall be spaced according to CPC 2016, Table 313.3 and sufficiently close to support pipes properly without formation of pockets. Hangers shall be installed at ends of mains and branches.
- B. Install hangers and supports complete with necessary attachments, inserts, bolts, rods, nuts, washers, and other accessories.
- C. Suspended water piping shall be anchored with steel struts installed at midpoint of each run.
- D. No valve or piece of equipment shall be used to support piping.
- E. Install hangers and supports to allow controlled thermal and seismic movement of piping systems, to permit freedom of movement between pipe anchors, and to facilitate action of expansion joints, expansion loops, expansion bends, and similar units.
- F. Flexibility of piping systems must be maintained by the use of flexible devices at critical points at junctions of separate building structures. Braces or anchors shall be designed to damp oscillations or check excessive movement. Flexible devices for piping of gas shall be loops or offsets. Flexible devices for other piping may be loops, Victaulic grooved, or roustabout couplings.
- G. Piping at tops and bottoms of risers are critical points where flexibility is required, as well as at changes in direction on long runs of piping 4" and larger.
- H. Tops of risers shall be restrained from motion in horizontal direction, and midpoints shall be anchored in all directions.
- I. Install lateral bracing with pipe hangers and supports to prevent swaying. The following table shows maximum lengths of shapes used for sway bracing:

| TYPE/SIZE | MAX. LENGTH | TYPE/SIZE | MAX. LENGTH |
|--------------|-------------|-----------|-------------|
| Angle | (1/r=200) | Flat Bar | (1/r=200) |
| 1½ x 1½ x ¼" | 4'-10" | 1½ x ¼" | 1'-2" |
| 2 x 2 x ¼" | 6'-6" | 2 x ¼" | 1'-2" |
| 2½ x 2½ x ¼" | 8'-2" | 2 x ⅜" | 1'-9" |
| 3 x 3 x ¼" | 9'-10" | | |

| Threaded Rod | | Pipe (Schedule 40) | |
|--------------|-------|--------------------|--------|
| 3/8" | 1'-7" | 1" | 7'-0" |
| 1/2" | 2'-1" | 1 1/4" | 9'-0" |
| 5/8" | 2'-7" | 1 1/2" | 10'-4" |
| 3/4" | 3'-1" | 2" | 13'-1" |
| 1" | 4'-2" | | |

- J. Install building attachments within concrete slabs or attach to structural steel. Install additional attachments at concentrated loads, including valves, flanges, and strainers, 2-1/2 inches and larger and at changes in direction of piping. Install concrete inserts before concrete is placed; fasten inserts to forms and install reinforcing bars through openings at top of inserts.
- K. Metal Pipe-hanger Installation: Install hangers, supports, clamps, and attachments as required to properly support piping from the building structure.
- L. Metal Trapeze Pipe-Hanger Installation: Support together and space trapezes for smallest pipe size or install intermediate supports for smaller diameter pipes as specified for individual pipe hangers.
- M. Thermal-Hanger Shield Installation: Install in pipe hanger or shield for insulated piping.
- N. Load Distribution: Install hangers and supports so that piping live and dead loads and stresses from movement will not be transmitted to connected equipment.
- O. Pipe Slopes: Install hangers and supports to provide indicated pipe slopes and to not exceed maximum pipe deflections allowed by ASME B31.9 for building services piping.
- P. Insulated Piping:
 - 1. Attach clamps and spacers to piping.
 - a. Piping Operating above Ambient Air Temperature: Clamp may project through insulation.
 - b. Piping Operating below Ambient Air Temperature: Use thermal-hanger shield insert with clamp sized to match OD of insert.
 - c. Do not exceed pipe stress limits allowed by ASME B31.9 for building services piping.

3.10 PIPE WELDING

- A. All hot and chilled water, steam and steam condensate, compressed air and vacuum piping shall be installed, examined, inspected and tested in accordance with the requirements of ASME B31.9, Building Services Piping, current edition.
- B. Weld all pipe 2.5 inches and larger. Use the following procedure. All welders must be AWS certified. AWS B2.1 SMAW 6G Pipe Welding Procedure Specifications

| | |
|-----------------------------|--|
| Welding process: SMAW | Grove Angle: 60 degrees |
| Position: 6G Fixed position | Material/Spec: A 106 |
| Weld Progression: Up | Thickness (pipe/tube): Groove (in) .280 |
| Backing: No | Notes: Sch. 40 Pipe |
| Current/Polarity: DCEP | Filler Metal Class: E6010Rt/E7018F1 |
| Root Opening: 1/16 to 1/8 | Other Filler Metal Class: Rt. 1/8, 3/32 Filler |
- C. Welded joints shall be beveled and butt-welded. Reductions of pipe shall be made with forged steel welding fittings. Branch reductions of two or more pipe sizes smaller than the main, may be Bonney "Weld-O-Let" fittings, or equal. Job fabricated reductions and branches shall not be used.

All pipe burrs shall be reamed out. Welding rods shall be as follows, or approved equal:

| <u>Pipe Size</u> | <u>Arc Welding</u> | <u>Gas Welding</u> |
|------------------|--------------------|-----------------------------|
| 2" and larger | Fleetweld #5 | Oxweld #1 or Page Hi-Test M |
| 1½" and smaller | None | Oxweld #1 or Page Hi-Test M |

3.11 INSTALLATION, PIPING

- A. Installation of piping shall be such that damage cannot result through thermal expansion or contraction, to piping, building, or pipe hangers and supports. Anchors shall be installed at midpoints of all runs in main piping for the purpose of localizing pipe expansion or prevention of creepage.
- B. All piping shall be concealed in finished rooms, installed in furred walls and partitions. Where furred or suspended ceilings occur, piping shall be installed in the concealed space at points adjacent to beams and/or other structural members, and coordinated with ductwork and equipment. Where exposed piping occurs, it shall be installed parallel to or at right angles to building walls, unless specifically shown otherwise on the Drawings.
- C. All pipe lines shall be installed free from traps and air pockets, true to line and grade, with suitable supports properly spaced. All piping shall be installed without undue stresses and with provision for expansion and contraction.
- D. All piping shall be new and free from foreign substances. American standard pipe threads shall be used for IPS threaded work. Joints in threaded piping shall be made up with Teflon tape applied to the male threads only. No screwed pipe joints shall be caulked or packed with rope or other packing materials. Pipe shall be free from tool marks, threads cut accurately with not more than 2 threads showing beyond fitting. Friction wrenches shall not be used with plated, polished, or soft metal piping. All changes in pipe size shall be made with reducing fitting. Bushings will not be permitted.
- E. Protect unattended openings in piping during construction.
- F. All copper tubing shall be formed in a workmanlike manner, in accordance with the Pipe and Tube Bending Handbook of the Copper and Brass Research Association. A tube bender giving support to the periphery of the tube shall be used. The tubing shall be protected against flattening or other injury.
- G. All copper connections and joints shall be made in accordance with the Copper Tube Handbook, Copper and Brass Research Association. No swaged connections will be permitted. All valves, pumps, and similar equipment shall be connected to copper piping through union or flange adapter fittings.
- H. All underground hydronic piping shall be installed per manufacturer's installation instructions. Provide protection of piping from damage due to expansion. Provide thrust blocks where required as indicated by the manufacturers installation instructions.
- I. No water or drainage piping shall pass over electrical equipment unless adequate protection is provided to prevent damage by leaks or condensation.
- J. Install air vents at all water piping high points when direction of flow is downward.
- K. Install sediment drain faucets at all low points.
- L. Valves, cocks, etc., shall be installed to allow convenient accessibility and operation.
- M. Unions and flanges shall be installed to allow convenient replacement of all equipment and cleaning tubes.

- N. A union connection shall be installed downstream from all valves, at equipment connections and at other locations as required or directed.
- O. Shut off valves shall be provided in all main services, and where required to permit proper servicing of equipment. Valves of one type shall be of one manufacturer.
- P. All valves shall be of the same size as the pipelines in which they are installed, unless specifically sized on the Drawings. All hand controlled line valves shall be ball valves, except where throttling control or frequent operation is required, in which case globe or angle valves shall be used. Globe valves in horizontal lines shall be installed with stem in horizontal to permit line draining. All globe and angle valves shall be installed to close against pressure. Disc valves shall have discs suitable for the services for which they are to be used.
- Q. All valves shall be accessible and shall not be installed with the stems below the horizontal plane. Provide access panels at walls, ceilings, or floors.
- R. Provide prime coated escutcheon plates at all points where exposed piping penetrates finished wall ceilings or floors.
- S. Cutting or boring of joists or other structural members shall be done only when alternative routing is impossible and only upon written approval of the Architect or Owner.

3.12 CLEANING OF PIPING

- A. All new piping shall be thoroughly cleaned of rust, scale, etc., prior to enclosing and placing in operation. Water shall be forced through pipes until the systems are free from foreign substances.

3.13 CLEANUP

- A. Upon completion of the work of this Section, remove all material, debris, and equipment associated with or used in the performance of this work.

END OF SECTION

SECTION 23 0593

TESTING, ADJUSTING, AND BALANCING FOR HVAC

PART 1 - GENERAL

1.01 RELATED DOCUMENTS

- A. Drawings and general provisions of the Contract, including General and Supplementary Conditions and Division 01 Specification Sections, apply to this Section.

1.02 SUMMARY

- A. Section Includes:
 - 1. Balancing Air Systems
 - 2. Additional Tests
 - a. Duct leakage testing
 - b. Controls verification

1.03 SCOPE

- A. The T&B Agency will provide the following services:
 - 1. Provide all supervision, personnel, instruments, calibration equipment, and all other materials necessary to perform balancing and testing, and compile test data including calculations and services necessary for the heating, ventilating, and air conditioning systems for this project, all in accordance with the project Drawings and Specifications and as specified herein.
 - 2. The T&B Agency shall be responsible for inspecting, balancing, adjusting, testing, and logging the data of the performance of fans, all dampers in the duct systems, all air distribution devices or heat exchangers, and the flows of water through all coils.
 - 3. The T&B Agency shall balance, test, and adjust the systemic components to obtain optimum conditions in each conditioned space in the building. If construction deficiencies are encountered which preclude obtaining optimum conditions, the deficiencies will be recorded and given to the Owner's Representative. The T&B Agency is advised that deficiencies in the HVAC construction are often encountered during final T&B services, and should include in the bid an amount deemed advisable to compensate for time in identifying the deficiencies.
- B. During construction, the T&B Contractor shall inspect the installation of pipe systems, sheet metal work, temperature controls, and other component parts of the HVAC systems. Inspections shall be conducted a minimum of three times. Typically this is performed when 60% of the ductwork and piping are installed and again when 90% of the total system is installed and prior to insulation. A copy of the written report is to be issued to the Mechanical Engineer for review.

1.04 SUBMITTALS

- A. Strategies and Procedures Plan: Within 30 days of Contractor's Notice to Proceed, submit T&B strategies and step-by-step procedures.
- B. System Readiness Checklists: Within 30 days of Contractor's Notice to Proceed, submit system readiness checklists for use by systems installers in verifying system readiness for T&B.
Examination Report: Within 30 days of Contractor's Notice to Proceed, provide a summary report

of the examination review required in Part 3 "Examination", if issues are discovered that may preclude the proper testing and balancing of the systems.

- C. Examination Report: Provide a summary report of the examination review if issues are discovered that may preclude the proper testing and balancing of the systems.
- D. Certified T&B reports: Within 30 days of completion of balancing work, submit AABC-certified T&B report.
 - 1. Submit one copy of the final T&B Report directly to the design professional of record. Provide three additional copies to the contractor.

1.05 QUALITY ASSURANCE

- A. T&B Contractor Qualifications:
 - 1. General Contractor will employ a T&B Agency that is certified by the Associated Air Balancing Council (AABC). The T&B Agency will have experience in the field of air system balancing, possess calibrated instruments, and employ qualified Supervisors and skilled Technicians to perform all required tests. The T&B Agency shall have a minimum of ten years experience in the Testing, Adjusting, and Balancing field.
- B. T&B technician shall perform the following:
 - 1. Review field data reports to validate accuracy of data and to prepare certified T&B reports.
 - 2. Certify that the T&B team complied with the approved T&B plan and the procedures specified and referenced in this Specification.
 - 3. Certify the T&B report
- C. T&B Conference: If requested by the Owner or Construction Manager after approval of the T&B Agency's submittals, meet to develop a mutual understanding of the details
 - 1. Agenda Items:
 - a. The examination report.
 - b. The Strategies and Procedures plan.
 - c. Systems readiness checklists.
 - d. Coordination and cooperation of trades and subcontractors.
 - e. Coordination of documentation and communication flow.
- D. Approved Test and Balance agencies in the area:

RS Analysis, Inc.
1035 Suncast Lane, Suite 130
El Dorado Hills, CA 95762
(916) 358-5672

National Air Balance Company, Inc.
4171 Business Center Drive
Fremont, CA 94538
(510) 623-7000

Raglen System Balance, Inc.
1121 University Terrace
Reno, NV 89502
(775) 747-0100

Pacific Test & Balance, Inc.
4771 Mangels Blvd.
Fairfield, CA 94534
(707) 696-2444

- E. T&B Report Forms: Use standard T&B contractor's forms.
- F. Instrumentation Type, Quantity, Accuracy, and Calibration: As described in "AABC National Standards for Total Systems Balance."

PART 2 - PRODUCTS (NOT USED)

PART 3 - EXECUTION

3.01 CONTRACTOR RESPONSIBILITIES

- A. Provide T&B agency one complete set of contract documents, change orders, and approved submittals in digital and hard copy formats. Project Schedule and Mechanical Contractor's Shop Drawings and Temperature Control Drawings shall be provided as issued or received.
- B. Controls contractor shall provide required BAS hardware, software, personnel and assistance to T&B agency as required to balance the systems. Controls contractor shall also provide trending report to demonstrate that systems are complete.
- C. Coordinate meetings and assistance from suppliers and contractors as required by T&B agency.
- D. Provide additional valves, dampers, sheaves and belts to properly test and balance, which shall be installed by the Mechanical Contractor as directed by T&B agency, at no additional cost to owner.
- E. Mechanical Contractor shall install test holes where indicated by the T&B Agency. Test holes shall be complete with removable and replaceable plugs
- F. Flag all manual volume dampers with fluorescent or other high-visibility tape.
- G. Provide access to all dampers, valves, test ports, nameplates and other appurtenances as required by T&B agency.
- H. Replace or repair insulation as required by T&B agency.
- I. Have the HVAC systems at complete operational readiness for T&B to begin. As a minimum verify the following:
 - 1. Airside:
 - a. All ductwork is complete with all terminals installed.
 - b. All volume, smoke and fire dampers are open and functional.
 - c. Clean filters are installed.
 - d. All fans are operating, free of vibration, and rotating in correct direction.
 - e. VFD start-up is complete and all safeties are verified.
 - f. System readiness checklists are completed and returned to T&B agency.
- J. Promptly correct deficiencies identified during T&B.
- K. Maintain a construction schedule that allows the T&B agency to complete work prior to occupancy.
- L. Before testing or balancing is started, the Mechanical Contractor shall adjust belts and sheaves; align all parts; oil and grease bearings in accordance with manufacturer's instructions; clean

exterior surfaces of coil tubes and fins; flush interior of coil tubes, pull until clean; and check mixing damper operation to insure free operation and activation by the correct thermostat

- M. The Mechanical Contractor shall be responsible for certifying in writing that the system, as scheduled for balancing, is operational and complete. Completeness shall include not only the physical installation, but the Mechanical Contractor's certification that the prime movers are installed in good working order, and that full load performance has been preliminary tested under the certification of the Mechanical Contractor. Before any testing and balancing is started, a complete report shall be sent to the T&B Agency by the Mechanical Contractor.
- N. The Mechanical Contractor shall be responsible for making all modifications to rectify discrepancies reported by the T&B Contractor as indicating non-compliance with the Contract Documents. By completing the work on time, the Mechanical Contractor shall provide sufficient time before the completion date so that balancing can be accomplished.

3.02 EXAMINATION & REVIEW

- A. Review the Contractor shop drawing submittals for their effect on the test and balance process and overall performance of the HVAC system. Submit recommendations for enhancements or changes to the system.
- B. Review location and type of volume damper inlet conditions to air terminals, air valves, and HVAC equipment.
- C. Review location, type, and size of balancing valves, flow metering stations, and automatic control valves in the water flow station.
- D. Review location of pressure sensors in the air and water distribution system.
- E. Review automatic control systems as they affect the test and balance procedure.
- F. Review sheet metal and piping shop drawings to verify the installation of flow control devices.
- G. Examine systems for installed balancing devices, such as test ports, gage cocks, thermometer wells, flow-control devices, balancing valves and fittings, and manual volume dampers. Note the locations of devices that are not accessible for testing and balancing.
- H. Review the approved submittals for HVAC systems and equipment.
- I. Examine ceiling plenums and underfloor air plenums used for supply, return, or relief air to verify that they are properly separated from adjacent areas.
- J. Review equipment performance data including fan and pump curves.
- K. Examine HVAC equipment and verify that bearings are greased, belts are aligned and tight, clean permanent filters are installed, and controls are ready for operation.
- L. Examine terminal units, such as variable-air-volume boxes, and verify that they are accessible and their controls are connected, configured by the controls contractor and functioning.
- M. Examine strainers to verify that Mechanical Contractor has replaced startup screens with permanent screens and that all strainers have been cleaned.
- N. Examine two-way valves for proper installation and function.
- O. Examine three-way valves for proper installation for their intended function of diverting or mixing fluid flows.
- P. Examine heat-transfer coils for correct piping connections and for clean and straight fins.

3.03 PREPARATION

- A. Prepare a T&B plan that includes:
 - 1. Equipment and systems to be tested.
 - 2. Strategies and step-by-step procedures for balancing the systems.
 - 3. Instrumentation to be used.
 - 4. Sample forms with specific identification for all equipment.
- B. Prepare system-readiness checklists, as described in the *AABC National Standards for Total System Balance*, for use by contractors in verifying system readiness for T&B. These shall include, at a minimum:
 - 1. Airside:
 - a. All ductwork is complete with all terminals installed.
 - b. All volume, smoke and fire dampers are open and functional.
 - c. Clean filters are installed.
 - d. All fans are operating, free of vibration, and rotating in correct direction.
 - e. VFD start-up is complete and all safeties are verified.
 - f. Automatic temperature-control systems are operational.
 - g. Ceilings are installed.
 - h. Windows and doors are installed.
 - i. Suitable access to balancing devices and equipment is provided.

3.04 GENERAL PROCEDURES FOR TESTING AND BALANCING

- A. Perform testing and balancing procedures on each system according to the procedures contained in AABC's "National Standards for Total System Balance" and in this Section.
- B. Cut insulation, ducts, pipes, and equipment cabinets for installation of test probes to the minimum extent necessary for T&B procedures.
- C. Mark equipment and balancing devices, including damper-control positions, valve position indicators, fan-speed-control levers, and similar controls and devices, with paint or other suitable, permanent identification material to show final settings.
- D. Take and report testing and balancing measurements in inch-pound (IP) units.

3.05 GENERAL PROCEDURES FOR BALANCING AIR SYSTEMS

- A. Prepare test reports for both fans and outlets. Obtain approved submittals and recommended testing procedures. Crosscheck the summation of required outlet volumes with required fan volumes.
- B. Prepare single-line schematic diagram of systems for the purpose of identifying HVAC components.
- C. For variable-air-volume systems, develop a plan to simulate diversity.
- D. Determine the best locations in main and branch ducts for accurate duct-airflow measurements.
- E. Locate start-stop and disconnect switches, electrical interlocks, and motor starters.
- F. Verify that motor starters are equipped with properly sized thermal protection.
- G. Check condensate drains for proper connections and functioning.

- H. Check for proper sealing of air-handling-unit components.

3.06 PROCEDURES FOR CONSTANT-VOLUME AIR SYSTEMS

- A. Adjust fans to deliver total indicated airflows within the maximum allowable fan speed listed by fan manufacturer.
 - 1. Measure total airflow.
 - a. Set outside air, return air and relief air dampers for proper position that simulates minimum outdoor air conditions.
 - b. Where duct conditions allow, measure airflow by Pitot-tube traverse. If necessary, perform multiple Pitot-tube traverses to obtain total airflow.
 - c. Where duct conditions are not suitable for Pitot-tube traverse measurements, a coil traverse may be acceptable.
 - d. If a reliable Pitot-tube traverse or coil traverse is not possible, measure airflow at terminals and calculate the total airflow.
 - 2. Measure fan static pressures as follows:
 - a. Measure static pressure directly at the fan outlet or through the flexible connection.
 - b. Measure static pressure directly at the fan inlet or through the flexible connection.
 - c. Measure static pressure across each component that makes up the air-handling system.
 - d. Report any artificial loading of filters at the time static pressures are measured.
 - 3. Do not make fan-speed adjustments that result in motor overload. Consult equipment manufacturers about fan-speed safety factors. Modulate dampers and measure fan-motor amperage to ensure that no overload will occur. Measure amperage in full-cooling, full-heating, economizer, and any other operating mode to determine the maximum required brake horsepower.
- B. Adjust volume dampers for main duct, submain ducts, and major branch ducts to indicated airflows.
 - 1. Measure airflow of submain and branch ducts.
 - 2. Adjust sub-main and branch duct volume dampers for specified airflow. Re-measure each sub-main and branch duct after all have been adjusted.
- C. Adjust air inlets and outlets for each space to indicated airflows.
 - 1. Set airflow patterns of adjustable outlets for proper distribution without drafts.
 - 2. Measure airflow at all inlets and outlets.
 - 3. Adjust each inlet and outlet for specified airflow.
 - 4. Re-measure each inlet and outlet after all have been adjusted.
- D. Verify final system conditions.
 - 1. Re-measure and confirm minimum outdoor air, return and relief airflows are within design. Readjust to design if necessary.
 - 2. Re-measure and confirm total airflow is within design.
 - 3. Re-measure all final fan operating data, rpms, volts, amps, static profile.
 - 4. Mark all final settings.
 - 5. Test system in economizer mode. Verify proper operation and adjust, if necessary.

6. Measure and record all operating data.

E. Record final fan-performance data

3.07 PROCEDURES FOR VARIABLE-AIR-VOLUME SYSTEMS

A. Adjust the variable-air-volume systems as follows:

1. Verify that the system static pressure sensor is located 2/3 of the distance down the duct from the fan discharge.
2. Verify that the system is under static pressure control.
3. Select the terminal unit that is most critical to the supply-fan airflow. Measure inlet static pressure, and adjust system static pressure control setpoint so the entering static pressure for the critical terminal unit is not less than the sum of the terminal-unit manufacturer's recommended minimum inlet static pressure plus the static pressure needed to overcome terminal-unit discharge system losses.
4. Calibrate and balance each terminal unit for maximum and minimum design airflow as follows
 - a. Adjust controls so that terminal is calling for maximum airflow (note some controllers require starting with minimum airflow. Verify calibration procedure for specific project).
 - b. Measure airflow and adjust calibration factor as required for design maximum airflow. Record calibration factor.
 - c. When maximum airflow is correct, balance the air outlets downstream from terminal units.
 - d. Adjust controls so that terminal is calling for minimum airflow.
 - e. Measure airflow and adjust calibration factor as required for design minimum airflow. Record calibration factor. If no minimum calibration is available, note any deviation from design airflow.
 - f. When in full cooling or full heating, ensure that there is no mixing of hot deck and cold deck airstreams unless so designed.
 - g. On constant volume terminals, in critical areas where room pressure is to be maintained, verify that the airflow remains constant over the full range of full cooling to full heating. Note any deviation from design airflow or room pressure.
5. After all terminals have been calibrated and balanced, test and adjust system for total airflow. Adjust fans to deliver total design airflows within the maximum allowable fan speed listed by fan manufacturer.
 - a. Set outside air, return air and relief air dampers for proper position that simulates minimum outdoor air conditions.
 - b. Set terminals for maximum airflow. If system design includes diversity, adjust terminals for maximum and minimum airflow so that connected total matches fan selection and simulates actual load in the building.
 - c. Where duct conditions allow, measure airflow by Pitot-tube traverse. If necessary, perform multiple Pitot-tube traverses to obtain total airflow.
 - d. Where duct conditions are not suitable for Pitot-tube traverse measurements, a coil traverse may be acceptable.
 - e. If a reliable Pitot-tube traverse or coil traverse is not possible, measure airflow at terminals and calculate the total airflow.
6. Measure fan static pressures as follows:
 - a. Measure static pressure directly at the fan outlet or through the flexible connection.
 - b. Measure static pressure directly at the fan inlet or through the flexible connection.

- c. Measure static pressure across each component that makes up the air-handling system.
- d. Report any artificial loading of filters at the time static pressures are measured.
7. Set final return and outside airflow to the fan while operating at maximum return airflow and minimum outdoor airflow.
 - a. Balance the return-air ducts and inlets the same as described for constant-volume air systems.
 - b. Verify all terminal units are meeting design airflow under system maximum flow.
8. Re-measure the inlet static pressure at the most critical terminal unit and adjust the system static pressure setpoint to the most energy-efficient setpoint to maintain the optimum system static pressure. Record setpoint and give to controls contractor.
9. Verify final system conditions as follows:
 - a. Re-measure and confirm minimum outdoor air, return and relief airflows are within design. Readjust to design if necessary.
 - b. Re-measure and confirm total airflow is within design.
 - c. Re-measure all final fan operating data, rpms, volts, amps, static profile.
 - d. Mark all final settings.
 - e. Test system in economizer mode. Verify proper operation and adjust, if necessary. Measure and record all operating data.
 - f. Verify tracking between supply and return fans.

B. TOLERANCES

1. Set HVAC system's air flow rates and water flow rates within the following tolerances:
 - a. Supply, Return, and Exhaust Fans and Equipment with Fans: Plus or minus 10 percent.
 - b. Air Outlets and Inlets: Plus or minus 10 percent.
 - c. Heating-Water Flow Rate: Plus or minus 10 percent.
 - d. Cooling-Water Flow Rate: Plus or minus 10 percent.
- C. Maintaining pressure relationships as designed shall have priority over the tolerances specified above.

3.08 FINAL TEST AND BALANCE REPORT

- A. The report shall be a complete record of the HVAC system performance, including conditions of operation, items outstanding, and any deviations found during the T&B process. The final report also provides a reference of actual operating conditions for the owner and/or operations personnel. All measurements and test results that appear in the reports must be made on site and dated by the AABC technicians or test and balance engineers.
- B. The report must be organized by systems and shall include the following information as a minimum:
 1. Title Page:
 - a. AABC certified company name
 - b. Company address
 - c. Company telephone number
 - d. Project identification number
 - e. Location
 - f. Project Architect
 - g. Project Engineer
 - h. Project Contractor

- i. Project number
 - j. Date of report
 - k. AABC Certification Statement
 - l. Name, signature, and certification number of AABC TBE
2. Table of Contents.
 3. AABC National Performance Guaranty.
 4. Report Summary:
 - a. The summary shall include a list of items that do not meet design tolerances, with information that may be considered in resolving deficiencies.
 5. Instrument List:
 - a. Type.
 - b. Manufacturer.
 - c. Model.
 - d. Serial Number.
 - e. Calibration Date.
 6. T&B Data:
 - a. Provide test data for specific systems and equipment as required by the most recent edition of the "AABC National Standards."
 7. Print or sketch, reduced in size, showing all supply, return and exhaust air outlets for easy reference to report data.
- C. One copy of the final test and balance report shall be sent directly to the Mechanical Engineer of record. Provide five additional copies to the contractor.
- D. An approved copy of the balancing report shall be included in the maintenance manual submittal.

3.09 ADDITIONAL TESTS

- A. Duct Leakage Test
1. All ductwork shall be tested for leaks, using necessary instruments before insulating any ductwork. Conduct test as follows and as recommended in SMACNA Balancing Manual.
 - a. Seal all openings in duct section and plenum to be tested.
 - b. Connect test apparatus to test section of cuts, using a flexible duct connection or hose (fitting provided by Mechanical Contractor).
 - c. Close damper on blower suction side, to prevent excessive build-up of pressure.
 - d. Start blower and gradually open damper on suction side of blower.
 - e. Determine amount of air leakage and make repairs as required.
 - f. Leakage factor allowable shall be 5% based on the total operating cfm of the section of duct under testing.
 - g. Tested sections of ductwork shall be visually marked with certification sticker and initials of field test inspector. Tests shall be made before duct sections are concealed.
 2. Witness the duct pressure testing performed by the mechanical/installing contractor.
 3. Verify that proper test methods are used and that leakage rates are within specified tolerances.
 4. Report any deficiencies observed.
- B. Controls Verification

1. In conjunction with system balancing perform the following:
 - a. Work with the temperature control contractor to ensure the system is operating within the design limitations, and gain a mutual understanding of intended control performance.
 - b. Verify the integrity of valves and dampers in terms of tightness of close-off and full-open position. This includes dampers in multi-zone units.
 - c. Check that all valves are properly installed in the piping system in relation to direction of flow and location.
 - d. Verify the proper application of all normally open and normally closed valves.
 - e. Check the locations of all thermostats and humidistats for potential erratic operation from outside influences such as sunlight, drafts or cold walls.
 - f. Check the locations of all sensors to determine whether their position will allow them to sense only the intended temperatures, humidities, or pressures. Control Contractor will relocate as deemed necessary by the TAB Agency.
 - g. Check the sequence of operation for any control mode is in accordance with approved shop drawings. Verify that only minimum simultaneous heating and cooling occurs. Observe that heating cannot take place until the cooling zone of valve is completely closed.
 - h. Verify that all controller set points meet the design intent.
 - i. Verify the operation of all interlock systems.
 - j. Verify that controllers are calibrated and function as intended.
 - k. Verify that controller setpoints are as specified.
 - l. Verify the operation of lockout or interlock systems.
 - m. Verify the operation of all valve and damper actuators.
 - n. Verify that all controlled devices are properly installed and connected to the correct controller.
 - o. Verify that all controlled devices travel freely and are in the position indicated by the controller: open, closed, or modulating.
 - p. Perform all system verification to assure the safety of the system and its components.
2. Reporting
 - a. The report shall include a summary of verifications performed, remaining deficiencies, and any variations from specified conditions.
3. A systematic check of the above requirements shall be included in the final TAB report.

3.10 FINAL ACCEPTANCE

- A. At the time of final inspection, the T&B Agency shall recheck, in the presence of the Owner's Representative, specific and random selections of data, i.e. water and air quantities, recorded in the Certified Report.
- B. Points and areas for recheck shall be selected by the Owner's Representative.
- C. Measurement and test procedures shall be the same as approved for work forming basis of Certified Report.
- D. Selections for recheck, specific plus random, will not normally exceed 25% of the total number tabulated in the report, except that special air systems may require a complete recheck for safety reasons.
- E. If random tests elicit a measured flow deviation of 10% or more from that recorded in the Certified Report listings, by 10% or more of the selected recheck stations, the report shall be automatically rejected. In the event the report is rejected, all systems shall be readjusted and

tested, new data recorded, new Certified Report submitted, and new inspection tests made, all at no additional cost to the Owner.

- F. Following final acceptance of the Certified Report by the Owner's Representative the settings of all valves, splitters, dampers, and other adjustment devices shall be permanently marked by the T&B Agency, so that adjustment can be restored if disturbed at any time. Devices shall not be marked until after final acceptance.

END OF SECTION

SECTION 23 0923

ENERGY MANAGEMENT SYSTEM FOR HVAC (EMS)

PART 1 - GENERAL

1.01 SUMMARY

- A. Section includes equipment and performance criteria for furnishing all labor and materials for the installation and programming for Energy Management System for HVAC Systems utilizing wireless communication with cloud-based servers.

1.02 RELATED SECTIONS

- A. Division 01: General Requirements
- B. Section 23 0000: Heating, Ventilating, and Air-Conditioning (HVAC)

1.03 SUBMITTALS

- A. Shop Drawings and product data in accordance with the specifications.
- B. All shop drawings shall be prepared in AutoCAD 2012 or newer. In addition, Contractor shall provide drawings in electronic format with x-ref and layer information to other trades as required.
- C. All submittals shall be bound or in a three-ring binder with a table of contents and related section tabs. Five (5) copies shall be submitted to the Architect for distribution and review prior to ordering or fabrication of the equipment. The Contractor, prior to submitting, shall check all documents for accuracy.
- D. Shop drawings shall include basic floor plans depicting locations of all equipment and wiring installed by others, to be controlled by system and locations of thermostats, gateways and other equipment provided under this section. Drawings shall also show location of electrical power, low voltage wiring and data ports, provided by others, required for proper installation of systems of this section.
- E. Submittal data shall contain manufacturer's data on all hardware and software products required by the specification.

1.04 SCOPE OF WORK

- A. Except as otherwise noted, the control system shall consist of all thermostats, and gateways to fill the intent of the specification and provide for a complete and operable system.
- B. The EMS Contractor shall review and study existing building/site conditions where applicable and all new construction drawings for the project, including HVAC drawings, and the entire project specifications to familiarize themselves with the equipment and system operation prior to bidding and submittal of a bid/price. The Contractor shall notify the Owner immediately of any conflicts between the project and the scope of work of this Section, including work to be completed by others.
- C. All equipment and installation of control devices associated with the equipment listed below shall be provided under this Contractor.
- D. When the EMS system is fully installed and operational, the EMS Contractor shall make themselves available to meet with the designated representatives of the Owner to review the as-installed condition of the system. At that time, the EMS Contractor shall demonstrate the

- operation of the system and prove that it complies with the intent of the Drawings and Specifications.
- E. The Contractor shall furnish and install a complete EMS control system including all necessary hardware and all operating and applications software necessary to perform the control sequences of operation. Provide and install EMS controls for the HVAC equipment as noted on the Drawings:
 - 1. Provide technical support necessary for commissioning of system in coordination with the HVAC Contractor, Balancing Contractor and the owner's team.
 - 2. Contractor shall provide one training session in the operation of the system, for owner's personnel.
 - F. EMS Contractor shall provide economizer controller for the Daikin AEQ unit ventilators along with the thermostat. Provide thermostats and tie into Daikin AHF unit ventilators via a terminal strip.
 - G. EMS Contractor shall provide all wiring between sensors and wireless thermostats.
 - H. All work performed under this Section of the Specifications shall be in compliance with all codes and regulations as mandated by the authority having jurisdiction.

1.05 SYSTEM DESCRIPTION

- A. The Energy Management System (EMS) shall consist of thermostats, gateways and related accessories as indicated below and all related programming for a complete and fully operational web based management system, using a cloud server program complying with the following specifications.
- B. The entire Energy Management Solution (EMS) shall include a network of commercial Internet programmable thermostats which use IEEE 802.15.4 mesh wireless communication protocol to reach a Wireless Gateway (WG). The WG must connect to the owner's wide area network (WAN) over a TCP/IP connection. Access and control of EMS is through a web-based management tool which sits on a cloud server and must be accessible either locally or remotely via the Internet.

1.06 WORK BY OTHERS

- A. The EMS Contractor shall coordinate with other Contractors prior to performing the work on this project and cooperate as necessary to achieve a complete and neat installation. To that end, each Contractor shall consult the Drawings and Specifications for all trades to determine the nature and extent of others' work prior to fabrication and installation. The Owner's representative shall be immediately notified if an area of conflict occurs between trades prior to fabrication and installation. EMS Contractor shall provide field supervision to the Mechanical Contractor for pre-installation of control components.
- B. Low voltage thermostat wiring between equipment and thermostat locations shall be furnished and installed by others. Unless noted otherwise all new low voltage wiring shall be multiple conductor thermostat wiring (wire count as indicated in thermostat manufacturer's installation instructions) installed per Owner's specifications. (Wiring in existing installations shall be minimum 3 conductor / 24 gauge wires per EMS manufacturer's standard specifications, multiple c conductor / 24-gauge thermostat wiring preferred - see Installation Instructions for specific conductor counts depending on heating and cooling modes of existing equipment.)
- C. Related work provided by others:
 - 1. 110 V outlets shall be provided within 5 feet of each gateway location.
 - 2. 1 Data port shall be provided within 10 feet of each gateway location.

- D. Equipment start-up and servicing

1.07 CODE COMPLIANCE

- A. Provide EMS components and ancillary equipment which are code compliant.
- B. All wiring shall conform to the National Electrical Code.
- C. All products of the EMS shall reside with the following agency approvals.
 - 1. California 2016 Title 24 Compliant.
 - 2. California Energy Commission Occupant Control Smart Thermostat (OCST) certified.
 - 3. Open ADR2.0 certified.

1.08 SYSTEM STARTUP & COMMISSIONING

- A. Each EMS component in the system shall be tested for both hardware and software functionality. In addition, each mechanical and electrical system under control of the EMS shall be tested against the appropriate sequence of operation specified herein. Successful completion of the system test shall constitute the beginning of the warranty period. A written report shall be submitted to the Owner indicating that the installed system functions in accordance with the Drawings and Specifications.
- B. The EMS Contractor shall provide all manpower and engineering services required to assist the HVAC Contractor and Balancing Contractor in testing, adjusting, and balancing all systems in the building. The EMS Contractor shall have a trained technician available on request during the balancing of the systems. The EMS Contractor shall coordinate all requirements to provide a complete air balance with the Balancing Contractor and shall include all labor and materials in his contract to assist with functional testing of system as it relates to EMS.

1.09 TRAINING

- A. The EMS Contractor shall provide training for two owner's representatives and/or maintenance personnel. The EMS Contractor shall provide on-site training to the District's representative(s) and maintenance personnel per the following description:
 - 1. On-site training shall consist of a minimum of one hour of hands-on instruction geared at the operation and maintenance of the systems. The curriculum shall include
 - a. System Overview
 - b. System Software and Operation
 - c. System access
 - d. Software features overview
 - e. Changing set points and other attributes
 - f. Scheduling
 - g. Editing programmed variables
 - h. Displaying color graphics
 - i. Running reports
 - j. Workstation maintenance
 - k. Application programming
 - l. Operational sequences including start-up, shutdown, adjusting and balancing.
 - m. Equipment maintenance

1.10 OPERATING AND MAINTENANCE MANUALS

- A. The operation and maintenance manuals shall contain all information necessary for the operation, maintenance, replacement, installation, and parts procurement for the entire EMS. This documentation shall include specific part numbers.

- B. Following project completion and testing, the EMS Contractor shall submit as-built documentation reflecting the exact installation of the system.

1.11 WARRANTY

- A. The EMS contractor shall warrant the system for 12 months after system acceptance and beneficial use by the District. During the warranty period, the EMS contractor shall be responsible for all necessary revisions to the software as required to provide a complete and workable system consistent with the letter and intent of the Sequence of Operation section of the specification. EMS equipment shall be warranted for a period of 5 years from the time of system acceptance.
- B. Warranty of equipment is limited to replacement of defective products.

PART 2 - PRODUCTS

2.01 ACCEPTABLE MANUFACTURERS

- A. Unless noted otherwise, all products shall be of a single manufacturer. The standard of design and quality shall be products as manufactured by Pelican Wireless Systems.
- B. Products of other manufacturers shall be considered for acceptance provided they equal or exceed the material requirements and functional requirements of the specified product. A request for Architect's approval must be submitted with complete technical data to allow for proper evaluation. All materials for evaluation must be received by Project Manager at least 10 days prior to bid due date.

2.02 WIRELESS GATEWAY (WG)

- A. A single WG shall be capable of providing communication between a dedicated cloud server using TCP/IP and the on-site Internet Programmable Thermostats using the IEEE 802.15.4 wireless communication protocol. Additional WGs can be used for a single site, but each WG must meet or exceed these requirements.
- B. The WG must provide the following hardware features as a minimum:
 - 1. Single Ethernet Port.
 - 2. One micro-USB 5VDC power input.
 - 3. 2.4 GHz IEEE std. 802.15.4 built-in communication processor.
- C. The WG shall provide the communication link between the entire system and a cloud-based server. Communication with cloud server shall be secured using AES (Advanced Encryption Standard).
- D. The WG shall be able to support 2000 Internet Programmable Thermostats.

2.03 INTERNET PROGRAMMABLE THERMOSTAT (IPT)

- A. Internet Programmable Thermostat shall be a wireless communicating commercial programmable thermostat that uses IEEE 802.15.4 for networking communication and a wiring terminal block for controlling a single zone HVAC unit.
- B. The IPT shall provide a keypad for setting:
 - 1. Temperature Set points.
 - 2. System Mode (Heat, Cool, Auto, Off).
 - 3. Fan Mode (Auto, On).
 - 4. Light Button.

- C. The IPT shall include a wiring terminal for controlling a single zone HVAC unit. The wiring terminal must be able to be removed from the IPT for installations where only 3-wires exist or are available between where the IPT shall be placed and its connection with the HVAC unit it shall be controlling. Over these 3-wires the thermostat must still be able to control the HVAC unit based on these specifications.
- D. The IPT must be configurable using a Web Based App. No thermostat configuration, other than setting the IPT to Conventional, Heat Pump - O, or Heat Pump -B, shall be done at the thermostat. Web based Configuration Setting options shall include:
 - 1. Naming the thermostat
 - 2. Grouping multiple thermostats.
 - 3. Heat Pump or Conventional system setting.
 - 4. If Heat Pump; reversing valve O or B setting.
 - 5. Cycles Per Hour (1 - 6).
 - 6. Anticipation Degrees (0°F - 0.5°F)
 - 7. Calibration Degrees (2.0°F - -2.0°F)
 - 8. Heat Stages (0 - 2)
 - 9. If Heat Pump; Aux Heat (Disabled and/or Enabled Option)
 - 10. Cool Stages (0 - 2)
 - 11. Fan Stages (1 - 2)
 - 12. Fan Circulation Minutes Per Hour.
 - 13. Temperature Display (Fahrenheit or Celsius)
 - 14. Heat Range Temperature Setting Limitation
 - 15. Cool Range Temperature Setting Limitation
 - 16. Ability to disable and enable Keypad Control through schedule.
 - 17. Heat consumption (kw, btu, ton, or watt)
 - 18. Cool consumption (kw, btu, ton, or watt)
 - 19. Notification Sensitivity (High, Medium, Low)
 - 20. Alarm of exceeding temperature based on a Safe Range
 - 21. Schedule set times (2, 3, 4, or Variable).
- E. IPT settings and control through the Web Base App shall be in real-time and include:
 - 1. Space Temperature
 - 2. System Mode (Heat, Cool, Auto, Off).
 - 3. Fan Mode (Auto, On).
 - 4. Current set point.
 - 5. Relay status (Heat/Cool and Fan).
 - 6. Historical Trend Graphs.
 - 7. Scheduling
 - 8. Lock and Unlock Entire Thermostat's Keypad
 - 9. Lock and Unlock the Thermostat's Fan Mode setting Only

2.04 WEB BASED GRAPHICAL USER INTERFACE

- A. The Web Based App (WBA) shall be able to run on any PC that uses Safari, Chrome, Firefox, or any other web browser that meets these browsers' functionality.
- B. The WBA Platform shall be able to run on any Internet Accessible Smartphone and/or Tablet that has a Web Browser compatible with HTML5.
- C. The WBA shall allow up to a minimum of 100 simultaneous users/clients to access the Energy Management System.
- D. The Web Based client shall support at a minimum, the following functions:
 - 1. User log-on identification and password shall be required.

2. HTML programming shall not be required to display any graphics or data on the Web page.
 3. Storage of data shall reside within the cloud server and shall not sit within the client's computer or device. EMS that requires data storage on a client computer or an on-site server is not acceptable.
 4. Users shall have administrator and user definable access privileges.
 5. Open API interface with XML data output.
- E. Schedules:
1. The WBA shall provide user with access to setting Internet Programmable Thermostat (IPT) schedules. Up to 12 schedule periods per day shall be available for each IPT.
 2. Schedules shall be available as Weekly (7-day), Daily, or Weekday/Weekend (5-2).
 3. The WBA shall provide the user the ability to:
 - a. View Schedules.
 - b. Add/Modify Schedules.
 - c. Assign Thermostat to a Group Schedule.
 - d. Delete Schedules.
- F. Trending
1. The WBA shall provide real-time trend information on:
 - a. Each IPT's space temperature.
 - b. Each IPT's temperature set points.
 - c. Each IPT's current call; heat, cool, and/or fan.
 - d. Each IEE's call for economization
 2. The WBA shall be able to record and provide at least two years of past trend data for every thermostat in the wireless network. Trend data shall include:
 - a. space temperature; with resolution of every 1/10th of a degree Fahrenheit.
 - b. IPT's temperature set points.
 - c. indication of whether the thermostat was calling for; heat, cool, and/or fan.
 3. Trend data shall be viewable on the WBS
- G. Alarm Notifications
1. The WBA shall provide automatic alarming functionally based on real-time monitoring of at least:
 - a. space temperature and temperature change.
 - b. IPT's temperature set points.
 - c. IPT's current call; heat, cool, and/or fan.
 2. The WBA shall be able to provide a user with the ability to:
 - a. View Alarms.
 - b. Set Alarm Notification sensitivity level to High, Medium, or Low.
 - c. Delete Alarms.
 3. Alarms shall be able to be sent via email and/or text message to up to 100 or more clients.
- H. Consumption Usage
1. The WBA shall be able to calculate and graphically display the consumption of running a single zone HVAC unit based on a user defined HVAC unit heat and/or cool consumption rate multiplied by the thermostat heat/cool call time.
 2. The WBA shall be able to calculate and graphically display the cost of consumption of running a single zone HVAC unit based on taking a user defined HVAC unit heat and/or cool consumption and multiplying that by the client defined cost per kw and/or therm.
 3. The WBA shall be able to display consumption usage for a single thermostat, multiple thermostats at a single time, or all the thermostats in the EMS.
 4. The WBA shall be able to record and display up to at least two years of consumption usage information.

2.05 WIRED REMOTE TEMPERATURE SENSORS AND DIGITAL ALARM INPUT

- A. Input Temperature Sensor (ITS).
 - 1. The ITS shall connect to the Internet Programmable Thermostat over 3-wires.
 - 2. ITS shall provide at least one external 10K Type II thermistor temperature sensor input.
 - 3. Web Based App shall be able to record and provide at least two years of past temperature data for ITS.
 - 4. The trend data shall be viewable on the WBA.
 - 5. ITS must be accurate to $\pm 1.0^{\circ}\text{F}$
 - 6. ITS must be able to be installed up to 500' away from IPT using standard thermostat wiring.

2.06 INTERNET ENABLED ECONOMIZER (IEE)

- A. The IEE shall connect to the Internet Programmable Thermostat (ITS) with ONLY 3-wires. No additional wiring must be required between the IEE and the ITS to gain complete Title 24 compliant economization control.
- B. IEE shall provide up to three 10K Type II external thermistor temperature sensor input.
- C. Web Based App shall be able to record and provide at least two years of past data for IEE. Data must represent historical representations of:
 - 1. Calls for Economization
 - 2. Outside Air Damper Position
 - 3. Supply and Outside Air Temperature
 - 4. The trend data shall be viewable on the WBA.
 - 5. IEE must be able to send California Title 24 Fault and Diagnostics codes to the WBA, email addresses, and or text messages.
 - 6. IEE must be able to be installed up to 500' away from IPT using standard thermostat wiring.
 - 7. IEE must have a settable 0-10VDC output for Outside Air Damper Actuator control.
 - 8. IEE must have a settable 0-10VDC output for Variable Frequency Drive (VFD) control.
 - 9. IEE must be configurable for different VFD speeds based on calls for cold, heat, and ventilation.
 - 10. IEE must have a 0-10VDC input for Outside Air Damper Position Feedback.

2.07 WIRELESS PROXIMITY SENSORS

- A. Wireless Proximity Sensor (WPS).
 - 1. The WPS shall connect with the Internet Programmable Thermostat over the 802.15.4 wireless network.
 - 2. WPS shall be powered by 2 AA batteries or equivalent.
 - 3. WPS must be able to be used for either:
 - a. Accepting a motion sensor's 2-wire dry contact output.
 - 1) The WPS shall be able to notify an Internet Programmable Thermostat if a motion sensor's dry contact is in either the open or closed position.
 - 2) Dry contact open positions shall indicate that the space is occupied and the IPT must be able to automatically setback its temperature setting by a range of 0°F - 10°F or OFF.
 - 3) Dry contact closed position shall indicate that the space is unoccupied and set the temperature to a comfort setting when the space is occupied.
 - 4) Setback settings and comfort settings must be settable through the Internet Programmable Thermostat's schedule through the Web Based App (cannot be settable at thermostat).

- 5) Web Based App must be able to display when a space is "Unoccupied".
- b. Detecting if a Window or Door is Opened or Closed.
 - 1) The WPS must have a built-in magnetic sensor and come with a magnet that can be installed on a door or window.
 - 2) The WPS must be able to notify an Internet Programmable Thermostat if the door is open and the IPT must automatically turn to the OFF position.
 - 3) The WPS must be able to notify an Internet Programmable Thermostat if the door is closed and the IPT must automatically return to its last temperature and system settings.
 - 4) Web Based App must be able to display when the Door or Window is Open and must be able to be set to indicate "Door" or "Window".
- c. Web Based App shall be able to notify if the WPS batteries are low and record and provide at least two years of past history on occupancy and/or door/window status for each space a WPS is installed in.
- d. The trend data shall be viewable on the Web Based App.
- e. Internet Programmable Thermostat must be able to connect with at least 8 WPS, each WPS must have a unique serial number and each WPS shall be settable, through the Web Based App, as either a motion sensor input or as a door/window sensor.

PART 3 - EXECUTION

3.01 CONTRACTOR RESPONSIBILITIES

- A. General
 1. Installation of the Energy Management System shall be performed by an approved Contractor. The Contractor shall certify all work as proper and complete. Under no circumstances shall the design, scheduling, coordination, programming, training, and warranty requirements for the project be delegated to a subcontractor without prior written approval of the owner.
- B. Demolition
 1. Remove controls which do not remain as part of the Energy Management System. The Owner shall inform the Contractor of any equipment which is to be removed that shall remain the property of the Owner. All other equipment which is removed shall be disposed of by the Contractor.
- C. Access to Site
 1. Unless notified otherwise, entrance to building is restricted. No one shall be permitted to enter the building unless their names have been cleared with the District or the District's Representative.
- D. Code Compliance
 1. All wiring shall be installed in accordance with all applicable electrical codes and shall comply with equipment manufacturer's recommendations.
- E. Cleanup
 1. At the completion of the work, all equipment pertinent to this Section shall be checked and thoroughly cleaned, and all other areas shall be cleaned around equipment provided under this Section.

3.02 WIRING, CONDUIT, AND CABLE

- A. All control wires between HVAC units and thermostat locations to be furnished and installed by others. The EMS contractor shall not begin work on this contract until all wiring is installed to

the satisfaction of the EMS contractor. The EMS contractor shall provide wiring between remote temperature sensors, TA1 and thermostats as required, unless noted otherwise in Drawings or Specifications.

3.03 HARDWARE INSTALLATION

- A. Installation Practices for Devices
 - 1. All devices are to be mounted level/plumb and per the manufacturer's installation documentation.
- B. Identification
 - 1. Identify all control wires with labeling tape or sleeves using either words, letters, or numbers that can be exactly cross-referenced with as-built drawings.
 - 2. All field enclosures, other than controllers, shall be identified with a back lite nameplate. The lettering shall be in white against a black or blue background.
 - 3. Junction box covers shall be marked to indicate that they are a part of the EMS system.
 - 4. All I/O field devices (except space sensors) that are not mounted within FIP's shall be identified with name plates.
 - 5. All I/O field devices inside FIP's shall be labeled.
- C. Existing Controls.
 - 1. Existing controls are not to be reused. All EMS devices shall be new.
- D. Control System Switch-over
 - 1. The Contractor shall minimize control system downtime during switch-over. Sufficient installation mechanics shall be on site so that the entire switch-over can be accomplished in a reasonable time frame.
- E. Location
 - 1. The location of sensors is per mechanical and architectural drawings.
 - 2. Space humidity or temperature sensors shall be mounted away from machinery generating heat, direct light and diffuser air streams.
 - 3. If Input Temperature Sensor(s) (ITS) is used as Outdoor air sensor, Outdoor air sensors shall be mounted on the north building face directly in the outside air. Install sensors such that the effects of heat radiated from the building or sunlight is minimized.
 - 4. If any line voltage electrical control is being installed, field enclosures shall be located immediately adjacent to the controller panel(s) to which it is being interfaced.

3.04 SYSTEM PROGRAMMING

- A. General.
 - 1. The Contractor shall provide all labor necessary to install, initialize, start-up and debug all system software as described in this section. This includes any operating system software.
 - 2. Contractor shall work with owner's representative to determine programming parameters including but not limited to hours of operation, set points, system variables, thermostat naming, and site naming. Thermostat & Site naming shall be performed by the contractor. Naming convention (equipment # or name, or space served) shall be provided by or agreed upon with the Owner.

3.05 COMMISSIONING AND SYSTEM STARTUP

- A. EMS device functional testing.
 - 1. Each system for which a EMS device has been installed shall be tested for proper installation and functional operation. Test shall include on-site control test to verify each

wireless device is responding to signals sent from cloud-based servers and responding in accordance with manufacture's specifications.

END OF SECTION

SECTION 26 0500
BASIC ELECTRICAL REQUIREMENTS

PART 1 - GENERAL

1.01 WORK INCLUDED

- A. Work included in this Section: All materials, labor, equipment, services, and incidentals necessary to install the Electrical Work as shown on the drawings and as specified hereinafter, including, but not limited to the following:
1. Electrical service replacement as outlined on the drawings, including temporary power for construction and PG&E coordination.
 2. New Panelboards and feeders.
 3. Branch circuit wiring, wiring devices and connections to all equipment requiring electrical service.
 4. Connections to Musco provided Sports Lighting System, including 3-phase and 1-phase branch circuits to each of (4) poles.
 5. Lighting fixtures and connections.
 6. Emergency lighting Inverter.
 7. Telecommunications system boxes and conduits (for wiring systems by District).
 8. Fire Alarm system.
 9. Lighting controls and programming.
 10. All required incidental work, such as trenching, electrical testing, and temporary power.
 11. Any other electrical work as might reasonably be implied as required, even though not specifically mentioned herein or shown on the drawings.
 12. It is the intent of the drawings and specifications that systems be complete and, except as otherwise noted, be ready for operation.

1.02 RELATED WORK

- A. Division 1 - General Requirements

1.03 INCORPORATED DOCUMENTS

- A. Requirements of the Division 1 Sections apply to all work in this Section, unless modified herein.
- B. Published specifications, standard tests or recommended methods of trade, industry or government organizations apply to work of this Section where cited by abbreviations noted below, unless modified herein.
1. 2016 California Code of Regulations.
 2. 2016 California Building Standards Administrative Code, Part 1, Title 24, C.C.R.
 3. 2016 California Building Code (CBC), Part 2, Title 24, C.C.R. (Based on 2015 International Building Code with 2016 California Amendments).
 4. 2016 California Electrical Code (CEC), Part 3, Title 24, C.C.R. (Based on 2014 National Electrical Code with 2016 California Amendments).
 5. 2016 California Mechanical Code (CMC), Part 4, Title 24, C.C.R. (Based on 2015 Uniform Mechanical Code with 2016 California Amendments).
 6. 2016 California Plumbing Code (CPC), Part 5, Title 24, C.C.R. (Based on 2015 Uniform Plumbing Code with 2016 California Amendments).
 7. California Energy Code, Part 6, Title 24, C.C.R.
 8. 2016 California Fire Code (CFC), Part 9, Title 24, C.C.R. (Based on 2015 International Fire Code with 2016 California Amendments).
 9. 2016 California Green Building Standards (CALGreen) Code, Part 11.
 10. Underwriters' Laboratories, Inc. (UL).
 11. Local Utility Company regulations.

C. All State and Municipal Codes and Ordinances.

1.04 CONDITIONS AT SITE:

- A. Visit to site is required of all bidders prior to submission of bid. All will be held to have familiarized themselves with all discernible conditions and no extra payment will be allowed for work required because of these conditions, whether specifically mentioned or not.
- B. Lines of other services that are damaged as a result of this work shall promptly be repaired at no expense to the Owner to the complete satisfaction of the Owner.

1.05 QUALITY ASSURANCE

- A. Conformance:
 - 1. All work shall conform to the applicable requirements of Article 1.03 above.
 - 2. The Contractor shall notify the Architect, prior to submission of bid, about any part of the design, which fails to comply with abovementioned requirements.
 - 3. If after contract is awarded, minor changes and additions are required by aforementioned authorities, even though such work is not shown on drawings or covered in the specifications, they shall be included at Contractor's expense.
- B. Coordination:
 - 1. The Contractor shall become familiar with the conditions at the job site, and with the drawings and specifications and plan the installation of the electrical work to conform with the existing conditions and that shown and specified so as to provide the best possible assembly of the combined work of all trades.
 - 2. The Contractor shall work out in advance all "tight" conditions, involving all trades and if found necessary, supplementary drawings shall be prepared by this Contractor, for the Architect's approval, before work proceeds in these areas. No additional costs will be considered for work, which must be relocated due to conflicts with the work of other trades.
 - 3. The Contractor shall coordinate and verify all backbox, device, lighting fixture, or equipment mounting requirements with the devices or equipment to be installed, prior to rough in.

1.06 SUBMITTALS

- A. Product Data:
 - 1. Comply with the provisions of Section 01 33 00 - Submittals.
 - 2. Within 15 days after award of the Contract, submit:
 - a. Complete electrical, lighting, and signal systems material list of all items proposed to be furnished and installed under this Division. Provide manufacturers data sheets for all devices, raceways, fixtures, equipment, and related products to be used for the Division 26.
 - b. Manufacturers' specifications and other data required demonstrating compliance with the specified requirements.
 - c. Manufacturers' recommended installation procedures which, when approved by the Architect, shall become the basis for inspecting and accepting or rejecting actual installation procedures used on the work.
 - 3. Shop Drawings: Furnish shop drawings and/or equipment cuts for the following:
 - a. Light fixtures including drivers and controls.
 - b. Panel boards. Panel board submittals shall include diagrams of the circuit breaker arrangements in the panels. Arrange circuit breakers in panels exactly as shown on the panel schedules in the construction documents.
 - c. EM power inverter.
 - d. Disconnect switches

- e. Lighting controls
- 4. Test Reports:
 - a. Factory Tests: As specified for specific equipment.
 - b. Field Tests: Performance tests as specified for specific equipment.
 - c. Megger Tests: As specified under TESTING.
 - d. When series rated circuit breakers are used, provide a letter from the manufacturer of the equipment confirming that U.L. series rating exists for all protective devices. State the available fault current from the Utility Company and indicate that the overcurrent devices exceed the available fault current at the respective point of protection.
- 5. Maintenance and Operating Manuals:
 - a. Systems Description: Description of operating procedures.
 - b. Controls: Diagrams and description of operation of each system.
 - c. Equipment: Manufacturer's brochures, ratings, certified shop drawings, maintenance data, and parts lists with part numbers. Mark each sheet with equipment identification number and actual installed condition.
 - d. Materials and Accessories: Manufacturer's brochures, parts lists with part numbers, and maintenance data where applicable. Mark each sheet with identification number of system and location of installation.
 - e. The Maintenance and Operation Manual shall be presented in a three ring binder that has tabbed sections as stated below. Provide all information in each section as stated below.
 - 1) 26 2400:
 - (a) Insert the approved submittals for the service gear and panelboards.
 - (b) Provide the names, addresses and telephone numbers of the manufacturer and the two closest manufacturer's representatives of the equipment.
 - 2) 26 5101:
 - (a) Insert the approved submittals for the light fixtures.
 - (b) Highlight the lamp type that was installed for each light fixture.
 - (c) Provide the names, address and telephone numbers of the manufacturer and the closest manufacturer's representative for each light fixture.
 - 3) 26 5101:
 - (a) Insert the approved submittals for the motion sensing light control equipment.
 - (b) Insert all operating instructions.
 - (c) Provide the names, address and telephone number of the manufacturer and the closest manufacturer's representative of the equipment.
 - (d) Include the manufacturer's recommended maintenance of the equipment.
 - 4) 26 5700:
 - (a) Insert the approved submittals for the low voltage lighting control equipment.
 - (b) Insert all operating instructions.
 - (c) Provide the names, address and telephone number of the manufacturer and the closest manufacturer's representative of the equipment.
 - (d) Include the manufacturer's recommended maintenance of the equipment.
 - 5) 28 3101:
 - (a) Complete the "Record Of Completion" entirely.
 - (b) In the "Download File" indicate the exact equipment that the Monitor Modules are monitoring. i.e. fire sprinkler flow switches, tamper switches, etc..

- (c) Simplify the Download File so that it coincides with the submitted and approved fire alarm single line diagram.
 - (d) Provide the names, address and telephone number of the manufacturer and the closest manufacturer's representative of the equipment.
 - (e) Include the manufacturer's recommended maintenance of the equipment.
 - (f) Insert an abbreviated data sheet that states how to test, reset and silence the fire alarm system.
 - (g) Insert the name and telephone number of the Central Station that receives the alarms, and the proper sequence to follow during an alarm.
- 6) 26 0800:
- (a) Insert all feeder and data system testing results.
6. Record Documents: "As-builts": As specified under Paragraph 3.2 of this Section.

1.07 DELIVERY, STORAGE AND HANDLING

- A. Protection: Use all means necessary to protect the materials of this Section before, during, and after installation and to protect the work and materials of all trades.
- B. Delivery and Storage: Deliver all materials to the job site in their original containers with all labels intact and legible at time of use. Store in strict accordance with approved manufacturers' recommendations.
- C. Replacements: In the event of damage, immediately make all repairs and replacements necessary to the approval of the Architect and at no additional cost to the Owner.
- D. This Contractor shall personally, or through an authorized representative, check all materials upon receipt at jobsite for conformance with approved shop drawings and/or plans and specifications.

1.08 SCHEDULING/SEQUENCING

- A. Place orders for all equipment in time to prevent any delay in construction schedule or completion of project. If any materials or equipment are not ordered in time, additional charges made by equipment manufacturers to complete their equipment in time to meet the construction schedule, together with any special handling charges, shall be borne by this Contractor.
- B. The Contractor shall coordinate production and delivery schedule for all Owner-supplied equipment with the equipment suppliers to ensure that all Owner-supplied equipment is delivered to site in coordination with the construction schedule and in such a manner as to cause no delays in completion of the Contract as scheduled.

1.09 REQUIREMENTS

- A. The contract drawings indicate the extent and general arrangements of the conduit wiring systems, etc. If any departures from the contract drawings are deemed necessary by the Contractor, details of such departures and the reasons therefore shall be submitted as soon as practicable, and within thirty-five (35) days after award of the electrical contract.
- B. Unless material list and data is received as a complete and all inclusive submittal within the stipulated time all items shall be provided as specified, with no deviations permitted.
- C. Any and all additional costs incurred by the substitution of electrical material or equipment, or installation thereof, whether architectural, structural, plumbing, mechanical or electrical, shall be borne by the Contractor under this Section.
- D. Burden of proof of equality of any substitution for a specified product is the responsibility of this Contractor.

- E. Where required by Architect to ascertain equality of substitute product, Contractor may be requested to provide the specified item and the submitted substitution for comparison, at no additional cost to the Owner.

1.10 SEISMIC CERTIFICATION AND INSTALLATION OF EQUIPMENT

- A. Provide seismic restraints per applicable code and as specified or indicated. Design restraints to prevent permanent displacement in any direction caused by lateral motion, overturning, or uplift.
- B. Rigidly Supported Equipment, Conduits, and Raceways.
- C. Lighting:
 - 1. Fasten lighting fixtures in suspended ceilings to ceiling grid system or otherwise support from the structures as specified herein and as per details indicated on the Drawings. Comply with National Electric Code (NEC) Article 410.
 - 2. Suspension systems for light fixtures shall allow fixtures to swing a minimum of 45 degrees from the vertical in all directions without contacting obstructions.
 - 3. Free-swinging suspension systems shall have a safety wire or cable attached to the fixture and structure at each support. The wire shall be capable of supporting four times the weight of the lights.
 - 4. Point-source fixtures: provide slack wires to structure at two diagonal corners.
 - 5. Troffer fixtures: provide hold-down clip at each fixture corner, and slack wires to structure at two diagonal corners.
 - 6. Supports for pendants: Provide diagonal seismic wire restraints per Code.
- D. Components supported by chains or simply suspended from above are not required to meet lateral seismic force requirements and seismic relative displacement requirements provided that they cannot be damaged or cannot damage any other component when subject to seismic motion. They must have ductile or articulating connections to the structure at the point of attachment.
- E. Electrical Cabinets:
 - 1. Electrical cabinet design shall conform to National Electrical Manufacturers Association (NEMA) 250 and NEMA ICS6 standards. Cutouts in the lower shear panel that do not appear to have been made by the manufacturer and significantly reduce the strength of the cabinet are not permitted unless analysis demonstrates that the remaining strength is sufficient.
 - 2. Single freestanding cabinets shall have a minimum of four anchor bolts designed and specified with one anchor located at each corner.
 - 3. Multiple sections of cabinets or enclosures located adjacent to each other shall be bolted together. Minimum acceptable bolting is three bolts in the front and back along the adjacent vertical faces - 6 bolts total.
 - 4. Multiple cabinets bolted together to form a section or line-up shall have at a minimum two anchors specified for each cabinet, one at the front and one at the rear.
 - 5. Base anchorage shall be installed through anchor points designated by the Manufacturer. The largest bolt diameter for the anchor hole provided in the equipment shall be provided.
 - 6. A latch or fastener to prevent opening during an earthquake event and damaging the cabinet and internal components shall secure all doors.
 - 7. Slide-out components in electrical control panels, etc., shall have a latching mechanism to hold contents in place.
 - 8. Attached cabling shall have adequate slack or flexibility between the cabinets and surrounding structure supporting the conduit to preclude severing of the cabling due to differential seismic displacements.

- F. The design load shall include the effects of loading on the equipment imposed by attached utility or service lines that are also attached to separate structures.
- G. The attachment of additional external items is not permitted unless such items have either been provided by the Manufacturer, or analysis shows that their effects are supported by design.
- H. Conduit and their connections shall be constructed of ductile materials unless otherwise approved by the Architect. Conduits and their connections constructed of non-ductile materials (e.g., cast iron, no-hub pipe and plastic) shall have brace lengths reduced to one-half that allowed for ductile material.
 - 1. All trapeze assemblies supporting conduit shall be braced to resist CBC design forces considering the total weight of the elements on the trapeze.
 - 2. Seismic restraint spacing shall be in accordance with hanger spacing.

1.11 DESCRIPTION OF WORK

- A. This project involves the renovation of an existing athletic field area, with existing structures, and connections to existing campus systems. As such, the project scope for this contractor will include all associated electrical, lighting, and signal system upgrades and demolition/removal work at the existing site. The intent is that all systems will be complete and functional at the completion of this contract and that all old systems, equipment, feeders, circuits, wiring, and related devices (no longer used) be completely and neatly removed. Where discrepancies between the drawings and existing conditions are noted, the project manager shall be notified immediately for resolution.
- B. As with every renovation project, the electrical work will include (and require) exploration and other field work on a daily basis to complete the new designed equipment and connections within the constraints of the existing building and existing site conditions.
- C. The contractor shall include as part of the base bid, sufficient labor hours to provide such exploration and field work throughout the duration of the project. Change orders for misc. coordination of existing conditions will not be approved unless specific and latent conditions are uncovered that warrant such additional compensation or require additional work not shown on the plans or implied by the designed conditions.
- D. New raceways and wiring to new and renovated equipment are to be installed unless otherwise noted.
- E. All new raceways shall be installed concealed and all new equipment installed flush, unless otherwise noted on the plans or in these specifications.

1.12 GUARANTEE

- A. This Contractor shall guarantee that all work executed under this Section will be free from defects of materials and workmanship for a period of one (1) year or as per the General Conditions of this project, whichever is longer. Dates shall be from the date of final acceptance of the building. The contractor shall further guarantee that he will, at his own expense, repair and replace all such defective work, and all other work damaged thereby, which becomes defective during the term of the guarantee. Such repair or replacement shall be guaranteed for one (1) year from the date of repair or replacement.

1.13 PERMITS AND INSPECTIONS

- A. This Contractor shall arrange for and obtain all required inspections.
- B. Do not allow or cause any of the work to be covered or enclosed until it has been tested and/or inspected.

1.14 IDENTIFICATION

- A. Switchboards, feeder circuit breakers in switchboards, panels, disconnect switches, motor starters, transformers, motor disconnect switches, cabinets, and other apparatus used for the operation of, or control of circuits, appliances or equipment, shall be properly identified by means of engraved laminated plastic descriptive nameplates mounted on apparatus using stainless steel screws. Nameplates shall have white letters with black background and be submitted to the Architect for approval. Cardholders in any form are not acceptable.
- B. Provide p-touch style labeling of circuit designations for all receptacles on the project.
- C. Each branch circuit of panel boards to have a permanently fixed number with load directory, mounted under celluloid on inside of cabinet door, showing circuit numbers and typewritten description of equipment supplied by breakers.

PART 2 - PRODUCTS

2.01 GENERAL

- A. Refer to applicable Division 26, 27, and 28 Sections for complete products specifications.

2.02 MATERIALS

- A. Materials of the same type or classification, used for the same purpose, shall be the product of the same manufacturer.

2.03 ACCEPTABLE MANUFACTURERS

- A. Materials shall be of make mentioned elsewhere in this specification. All materials shall be the best of their several kinds, perfectly new and approved by the Underwriters' Laboratories.
- B. Where material, equipment, apparatus or other products are specified by manufacturer, brand name, type or catalog number, such designation is to establish standards of desired quality, style and utility and shall be the basis of the bid. Materials so specified shall be furnished under the contract unless changed by written approval of the Architect. Where two or more designations are listed, choice shall be optional with this Contractor, but this Contractor must submit his choice for final approval.

2.04 POSTED OPERATING INSTRUCTIONS

- A. Furnish approved operating instructions for systems and equipment where indicated in the technical sections for use by operation and maintenance personnel. The operating instructions shall include wiring diagrams, control diagrams, and control sequence for each principal system and equipment. Print or engrave operating instructions and frame under glass or in approved laminated plastic. Post instructions as directed. Attach or post operating instructions adjacent to each principal system and equipment including startup, proper adjustment, operating, lubrication, shutdown, safety precautions, procedure in the event of equipment failure, and other items of instruction as recommended by the manufacturer of each system or equipment. Provide weather-resistant materials or weatherproof enclosures for operating instruction exposed to the weather. Operating instruction shall not fade when exposed to sunlight and shall be secured to prevent easy removal or peeling.

2.05 CATALOGED PRODUCTS/SERVICE AVAILABILITY

- A. Materials and equipment shall be current products by manufacturers regularly engaged in the production of such products. Products shall have been in satisfactory commercial or industrial use for 2 years prior to bid opening. The 2-year period shall include applications of equipment and materials under similar circumstances and of similar size. The 2-year period shall be satisfactorily completed by a product for sale on the commercial market through advertisements, manufacturers' catalogs, or brochures. Products having less than a 2-year field service record will be acceptable if a certified record of satisfactory field operation for not less

than 6,000 hours, exclusive of the manufacturers' factory or laboratory tests, is furnished. The equipment items shall be supported by service organizations which are reasonable convenient to the equipment installation in order to render satisfactory service to the equipment on a regular and emergency basis during the warranty period of the contract.

PART 3 - EXECUTION

3.01 INSPECTION

- A. Examine the areas and conditions under which the work of this Section will be installed. Correct conditions detrimental to the proper and timely completion of the Work. Do not proceed until unsatisfactory conditions have been corrected.

3.02 PREPARATION

- A. Drawings:
 - 1. The general arrangement and location of wiring and equipment is shown on the electrical drawings and shall be installed in accordance therewith, except for minor changes required by conflict with the work of other trades.
 - 2. The Contractor shall coordinate and verify all backbox, device, or equipment mounting requirements with the devices or equipment to be installed, prior to rough in.
 - 3. Drawings indicate the circuit and panel which supplies each device or fixture. Provide and install conduit and conductors to make all connections from panel to nearest device and from first device to additional devices on same circuit. Conduit size and fill shall satisfy NEC requirements. Two or three different phases supplied by a 3-phase panel may share a single neutral only if circuit positions are adjacent in the panel. Do not exceed 4 #12 or 3 #10 conductors in a 1/2" conduit, 7 #12 or 5 #10 in a 3/4" conduit, and 11 #12 or 9 #10 in a 1" conduit, unless otherwise noted. Provide common handle-tie on breakers for multi-wire branch circuits (with common neutral), per NEC. If more than three current carrying conductors are installed in one conduit, conductor size shall be increased as required per NEC. Do not share neutrals for branch circuit runs to electronic equipment or where noted on the drawings.
 - 4. Drawings indicate the location of all light switches. Where fixtures in a room are controlled by more than one switch, the same lower case letter is drawn adjacent to a switch and each fixture controlled by that switch. Where no lower case letter is adjacent to a switch, all fixtures in the room are controlled by that switch. Provide and install conduit and wire from fixture to switch and between fixtures as required to accomplish switching shown. Do not route branch circuit wiring for light fixtures through switch boxes.
 - 5. Drawings indicate location of all signal outlet boxes. Provide and install conduit system as required and complete system wiring, unless otherwise noted.
 - 6. Control wiring is generally not shown on the plans. Contractor shall refer to control diagrams and provide and install all wiring and raceways required to make all interconnections.
 - 7. All branch circuit wiring No. 12 or No. 10 as noted, all control wiring No. 14, except as noted next to "slash marks" on drawings, or as noted under "Wire," as specified herein.
 - 8. All dimensions, together with locations of doors, partitions, etc. are to be taken from the Architectural Drawings, verified at site by this Contractor.
 - 9. Maintain "as-built" records at all times, showing the exact location of concealed conduits and feeders installed under this contract, and actual numbering of each circuit. Upon completion of work and before acceptance can be considered, this Contractor must forward to Architect vellums (obtained from the Architect at cost) corrected to show the electrical work as installed.
 - 10. Branch circuit conductors shall be #12 minimum and #10 minimum for runs longer than 150 feet.

- B. Measurements: Before ordering any material or closing in any work, verify all measurements on the job. Any differences found between dimensions on the drawings and actual measurements shall be brought to the Architect's attention for consideration before proceeding.

3.03 FIELD QUALITY CONTROL

- A. All workmanship shall be first class and carried out in a manner satisfactory to and approved by the Architect.
- B. This Contractor shall personally, or through an authorized and competent representative, constantly supervise the work and so far as possible keep the same foreman and workmen on the job throughout.

3.04 COORDINATION

- A. In electrical rooms, Contractor is responsible for installation of electrical equipment within the space provided. Contractor shall provide ¼" scale plans of electrical room layouts, and elevations of steel channel supports (where used or required) of electrical equipment for review and approval prior to any installation or rough-in

3.05 INSTALLATION/APPLICATION/ERECTION

- A. All electrical raceways and devices shall be installed concealed (for raceways) and/or flush mounted (for devices), unless otherwise noted.
- B. All cutting, repairing and structural reinforcing for the installation of this work shall be done by the General Contractor in conformance with the Architect's requirements.

3.06 TEMPORARY LIGHTING AND POWER

- A. Provide and install temporary lighting and power systems for the duration of construction, of adequate size to accommodate the required lighting and power loads. Coordinate with other trades to insure adequate sizing.
- B. Provide distribution equipment as required to support all construction activities.

3.07 FIRE STOPPING AND FIRE RATED PENETRATIONS

- A. All electrical equipment mounted in, on, or through fire rated construction shall be installed to maintain the fire rating of the construction.
- B. Provide fire rated pads (or other suitable assembly) around all electrical junction boxes in fire rated walls/ceilings/floors to maintain the fire rating.
- C. Provide fire rated construction around all recessed light fixtures and/or panel board / cabinets mounted flush in fire rated walls to maintain the fire rating. Coordinate depth of construction with other trades to avoid conflicts.
- D. Conduit sleeves shall be provided as a means of routing cables through fire-rated walls or floors. Openings in sleeves and conduits used for system cables and those which remain (empty) spare shall be sealed with an approved fireproof, removable sagging material. Sleeves which pass vertically from floor to floor shall be sealed in a similar manner using an approved re-enterable system. Additional penetrations through rated assemblies necessary for passage of tel/data wiring shall be made using an approved method and permanently sealed after installation of cables.

3.08 ADJUSTING AND CLEANING

- A. All electrical equipment, including existing equipment not "finish painted" under other sections, shall be touched up where finished surface is marred or damaged.
- B. All equipment, lighting fixtures, etc., shall be left in clean condition, with all shipping and otherwise unnecessary labels removed there from.

3.09 SCHEDULES

- A. Coordination: Coordinate installation of electrical items with the schedule for other work to prevent unnecessary delays in the total Work.

3.10 WARNING SIGN MOUNTING

- A. Provide the number of signs required to be readable from each accessible side, but space the signs a maximum of 30 feet apart.

3.11 PAINTING OF EQUIPMENT

- A. Factory Applied: Electrical equipment shall have factory-applied painting systems which shall, as a minimum, meet the requirements of NEMA ICS 6 corrosion-resistance test, except equipment specified to meet requirements of ANSI C37.20 shall have a finish as specified in ANSI C37.20.
- B. Field Applied: Paint electrical equipment as required to match finish or meet safety criteria. Painting shall be as specified in the respective equipment section.

3.12 TESTS

- A. Testing and inspection: See Section 26 08 00 - Testing.

END OF SECTION

SECTION 26 0800

TESTING

PART 1 - GENERAL

1.01 WORK INCLUDED

- A. Work Included in This Section: All materials, labor, equipment, services, and incidentals necessary to perform the testing and inspection of the electrical work, including but not limited to the general systems noted below:
 - 1. Grounding System.
 - 2. Lighting System.
 - 3. Distribution System.
 - 4. Fire Alarm System.
 - 5. Lighting controls
 - 6. Lighting emergency inverter system
- B. Any other electrical work as might reasonably be implied as required, even though not specifically mentioned herein or shown on the drawings.
- C. All work shall comply with Sections 26 05 00 and 26 27 00.
- D. In addition to the general system tests and inspections indicated above, the Contractor shall perform the following specific tests and inspections with certified and calibrated testing equipment:
 - 1. System Grounding
 - 2. Panel boards
 - 3. Feeders
- E. The purpose of these tests is to assure that all tested electrical equipment is operational and within industry and manufacturer's tolerances and is installed in accordance with design specifications.

1.02 APPLICABLE CODES, STANDARDS, AND REFERENCES

- A. All inspections and tests shall be in accordance with the International Electrical Testing Association - Acceptance Testing Specifications ATS-2015 (referred to herein as NETA ATS-2015).

1.03 QUALIFICATIONS

- A. Qualifications of the Contractor shall be as listed in NETA ATS-2015.

PART 2 - PRODUCTS

2.01 THIS ARTICLE DOES NOT APPLY TO TESTING.

PART 3 - EXECUTION

3.01 GENERAL

- A. Final test and inspection to be conducted in presence of the Authority having Jurisdiction (AHJ) or Inspector of Record (IOR). Test shall be conducted at the expense of, and managed by, the Contractor, at a mutually agreed time. Submit written test report of all tests, with test result values and overall outcome.
- B. All portions of the electrical installation shall be inspected and tested to ensure safety to building occupants, operating personnel, conformity to code authorities and Contract Documents, and for proper system operation.

3.02 INSPECTIONS AND TESTS

- A. Tests: Field tests shall be performed and reports submitted, as per Section 26 05 00, Part 1.

1. Final Inspection Certificates: Prior to final payment approval, deliver to the Owner, with a copy to the Architect, signed certificates of final inspection by the appropriate local authority having jurisdiction.
- B. Grounding System:
 1. All ground connections shall be checked and the entire system shall be checked for continuity. The resistance of the ground system shall be measured using a 3 point fall-of-potential method. The maximum ground resistance shall be three ohms. If the measured ground resistance exceeds three ohms, install an additional ground rod.
 2. Ground tests shall meet the requirements of the National Electric Code.
- C. Lighting Systems:
 1. The interior and exterior lighting systems shall be checked for proper local controls and operation of entire installation, including the operation of the low voltage lighting control system.
- D. Power Distribution System:
 1. Test panel boards for grounds and shorts with mains disconnected from feeders, branch circuits connected and circuit breakers closed, all fixtures in place and permanently connected and grounding jumper to neutral lifted and with all wall switches closed.
 2. Test each individual circuit at each panelboard with equipment connected for proper operation. Inspect the interior of each panel.
 3. Check verification of color coding, tagging, numbering, and splice make-up.
 4. Verify that all conductors associated with each circuit are in same conduit.
 5. Demonstrate that all lights, jacks, switches, outlets, and equipment operate satisfactorily and as called for.
 6. Perform megger tests of all new distribution system feeders prior to energizing. All Cables failing megger tests or with evidence of damage shall be removed and replaced in their entirety (no splices), at no cost to the Owner. Damaged cables may not be field repaired without specific approval of the Architect.
- E. Fire Alarm System: Verify that all equipment, components, and devices function as specified. Refer to Section 28 3101 for additional testing requirements.
- F. Lighting Controls: Verify that all equipment, components, and devices function as specified. 265700
- G. Title 24 Acceptance Testing: Contractor shall complete the requirements for Title 24 Acceptance Testing, as per CA Title 24, Part 6.
 1. Perform testing requirements as per Title 24 Lighting Acceptance requirements. Testing shall include construction inspection of installed controls, occupancy sensor testing, manual daylighting controls testing, and automatic time switch controls testing.
 2. Complete and submit required LTG forms for Lighting Control Acceptance and Automatic Daylighting Controls Acceptance.
 3. Obtain required review and approval of Acceptance Forms to allow final certificate of occupancy to be granted.

END OF SECTION

SECTION 26 2400
SERVICE AND DISTRIBUTION SYSTEM

PART 1 - GENERAL

1.01 WORK INCLUDED

- A. Work Included in This Section: All materials, labor, equipment, services and incidentals necessary to install the electrical work as shown on the drawings and as specified hereinafter, including but not limited to the work listed below.
- B. Underground service distribution conduits and boxes for new power service.
- C. Temporary power for construction.
- D. Concrete pad and ground rods for Utility installed padmounted transformer.
- E. Main switchboard, Distribution Panels, Transformers, Distribution System, Panel Boards, Grounding, and Overcurrent Protective Devices.
- F. All required incidental work, such as excavating, backfilling, testing, and temporary power.
- G. Any other electrical work as might reasonably be implied as required, even though not specifically mentioned herein or shown on the drawings.
- H. All work shall comply with Sections 26 05 00 and 26 27 00.

1.02 SUBMITTALS

- A. Comply with the provisions of Section 26 05 00 - Submittals.

PART 2 - PRODUCTS

2.01 ACCEPTABLE MANUFACTURERS

- A. Refer to Section 26 05 00, Part 2 - Products
- B. All new equipment shall match existing.
- C. List of Equipment Manufacturers:
 - Main Switchboard
 - Cutler Hammer, General Electric, Industrial Electric Manufacturing, Electrical Power Products, Square D.
 - Panelboards and Distribution Panel
 - Same manufacturer as main switchboard.
 - Dry-type Transformers
 - Cutler Hammer, International Transformer Corporation, Square D, General Electric.

2.02 MATERIALS

- A. Provide and install conduits for primary cables by utility company, concrete pad and grounding for utility company transformer, and conduit for secondary service to main switchboard. Comply with all Utility Co. requirements.
- B. Furnish and install telecom system conduits and pullboxes.
- C. Grounding:
 - 1. Provide and install grounding systems as noted on the drawings.
 - 2. Grounding electrode conductor: bare stranded copper type, #4/O minimum.
 - 3. Install ground wires in rigid conduit.
 - 4. All grounding electrode conductor connections "thermite" or "cad-weld" welded.
 - 5. Use approved pressure type solderless connector or use fusion welding for all connections to and bonding of grounding electrode system. All connections shall be

- visible, readily accessible for testing purposes. Grounding electrode conductor between the grounding electrode and service equipment: Minimum #4/0.
6. Furnish and install solid copper 5/8" x 10'-0" ground rod(s). Where multiple ground rods are shown, install a minimum of 20'-0" apart. Install ground rods in accessible boxes with covers. Furnish and install 2-#4/0 bare copper cables between multiple ground rods and main switchboard ground bus.
 7. Terminate grounding conduits at equipment with ground bushing, with ground wire connected through bushing.
 8. Provide No. 12 stranded (green) THHN conductor from outlet box to ground screw of every receptacle.
 9. Ground all isolated sections of metallic raceways.
 10. Provide #12 minimum stranded (green) THHN conductor sized per NEC, or as noted, connected continuously throughout branch circuit for all circuits, bonded to panel ground bus, and to all electrical devices and equipment enclosures.
 11. Grounding electrode installed as follows:
 - a. Place #4/0 bare copper cable in foundation trench; tensioned, supported in such a manner that it cannot be less than two (2) inches from bottom or side of concrete when foundation concrete is poured; not less than one hundred feet of conductor. Embed in foundation with a loop at approximate center, brought out at top of foundation adjacent to building service equipment for connection to service equipment and for bonding to other parts of the grounding system.
 - b. Use approved pressure type solderless connector or use fusion welding for all connections to grounding electrode. Connection visible, readily accessible for testing purposes. Grounding electrode conductor between the grounding electrode and service equipment: Minimum #4/0.
 - c. Connect grounding electrode system to metallic water service entry metallic cold water pipe (if available) with nonferrous clamp and bare copper cable (sized as required) in conduit. Connection shall be accessible for inspection.
 - d. Connect grounding electrode system to building steel as noted on Drawings. Use exothermic weld, connection shall be accessible for inspection.
 - e. After installation, test system using the three-point fall of potential method only. Record results and submit to Architect for approval. If resistance to ground exceeds three (3) ohms, install an additional ground rod, bonded and interconnected to grounding electrode system.
- D. Main Switchboard:
1. General: Switchboard shall be distribution panel type, metal enclosure with ground bus and insulated full capacity neutral bus.
 2. Equipment:
 - a. The switchboard shall be Nema 3R rated for exterior installation.
 - b. The switchboard shall be braced for a short circuit current of 65,000 amps. Bracing shall be per NEMA and UL standards.
 - c. The switchboard shall comply with all the requirements of the Utility Company.
 3. The switchboard shall be floor-mounted, self-supporting, dead-front and rear, front-operated, front-connected, distribution type. The enclosure shall be 90 inches high, made of cold rolled steel on a structural shape, or formed, steel frame and shall be mounted on two 3-inch, 5-pound continuous channel iron sills, which shall be closed at the ends between the two channels.
 4. This contractor is responsible for the complete installation of the new switchboard within the space provided (both vertical and horizontal) and shall verify and/or coordinate all

dimensions prior to ordering equipment. Proper allowances should be included to allow complete installation and erection.

5. The switchboard shall be a minimum of 20 inches deep and shall be constructed of National Electrical Code (NEC) gauge steel.
6. The switchboard shall be provided with a cable pull section at the top of the switchboard. Provide a minimum 12 inches of vertical clearance between the cable terminal lugs bolted to the switchboard busses and the top and bottom of the switchboard enclosure. Horizontal pull sections and gutters shall be kept free and clear of busses. Where busses cross vertical pull sections, the busses shall be insulated.
7. All connections between bus bars shall be of a bolted type using Belleville washers. Clamps will not be accepted. All bus bars shall be accurately formed, and all holes shall be made in a manner which will permit bus bars and connections to be fitted into place without being forced.
8. The design of all current-carrying devices or parts of the switchboard shall conform to the standard specified in the related sections of Underwriters' Laboratories, Inc. (UL) No. UL-891 and National Electric Manufacturer's Association (NEMA) Standard PB-2, except as these characteristics may be modified herein.
9. Bus bars, connection bars and wiring on the back of the switchboard shall be arranged so that maximum accessibility is provided for cable connections from the front.
10. Ampere ratings for rectangular bus bars shall be in accordance with the temperature rise standard of National Electric Manufacturer's Association (NEMA) and the Underwriters' Laboratories, Inc. (UL).
11. The enclosure shall be chemically cleaned by parkerizing, bonderizing or phosphorizing as a unit after all welding has been completed. The enclosure shall then be painted with a rust-resisting primer coat of paint and shall be finished with a coat of light gray, baked enamel.
12. Each section shall be bussed for the full connected load of that section. Extend bussing to spare circuit breaker "Spaces." Drill busses for future circuit breakers, and provide breaker connector hardware as required.
13. Provide copper bus bars and connections with silver-plated contact surfaces.
14. The contact surfaces and studs of all devices to which bus connections are made shall also have silver-plated surfaces.
15. Locate ground bus, with a cross-section equal to at least 25 percent of the capacity of the main bus rating, in the back of the switchboard and extend bus throughout the length of the switchboard assembly. Ground each housing of the assembly directly to this bus.
16. Rigidly support all bus and connection bars and current transformers.
17. Fit all nuts and connections with locking devices to prevent loosening.
18. Provide load connections with solderless lugs. Factory-install all devices shown on Drawings as specified herein.
19. Provide a bonding strap from the equipment ground bus to the neutral bus.

E. Panelboards:

1. Surface or flush mounted, with branch circuits as shown on drawings.
2. Enclosures: code gauge galvanized sheet steel with welded full flange end pieces, stretcher- leveled steel trim, backpan and door.
3. Bussing of copper with silver-plated contact surfaces.
4. Trims on surface-mounted cabinets secured with nickel-plated screws with cup washers, bottom of all trims to have lugs for resting on cabinet flange.
5. Panels shall be 20 inches minimum in width, provided with approved gutter space, barriers and adjustable supports. Doors mounted with concealed hinges provided with combination spring latch and lock. Doors and trims and surface mounted cabinets

- primed and finished with one coat baked on gray enamel. All visible panel enclosures and covers in finished (occupied) areas shall be painted to match adjacent wall finish.
6. Breakers on same phase to be aligned horizontally. Each panel provided with 5-handle locks.
 7. Each branch circuit of panelboards to have a permanently fixed number with one word directory, mounted under celluloid on inside of cabinet door, showing circuit numbers and typewritten description of outlets controlled by breakers. Color code mains and each breaker terminal, same as conductor insulation.
 8. Each panel shall be equipped with a copper ground bus.
 9. All panels shall be fully bussed to accept future circuit breakers.
 10. Panel board submittals shall include diagrams of the circuit breaker arrangements in the panels. Arrange circuit breakers in panels exactly as shown on the panel schedules in the construction documents.
- F. Circuit Breakers:
1. General: Circuit breakers shall be molded case rated for 480 or 240 volts, multiple or single pole and amperage rating as shown on the drawings, bolt on, manually operated with "de-ion" arc chutes.
 2. Main circuit breaker shall be rated to interrupt the available short circuit current 65,000 amps RMS.
 3. Distribution circuit breakers shall be rated for the amps interrupting capacity noted on the drawings or U.L. series rated with the main circuit breaker.
 4. Branch circuit breakers shall be rated for the amps interrupting capacity or U.L. series rated with the distribution and main circuit breakers, General Electric type THQB or equal, minimum 10,000 A.I.C for 120/208 volt; type TEY or equal, minimum 14,000 A.I.C for 277/480 volt.
 5. Where mechanical equipment is U.L. listed for overcurrent protection with fuses or HACR type circuit breakers, provide fuses where a fused switch is shown. Where the overcurrent protection is a circuit breaker provide HACR, (HACR means Heating, Air-Conditioning and Refrigeration) type.
- G. Dry-Type Transformers:
1. Ventilated type.
 2. Dry-type general distribution transformers shall meet the California Title 24 requirements for energy efficiency standards and NEMA standard TP-1 for energy efficient transformers.
 3. Transformer shall be 3 phase, 60 Hertz. Primary winding shall be Delta connected and secondary winding shall be Wye connected. The temperature rise at rated voltage and full load shall not exceed 150 degrees C with a 220 degrees C U.L. Component Recognized Insulation System. The windings shall be Aluminum or Copper.
 4. The higher voltage winding shall have quantity (6) 2.5% taps - (2) FCAN and (4) FCBN. Set secondary voltage for 120/208V.
 5. Transformer terminals shall be front connected for ease of installation and maintenance.
 6. Where the transformers are installed outdoors provide weatherproof drip cover, rodent screen and a NEMA 3R rating of the enclosure.
- H. Magnetic starters: shall be rated in accordance with latest published NEMA standards for size and horsepower rating, Westinghouse A-200 series or equal. Provide with overload sensor in each phase, hand-off-auto switch, red "run" pilotlight, in NEMA 1, NEMA 4X, or NEMA 3R enclosure or in motor control center where indicated. Coil shall be rated 120 VAC. Starters shall be across-the-line nonreversing unless otherwise noted.

1. Contacts: Across-the-line magnetic starters shall be equipped with double break silver alloy contacts. All contacts shall be replaceable without removing power wiring or removing starter from panel. The starter must have straight-through wiring.
2. Coils: Coils shall be of molded construction. All coils shall be replaceable from the front without removing the starter from the panel.
3. Overload Relays and Thermal Units: Overload relays shall be the melting alloy type with a replaceable control circuit module. Thermal units shall be of one-piece construction and interchangeable. The starter shall be inoperative if the thermal unit is removed.

2.03 ARC FLASH EVALUATION STUDY

- A. An arc flash evaluation study shall be performed to determine, in coordination with the Owner's safety policy, the required personal protective equipment (PPE) when working on energized equipment.
- B. The arc flash evaluation study shall comply with all NFPA 70E and OSHA requirements for calculating and identifying incident energy levels and the corresponding PPE that would be required in each instance.
- C. The calculated incident energy levels and recommended PPE for each location shall be summarized in a tabulated form listing location, circuit identification, and PPE. Discrepancies, problem areas, or inadequacies shall be promptly brought to the Architect's attention.
- D. Arc flash calculations shall be based on values of fault current magnitudes identified in the short-circuit analysis and the associated clearing times of the over current protective devices determined by the coordination study. The settings recommended by the coordination study shall be the basis of arc flash calculations.
- E. Calculation methods shall comply with IEEE Standard 1584 "IEEE Guide for Performing Arc-Flash Hazard Calculations".
- F. Per IEEE Standard 1584, a maximum arc time of two seconds shall be utilized to limit incident energy values.
- G. Recommended settings of all protective equipment based on the short circuit and equipment coordination study shall be implemented prior to attaching arc flash hazard labels to the equipment.
- H. All electrical equipment shall be field marked to indicate where a flash hazard exists in compliance with NEC 110-116. Labels shall be submitted for approval prior to application. Labels shall be clearly visible to qualified persons before examination, adjustment, servicing, or maintenance of the equipment.

PART 3 - EXECUTION

3.01 REFER TO SECTION 26 05 00 FOR DETAILS OF WORK UNDER THIS SECTION.

3.02 INSTALLATION/APPLICATION/ERECTION

- A. Electric Service Replacement: Contact the local electric utility company service planning representative and coordinate with and arrange with the utility company for new (replacement) electric service to the project, including service application as required. Furnish and install all materials and labor necessary for complete installation as noted on drawings. Submit shop drawings and obtain approval from the utility company prior to fabrication. Also provide and install temporary power as required for construction operations.
- B. Excavate and trench as necessary for the electrical installation, and when the work has been installed, inspected and approved, backfill all excavations with clean earth from excavation, or imported sandy soil in maximum 8" (eight-inch) layers, moisten and machine tamp to 95% compaction, and restore the ground and/or paving or floor surfaces to their original condition.

- C. Switchboard Installation: Provide mounting channels for grouting into floor. Channels shall be properly drilled to receive the switchboard placed flush in floor, leveled and secured in place prior to pouring of floor, of length as required for switchboard. Bolt or weld switchboard to channels.
- D. Motor Connections:
 - 1. Install motor circuits complete for all motors by other trades
 - 2. Furnish and install all disconnect switches, outlet boxes, etc., as required by code.
 - 3. All motor and temperature control low voltage wiring shall be installed and connected by Division 23 Section of specifications, unless otherwise indicated on electrical drawings.

3.03 TESTS

- A. Testing and Inspection: See Section 26 08 00 - Testing.

END OF SECTION

SECTION 26 2700
BASIC ELECTRICAL MATERIALS AND METHODS

PART 1 - GENERAL

1.01 WORK INCLUDED

- A. Work included in this Section: All materials, labor, equipment, services, and incidentals necessary to install the electrical work as shown on the drawings and as specified hereinafter, including but not limited to the work listed below:
 - 1. Raceways, feeders, branch circuit wiring, wiring devices, safety switches and connections to all equipment requiring electric service.
- B. Any other electrical work as might reasonably be implied as required, even though not specifically mentioned herein or shown on the drawings.
- C. All work shall comply with Section 26 0500.

1.02 SUBMITTALS

- A. Comply with the provisions of Section 26 0500.

PART 2 - PRODUCTS

2.01 ACCEPTABLE MANUFACTURERS

- A. Refer to Section 26 05 00, Basic Electrical Requirements, Part 2 - Products.
- B. List of Equipment Manufacturers:
 - Conduit and Conduit Fittings
Allied Tube and Conduit, Wester Tube and Conduit, LTV Steel Tubular, National Electric Products, AFC, Republic Steel Corporation, Rome Cable Corporation, United States Steel Corporation, Killark Electric Manufacturing Company, Raco, VAW Aluminum Company, Bridgeport, Steel City, Thomas & Betts, Carlon, O.Z. Gedney, Appleton, Regal.
 - Wire and Cable (600V)
American Wire Company, General Wire and Cable Corporation, Okonite Company, Rome Cable Corporation, Cerrowire, American Insulated Wire, AFC Cable Systems, Essex, Simplex Wire and Cable Company, Southwire.
 - Solderless Lugs and Grounding Connections
Burndy Engineering Company Inc, O.Z. Gedney Company Inc, Penn Union Electric Corporation, Thomas and Betts Company Inc.
 - Pull Boxes, Gutters, Special Cabinets
Square D Company, Columbia Electric Manufacturing Company, General Electric Company, Westinghouse Electric Corporation, Circle Awalt.
 - Outlet Boxes
Appleton Electric Company, Killark Electric Manufacturing Company, Lew Electric Fittings Company, National Electric Products Corporation, Raco, Steel City Electric Company, Carlon, Bowers.
 - Wiring Devices
Leviton, Arrow-Hart, Cooper, Hubbell, Lutron, Bryant.
 - Conduit Racks, Hangers
General Electric Company, Killark Electric Manufacturing Company, Caddy, National Electric Products Corporation, Republic Steel Corporation, Rome Cable Corporation, United States Steel Corporation, VAW Aluminum Company, Superstrut, B-Line.

Safety Switches (Disconnect and Fusible)

Square D Company, Cutler Hammer Inc, General Electric Company, Westinghouse Electric Corporation.

Fuses

Bussman Manufacturing Company, Chase-Shawmut Company.

Firestopping

3M, Nelson.

2.02 MATERIALS

- A. Raceways: Only the raceways specified below shall be utilized on this project. Substitutions shall be pre-approved in writing. All bare conduit ends (stub-ups or stub-outs) shall be provided with bushed ends or manufactured insulated throat connectors:
1. Rigid Type - hot dip galvanized or sherardized steel, use on all exterior locations, below grade or in concrete slab, and to 18" on either side of structural expansion joints in floor slabs, with completely watertight, threaded fittings throughout. Compression fittings are not acceptable.
 - a. All rigid steel conduit couplings and elbows in soil or concrete or under membrane to be ½ lap wrapped with Scotch #50 tape and threaded ends coated with T&B #S.C.40 rust inhibitor prior to installation of couplings.
 - b. ½ lap wrap all rigid steel conduit stub-ups from slab or grade to 6" above finished grade level with Scotch #50 tape.
 2. In lieu of rigid steel conduit for power and control raceways and branch circuit conduits in soil or concrete slabs, "Schedule 40" PVC with Schedule 80 PVC conduit elbows and stub-ups may be used with code size (minimum No. 12) ground wire. A "stub-up" is considered to terminate 6" above the finished surface.
 - a. Schedule 80 PVC conduit shall be used in all concrete footings or foundations and to 18" of either side of footings or foundation walls.
 - b. Schedule 80 PVC conduit shall be used in all concrete masonry unit (CMU) walls or columns.
 - c. All conduit runs in concrete floor slabs (where allowed) shall be installed to comply with all applicable UBC and structural codes to maintain the structural integrity of the floor slab. Where conflicts occur, alternate routing shall be provided at no additional cost to the Owner.
 - d. Where schedule 80 PVC is coupled to schedule 40 or other raceways with differing interior dimensions, each end shall be reamed with a reaming tool to reduce the edge profile for protection of the passing conductors during the pull.
 3. Electrical metallic tubing shall be used exposed in interior electrical and mechanical rooms, in interior unfinished spaces, and in interior concealed and furred spaces, made up with steel watertight or steel set screw type fittings and couplings. EMT shall not be used in under-building crawl spaces or other areas subject to moisture. Set screws shall have hardened points. Cast fittings are unacceptable.
 4. Use flexible conduit for all motor, transformer and recessed fixture connections, minimum ½"; "Seal tite" type used outdoors and in all wet locations, provide with code size (minimum No. 12) bare ground wire in all flexible conduit.
 5. All conduit cuts (factory or field cut) shall be perfectly square to the length of the conduit and cut ends shall be reamed with a reaming tool to provide a smooth edge to the passing conductors and to remove all burrs and scrapes. Use of a hand file is not acceptable.

6. All electrical raceways shall be installed concealed, unless otherwise noted. Cut and patch to facilitate such installation to match adjacent and original finish. All exposed conduits, where required, shall be installed parallel to building members.
 7. Where existing conditions preclude the installation of EMT in existing walls to remain, provide and install cut-in type boxes and "fish" flexible MC or flex conduit and wire through existing walls to remain, unless shown otherwise on plans.
 8. Fasten conduits securely to boxes with locknuts and bushings to provide good electrical continuity.
 9. Provide chrome escutcheon plates at all exposed wall, ceiling and floor conduit penetrations.
 10. Support individual suspended conduits with heavy malleable strap or rod hangers; supports for 1/2 inch or 3/4 inch conduit placed on maximum 7-foot centers; maximum 10-foot centers on conduits 1 inch or larger.
 11. Support multiple conduit runs from Kindorf B907 channels with C-105 and C-106 straps.
 12. Conduit bends - long radius.
 13. Flash conduits through roof, using approved roof jack; coordinate with General Contractor.
 14. To facilitate pulling of feeder conductors, install junction boxes as shown or required.
 15. All empty conduits on the project shall be provided with a nylon pull rope to allow pulling of future conductors intended for the specific raceway. Provide plastic wire-tie style nameplate tags on each end of pull rope with printed identification of conduit use and the location of the opposite end of the rope. Pull ropes for telephone and cable tv service conduits shall meet the respective utility company requirements.
 16. Minimum cover of conduits in ground outside of building - 24 inches, unless otherwise noted.
- B. Outlet Boxes and Junction Boxes. Verify all backbox requirements with devices to be installed prior to rough-in.
1. One piece steel knockout type drawn boxes, unless otherwise noted, sized as required for conditions at each outlet or as noted.
 2. Flush-mounted boxes equipped with galvanized steel raised covers for device mounting flush with finished surface. Provide extension rings as required on all acoustical or additional wall treatment areas to bring top of cover flush with finished surface (coordinate with architectural drawings). Devices shall be capable of being tightly mounted to boxes without distorting or bending device or mounting hardware.
 3. Boxes for fixture outlets: 4-inch octagon or larger as required, or as noted.
 4. Switch and receptacle outlets - not smaller than 4-inch-square in furred walls, with raised cover for single device; ganged where required.
 5. Outlet and switch boxes for wet locations, cast aluminum FS or FD type with cast aluminum gasketed spring lid cover. Weatherproof "Bell" type boxes are not acceptable.
 6. All connectors from conduit to junction or outlet boxes shall have insulated throats. Connectors shall be manufactured with insulated throats as integral part. Insertable insulated throats are unacceptable.
 7. Outlet boxes for cable TV, telephone, 4" square or larger as required or noted, multi-ganged for telephone, data, and other services where indicated on the drawings.
 8. Conduit Bodies: Malleable iron type, with lubricated spring steel clips over edge of conduit body, O-Z/Gedney type EW, or equal.
 9. Pull boxes: All site pull boxes shall be flush in-ground concrete, with engraved covers identifying service use (i.e. electrical, communications, etc.). Boxes shall be Nema 250, Type 6, outside flanged, with recessed cover for flush mounting, by Christy or equal, with required depth to provide box and conduit depths shown or required.

- a. Provide concrete covers for all boxes in planted or paved areas (up to available concrete cover size).
 - b. Provide galvanized steel covers for all larger boxes (when concrete is not available), or in traffic areas. No cast iron covers.
 - c. Provide bolted covers and slab bottoms (with grouted perimeter) or vault type boxes for all electrical distribution and signal system pull boxes used for site distribution, to prevent rodent entry. No collar type boxes with dirt or gravel bottoms
 - d. Provide drain hole at bottom of all vault type boxes, with loose aggregate base below, for proper drainage.
 - e. All covers to be completely flush with finished adjacent surfaces.
 - f. Provide galvanized steel H20 rated covers and installation of box rated for H20 in all traffic areas.
 - g. Provide pullboxes per utility company specifications for all electrical primary and secondary services and for cable TV and telephone service runs. Verify exact size and type prior to order with each utility company.
- C. Wire and Cable (line voltage and signal systems):
1. 600-volt class where used for or run with line voltage power wiring, insulation color coded, minimum No. 12 awg for power branch circuits, No. 14 for power control circuits, and wiring size and type as directed by signal system manufacturer for each signal system.
 2. All conductors shall be copper.
 3. Size and insulation type:
 - a. Standard locations: #12 to #1 AWG: THWN for wet locations and THHN for dry locations. #1/0 through #4/0 AWG: XHHW (55 Mils). 250MCM and larger: XHHW (65 Mils). All wire sizes used shall be based on a 75 degree insulation rating, unless specifically used with 90 degree rated breakers and devices.
 - b. All wiring (power and signal) installed underground between buildings, or in wet or damp locations, shall be outside listed and rated for wet locations.
 - c. High temperature and non-standard locations: Provide wire type and insulation category suitable for area of use as defined in NEC table 310-13.
 4. Conductors No. 8 and larger and as otherwise noted on drawings shall be stranded. Conductors No. 10 and smaller shall be solid.
 5. Provide signal system wiring for each system to meet the system manufacturers requirements and recommendations for each device or equipment type. Signal wiring systems shall be provided with shielding and/or insulation type and cable quantities as directed by the manufacturer, and meet all NEC requirements for locations used.
 6. Install all wiring branch circuits and feeders (low voltage and line voltage) in conduit unless noted otherwise in the drawings. Contractor shall mandrel all feeders and pass a "sock" (or utilize other suitable means) through each raceway prior to pull to remove all water and construction debris. All raceways shall be completely clear of any obstructions or debris and all cut ends shall be reamed, prior to pull. Utilize pulling compound on all runs to insure minimum friction and pulling tension.
 7. Megger test all feeders prior to energizing. See section 26 08 00 for additional information.
 8. Approximately balance branch circuits about the neutral conductors in panels.
 9. Connections to devices from "thru-feed" branch circuit conductors to be made with pigtails, with no interruption of the branch circuit conductors.
 10. Neutral conductor identified by white outer braid, with different tracers of "EZ" numbering tags used where more than one neutral conductor is contained in a single raceway.

11. Neatly arrange and "marlin" wires in panels and distribution panelboards with "T and B Ty-rap" or approved equal plastic type strapping.
12. All wire and cable shall bear the Underwriters' Label, brought to the job in unbroken packages; wire color-coded as follows:

| Voltage | Phasing | A | B | C | N |
|---------|---------|-------|--------|--------|-------|
| 120/208 | 3PH4W | Black | Red | Blue | White |
| 2083PH | 3W | Black | Red | Blue | -- |
| 277/480 | 3PH4W | Brown | Orange | Yellow | White |
| 4803PH | 3W | Brown | Orange | Yellow | -- |

13. The equipment grounding conductor shall be insulated copper; where it is insulated, the insulation shall be colored green.
 14. Label each wire of each electrical system in each pull box, junction box, outlet box, terminal cabinet, and panelboard in which it appears with "EZ" numbering tags indicating the connected circuit numbers.
 15. Provide permanently affixed adhesive labels with machine printed lettering (min. 1/8" high) at junction boxes serving fixtures that are supplied by (2) electrical sources (i.e. normal and emergency lighting). Label to read "CAUTION - This light fixture is powered by (2) separate sources. The normal power source breaker and the emergency power source breaker must be turned off before servicing this light fixture."
 16. Install feeder cables in one continuous section unless splices are approved by Architect. Exercise care in pulling to avoid damage or disarrangement of conductors, using approved grips. No cable shall be bent to smaller radius than the spool on which it was delivered from the manufacturer. Color code feeder cables at terminals. Provide identifying linen tags in each pullbox.
- D. Switches: Model numbers are Hubbell, color to be selected by architect, unless otherwise noted. All switches to utilize screw terminals for wire connections - no plug-in terminations:
1. Single Pole - No. HBL1221
 2. Two Pole - No. HBL1222
 3. Three Way - No. HBL1223
 4. Momentary contact - No. HBL1557
 5. Momentary contact Keyed - No. HBL1556L
 6. Keyed, - No. HBL1221L
 7. Pilot Light (on with load on) - Hubbell No. 1221-PLC
 8. Motor Rated Double Pole (30A) - Hubbell No. 7832
 9. Motor Rated Three Pole (30A) - Hubbell No. 7810.
 10. Low voltage Data line switches - Refer to lighting control system (for compatibility)
- E. Receptacles: Mounting straps and contacts shall be one piece design, constructed of minimum .050" solid brass. Base shall be high strength, heat resistant, glass reinforced nylon. Device shall accept up to #10 wire, side or back wired with screw terminals - no plug-in terminations. Hubbell, Leviton, Pass & Seymore, or equal. Color to be selected by architect, unless otherwise noted. Numbers listed below are Hubbell:
1. 20A 3PG 125 volt duplex - No. HBL5362
 2. 20A 3PG 125 volt ground fault interrupter receptacle; GFI receptacles shall conform to the 2006 UL requirements to a) interrupt power to the unit in the event of internal failure, or b) provide an audible or visual indication of internal failure of the GFI; No. GF20 or equal. Through wiring to down stream GFI designated receptacles is not acceptable.
 3. All receptacles located in exterior or wet locations shall be corrosion resistant with UV stabilized body.
- F. Plates: Leviton, or equal, except as noted:

1. The color of all faceplates shall match the color of the devices installed under/in the faceplate, except as specifically noted otherwise.
 2. For flush outlet boxes, for switches, and receptacles: nylon, color to be selected by architect, unless otherwise noted.
 3. Plates for surface-mounted outlets: galvanized steel unless otherwise noted.
 4. Weatherproof duplex receptacle plates for exterior locations with ground fault interrupter receptacles in type FS or FD boxes - Appleton #FSK-1VDR or compatible equal. Verify cover compatibility with box type and device installed.
 5. Weatherproof "in-use" cover, vertical or horizontal mount, for exterior with GFCI receptacles. Die-cast metal alloy, Taymack MX series or equal with openings to match installed devices.
 6. Locking plates for duplex receptacles where noted; Pass & Seymour #WP26-L (non weather proof).
 7. Locking plates for duplex exterior GFCI receptacles (or in wet or damp locations); Heavy duty cast aluminum flush cover with locking latch and key, Pass & Seymour #4600 with appropriate mounting plate for type of device installed. Coordinate backbox requirements and finished wall trim-out with wall installer prior to rough-in to insure an adequate and neat trim appearance upon completion.
 8. Plates for flush telephone / data boxes: white nylon or as otherwise directed - provide and install at each telephone / data outlet plate to match duplex power outlet plate, for jack installation by others. Where the power and telephone / data outlet boxes are shared the plate shall be continuous in multi-gang locations. See drawings.
- G. Equipment Disconnects: All disconnects shall be located to allow proper code required clearance in each area. Locations shown on drawings are diagrammatic only. The contractor shall coordinate exact locations in the field (with other trades) prior to rough-in to insure proper clearances.
1. Motor Disconnect Switches and Safety Switches: General Electric Company Heavy Duty Type "THD", cover interlocked with operating handle so that cover cannot be opened with switch in closed position and switch cannot be closed with cover in open position. 240V or 480V rating, single or multi-pole as required or as noted on drawings, in Nema 1 enclosure indoors or Nema 3R enclosure outdoors unless otherwise noted. Provide dual element motor circuit fuses sized as recommended by equipment manufacturer (for final equipment actually installed).
 2. Code required disconnects: Provide a local disconnect in addition to the branch circuit protection device for all equipment as required by code (whether shown or not). Disconnects shall consist of a motor rated switch (or disconnect) for all motor loads less than 3/4HP or other suitable disconnect sized to match branch circuit conductors and load current of equipment, with number of poles as required.
- H. Lugs and Connectors: Thomas and Betts "lock-tite", for No. 4 and larger wire; 3M "Scotchlock" fixed spring screw-on type wire connectors with insulator for No. 6 and smaller wire.
1. All splices shall be made up with screw-on type connectors - no plug-in or push-in style connectors acceptable. Wires shall be solidly twisted together with electricians pliers before screw-on connector is installed to ensure a proper connection in the event of wire nut failure. No exceptions.
 2. Connectors listed or labeled for "no wire twisting required" are not an acceptable substitute for actual wire twisting.
 3. Utilize porcelain type connectors in all high temperature environments (above 105 degrees Celsius).
- I. Splice Insulation: "Scotch" electrical tape with vinyl plastic backing or rubber tape with protective friction tape for interior work.

1. Splices in electrical cables of 600 volt insulation class in underground system duct shall be made only in accessible locations such as pullboxes, light pole handholes, etc., using a compression connector on the conductor and by insulating and waterproofing (for exterior and underground locations) by one of the following methods:
 - a. Cast type splice insulation shall be provided by means of a molded casting process employing a thermosetting epoxy resin insulating material which shall be applied by a gravity poured method or by a pressure injected method. The component materials of the resin insulation shall be in a packaged form ready for convenient mixing after removing from the package. Do not allow the cables to be removed until after the splicing material has completely set.
 - b. Gravity poured method shall employ materials and equipment contained in an approved commercial splicing kit which includes a mold suitable for the cables to be applied. When the mold is in place around the joined conductors, the resin mix shall be prepared and poured into the mold. Do not allow cables to be moved until after the splicing materials have completely set.
- J. Identification: Refer to Section 26 05 00.
- K. Firestopping: as manufactured by 3M Fire Protection Products or equal.
 1. Fire-rated and smoke barrier construction: Maintain barrier and structural floor fire and smoke resistance ratings including resistance to cold smoke at all penetrations, connections with other surfaces or types of construction, at separations required to permit building movement and sound vibration absorption, and at other construction gaps.
 2. Systems or devices listed in the UL Fire Resistance Directory under categories XHCR and XHEZ may be used, providing that it conforms to the construction type, penetration type, annular space requirements and fire rating involved in each separate instance, and that the system be symmetrical for wall penetrations. Systems or devices must be asbestos free.

PART 3 - EXECUTION

3.01 REFER TO BASIC ELECTRICAL REQUIREMENTS - SECTION 26 05 00 FOR WORK UNDER THIS SECTION.

3.02 TESTS

- A. Testing and Inspection: See Section 26 08 00 - Testing.

END OF SECTION

SECTION 26 5101
LIGHTING

PART 1 - GENERAL

1.01 WORK INCLUDED

- A. Luminaires (i.e., lighting fixtures): Refer to the Luminaire Schedule and provide a complete and working facility Lighting System. Catalog numbers in the Luminaire Schedule are design series references and may not represent the exact catalog number as specified or as required for particular installations. Provide complete luminaires to correspond with the number of LEDs, power supply, wattage, mounting hardware, ceiling type, trim, size, and special requirements as specified in the Luminaire Schedule for each luminaire type. Additional features, accessories, and options specified, described, or scheduled shall be included.
- B. LEDs and power supplies.
- C. Lighting controls, including occupancy sensors. See Section 26 5700 for Low Voltage Lighting Control System.
- D. Exit and Emergency Egress lighting where indicated and where required.
- E. Supports for outlet boxes and luminaires, including seismic restraint slack wires for recessed luminaires in suspended ceilings per code and backing in walls as required to keep luminaires secure and level.

1.02 INCORPORATED DOCUMENTS

- A. Drawings and general provisions of the Contract, including General and Supplementary Conditions and other Division 1 Specification Sections, apply to this section.
- B. Section 26 05 00 and 26 27 00 apply to all work in this section.
- C. Division 03: Concrete (Bases for pole-mounted luminaires as noted in Luminaire Schedule).
- D. Division 09: Painting and Finishes (cutting of holes in finished surfaces for recessed luminaires).

1.03 RELATED WORK

- A. Ceiling Access panels where required for access to equipment, outlets, transformers, etc., located above suspended ceilings, sheet rock or plaster ceilings. Coordinate with the Architect and other trades.

1.04 SUBMITTALS

- A. Submit under provisions of Division 1 and Section 26 05 00.
- B. Submit (6) six sets of submittals for review by the project team unless otherwise noted in these specifications. The submittals shall include the following information:
 - 1. Product Index: The following information shall be included in the product index.
 - a. Luminaire Type. The index shall list, in alphabetical order, each luminaire type per the Luminaire Schedule.
 - b. Manufacturer's Catalog Number. Outstanding information required to make a complete catalog number shall be clearly identified in the index.
 - c. Where a pole is included with the luminaire, include the catalog number of the pole in addition to that of the luminaire.
 - d. LED Data. Provide the Manufacturer's name for each LED array including wattage, color temperature, lumen output, and color rendering index.
 - e. Comments. The index shall include a column or rows for comments. Comments include additional information required for clarity.
 - 2. Manufacturer's literature for every luminaire listed on the Luminaire Schedule.

- a. Catalog Information:
 - 1) Luminaire Data Sheet: The manufacturer's cut sheet shall include the following:
 - (a) Photometrics: Candlepower distribution curve or table with horizontal readings at 0, 22.5, 45, and 90 degrees and vertical readings from 0 to 180 degrees in 5 degree increments in accordance with the Illuminating Engineering Society published test procedures.
 - (b) Catalog Number Nomenclature
 - (c) Coefficient of Utilization Tables
 - (d) Luminaire Line Drawing
 - (e) Power supply (each type)
 3. Data sheets for electronic ballasts and power supplies. Indicate luminaire types on applicable ballast/power supply data sheets.
 4. Data sheets for wallbox controls and other products specified in this section.
 5. Shop Drawings:
 - a. Provide shop drawings of suspension details for luminaires recessed in, mounted on, or suspended from hung ceilings. Details shall clearly illustrate proposed methods for supporting luminaires independent of the suspended ceiling system.
 - b. Detailed shop drawings of all cove or box mounted luminaires containing the following information:
 - 1) Exact field measured length (clear inside dimension) of cove pocket or box.
 - 2) Exact luminaire length and arrangement of luminaires in cove or box.
 - c. Detailed shop drawings of pendant mounted luminaires constructed with linear metal housings containing the following information.
 - 1) Support mechanism, including swivel canopies.
 - 2) Trim details.
 - 3) Closure piece details.
 - 4) Pattern configurations.
 - d. Provide shop drawings for the following luminaire types:
 - 1) Indicate specific luminaire types that require shop drawings.
- C. For Any Luminaires Substituted For Those Specified:
 1. Refer to Division 1 - Product Requirements, for all substitution procedures.
 2. Provide independent testing laboratories, Inc., or equal, photometric test report for each Luminaire type and lamp combination listed on the Luminaire Schedule. Test reports shall be based on Illuminating Engineering Society published test procedures and shall contain polar coordinate candlepower distribution curves in five lateral planes for luminaires with asymmetric distributions and luminaire luminance data for vertical angles above 45 degrees from nadir. Test results shall indicate luminaire efficiency for the lamp and aperture assembly specified. luminaires with efficiencies more than 2% below the values of specified luminaires are not acceptable and will be rejected.
 3. Provide photometric calculations for each room or area where a substituted luminaire is proposed. Such calculations shall be made using comprehensive lighting software, such as AGi32, and include point-by-point illuminance values at IES recommended heights, average illuminance, and maximum-to-minimum and average-to-minimum uniformity ratios. Room dimensions, configurations (including sloping ceilings), room surface reflectances, light loss factors, and heights of suspended luminaires shall match the heights specified in the contract documents.
 4. Due to the variety of lumen outputs and light distributions of LED Luminaires, substitutions will require additional review on the part of the Engineer or Architect to ascertain the equivalency of the substituted luminaires. Substitutions will be reviewed to determine their aesthetic, construction, and photometric equivalency to maintain similar

design impact and performance in their intended environment. The Engineer and Architect have not included such unknown and unquantifiable review time in their scope of work and are not compensated by the Owner for such services. The Contractor shall reimburse the Engineer and Architect for labor costs to review substitutions.

5. Prior approval does not guarantee final approval by the Engineer. The Contractor shall be responsible for providing luminaires that meet or exceed the quality and performance of the specified products in their entirety. All deviations in quality and performance from the specified products must be listed and individually signed off by the engineer.
6. The Owner reserves the right to reject a proposed substitution based on their agent's professional judgment as to the utility, quality, performance, visual appropriateness, or finish of substitutions.

1.05 OCCUPANCY SENSORS

A. Equipment Qualification

1. Wall switch products must be capable of withstanding the effects of inrush current. Submittals shall clearly indicate the method used.
2. Contractor's work to include all labor, materials, tools, appliances, control hardware, sensor, wire, junction boxes and equipment necessary for and incidental to the delivery, installation and furnishing of a completely operational occupancy sensor lighting control system, as described herein.
3. Contractor/Supplier shall examine all general specification provisions and drawings for related electrical work required as work under Division 26.
4. Contractor shall coordinate all work described in this section with all other applicable plans and specifications, including but not limited to wiring, conduit, luminaires, HVAC systems and building management systems.

1.06 DELIVERY, STORAGE, AND HANDLING

- A. Deliver products to site and store in unopened cartons in protected location. Inspect products immediately and report all damage accordingly.

1.07 GUARANTEE AND WARRANTIES

- A. All work performed under this section must be guaranteed to be free of defects in products or workmanship for one year after date of acceptance by Owner, unless noted otherwise in General Conditions.
- B. Warranties:
 1. Electronic ballasts and power supplies must be warranted against failure for at least five years after date of substantial completion.

PART 2 - PRODUCTS

2.01 GENERAL

- A. Provide luminaires as indicated in Luminaire Schedule; if conflict exists between Luminaire Schedule and Specifications, the more stringent requirement shall take precedence.
- B. Provide luminaires new and complete with mounting accessories, junction boxes, trims, and lamps.
- C. Provide products with UL labels appropriate to intended installation conditions, or with labels from other testing laboratories whose results are acceptable to local inspector, showing compliance with UL standards. Labels must be concealed from normal viewing angles.
- D. All products of same type by same manufacturer.

2.02 SOLID STATE LUMINAIRES

- A. Housing, where applicable:

1. Steel bonderized or equal rust protected, or aluminum, rigid construction. Minimum gauge thickness shall be as follows:
 - a. Interior locations: No. 20-gauge steel, No. 16-gauge aluminum.
- B. Finish:
 1. Baked enamel finish (except when otherwise specified).
 - a. Concealed interior surfaces (this applies to interior hardware, circuit boards, etc.) matte black.
 - b. Concealed exterior surfaces: matte black.
 - c. Visible surfaces: color and texture as specified below for each luminaire type or as selected.
- C. Light Emitting Diode (LED) requirements:
 1. Correlated color temperature (CCT) for phosphor-coated white LEDs must have one of the following designated CCTs, as specified on the Luminaire Schedule, and fall within the following binning standards.
 - a. 3000K defined as 3045 +/- 175K
 - b. 3500K defined as 3465 +/- 245K
 - c. 4000K defined as 3985 +/- 275K
 2. Color spatial uniformity shall be limited to variations in chromaticity for different directions (i.e. changes in viewing angle) within 0.004 from the weighted average point on the CIE 1976 (u',v') diagram.
 3. Color maintenance shall be limited to a maximum change in chromaticity of 0.007 on the CIE 1976 (u',v') diagram over the lifetime of the product.
 - a. Color rendering index: Color rendering index to be determined using ANSI C78.377-2008 and applicable IESNA standards.
 - b. Laboratory tests must be produced using specific module(s)/array(s) and power supply combination that will be used in production.
 - c. Manufacturers must provide a test report from a laboratory accredited by NVLAP or one of its MRA signatories
 4. Lumen depreciation
 - a. Lumen depreciation to be measured using IESNA LM-80-08 and TM-21-11 standard for IES approved method of measuring lumen maintenance of LED light sources.
 - b. Phosphor-coated white LED modules/arrays shall deliver at least 70% of initial lumens for a minimum of 50,000 hours when installed in-situ and operated at 100% output and the maximum specified operating temperature.
 - c. Colored LED modules/arrays shall deliver at least 50% of initial lumens for a minimum of 50,000 hours when installed in-situ and operated at 100% output and the maximum specified operating temperature.
 5. Acceptable LED manufacturers:
 - a. Cree
 - b. Nichia
 - c. Osram Opto Semiconductors
 - d. Philips Lumileds
 - e. Soraa
 - f. Xicato
- D. Luminaire Efficacy:
 1. Luminaire efficiency shall be measured using IESNA LM-79-08 standard for electrical and photometric measurements of solid state lighting products.

2. Manufacturer shall provide published luminaire efficacy, which is defined as luminaire light output divided by luminaire input power measured in a 25 degree Celsius environment. Efficacy shall include power supply, thermal, optical, and luminaire losses.
- E. Thermal Management:
1. Solid state luminaire shall not exceed LED manufacturer's maximum junction temperature requirements when operated in-situ at luminaire manufacturer's maximum ambient operating temperature and 100% light output.
 2. Solid state luminaires shall be thermally protected using one or more of the following thermal management techniques:
 - a. Metal core board
 - b. Gap pad
 - c. Internal monitoring firmware
 3. Solid state luminaire housing shall be designed to transfer heat from the LED board to the outside environment.
- F. Power Supplies (LED Drivers) requirements:
1. Power factor of 0.90 or greater for primary application
 2. Input current shall have Total Harmonic Distortion (THD) of less than 20%.
 3. Minimum operating temperature of minus 20 degrees Celsius or below when used in luminaires intended for outdoor applications.
 4. Operating frequency equal to or greater than 120 Hz.
 5. Operate with sustained input variations of +/- 10% (voltage and frequency) with no damage to the driver.
 6. Tolerate sustained open circuit and short circuit output conditions without damage and without need for external fuses or trip devices.
 7. Output shall be regulated to +/- 5% across published load range.
 8. Class A sound rating.
 9. Outputs shall have current limiting protection.
 10. Operate LEDs at constant and regulated current levels. LEDs shall not be overdriven beyond the diode manufacturer's specified nominal voltage and current.
- G. Solid State Lighting Controls:
1. Control interface to dimmable power supplies shall consist of one of the following:
 - a. Line Voltage Dimming. Controls to be rated for magnetic or electronic low voltage transformer operation.
 - b. Low voltage (0-10V) control. Controls to be compatible with either current sink or current source operation.
 - c. DMX control
 2. Dimmable LED power supplies shall use pulse width modulation (PWM) or constant current reduction (CCR) to regulate power to LEDs.
 - a. PWM power supplies shall have 12-bit or greater resolution to obtain flicker-free operation throughout their dimming range.
 - b. PWM power supplies shall be provided in luminaires that will be dimmed lower than 40% and must maintain consistent color temperature.
 - c. CCR power supplies shall be provided in areas that have strict electromagnetic interference (EMI) requirements, high motion activity, or rotating machinery.
- H. System Installation
1. Hardwired connections to solid state luminaires shall be reverse polarity protected and provide high voltage protection in the event connections are reversed or shorted during the installation process.

2. All solid state luminaires (100% of each lot) shall undergo a minimum eight-hour burn-in test during manufacturing. Solid state lighting installations shall be UL Listed as a low-voltage lighting system including, but not limited to, luminaire, power supply, controller, keypad, and wiring.

I. Warranty

1. Luminaires, drivers, and controllers for solid state lighting systems shall be covered by a five-year warranty against defects in workmanship or material. Warranty shall include in-warranty service program providing for payment of authorized labor charges incurred in replacement of inoperative in-warranty equipment.

2.03 LUMINAIRE CONSTRUCTION

- A. Sheet metal: materials and thicknesses shall be 20 gauge (0.7 mm or 0.027") min., free of dents, scratches, oil-can, or other defects.
- B. Painted luminaires: exposed weld marks, joints, and seams shall be filled and sanded smooth before finishing.
- C. All edges cleaned and dressed to remove sharp edges or burrs.
- D. Extrusions: 1/10" min. wall thickness, smooth and free of tooling lines, with cast end plates that exactly match extrusion profiles.
- E. Castings: smooth, free of pits, scales, gate marks, or blemishes.
- F. Spinings shall have 1/32" min. thickness, smooth, free of spinning lines or blow-back, with clean edges.
- G. Welds: Follow recommendations of American Welding Society. All welds continuous and free of spatter, residue, or warping.
- H. No light leaks visible in finished room. Ensure that downlight housings mounted in wood slat ceilings are not visible from below. Field paint exterior of housing with high temperature paint if necessary.
- I. Exposed end plates and joiners, with concealed fasteners.
- J. End-to-end mounted luminaires: Verify row configurations and provide joiners, aligning splines, and trims to suit.
- K. Hardware:
 1. Steel or aluminum interior luminaires: cadmium-plated hardware.
 2. Steel or aluminum exterior luminaires: stainless steel hardware.
 3. Stainless steel luminaires: stainless steel hardware.
 4. Copper alloy luminaires: brass hardware.
- L. Raceways: Where used for through wiring, luminaires must be approved for use as raceways.

2.04 RECESSED LUMINAIRES

- A. Point-source luminaires: provide pre-wired junction box and thermal protection, and provide slack wires to structure at two diagonal corners.
- B. Troffer luminaires: provide hold-down clip at each luminaire corner, and slack wires to structure as detailed on the drawings. The detail will take precedence.
- C. Verify ceiling construction details and provide luminaire housings and trims to suit.
- D. Non-accessible ceilings: Provide access to junction boxes, ballasts, transformers, and battery packs through luminaire apertures; no access panels in ceiling.
- E. Mounting frames: To prevent rusting, provide galvanized steel or cast aluminum frames for installation in damp locations or in plaster ceilings.
- F. Adjustable luminaires shall be provided with rotation and tilt locking devices.

2.05 PENDANTS

- A. Stem-mounted: 16 mm (5/8") max. o.d. stem with ball swivels at top (and bottom of linear luminaires) to permit 45 degree swing in any direction from vertical. Flat canopy to permit splice inspection after installation. Pendants must permit +/- 13 mm (1/2") threaded vertical adjustment after installation, leaving at least 6 mm (1/4") thread contact at all points.
- B. Provide internal safety cable from luminaire body to stud in outlet box.
- C. Cable-mounted: 1 X 7 strand 3/32" diameter stainless steel aircraft cable, factory crimped, independently tested and verified to exceed 1500 pounds.
 - 1. Verify mounting heights for each luminaire and provide cable lengths and coordinate cord lengths with manufacturer as required prior to ordering luminaires. Provide aircraft cable adjuster nipple with locking jaws.
- D. Supports: Carry luminaire weight to structure and provide horizontal bracing from suspension points to ceiling framing to prevent sideways shifting. Provide diagonal seismic restraint wires per code.

2.06 TRIMS

- A. Trims must fit tightly and be held in by gravity, spring clips, or mechanical fasteners. Trims must not drop out under normal conditions or seismic forces which do not exceed the design criteria of the building.
- B. Aluminum parabolic cones shall be smooth, properly shaped, with Alzak finish in colors as indicated.
 - 1. No hot spots or lamp images visible at angles shallower than lamp shielding angle.
 - 2. Self-flange cones must bend parallel to ceiling and cover ceiling hole without additional trim ring. Unpainted flange, shall have the same finish as cone interior.
 - 3. Cones and louvers for fluorescent luminaires must have permanent anti-iridescence treatment.
- C. Lenses, diffusers, and patterned glass: glass or virgin acrylic as noted, with patterns as noted.
 - 1. Finished thickness 2 mm (1/10") min. unless noted otherwise.
 - 2. Linear runs over 1200 mm (4'-0") long shall be in equal-length pieces.

2.07 FINISHES

- A. Steel Reflectors: Unless otherwise specified, the reflector surface finish shall be of synthetic white enamel or polyester powder coating. Finish shall show no indication of chipping, cracking, flaking or any other sign of loss of adhesion. The initial reflection factor shall be not less than 88 percent averaging 5 randomly selected points on the reflector. After 100 hours of exposure to the radiation of a glass enclosed carbon arc lamp, such as a Fade-O-Meters, the reflectance of the exposed portion shall not be less than 5 percent and finish shall show no appreciable color change. The carbon arc lamp shall be operated at appreciable color change. The carbon arc lamp shall be operated at 13 plus or minus 0.5 amperes at 140 volts. The reflector shall be placed ten inches from the arc and the lamp so ventilated that the temperature of the exposed portion does not exceed 105 degrees F.
- B. Aluminum Reflectors: Reflecting surfaces shall be provided with either a specular or diffuse finish as indicated. Reflection factors shall be not less than 83 percent for specular reflecting surfaces. Each reflecting surface shall be protected by dense coating of oxide weighing not less than 5.0 milligrams per square inch, applied by an anodic process. The reflector shall be given a sealing treatment that will prevent staining of the reflecting surface when subjected to a stain test. All aluminum reflectors & louvers shall be a low iridescent equivalent to that provided by Coil Anodizers.

- C. Non-Reflecting Surfaces: Unless otherwise specified, the finish on all non-reflecting exterior surfaces shall be aluminum oxide or aluminum; white, gray or aluminum paint on steel; nickel or chromium plating on copper alloy. Fastening devices shall be nickel, chromium, cadmium or zinc plated. All painted surfaces shall be free of tears, star marks, blisters, pinholes, chipping and any other defects that may impair appearance or serviceability.

2.08 LAMPS

- A. Relamp luminaires or replace LED boards and power supplies at no cost to owner if lamps or LEDs exhibit color variation, flicker, or burn out within 90 days of substantial completion date.
- B. LEDs:
 - 1. LED quantity, wattage, and color temperature as specified for each LED luminaire.
 - 2. 3500 deg. K color temperature for interior luminaires, 3000 deg. K for exterior luminaires, unless otherwise specified.

2.09 BALLASTS, DRIVERS, AND TRANSFORMERS

- A. General:
 - 1. Verify input voltages and match to branch circuit voltages.
 - 2. Provide ballasts with best-made sound ratings for each type and mount securely to prevent vibration.
 - a. Replace excessively noisy ballasts or transformers at no cost to Owner.
 - 3. Remote ballasts or transformers: Provide suitable enclosures and mounting hardware, and install in accessible, ventilated locations.
 - a. Secondary wiring: provide number and size of conductors as required, with 3% max. voltage drop between transformer and last lamp.
 - b. Keep ballasts or transformers at least 300 mm (12") apart and do not stack vertically.
 - 4. Ballasts must contain no PCB's and be labeled accordingly.
- B. LED Drivers:
 - 1. High power factor, thermally-protected.
 - 2. Compatible with LED lamps being used.
 - 3. Capable of dimming LED source without perceptible flicker or stroboscopic effects.

2.10 EMERGENCY LIGHTING AND EXIT SIGNS

- A. Emergency lighting:
 - 1. Provide lighting for paths of egress as required by Code.
- B. Description of Systems:
 - 1. Auxiliary battery pack/ballasts mounted integral to luminaires shall provide no less than 1400 lumen output for a minimum of 90 minutes.
 - 2. Surface mounted luminaire with two (2) MR16 lamps on emergency battery with 90 minute operation.
- C. Auxiliary Battery Pack/Ballasts for Fluorescent or LED Luminaires:
 - 1. Pure lead or nickel-cadmium, sealed and maintenance-free.
 - 2. Automatic transfer to battery power if supply voltage drops below 75% of normal.
 - 3. Must provide at least 87-1/2% or rated battery voltage for 90 minutes minimum.
 - 4. Internal circuitry to provide continuous "trickle" charge and to prevent deep discharge below 80% of rated battery voltage.
 - 5. Full recharge within 24 hours after restoration of normal power.
 - 6. Charge indicator light visible and test switch operable without tools.
 - 7. Concealed inside luminaire or above ceiling, but replaceable through luminaire aperture.
 - 8. Designed to run one or two lamps per luminaire with minimum of 1400 lumen output.
 - 9. Acceptable manufacturers: Bodine, Dual-Lite, Emergi-Lite, Lithonia, Radiant, Siltron.

- D. Recessed emergency luminaire:
 - 1. Cold rolled steel housing.
 - 2. 12v sealed permanent magnet type motor with 30 yr. Service life.
 - 3. Solid state electronics.
 - 4. Integral test switch and pilot light to indicate charge rate.
 - 5. Acceptable manufacturers: Concealite.
- E. Exit signs shall be edge or back lit LED, surface-mounted on ceiling or wall, with integral battery packs as described above.
 - 1. Fabricated aluminum construction, no light leaks around canopy. Plain box, with no decorative trim.
 - 2. Letters shall be 20mm (3/4") stroke, 150 mm (6") high, with concealed knockouts for left or right arrows, brightness and evenness of illumination per code, green color.
 - a. Battery pack contained in basic luminaire housing. No add-on packs or canopies.
 - b. Green LED lamps located at interior perimeter for indirect illumination of stencil letters.
 - c. Provide finish as specified in the Luminaire Schedule.
 - d. Knock out the arrows as indicated on the plans.
- F. Emergency luminaires supplied by a separate emergency power source.
 - 1. For luminaires supplied by a separate emergency power source, provide "switched" control of the emergency designated lamps to allow complete "off" control when required by the user. The switched control shall include an automatic transfer feature to automatically turn "on" the emergency designated lamps upon the normal source power failure.
 - 2. Automatic transfer function shall be provided using a UL 924 listed relay, LVS Inc. #EPC-A or equal, suitable for mounting in a standard 4" square j-box (min. 2.5" deep). Transfer relay shall provide automatic diagnostic test feature which shall maintain power to the emergency designated lamps for 15 seconds after the room is switched off via the respective light switch or control relay. Emergency designated lamps shall turn off after the 15 second test period and shall come back on when the control device is turned back on to restore full lighting to the space.
 - 3. Provide (1) transfer module per "switched" zone.
- G. Emergency luminaires supplied by a dimmer panel and/or emergency source.
 - 1. For luminaires supplied by a dimmed power source, provide "dimmed" control of the emergency designated lamps to allow normal dimming control with the normal lamps. The dimmed control shall include an automatic transfer feature to automatically turn "on" the dimmed lamps to full light output upon the normal source power failure.
 - 2. Automatic transfer function shall be provided using a UL 924 listed relay, LVS Inc. #EPC-D (2-wire dimmed), #EPC-D-U (3-wired dimmed) or equal, suitable for mounting in a standard 4" square j-box (min. 2.5" deep).
 - 3. Provide (1) transfer module per "dimmed" zone.
 - 4. For DMX-controlled LED emergency lighting, provide control bypass, ETC DEBC series with emergency bypass detection kit - quantity of DEBC outputs as indicated on drawings.

2.11 WALL-BOX DIMMERS

- A. Provide dimmer controls as specified on the drawings and in Specifications Section 26 57 00.
- B. Ganging and Labeling:
 - 1. Dimmers and matching switches in same location shall be installed in same gang box.

2. Follow dimmer manufacturer's instructions for gang-box sizes. Do not break off fins on dimmers unless noted otherwise.
 - a. 1+1, 4+1, 7+1 installation: to gang an even number of small devices without breaking off fins, provide multi-gang box as indicated (1, 4, or 7 gangs) and provide additional single-gang box at end, with ears of single box 70 mm (2-3/4") o.c. from last set of ears on multi-gang box.
 - b. When rows of devices are stacked vertically space rows 230 mm (9") o.c. to allow heat dissipation.
3. Provide Lutron multi-gang plates to cover each group of devices.
4. Plates with "-NFB" in catalog number with no fins broken.
5. Plates with "-FB" in catalog number: break off all interior fins on devices, but do not break off outside fins at either end of row.
6. Nova-T: install aligning backplate (provided by Lutron with each multi-gang plate) between wall and devices.
7. Labels: text as indicated 3 mm (1/8") high, all capital letters, engraved on device faceplate, filled with black paint and wiped clean.

2.12 OCCUPANCY SENSORS

A. General

1. Wall switch sensors shall be capable of detection of occupancy at desktop level up to 300 square feet, and gross motion up to 1000 square feet.
2. Wall switch sensors shall accommodate loads from 0 to 800 watts at 120 volts; 0 to 1200 watts at 277 volts and shall have 180° coverage capability.
3. Wall switch products shall utilize Zero Crossing Circuitry which increases relay life, protects from the effects of inrush current, and increases sensor's longevity.
4. Wall switch sensors shall have no leakage current to load, in manual or in Auto/Off mode for safety purposes and shall have voltage drop protection.
5. Where specified, wall switch sensors shall provide a field selectable option to convert sensor operation from automatic-ON to manual-ON.
6. Where specified, vandal resistant wall switch sensors shall utilize a hard lens with a minimum 1.0mm thickness. Products utilizing a soft lens will not be considered.
7. Passive infrared sensors shall utilize Pulse Count Processing and Digital Signature Analysis to respond only to those signals caused by human motion.
8. Passive infrared sensors shall utilize mixed signal ASIC which provides high immunity to false triggering from RFI (hand-held radios) and EMI (electrical noise on the line), superior performance, and greater reliability.
9. Passive infrared sensors shall have a multiple segmented Lodif Fresnel lens, in a multiple-tier configuration, with grooves-in to eliminate dust and residue build-up.
10. Where specified, passive infrared and dual technology sensors shall offer daylighting foot-candle adjustment control and be able to accommodate dual level lighting.
11. Dual technology sensors shall be corner mounted to avoid detection outside the controlled area when doors are left open.
12. Dual technology sensors shall consist of passive infrared and ultrasonic technologies for occupancy detection. Products that react to noise or ambient sound shall not be considered.
13. Ultrasonic sensors shall utilize Advanced Signal Processing to adjust the detection threshold dynamically to compensate for constantly changing levels of activity and air flow throughout controlled space.
14. Ultrasonic operating frequency shall be crystal controlled at 25 kHz within $\pm 0.005\%$ tolerance, 32 kHz within $\pm 0.002\%$ tolerance, or 40 kHz $\pm 0.002\%$ tolerance to assure

reliable performance and eliminate sensor cross-talk. Sensors using multiple frequencies are not acceptable.

15. All sensors shall be capable of operating normally with electronic ballasts, PL lamp systems and rated motor loads.
16. Coverage of sensors shall remain constant after sensitivity control has been set. No automatic reduction shall occur in coverage due to the cycling of air conditioner or heating fans.
17. All sensors shall have readily accessible, user adjustable settings for time delay and sensitivity. Settings shall be located on the sensor (not the control unit) and shall be recessed to limit tampering.
18. In the event of failure, a bypass manual override shall be provided on each sensor. When bypass is utilized, lighting shall remain on constantly or control shall divert to a wall switch until sensor is replaced. This control shall be recessed to prevent tampering.
19. All sensors shall provide an LED as a visual means of indication at all times to verify that motion is being detected during both testing and normal operation.
20. Where specified, sensor shall have an internal additional isolated relay with Normally Open, Normally Closed and Common outputs for use with HVAC control, Data Logging and other control options. Sensors utilizing separate components or specially modified units to achieve this function are not acceptable.
21. All sensors shall have UL rated, 94V-0 plastic enclosures.

B. Circuit Control Hardware - CU

1. Control Units - For ease of mounting, installation and future service, control unit(s) shall be able to externally mount through a 1/2" knock-out on a standard electrical enclosure and be an integrated, self-contained unit consisting internally of an isolated load switching control relay and a transformer to provide low-voltage power. Control unit shall provide power to a minimum of two (2) sensors.
2. Relay Contacts shall have ratings of:
 - a. 13A - 120 VAC Tungsten
 - b. 20A - 120 VAC Ballast
 - c. 20A - 277 VAC Ballast
3. Control wiring between sensors and controls units shall be Class II, 18-24 AWG, stranded U.L. Classified, PVC insulated or TEFLON jacketed cable suitable for use in plenums, where applicable.
4. Minimum acceptable wire gauge from the circuit control hardware relays shall be #14 AWG.

C. Acceptable Manufacturers

1. The Watt Stopper, or Pre-Approved Equal: For pre-approval, provide all the information listed under "submittals" a minimum of ten (10) working days prior to initial bid date.
2. The listing of any manufacturer as "acceptable" does not imply automatic approval. It is the sole responsibility of the Contractor to ensure that any price quotations received and submittals made are for sensors that meet or exceed the specifications and the requirements of the contract documents.

PART 3 - EXECUTION

3.01 PREPARATION

- A. Architectural Reflected Ceiling Plans and Elevations shall govern exact location and mounting conditions for all luminaires. Contractor shall coordinate luminaire mounting and compatibility with ceiling construction and other trades.

- B. Coordinate work with other trades. Location of lighting has priority over location of new framing (except major structural members), ducts, diffusers, sprinklers, speakers, smoke detectors, and other obstructions.
- C. If obstructions are encountered which prevent installation of luminaires according to drawings, notify Architect immediately and do not proceed until conflict has been resolved.
- D. Coordinate the location of luminaires in mechanical or unfinished spaces. Locations shown on Drawings may be adjusted by the Contractor to suit conditions. Install luminaires to avoid obstructions and maximize light output, 2100 mm (7'-0") min. mounting height.
- E. In Elevator Machine Rooms, locate the luminaires so that the illumination level at the floor is not less than 200 lx (19 fc). Illuminate areas in front of and behind (if accessible) controllers, machines and other elevator equipment.
- F. In Elevator Pits, locate the luminaires so that the illumination level at the pit floor is not less than 100 lx (10 fc).
- G. Coordinate the location of any exposed conduit used to feed luminaires with the Architect prior to installation.

3.02 INSTALLATION

A. General:

1. Contractor shall be responsible for handling and installation of luminaires including all supports, hangers and hardware necessary for a complete installation. Luminaires shall be clean, plumb, level in straight lines, without distortion. Luminaires must be installed so they do not shift during relamping or adjustment. Remedy any light leaks which may develop after installation of recessed or enclosed luminaires.
2. Install luminaires at locations and heights as indicated, in accordance with luminaire manufacturer's written instructions, applicable requirements of NEC, NECA's "Standard of Installation", NEMA standards, and with recognized industry practices to ensure that luminaires fulfill requirements.
3. Point-source luminaires shall be located as dimensioned, or in center of tile or on tile joint as drawn; 6 mm (1/4") max. off-center tolerance.
4. Linear luminaires shall have 3 mm (1/8") max. horizontal or vertical alignment variation in any 5 m (16-ft.) portion of run.
5. Tighten connectors and terminals, including screws and bolts, in accordance with equipment manufacturer's published torque tightening values for equipment connectors. Where manufacturer's torqueing requirements are not indicated, tighten connectors and terminals to comply with tightening torques specified in UL Stds. 486 A and B, and the National Electrical Code.
6. Clean luminaires of dirt and construction debris upon completion of installation. Clean fingerprints and smudges from lenses.
7. Remove and replace luminaires that may have been damaged during construction at no additional cost to the Owner.
8. Protect installed luminaires from damage during remainder of construction period.
9. Provide equipment grounding connections for luminaires as indicated. Tighten connections to comply with tightening torques specified in UL 486 A to assure permanent and effective grounds.
10. Install luminaires, lamps, lenses, etc., after building is enclosed, weather tight and environmental conditions are nominally the same as expected for the complete spaces. All lenses, glass, reflectors, and refractors shall be clean and free of chips, cracks, and scratches.

11. All wall mounted luminaires and all ceiling mounted surface luminaires including exit lights shall be fed through a luminaire Stud/Hickey/Nipple assembly and with provisions to prevent luminaire turning.
 12. Installation of exit signs shall be coordinated with other trades to ensure signs are visible as intended.
 13. All junction box cover plates for the lighting branch circuit system shall be clearly marked with a permanent ink felt pen identifying the branch circuit and control relay (panel number, circuit number, lighting control cabinet designation and control relay number) contained in the box.
 14. Provide permanently affixed adhesive labels with machine printed lettering (min. 1/8" high) at junction boxes serving luminaires that are supplied by (2) electrical sources (i.e. normal and emergency lighting). Label to read "CAUTION - This luminaire is powered by (2) separate sources. The normal power source breaker and the emergency power source breaker must be turned off before servicing this luminaire."
- B. Recessed Luminaires:
1. The contractor shall verify the fire rating of the ceiling system and wall in which the luminaires are to be mounted. Where luminaires are installed in fire rated ceilings or walls, provide fire rated enclosures around and over luminaires to maintain ceiling fire rating. No additional cost shall be allowed for failure to include such enclosures and installation in the bid.
 2. Holes for Recessed Point-Source Luminaires: Cut holes to follow luminaire housings exactly so no gaps will be visible after trims are installed.
 3. Install bottom of housing aligned with finished ceiling.
 4. Keep ceiling insulation at least 75 mm (3") away from luminaires. Exception: luminaires with insulated contact (IC) rating shall be permitted to be in contact with insulation.
 5. Install trims after painting of spaces. Install trims tightly, with no gaps or light leaks.
 6. Seismic restraints: Provide and install slack wires and hold-down clips per code.
 7. Wallwashers:
 - a. Orient wallwasher housings according to manufacturer's instructions to maximize brightness on the upper portion of the wall.
- C. Ceiling-Mounted and Pendant Luminaires:
1. Provide support for outlet boxes and suspension points so luminaires can be installed securely, including seismic supports per code.
 - a. Luminaire weight less than 25 kg (50 lb.) at each suspension point: hang from strap or stud on outlet box, or at non-feed points, provide 1/4"-20 stud projecting 20 mm (3/4") below ceiling.
 - b. Luminaire weight 25 kg (50 lb.) or more at each suspension point: hang directly from structure, either independent of outlet box or from stud extending through outlet box to structure.
 2. Pendants:
 - a. Provide horizontal bracing from suspension points to ceiling framing to prevent sideways shifting.
 - b. Provide diagonal seismic restraint wires above ceiling per code.
 - c. Furnish suspended luminaires with universal joint type hanger canopy (and longitudinal sway adapter at each stem connection point for linear luminaires), to permit 45 degree swivel on 360 degree circle from Nadir at canopy (and 45 degree longitudinal movement at sway adapter).
 - d. Luminaires over 450 mm (18") wide shall be provided with supports at all corners.
 - e. Install pendants plumb and level.
 - f. Verify luminaire weights and provide backing in ceiling as required.

D. Wall-Mounted Luminaires:

1. Mounting heights shown on Drawings are measured from finished floor to centerline of outlet box or recessed housing, unless otherwise noted.
2. Verify luminaire weights and provide backing in wall as required. Luminaires must not droop or tilt away from wall.
3. Wet locations: install sealant between luminaire and outlet box.
4. In circulation areas, wall-mounted luminaires must not project more than 100 mm (4") from wall if mounted above 685 mm (27") and below 2030 mm (80").

3.03 LIGHTING CONTROLS

- A. Install controls so that all operable parts are at 48 inches (1220 mm) maximum height.
- B. Lighting controls to include occupancy sensors in most spaces (for local control) and relay system lighting control for larger common spaces as indicated on the drawings.
- C. Occupancy sensors shall initially be set as follows:
 1. Maximum sensitivity.
 2. Maximum time delay (or 30 minutes).
 3. Manual-on operation.
 4. Automatic off operation.
 5. Aim all adjustable sensors to properly cover room areas.

3.04 DELIVERY, STORAGE, & HANDLING:

- A. Deliver luminaires in factory-fabricated containers or wrappings, which properly protect luminaires from damage. Inspect luminaires immediately upon delivery to ensure correct shipment without damage.
- B. Store luminaires in original packaging. Store inside well-ventilated area protected from weather, moisture, soiling, extreme temperatures, humidity, laid flat and blocked off ground.
- C. Handle luminaires carefully to prevent damage, breaking, and scoring of finishes. Do not install damaged units or components; replace with new. Protection wrapping on louvered (parabolic) luminaires shall not be removed until luminaires are ready for operation.

3.05 SEQUENCING AND SCHEDULING:

- A. General:
 1. Coordinate with other work including wires/cables, electrical boxes and fittings, and raceways, to properly interface installation of luminaires with other work.
 2. Sequence lighting installation with other work to minimize possibility of damage and soiling during remainder of construction.

3.06 PROJECT CLOSEOUT

- A. Clean luminaires and remove plaster and paint spatters.
- B. Clean fingerprints and dust from downlight reflectors. Refer to manufacturer's instructions.
- C. Verify that luminaires and controls are working at time of final acceptance by Owner.
 1. Repair or replace lighting control devices that are inoperable.
 2. Repair or replace LED modules or entire LED luminaires that are inoperable.
 3. Repairs and/or replacements shall be at no additional cost to the Owner.
- D. Test emergency lighting system for 90 minutes in presence of Owner's representative, check each luminaire for proper operation at end of 90-minute test, then recharge for 24 hours and briefly test each luminaire again for proper operation.
- E. Install and aim adjustable lighting as directed by Architect.
 1. Provide personnel, lifts, ladders, and walkie-talkies as required.

2. Aiming will occur at night, outside of normal working hours, at times as approved by the Architect.
- F. Prepare two copies of a Lighting Systems Maintenance Manual consisting of the following in a hardcover binder. Deliver to Architect. After review, Architect will deliver one copy to Owner.
1. One complete set of approved submittals, including product data and shop drawings.
 2. Luminaire cleaning instructions, including chemicals to be used or avoided.
 3. Instructions for code-required testing and maintenance of emergency lighting system.

END OF SECTION

**SECTION 26 5601
SITE LIGHTING**

PART 1 - GENERAL

1.01 WORK INCLUDED

- A. Luminaires
- B. LED's
- C. Power Supplies/Drivers
- D. Poles
- E. Pole bases
- F. Controls and wiring

1.02 SYSTEM DESCRIPTION

- A. Furnish all labor, materials, apparatus, tools, equipment transportation, temporary construction and special or occasional services as indicated on the Drawings or described in these Specifications and as required to make a complete working site lighting system.
- B. Illumination levels shall be in accordance with recommendations by the Illuminating Engineering Society (IES).

1.03 INCORPORATED DOCUMENTS

- A. Section 26 05 00 and Section 26 51 01 apply to all work in this Section.

1.04 SUBMITTALS

- A. Catalog Information:
 - 1. Luminaire (each type) with photometric pattern.
 - 2. Contactors.
 - 3. Ballast or Driver (each type)
 - 4. Poles.
 - 5. Brackets.
- B. Shop Drawings.
- C. Manufacturer's Recommendations: Provide two copies before material is used.
 - 1. PVC conduit joints and junctions.
 - 2. Solvent welding directions.
 - 3. Pole bases.
- D. Laboratory Test: Determine soil density relationships for compaction of backfill material in accordance with ASTM D1557, Method D.

PART 2 - PRODUCTS

2.01 MATERIAL AND EQUIPMENT

- A. Provide new materials and equipment unless otherwise specifically indicated or specified. Materials shall be listed by Underwriter's laboratories, Inc. (U.L.) and bear evidence of such approval where applicable.
- B. Luminaires: Site luminaires shall be weatherproof. Reflectors and refractors shall provide the light configuration indicated and conforming to IES recommendations.
- C. Luminaires and poles shall be finished in epoxy enamel designed to withstand the effects of salt spray. Lens shall be securely attached to the lens frame for security during maintenance and relamping.

- D. Lighting Contactors: NEMA ICS 2. Electrically operated, magnetically held unit in NEMA enclosure, rated poles and ratings as indicated on Drawings. Units shall have silver alloy double breaker contacts and coil clearing contacts and shall require no arcing contacts. On-off selector switch.
- E. Ballasts: High intensity discharge ballasts shall be the following types required for the proposed fixture lamping: Peak Load (PL) ballasts for Metal Halide (MH) lamps. Ballasts to be independently mounted outdoors shall be waterproof. Ballasts shall conform to U.L. 1029.
- F. Poles, Brackets, Pole Bases and Attachments: Shall be rated for service with wind velocities of 100 mph considering the force exerted by the wind on the maximum exposure of the fixture luminaire selected.
- G. Poles shall be anchor base type round, height and style as indicated, finished to match luminaire, complete with handhole and gasketed cover, anchor bolts with leveling and locking screws, grounding connection, and matching base cover.
- H. Concrete pole bases shall be cast-in-place reinforced concrete as indicated with anchor bolts and conduit entries as per manufacturer. Concrete shall be rated 3,000 PSI at 28 day test.
- I. Concrete:
 - 1. Concrete for electrical requirements shall be at least 3,000 psi concrete with 1-inch maximum aggregate conforming to the requirements of Division 3 for Cast-In-Place concrete.

2.02 SOLID STATE LUMINAIRES

- A. Housing, where applicable:
 - 1. Steel bonderized or equal rust protected, or aluminum, rigid construction. Minimum gauge thickness shall be as follows:
 - a. Interior locations: No. 20-gauge steel, No. 16-gauge aluminum.
- B. Finish:
 - 1. Baked enamel finish (except when otherwise specified).
 - a. Concealed interior surfaces (this applies to interior hardware, circuit boards, etc.) matte black.
 - b. Concealed exterior surfaces: matte black.
 - c. Visible surfaces: color and texture as specified below for each luminaire type or as selected.
 - d. Exterior luminaire finish: refer to Luminaire Schedule.
- C. Light Emitting Diode (LED) requirements:
 - 1. Correlated color temperature (CCT) for phosphor-coated white LEDs must have one of the following designated CCT's and fall within the following binning standards.
 - a. 2700K defined as 2725 +/- 145K
 - b. 3000K defined as 3045 +/- 175K
 - c. 3500K defined as 3465 +/- 245K
 - d. 4000K defined as 3985 +/- 275K
 - e. 4500K defined as 4503 +/- 243K
 - f. 5000K defined as 5028 +/- 283K
 - g. 5700K defined as 5665 +/- 355K
 - h. 6500K defined as 6530 +/- 510K
 - 2. Color spatial uniformity shall be limited to variations in chromaticity for different directions (i.e. changes in viewing angle) within 0.004 from the weighted average point on the CIE 1976 (u',v') diagram.
 - 3. Color maintenance shall be limited to a maximum change in chromaticity of 0.007 on the CIE 1976 (u',v') diagram over the lifetime of the product.

- a. Color rendering index: Color rendering index to be determined using ANSI C78.377-2008 and applicable IESNA standards.
 - b. Laboratory tests must be produced using specific module(s)/array(s) and power supply combination that will be used in production.
 - c. Manufacturers must provide a test report from a laboratory accredited by NVLAP or one of its MRA signatories
4. Lumen depreciation
- a. Lumen depreciation to be measured using IESNA LM-80-08 standard for IES approved method of measuring lumen maintenance of LED light sources.
 - b. Phosphor coated white LED module(s)/array(s) shall deliver at least 70% of initial lumens for a minimum of 50,000 hours when installed in-situ and operated at 100% output and the maximum specified operating temperature.
 - c. Colored LED module(s)/array(s) shall deliver at least 50% of initial lumens for a minimum of 50,000 hours when installed in-situ and operated at 100% output and the maximum specified operating temperature.
5. Acceptable LED manufacturers:
- a. Cree
 - b. Nichia
 - c. Osram Opto Semiconductors
 - d. Philips Lumileds
 - e. Soraa
 - f. Xicato
- D. Luminaire Efficacy:
1. Luminaire efficiency shall be measured using IESNA LM-79-08 standard for electrical and photometric measurements of solid state lighting products.
 2. Manufacturer shall provide published luminaire efficacy, which is defined as luminaire light output divided by luminaire input power measured in a 25 degree Celsius environment. Efficacy shall include power supply, thermal, optical, and luminaire losses.
- E. Thermal Management:
1. Solid state luminaire shall not exceed LED manufacturer's maximum junction temperature requirements when operated in-situ at luminaire manufacturer's maximum ambient operating temperature and 100% light output.
 2. Solid state luminaires shall be thermally protected using one of more of the following thermal management techniques:
 - a. Metal core board
 - b. Gap pad
 - c. Internal monitoring firmware
 3. Solid state luminaire housing shall be designed to transfer heat from the LED board to the outside environment.
- F. Power Supply/Driver requirements:
1. Power factor of 0.90 or greater for primary application
 2. Input current shall have Total Harmonic Distortion (THD) of less than 20%.
 3. Minimum operating temperature of minus 20 degrees Celsius or below when used in luminaires intended for outdoor applications.
 4. Output operating frequency to be equal to or greater than 120 Hz.
 5. Operate with sustained input variations of +/- 10% (voltage and frequency) with no damage to the driver.
 6. Tolerate sustained open circuit and short circuit output conditions without damage and without need for external fuses or trip devices.

7. Output shall be regulated to +/- 5% across published load range.
 8. Class A sound rating.
 9. Outputs shall have current limiting protection.
 10. Operate LEDs at constant and regulated current levels. LEDs shall not be overdriven beyond the diode manufacturer's specified nominal voltage and current.
- G. Solid State Lighting Controls:
1. Control interface to dimmable power supplies shall consist of one of the following:
 - a. Line Voltage Dimming. Controls to be rated for magnetic or electronic low voltage transformer operation.
 - b. Low voltage (0-10V) control. Controls to be compatible with either current sink or current source operation.
 - c. DMX control
 2. Dimmable LED power supplies shall use pulse width modulation (PWM) to regulate power to LEDs
 - a. Dimmable power supplies shall have 12-bit or greater resolution to obtain flicker-free operation throughout the dimming range.
- H. System Installation
1. Hardwired connections to solid state luminaires shall be reverse polarity protected and provide high voltage protection in the event connections are reversed or shorted during the installation process.
 2. All solid state luminaires (100% of each lot) shall undergo a minimum eight-hour burn-in test during manufacturing. Solid state lighting installations shall be UL Listed as a low-voltage lighting system including, but not limited to, luminaire, power supply, controller, keypad, and wiring.
- I. Warranty
1. Luminaires, drivers, and controllers for solid state lighting systems shall be covered by a five-year warranty against defects in workmanship or material. Warranty shall include in-warranty service program providing for payment of authorized labor charges incurred in replacement of inoperative in-warranty equipment.

2.03 LUMINAIRE CONSTRUCTION

- A. Sheet metal: materials and thicknesses shall be 20 gauge (0.7 mm or 0.027") min., free of dents, scratches, oil-can, or other defects.
- B. Painted luminaires: exposed weld marks, joints, and seams shall be filled and sanded smooth before finishing.
- C. All edges cleaned and dressed to remove sharp edges or burrs.
- D. Extrusions: 1/10" min. wall thickness, smooth and free of tooling lines, with cast end plates that exactly match extrusion profiles.
- E. Castings: smooth, free of pits, scales, gate marks, or blemishes.
- F. Spinings shall have 1/32" min. thickness, smooth, free of spinning lines or blow-back, with clean edges.
- G. Welds: Follow recommendations of American Welding Society. All welds continuous and free of spatter, residue, or warping.
- H. No light leaks visible. Field paint exterior of housing with high temperature paint if necessary.
- I. Exposed end plates and joiners, with concealed fasteners.
- J. Hardware:
 1. Steel or aluminum exterior luminaires: stainless steel hardware.

2. Stainless steel luminaires: stainless steel hardware.
 3. Copper alloy luminaires: brass hardware.
- K. Raceways: Where used for through wiring, luminaires must be approved for use as raceways.

PART 3 - EXECUTION

3.01 INSTALLATION:

- A. Refer to Section 26 27 00, Part 2.2, for wiring and splicing requirements.
- B. Underground cable installation shall conform to National Electrical Code except as otherwise specified or indicated.
- C. Contractor Damage: The Contractor shall promptly cause repairs to be made to any indicated utility lines or systems damaged by his operation.
- D. Under roads and paved areas, ducts shall be EPC-80-PVC polyvinyl chloride conduit.
- E. Cables shall be in one piece without splices between connections except where the distance exceeds the lengths in which the cable is furnished.
- F. Bends in cables shall have an inner radius of not less than 12 times the cable diameter.
- G. Horizontal slack of approximately 3 feet shall be left in the ground on each end of cable runs, on each side of connection and at all points where connections are to be made above ground level.
- H. Earthwork: Earthwork for electrical requirements shall conform to the requirements of Division 31.
- I. Coordinate work with other trades. Pre-ship anchor bolts and templates for use in preparing bases for installation. After leveling luminaires, pack grout between mounting plate and concrete footing. Provide weep holes to prevent accumulation of moisture inside pole base.

3.02 TESTS

- A. Test under provisions of Division 1, Section 26 08 00, and Section 26 51 01.
- B. The Owner shall be notified at least three working days in advance of the Contractor's proposed date of the tests to permit scheduling, and to permit witnessing of the tests. The Contractor shall furnish the Owner with three copies of the results of the tests.
- C. Circuits: The Contractor shall test each circuit, all controllers, and components of the system for proper operation. The Contractor shall furnish the Owner with three copies of the test results.
- D. Compaction Tests: Backfill shall be tested for compaction in accordance with ASTM D1556.
- E. Operating Test: Contractor shall operate the system in the presence of the Owner proving the proper operation.

END OF SECTION

SECTION 26 5700
LOW VOLTAGE LIGHTING CONTROL SYSTEM

PART 1 - GENERAL

1.01 SYSTEM DESCRIPTION

- A. Furnish all labor, materials, apparatus, tools, equipment transportation, temporary construction and commissioning services as indicated on the Drawings or described in these Specifications and as required to make a complete working facility lighting control system.
- B. Integrated Low Voltage Lighting Control System:
 - 1. The low voltage lighting control system shall consist of relay panels, digital device Segment Manager and LMCS system configuration software.
 - 2. The system shall accept program changes from the LMCS system configuration software for date and time, location, holidays, event scheduling, button binding and group programming.
- C. Requirements are indicated in Section 26 27 00 for raceways and electrical boxes and fittings required for installation of control equipment and wiring.
- D. Provide CBC 2016 compliant seismic installation. See Section 26 05 00 for all certification and submittal requirements.

1.02 INCORPORATED DOCUMENTS

- A. Sections 26 05 00, 26 27 00, 26 51 01 and 26 56 01 apply to all Work in this Section.
- B. Drawings and general provisions of the Contract, including General and Supplementary Conditions and other Division 1 Specification Sections, apply to this Section.

1.03 QUALITY ASSURANCE

- A. Manufacturers: Firms regularly engaged in manufacture of lighting control equipment and ancillary equipment, of types and capacities required, whose products have been in satisfactory use in similar service for not less than 5 years.
- B. Installer Qualifications: Installer shall be one who is experienced in performing the Work of this Section, and who has specialized in installation of Work similar to that required for this project.
- C. Component Pre-testing: All components and assemblies are to be factory pre-tested prior to installation.
- D. System Support: Factory applications engineers shall be available for telephone support.
- E. NEC Compliance: Comply with NEC as applicable to electrical wiring Work.
- F. NEMA Compliance: Comply with applicable portions of NEMA standards pertaining to types of electrical equipment and enclosures.
- G. UL Approvals: Remote panels are to be UL listed under UL 916 Energy Management Equipment.
- H. CSA Approvals: Remote panels are to be CSA listed.
- I. FCC Emissions: All assemblies are to be in compliance with FCC emissions Standards specified in Part 15 Subpart J for Class A application.
- J. All System components shall be California Title 24 compliant, where applicable.

1.04 SUBMITTALS

- A. Submit under provisions of Division 1 and 26 05 00.
 - 1. Bill of Materials: Complete list of all parts needed to fully install selected System components.

2. Shop Drawings: Submit dimensional Drawings of all lighting control system components and accessories.
3. One Line Diagram: Submit a one-line diagram of the system configuration.
4. Typical Wiring Diagrams: Submit typical wiring diagrams for all components including, but not limited to, relay panels, relays, digital low voltage switches, digital occupancy sensors and digital daylighting controls.

1.05 MANUFACTURERS

- A. Integrated Low Voltage Lighting Control System:
 1. The basis of the specified system is the Watt Stopper Digital Lighting Management (DLM) or an equal. Any other system to be considered must submit descriptive information 10 days prior to bid.
- B. Prior approval does not guarantee final approval by the electrical engineer. The contractor shall be completely responsible for providing a system meeting this specification in its entirety. All deviations from this specification must be listed and individually signed off by the engineer.
- C. The Owner reserves the right to reject a proposed substitution based on his agent's professional judgment as to the utility, visual appropriateness, or finish of substitutions.

1.06 DELIVERY, STORAGE, AND HANDLING

- A. Delivery: Deliver materials in Manufacturer's original, unopened, undamaged packages with intact identification labels.
- B. Storage and Protection: Store materials away from exposure to harmful weather conditions and at temperature and humidity conditions recommended by Manufacturer.

1.07 GUARANTEE AND WARRANTIES

- A. All Work performed under this Section must be guaranteed to be free of defects in products or workmanship for one year after date of acceptance by Owner, unless noted otherwise in General Conditions.

PART 2 - PRODUCTS

2.01 DIGITAL LIGHTING MANAGEMENT DLM

- A. Description
 1. Lighting Control System shall include Dimming / Switching Room Controllers, Digital Occupancy Sensors, Digital Daylight Sensors, Digital Dimmers / Switches, Network Components and Relay Panels. All project components shall be UL listed and consist of the following:
 2. Lighting Control Panel Enclosure Tub: NEMA 1, NEMA 3R, or NEMA 4 as indicated on the drawings, sized to accept an interior with 1-8 relays, 1-24 relays and six (6) four pole contactors, or 1-48 relays with six (6) four pole contactors.
 3. Cover: Surface or Flush as required, hinged and lockable and with restricted access to line voltage section. A final typed wiring schedule directory card shall be affixed to the cover's back.
 4. Interior: Barrier included for separation of high voltage (class 1) and low voltage (class 2) wiring. The interior shall include intelligence boards, power supply, mechanically latched control relays and multi-pole contactors. The interiors shall include the following features:
 - a. Screwless, removable, plug-in connections for all low voltage terminations.
 - b. Digital inputs (four RJ-45 jacks) shall support 1-, 2-, 3-, 4-, and 8-button digital switches, digital occupancy sensors and digital daylight sensors.

- c. Each relay shall be capable of individual ON/OFF control by a low voltage switch and / or occupancy sensor input.
- d. The system shall monitor true relay status; the relay status shall be displayed at the onboard pilot LED and monitored by the system electronics.
- e. Stagger the On and OFF sequence of the relays.
- f. Heavy Duty Relays - Mechanically latching contacts with single moving part design for improved reliability. Relays to have the following characteristics:
- g. 30 amp NEMA 410 electronic ballast rated and 20 amp tungsten, rated for 50,000 ON/OFF cycles at full load. Support #12-#14 AWG solid or stranded wire and rated for 120 and 277 volts; 20 amp NEMA 410 electronic ballast rated and 20 amp tungsten 347 volts.
 - 1) 30 VAC isolated contacts for status feedback and pilot light indication.
 - 2) 14,000 amp short circuit current rating.
 - 3) Contactors shall be DIN rail mounted, four pole standard, normally open or normally closed, electrically held with 120 or 277 volt coil voltage to match panel control power voltage. Contractors shall be compatible with all lighting, ballast and HID loads and be rated for 277 volt 20 amp tungsten and 600 volt 30 amp ballast loads.
5. Power Supply: Multi-voltage transformer assembly with enough power to supply all electronics, occupancy sensors, dataline switches, pilot lights, and photocells as necessary to meet the project requirements. Power supply to have internal over-current protection with automatic reset and metal oxide varistor protection.
6. Multiple panels shall be able to be networked together for global control. The LMCP panels shall be networked together over a MS/TP 3-conductor connection.

2.02 GROUP, CHANNEL, SCHEDULE AND PATTERN CONTROL

A. Description

1. The lighting control panel shall support schedule, group, and photocell control functions via the network as configured using the LMCS Configuration Software.
2. Group Status: Each group pushbutton shall include an LED status indication. The LED shall be ON whenever all of the relays within the group are ON; and shall go OFF when all of the relays within the group go OFF. The LED will be green when in a "mixed" state. Each channel shall also have an associated dry contact closure and pilot contact which tracks the LED operation described above.

B. Features

1. Individual relays shall be able to be assigned to more than one channel, and the channel status shall be annunciated appropriately.
2. Each channel shall also have an input for connecting switch or dry contacts for controlling a channel. Inputs shall accept 2 or 3-wire maintained or momentary inputs, and groups shall be controllable by: an on-board group pushbutton switch, low voltage switch, digital switch, digital occupancy sensor, digital photocell, or time of day.
3. Screwless, removable, plug-in terminals will be provided for all low voltage wiring connections.

2.03 NETWORK CLOCK

A. Description

1. Provide an eight channel integral network clock that connects to the system using the digital MS/TP three conductor data communications wire network described in Section 2.10.

2. The clock shall be used to schedule any of the eight global channel groups (Section 2.03) in the relay panel network. The clock shall support all of the energy saving features required of ASHRAE 90.1 - 2001, IECC 2003, as well as all state and local energy codes.
 3. The clock shall provide astronomic capabilities, time delays, blink warning, daylight savings, and holiday functions and shall include a battery back-up for the clock function and EEPROM for program retention. Clocks that require multiple events to meet local Code lighting shut off requirements shall not be allowed.
 4. The clock shall allow unique scenario and time delays. Scenarios shall include:
 - a. Scheduled ON / OFF
 - b. Manual ON / Scheduled OFF
 - c. Manual ON / Auto Sweep OFF (for AS-100 Switches)
 - d. Astro ON / OFF (or Photo ON / OFF)
 - e. Astro and Schedule ON / OFF (for Photo and Schedule ON / OFF)
- B. Features
1. Runs event-based schedule routines independently (does not require BAS or Segment Manager).
 2. Supports astronomical, time-based event types
 3. Retains memory and time for a minimum of 10 years.

2.04 DIGITAL SWITCHES

- A. Description
1. Intelligent digital switching shall operate on the DLM Category 5e local network. Switches shall be available in single, dual, quad, or octal (1-button, 2-button, 4-button, or 8-button) designs. All devices shall mount in a standard single-gang box
 2. Each button in a switch shall be able to be individually programmed. Programming shall be done by the LMCT-100 handheld configuration tool. Each button shall control any one of the following options:
 - a. Any individual relay in any single panel.
 - b. Any group of relays in any single panel.
 - c. Any group of relays in the system.
- B. Features
1. Switches shall be constructed of non-breakable Lexan on all exposed parts and shall include a matching screwless Lexan wall plate.
 2. Individual buttons shall be custom engraved with a maximum of 15 characters (including spaces) on two lines, where shown on plans.
 3. Multiple digital switches wired to control the same relay or relay group shall indicate the same status automatically.
 4. Each switch shall also include a locator light illuminating the switch for easy location in the dark.
 5. Switches can be configured to follow a "Cleaning" scenario. This specific scenario shall prevent the cleaners from overriding OFF any relays turned ON by the occupant.

2.05 DIGITAL OCCUPANCY SENSORS

- A. Description
1. Digital Occupancy Sensors - Self-configuring, digitally addressable and calibrated occupancy sensors with LCD display and two-way active infrared (IR) communications.

2.06 DIGITAL PHOTOSENSORS

- A. Description

1. Digital Photosensors - Single-zone closed loop, multi-zone open loop and dual-loop daylighting sensors with two-way active infrared (IR) communications shall provide switching, bi-level, tri-level or dimming control for daylight harvesting.

2.07 DIGITAL DIMMING / SWITCHING ROOM CONTROLLERS

A. Description

1. Digital controllers for lighting and plug loads shall automatically bind the room loads to the connected devices in the space without commissioning or the use of any tools. Room and plug load controllers shall be provided to match the room lighting and plug load control requirements. The controllers shall be simple to install, and shall not have dip switches or potentiometers, or require special configuration for standard Plug n' Go applications. The control units shall include the following features.
2. Automatic room configuration to the most energy-efficient sequence of operation based upon the devices in the room.
3. Simple replacement - Using the default automatic configuration capabilities, a room controller may be replaced with an off-the-shelf.
4. Multiple room controllers connected together in a local network must automatically prioritize each room controller, without requiring any configuration or setup, so that loads are sequentially assigned using room controller device ID's from highest to lowest.
5. Device Status LEDs to indicate:
 - a. Data transmission
 - b. Device has power
 - c. Status for each load
 - d. Configuration status
6. Quick installation features including:
 - a. Standard junction box mounting
 - b. Quick low voltage connections using standard RJ-45 patch cable
7. Based on individual configuration, each load shall be capable of the following behavior on power up following the loss of normal power:
 - a. Turn on to 100%
 - b. Remain off
 - c. Turn on to last level
8. Each load shall be configurable to operate in the following sequences based on occupancy:
 - a. Auto-on/Auto-off (Follow on and off)
 - b. Manual-on/Auto-off (Follow off only)
9. The polarity of each load output shall be reversible, via digital configuration, so that on is off and off is on.
10. BACnet object information shall be available for the following objects:
 - a. Load status
 - b. Electrical current
 - c. Total watts per controller
 - d. Schedule state - normal or after-hours
 - e. Demand response control and cap level
 - f. Room occupancy status
 - g. Total room lighting and plug loads watts
 - h. Total room watts/sq ft
 - i. Force on/off all loads
11. UL 2043 plenum rated
12. Manual override and LED indication for each load

13. Dual voltage (120/277 VAC, 60 Hz). 120/277 volt models rated for 20A total load, derating to 16A required for some dimmed loads (forward phase dimming); plug load controllers shall carry application-specific UL 20 rating for receptacle control.
 14. Zero cross circuitry for each load
 15. All digital parameter data programmed into an individual room controller or plug load controller shall be retained in non-volatile FLASH memory within the controller itself. Memory shall have an expected life of no less than 10 years.
- B. On/Off Room Controllers shall include:
1. One or two relay configuration
 2. Efficient 150 mA switching power supply
 3. Three RJ-45 DLM local network ports with integral strain relief and dust cover
 4. WattStopper product numbers: LMRC-101, LMRC-102
- C. On/Off/Dimming enhanced Room Controllers shall include:
1. Real time current monitoring
 2. Multiple relay configurations
 - a. One, two or three relays (LMRC-21x series)
 - b. One or two relays (LMRC-22x series)
 3. Efficient 250 mA switching power supply
 4. Four RJ-45 DLM local network ports with integral strain relief and dust cover
 5. One dimming output per relay
 - a. 0-10V Dimming - Where indicated, one 0-10 volt analog output per relay for control of compatible ballasts and LED drivers. The 0-10 volt output shall automatically open upon loss of power to the Room Controller to assure full light output from the controlled lighting. (LMRC-21x series)
 - b. Line Voltage, Forward Phase Dimming - Where indicated, one forward phase control line voltage dimming output per relay for control of compatible two-wire or three-wire ballasts, LED drivers, MLV, forward phase compatible ELV, neon/cold cathode and incandescent loads. (LMRC-22x series)
 - c. Each dimming output channel shall have an independently configurable minimum and maximum calibration trim level to set the dimming range to match the true dynamic range of the connected ballast or driver.
 - d. The LED level indicators on bound dimming switches shall utilize this new maximum and minimum trim.
 - e. Each dimming output channel shall have an independently configurable minimum and maximum trim level to set the dynamic range of the output within the new 0-100% dimming range defined by the minimum and maximum calibration trim.
 - f. Calibration and trim levels must be set per output channel.
 - g. Devices that set calibration or trim levels per controller are not acceptable.
 - h. All configuration shall be digital. Devices that set calibration or trim levels per output channel via trim pots or dip-switches are not acceptable.
 6. Each load shall have an independently configurable preset on level for Normal Hours and After Hours events to allow different dimmed levels to be established at the start of both Normal Hours and After Hours events.
 7. Fade rates for dimming loads shall be specific to bound switch buttons, and the load shall maintain a default value for any bound buttons that do not specify a unique value.
 8. The following dimming attributes may be changed or selected using a wireless configuration tool:
 - a. Establish preset level for each load from 0-100%
 - b. Set high and low trim for each load
 - c. Set lamp burn in time for each load up to 100 hours

9. Override button for each load shall provide the following functions:
 - a. Press and release for on/off control
 - b. Press and hold for dimming control
10. WattStopper product numbers: LMRC-211, LMRC-212, LMRC-213, LMRC-221, LMRC-222

D. Plug Load Room Controllers shall include:

1. One relay configuration with additional connection for unswitched load
2. Configurable additive time delay to extend plug load time delay beyond occupancy sensor time delay (e.g. a 10 minute additive delay in a space with a 20 minute occupancy sensor delay shall ensure that plug loads turn off 30 minutes after the space is vacated).
3. Factory default operation shall be Auto-on/ Auto-off, based on occupancy
4. Real time current monitoring of both switched and un-switched load (LMPL-201 only)
5. Efficient switching power supply
 - a. 150mA (LMPL-101)
 - b. 250mA (LMPL-201)
6. RJ-45 DLM local network ports
 - a. Three RJ-45 ports (LMPL-101)
 - b. Four RJ-45 ports (LMPL-201)
7. WattStopper product numbers: LMPL-101, LMPL-201.

2.08 DLM SEGMENT NETWORK (ROOM TO ROOM NETWORK).

- A. The segment network shall be a linear topology, BACnet-based MS/TP subnet to connect DLM local networks (rooms) and LMCP relay panels for centralized control.
 1. Each connected DLM local network shall include a single network bridge (LMBC-300), and the network bridge shall be the only room-based device that is connected to the segment network.
 2. Network bridges, relay panels and segment managers shall include terminal blocks, with provisions for separate "in" and "out" terminations, for segment network connections.
 3. The segment network shall utilize twisted pair, shielded, cable as specified by the lighting control manufacturer. The maximum cable run for each segment shall be 4,000 feet. Conductor-to-conductor capacitance of the twisted pair shall be less than 30 pf/ft and have a characteristic impedance of 120 Ohms.
 4. Network signal integrity will require that each conductor and ground wire be correctly terminated at every connected device.
 5. Substitution of manufacturer-specified cable must be pre-approved: Manufacturer may not certify network reliability and may void warranty, if non-approved cable is installed, and if terminations are not completed according to manufacturer's specific requirements.
 6. Segment networks shall be capable of connecting to BACnet-compliant BAS (provided by others) either directly, via MS/TP, or through NB-ROUTERS, via BACnet/IP or BACnet/Ethernet. Systems whose room-connected network infrastructure require gateway devices to provide BACnet data to a BAS are unacceptable.
- B. WattStopper Product Number: LM-MSTP, LM-MSTP-DB

2.09 CONFIGURATION TOOLS

- A. A wireless configuration tool shall facilitate optional customization of DLM local networks using two-way infrared communications, while PC software shall connect to each local network via a USB interface.
- B. Features and functionality of the wireless configuration tool shall include but not be limited to:
 1. Two-way infrared (IR) communication with DLM IR-enabled devices within a range of approximately 30 feet.

2. High visibility organic LED (OLED) display, pushbutton user interface and menu-driven operation.
3. Ability to read and modify parameters for room controllers, occupancy sensors, wall switches, daylighting sensors, network bridges and relay panels, and identify room devices by type and serial number.
4. Ability to save up to eight occupancy sensor setting profiles, and apply profiles to selected sensors.
5. Temporarily adjust light level of any load(s) on the local network, and incorporate those levels in scene setting. Set room mode for testing of Normal Hours (NH) and After Hours (AH) parameter settings.
6. Adjust or fine-tune daylighting settings established during auto-configuration, and input light level data to complete configuration of open loop daylighting controls.
7. Set room mode for testing of Normal Hours (NH) and After Hours (AH) parameter settings.
8. Verify status of building level network devices.

C. WattStopper Product Numbers: LMCT-100, LMCI-100/LMCS-100

2.10 NETWORK BRIDGE

- A. The network bridge module shall connect a DLM local network to a BACnet-compliant segment network for communication between rooms, relay panels and a segment manager or BAS. Each local network shall include a network bridge component to provide a connection to the local network room devices. The network bridge shall use industry standard BACnet MS/TP network communication and an optically isolated EIA/TIA RS-485 transceiver.
1. The network bridge shall be provided as a separate module connected on the local network through an available RJ-45 port.
 2. Provide Plug n' Go operation to automatically discover room devices connected to the local network and make all device parameters visible to the segment manager via the segment network. No commissioning shall be required for set up of the network bridge on the local network.
 3. The network bridge shall automatically create standard BACnet objects for selected room device parameters to allow any BACnet-compliant BAS to include lighting control and power monitoring features as provided by the DLM room devices on each local network. BACnet objects shall be created for the addition or replacement of any given in-room DLM device for the installed life of the system. Products requiring that an application-specific point database be loaded to create or map BACnet objects are not acceptable. Systems not capable of providing BACnet data for control devices via a dedicated BACnet Device ID and physical MS/TP termination per room are not acceptable. Standard BACnet objects shall be provided as follows:
 - a. Read/write the normal or after hours schedule state for the room
 - b. Read the detection state of each occupancy sensor
 - c. Read the aggregate occupancy state of the room
 - d. Read/write the On/Off state of loads
 - e. Read/write the dimmed light level of loads
 - f. Read the button states of switches
 - g. Read total current in amps, and total power in watts through the room controller
 - h. Read/write occupancy sensor time delay, PIR sensitivity and ultrasonic sensitivity settings
 - i. Activate a preset scene for the room
 - j. Read/write daylight sensor fade time and day and night setpoints
 - k. Read the current light level, in foot-candles, from interior and exterior photosensors and photocells

- l. Set daylight sensor operating mode
- m. Read/write wall switch lock status
- n. Read watts per square foot for the entire controlled room
- o. Write maximum light level per load for demand response mode
- p. Read/write activation of demand response mode for the room
- q. Activate/restore demand response mode for the room

B. WattStopper product numbers: LMBC-300

2.11 SEGMENT MANAGER

- A. For networked applications, the Digital Lighting Management system shall include at least one segment manager to manage network communication. It shall be capable of serving up a graphical user interface via a standard web browser utilizing either unencrypted TCP/IP traffic via a configurable port (default 80) or 256 bit AES encrypted SSL TCP/IP traffic via a configurable port (default 443).
- B. Each segment manager shall have integral support for at least three segment networks. Segment networks may alternately be connected to the segment manager via external routers and switches, using standard Ethernet structured wiring. Each router shall accommodate one segment network. Provide the quantity of routers and switches as shown on the plans.
- C. Operational features of the Segment Manager shall include the following:
 1. Connection to PC or LAN via standard Ethernet TCP/IP with the option to use SSL encrypted connections for all traffic.
 2. Easy to learn and use graphical user interface, compatible with latest version of Internet Explorer, or equal browser. Shall not require installation of any lighting control software to an end-user PC.
 3. Log in security capable of restricting some users to view-only or other limited operations.
 4. Automatic discovery of DLM devices and relay panels on the segment network(s). Commissioning beyond activation of the discovery function shall not be required to provide communication, monitoring or control of all local networks and lighting control panels.
 5. After discovery, all rooms and panels shall be presented in a standard navigation tree format. Selecting a device from the tree shall allow the device settings and operational parameters to be viewed and changed by the user.
 6. Ability to view and modify room device operational parameters. It shall be possible to set device parameters independently for normal hours and after hours operation including sensor time delays and sensitivities, and load response to sensor including Manual-On or Auto-On.
 7. Ability to set up schedules for rooms and panels, view and override current status of panel channels and relays, and assign relays to groups. Schedules shall automatically set controlled zones or areas to either a normal hours or after hours mode of operation. Support for a minimum of 100 unique schedules, each with up to four time events per day. Support for annual schedules, holiday schedules and unique date-bound schedules.
 8. Ability to group rooms and loads for common control by schedules, switches or network commands.
 9. Ability to monitor connected load current and display power consumption for areas equipped with room controllers incorporating the integral current monitoring feature.
 10. Provide capabilities for integration with a BAS via BACnet protocol. At a minimum, the following points shall be available to the BAS via BACnet IP connection to the segment manager: room occupancy state; room schedule mode; room switch lock control; individual occupancy sensor state; room lighting power; room plug-load power; load

ON/OFF state; load dimming level; panel channel schedule state; panel relay state; and Segment Manager Group schedule state control.

11. The Segment Manager shall allow access and control of the overall system database via Native Niagara AX FOX connectivity. Systems that must utilize a Tridium Niagara controller in addition to the programming, scheduling and configuration server are not acceptable.
- D. Segment Manager shall support multiple DLM rooms as follows:
 1. Support up to 120 network bridges and 900 digital in-room devices (LMSM-3E).
 2. Support up to 300 network bridges and 2,200 digital in room devices, connected via network routers and switches (LMSM-6E).
- E. WattStopper Product Numbers: LMSM-3E, LMSM-6E, NB-ROUTER, NB-SWITCH, NB-SWITCH-8, NB-SWITCH-16.

2.12 PROGRAMMING, CONFIGURATION AND DOCUMENTATION SOFTWARE

- A. PC-native application for optional programming of detailed technician-level parameter information for all DLM products, including all parameters not accessible via BACnet and the handled IR configuration tool. Software must be capable of accessing room-level parameter information locally within the room when connected via the optional LMCI-100 USB programming adapter, or globally for many segment networks simultaneously utilizing standard BACnet/IP communication.
- B. Additional parameters exposed through this method shall include but not be limited to:
 1. Occupancy sensor detection LED disable for performance and other aesthetic spaces where blinking LEDs present a distraction.
 2. Six occupancy sensor action behaviors for each controlled load, separately configurable for normal hours and after hours modes. Modes include: No Action, Follow Off Only, Follow On Only, Follow On and Off, Follow On Only with Override Time Delay, Follow Off Only with Blink Warn Grace Time, Follow On and Off with Blink Warn Grace Time.
 3. Separate fade time adjustments per load for both normal and after hours from 0 - 4 hours.
 4. Configurable occupancy sensor re-trigger grace period from 0 - 4 minutes separate for both normal hours and after hours.
 5. Separate normal hours and after hours per-load button mode with modes including: Do nothing, on only, off only, on and off.
 6. Load control polarity reversal so that on events turn loads off and vice versa.
 7. Per-load DR (demand response) shed level in units of percent.
 8. Load output pulse mode in increments of 1 second.
 9. Fade trip point for each load for normal hours and after hours that establishes the dimmer command level at which a switched load closes its relay to allow for staggered On of switched loads in response to a dimmer.
- C. Generation of reports at the whole file, partial file, or room level. Reports shall include but not be limited to:
 1. Device list report: All devices in a project listed by type.
 2. Load binding report: All load controller bindings showing interaction with sensors, switches, and daylighting.
 3. BACnet points report: Per room Device ID report of the valid BACnet points for a given site's BOM.
 4. Room summary report: Device manifest for each room, aggregated by common BOM, showing basic sequence of operations.
 5. Device parameter report: Per-room lists of all configured parameters accessible via hand held IR programmer for use with O&M documentation.

6. Scene report: All project scene pattern values not left at defaults (i.e. 1 = all loads 100%, 2 = all loads 75%, 3 = all loads 50%, 4 = all loads 25%, 5-16 = same as scene 1).
 7. Occupancy sensor report: Basic settings including time delay and sensitivity(ies) for all occupancy sensors.
- D. Network-wide programming of parameter data in a spreadsheet-like programming environment including but not limited to the following operations:
1. Set, copy/paste an entire project site of sensor time delays.
 2. Set, copy/paste an entire project site of sensor sensitivity settings.
 3. Search based on room name and text labels.
 4. Filter by product type (i.e. LMRC-212) to allow parameter set by product.
 5. Filter by parameter value to search for product with specific configurations.
- E. Network-wide firmware upgrading remotely via the BACnet/IP network.
1. Mass firmware update of entire rooms.
 2. Mass firmware update of specifically selected rooms or areas.
 3. Mass firmware upgrade of specific products.
- F. WattStopper Product Number: LMCS-100, LMCI-100

PART 3 - EXECUTION

3.01 INSTALLATION

- A. Integrated Low Voltage Lighting Control System:
1. Digital Switches and/or photocells shall be mounted in the spaces as indicated on the Drawings. Each low voltage wire shall be labeled clearly indicating which relay panel it connects to. Use only Watt Stopper pre-terminated LMRJ series Cat 5e cable as indicated on the Drawings. All relays and switches shall be tested after installation to confirm proper operation and the loads recorded on the directory card in each panel.
 2. The relay panels shall be mounted in electrical closets as indicated on the Drawings. The numbered relays in the panel shall be wired to control the power to each load as indicated on the Panel Wiring Schedules included in the Drawings. All power wiring shall be identified with the circuit breaker number controlling the load. If multiple circuit breaker panels are feeding into a relay panel, wires shall clearly indicate the originating panel's designation.

3.02 PRE-INSTALLATION MEETING

- A. Manufacturer shall provide a factory authorized representative to provide a functional overview of the lighting control system prior to products being installed.
1. Discuss functionality and integration of all products per design requirements.
 2. Confirm location of occupancy sensors and photocells as required.
 3. Confirm low voltage control wires meet specification.
 4. Explain adjustment options and verify specification requirements for each device.

3.03 PROGRAMMING

- A. Set / program lighting controls per relay schedules on drawings, with input from Owner for exact times required for each operation.
- B. All programming shall comply with Title 24 requirements (i.e. automatic control and override limits).
- C. For relays controlling halogen and metal halide lamps, a minimum 15 minute off period is required per day to mitigate potential for non-passive end of life failure. Review programming schedules and program this off-cycle for relays otherwise scheduled for continuous operation. Coordinate timing of off-cycle with Owner.
- D. Test all programming for proper operation of each relay at scheduled times.

3.04 SYSTEM STARTUP

- A. The Manufacturer shall provide a factory authorized technician to commission and confirm proper installation and operation of all system components.
- B. Contractor shall provide system documentation after the equipment has been installed:
 - 1. Lighting control operational summary sheet.
 - 2. Programming record sheet.
 - 3. System Installation and Operation Manual shall be provided to the owner.

3.05 TRAINING

- A. Manufacturer shall provide factory authorized application engineer to train Owner personnel in the operation and programming of the lighting control system for the first (2) two days of occupancy; then (1) one week later, and again (1) month later.

3.06 TESTS

- A. Test under provisions of Section 26 05 00 and 26 08 00.
- B. The Owner shall be notified at least three working days in advance of the Contractor's proposed date of the tests to permit scheduling, and to permit witnessing of the tests. The Contractor shall furnish the Owner with three copies of the results of the tests.
- C. Circuits: The Contractor shall test each circuit, all controllers, and components of the system for proper operation. The Contractor shall furnish the Owner with three copies of the test results.
- D. Operating Test: Contractor shall operate the system in the presence of the Owner proving the proper operation of the system and all components.

END OF SECTION

SECTION 27 0000
TELECOMMUNICATIONS SYSTEM

PART 1 - GENERAL

1.01 DESCRIPTION

- A. This project includes the provisions for and installation of a complete telecommunications system pathways and wiring infrastructure system for the stadium facility, including all terminations, testing, and all related passive components required for operation.

1.02 WORK INCLUDED

- A. Work included in this Section: All materials, labor, equipment, services, and incidentals necessary to install the work as shown on the drawings and as specified hereinafter, including, but not limited to the work listed below.
- B. Provide and install a complete and functional data communication system, including voice services via VoIP capability, and all necessary passive components, to allow full operation of the wiring infrastructure system upon completion.
- C. The installation shall include all optical fiber, twisted pair copper, inner-duct, conduit, fiber interconnect / patching equipment, copper interconnect / patching equipment, fiber connectors, copper connectors, splices, fiber patch cords / jumpers, copper patch cords / jumpers, wiring blocks, data outlets, wi-fi access points, and any other equipment specified herein.
- D. The installation shall not include any active network components such as routers, switches, hubs, fiber optic transceivers, wireless communications system transceivers, antennae, base stations and concentrators or servers, which shall be supplied by the owner.
- E. Upon completion of the installation, this contractor shall test all fiber and copper pathways and record the test results as specified herein. Test results must be delivered to the owner upon completion of project
- F. The scope of work under this Section shall include any other work as might reasonably be implied as required, even though not specifically mentioned herein or shown on the drawings.
- G. Provide CBC 2016 compliant seismic installation. See Section 26 05 00 for all certification and submittal requirements.

1.03 RELATED WORK

- A. Division 1 - General Requirements.
- B. Division 9 - Finishes.
- C. Section 26 05 00 - Basic Electrical Requirements
- D. Section 26 27 00 - Basic Electrical Materials & Methods
- E. Equipment and work provided by the owner's network integrator, including owner provided network servers, switches, hubs, optical fiber transceivers, routers, wireless communication system equipment, etc.

1.04 INCORPORATED DOCUMENTS

- A. Requirements of the General Conditions, supplementary conditions, and Division 1 Sections apply to the work of this section, unless modified herein.
- B. Published specifications, standard tests or recommended methods of trade, industry or government organizations shall apply to work of this section where cited by abbreviations noted below, unless modified herein.
 - 1. National Electrical Code, latest edition, (NEC), Article 800

2. ANSI/TIA-492.AAAC-B - Detail Specification for 850-nm Laser-Optimized, 50-um Core Diameter/125-um Cladding Diameter Class 1a Graded-Index Multimode Optical Fibers
3. ANSI/TIA-492.AAAD - Detail Specification for 850-nm Laser- Optimized, 50-um Core Diameter/125-um Cladding Diameter Class 1a Graded-Index Multimode Optical Fibers Suitable for Manufacturing OM4 Cabled Optical Fiber
4. ANSI/TIA-492.CAAB - Detail Specification for Class IVa Dispersion-Unshifted Single-Mode Optical Fibers with Low Water Peak; Current Edition
5. ANSI/TIA-568.0-D - Generic Communications Cabling for Customer Premises
6. Underwriters' Laboratories, Inc. (UL), UL 1459, UL 1863.
7. ANSI/TIA-568.1-D "Commercial Building Communications Cabling Standard"
8. ANSI/TIA-568.3-D "Optical Fiber Cabling and Components Standard"
9. ANSI/TIA-569-D "Telecommunications Pathways and Spaces"
10. ANSI/TIA-568-C.2-1. "Balanced Twisted-Pair Telecommunications Cabling and Components Standard"
11. ANSI/TIA-606-B.1 - Administration Standard for the Commercial Telecommunications Infrastructure
12. ANSI/TIA-607-C - Generic Telecommunications Bonding and Grounding (Earthing) for Customer Premises
13. ANSI/TIA-862-B - Structured Cabling Infrastructure Standard for Intelligent Building Systems
14. ANSI/TIA-942-A - Telecommunications Infrastructure Standard for Data Centers
15. BICSI - TDMM, Building Industries Consulting Services International, Telecommunications Distribution Methods Manual (TDMM)
16. IEEE 802.3 "Carrier Sense Multiple Access With Collision Detection".
17. IEEE 802.11b "Wireless Network standard"
18. Owner's telecommunications Standards and Requirements.

1.05 CONTRACTOR QUALIFICATIONS

- A. Contractor must possess a valid state Contractor's License and must have successfully performed at least three projects of similar scope, within two years of the date of this bid. Proof of performance shall be in the form of reference sheets, which shall include a brief description of the project, the beginning and ending contract price, the project foreman or superintendent's name, and the name, address, and telephone number of a project contact.
- B. Contractor must be able to prove to the satisfaction of Owner that it has significant experience in the installation of optical fiber cable systems. Installation must include installation of optical fiber cable, fiber termination, knowledge of interconnect equipment, and a thorough knowledge of testing procedures. Contractor must provide a minimum of three references supporting its claim of experience for similar projects within the two years prior to this bid. Documentation must be included with the bid documents submitted.
- C. Contractor must have been in business and in the business of installing telecommunications systems, continuously, for a period of at least three years, prior to the date of this bid.

1.06 SUBMITTALS

- A. General: Comply with the requirements of Section 26 05 00 - Submittals.
- B. Submit complete list of all items of materials to be furnished, and installed to the owner for compliance review prior to purchasing the materials. Submittals shall include:
 1. Complete bill of materials and equipment, including a complete listing of the characteristics of the equipment as specified.
 2. One line diagram indicating all system connections, all closet locations, rack arrangements, cabinets, and workstation outlets.

3. Rack and communications cabinet layouts and dimensions.
 4. Samples of proposed cable markers and labeling, and patch panel labeling and color-coding.
 5. List of instrumentation to be used for system testing, including certificate of manufacturer's calibration.
 6. ¼ scale plan of all telecommunications rooms and closets, indicating proposed layout of all equipment and cable trays, troughs, and runways.
 7. Manufacturer's warranty application for the indicated project.
 8. Schedule of work completion coordinated with the General Contractor.
- C. Submit Contractor's qualifications as outlined in Section 1.5 above.
- D. Submit "as-built" record drawings at the completion of the installation and testing.
- E. The Contractor shall submit all testing documentation prior to acceptance of the work by the Owner.
- F. Contractor shall submit to the Owner, in writing, 48 hours advance notice when testing of optical fiber cable will begin.

1.07 GENERAL REQUIREMENTS

- A. The telecom communications system shall consist of three components:
1. An optical fiber backbone.
 2. Twisted pair copper voice and data cabling.
 3. Twisted pair copper cabling for wireless access points.
- B. Each building shall be connected via a single multi-strand single mode optical fiber cable (or composite single mode/multimode cable where indicated on the drawing(s) to the nearest campus IDF. New Individual Intermediate Distribution Frames (IDF) shall be located as indicated on the Drawings for additional termination/patching of horizontal copper station cabling. Each optical fiber cable shall originate at the campus IDF and shall be terminated at its respective new IDF at the stadium area.
- C. All optical fiber cables shall be enclosed in innerduct installed in conduit.
- D. All copper backbone cables shall be routed along with the fiber cable.
- E. From each IDF, one or more twisted-pair copper cables shall be routed to each data outlet location, and to each wireless antenna location, as indicated on the drawings.
1. The wiring system shall be provided and installed per TIA / EIA-568 wiring topology and shall be Category 6A rated.
 2. Unshielded twisted pair (UTP) cable, installed for high-speed data application, shall not exceed 295 feet in length between terminations.
- F. Terminations:
1. All fiber strands shall be terminated with connectors and land on fiber interconnect equipment.
 2. All data cables and wireless communications cables shall be terminated on modular patch panels.
 3. All voice cables shall be terminated on modular patch panels, or on wiring blocks where indicated on the drawings.
 4. All active equipment will be provided and installed by the owner.
- G. The IDF's will also house active data distribution equipment provided by the owner, possibly including but not limited to local area network hubs and switches, optical fiber transceivers, wireless communication systems base stations and concentrations routers, and servers. This Contractor shall coordinate with Owner's network integrator to ensure that data rack and cabinet layouts fully accommodate all owner-provided equipment.

1.08 FUNCTION AND OPERATION

- A. The function of the data communications cable system is to transmit data signals from a central location to multiple individual data outlet locations. Upon completion of the work outlined in this specification, the entire cable system, including cable, and communications outlets shall be tested to (and meet) Category 6A compliance.
 - 1. Horizontal UTP Category 6A 23AWG copper cabling system shall be guaranteed to exceed all TIA-568-C.2 link and channel performance requirements and be capable of supporting 10G Base-T (802.3an) and ISO/IEC 11801 Class EA applications for a total distance of 100 meters with equipment cords. System shall be guaranteed to meet all Cat 6A requirements for short links and channels down to a 10 foot link (5 meter channel) with a guaranteed 4 dB margin of Alien Crosstalk.
 - 2. Upon completion of the work, the multimode optical fiber cable system (if multimode is used on this project) shall be capable of 10 Gb/s data rates over a distance of 300 meters and of transmitting signals with a minimum bandwidth of 200 MHz at both 850 and 1300nm. The cumulative signal loss, through connectors, jumpers, couplers, and fiber cable, shall be less than 10 dB.
- B. Upon completion of the work, the single mode optical fiber cable system shall be capable of transmitting signals with a bandwidth of up to 500 MHz at both 1310 and 1550 nm. The cumulative signal loss, through connectors, jumpers, couplers, and fiber cable, shall be less than 10dB.

1.09 GUARANTEE

- A. The Cabling System shall meet the performance requirements of the ANSI/TIA/EIA-568-C.2 standard. The warranty on the material, services, and operation of the cabling system to this specification must be for a period of at least 15 years. The connecting hardware shall have a lifetime extended warranty against defects in material and workmanship.
- B. The warranty must include the following statements regarding the cabling system:
 - 1. "Will support and conform to TIA/EIA-568-C.2 specifications covering any current or future application which supports transmission over a properly constructed horizontal cabling system premises network which meets the channel and/or basic link performance as described in TIA/EIA-568-C".
 - 2. "Will be free from defects in material or faulty workmanship for the entire warranty period".
 - 3. The Contractor shall apply for a warranty from the manufacturer within 60 days from end of project. In order to achieve a warranty the contractor must be in good standing with current training records on file.

PART 2 - PRODUCTS

2.01 ACCEPTABLE MANUFACTURERS

- A. Copper & Fiber Cable
 - 1. BerkTek, Superior Essex, Avaya, Siecor, or equal
- B. Fiber Optic Distribution Panels and Interconnects
 - 1. Leviton, ADC Telecommunications, Siecor, or equal
- C. Copper Patch Panels and Devices
 - 1. Ortronics, Leviton, Avaya, Ortronics, Siemon, or equal
- D. Cabinets and Racks
 - 1. Ortronics, ESW (Encore), Leviton, Homaco, Chatsworth, or equal
- E. Innerduct
 - 1. Eastern, Endot, or equal

- F. Firestopping
 - 1. STI (Specified Technologies, Inc.), 3M, or equal
- G. Steel Wire Cable Tray:
 - 1. Cablofil, Mono-Mesh, GS Metals, or equal
- H. Cable Runway:
 - 1. Cablofil, B-Line, Chatsworth, Mono-System Inc, or equal
- I. Fiber Optic Cable Trough:
 - 1. Ortronics, ADC Telecommunications, or equal

2.02 SYSTEM PERFORMANCE

- A. Category 6A (CAT6A) Unshielded Twisted Pair (UTP) Systems
 - 1. Category 6A 23AWG UTP copper cabling system shall be guaranteed to exceed all TIA-568 link and channel performance requirements and be capable of supporting 10G Base-T (802.3an) and ISO/IEC 11801 Class EA applications for a total distance of 100 meters with equipment cords. System shall be guaranteed to meet all CAT6A requirements for short links and channels down to a 10 foot link (5 meter channel) with a guaranteed 5 dB margin of Alien Crosstalk.
 - 2. Basis of Design is Berk-Tek Leviton Technologies CX6850 Cat6A Premium UTP System, or approved equal.
 - 3. Category 6A Performance Parameters, headroom over TIA-568 standard:

| INSERTION LOSS | NEXT | PSNEXT | ACR-F (ELFEXT) | PSACR-F (ESELFEXT) |
|----------------|------|--------|----------------|--------------------|
| 3% | 5DB | 6DB | 10DB | 10DB |

| RETURN LOSS | ACR-N | PSACR | PSANEXT | PSAACR-F |
|-------------|-------|-------|---------|----------|
| 4DB | 7DB | 7DB | 5DB | 11DB |

- A. Category 6 (CAT6) Unshielded Twisted Pair (UTP) Systems
 - 1. Category 6 UTP 23AWG copper cabling system shall be guaranteed to exceed all TIA-568 link and channel performance requirements and be capable of supporting 1000Base-T (802.3ab) and ISO/IEC 11801 Class E applications for a total distance of 100 meters with equipment cords.
 - 2. Basis of Design is Berk-Tek Leviton Technologies CX6175 CAT6 UTP System.
 - 3. CAT6 Performance Parameters, headroom over TIA-568 standard:

| Insertion Loss | NEXT | PSNEXT | ACR-F (ELFEXT) | PSACR-F (ESELFEXT) |
|----------------|------|--------|----------------|--------------------|
| 3% | 6db | 7db | 8db | 9dB |

| Return Loss | ACR_N | PSCAR | | |
|-------------|-------|-------|--|--|
| 3dB | 8dB | 9dB | | |

- B. Connectors
 - 1. Provide mission-critical, modular-type, information connectors/outlets (jacks) for 24-23 AWG copper cable. These connectors shall be individual snap-in style, and exceed compliance with TIA-568 specifications. The connectors shall comply with the following:

- a. Shall be 8-position 8-conductor (8P8C) "RJ45"-style modular jack, Category 6 (CAT6) and Category 6A (CAT6A), with IDC terminals, T568A/B wiring scheme (use T568B), and utilize a non-punchdown simplified manual termination style.
- b. Shall be encased in a die-cast housing to protect from potential EMI/RFI, and utilize a universal Keystone-style insertion footprint as the manufacturer's main "flagship" line of products.
- c. CAT6A connectors shall exceed all component performance requirements for Augmented Category 6 in the ANSI/TIA-568 standard, as well as Class EA requirements as described in ISO/IEC 11801, from 1 MHz to 500 MHz to support the IEEE 802.3an standard for 10GBASE-T network performance.
- d. CAT6 Connectors shall exceed all component performance requirements for Category 6 in the ANSI/TIA-568-C.2 standard, as well as Class E requirements as described in ISO/IEC 11801, from 1 MHz to 250 MHz. Shielded connectors shall utilize the same form factor, design, and tool-less installation process as the unshielded connectors in the product line.
- e. Shall be tested by an Independent testing body such as Intertek (ETL) for component compliance (i.e. "Component rated") to ANSI/TIA-568 and for POE+ applications. Test results shall be published and publicly available without special request.

2.03 MATERIALS

A. Copper Cable:

1. Inter-building outside-plant cable shall be multi-pair unshielded twisted pair type, #24 AWG, Superior Essex type ANMA or equal. The wiring shall comply with the following:
 - a. Maximum DC resistance: 26.5 Ohms Per 1000 feet
 - b. Maximum mutual capacitance at 1 kHz: 15.7 nF per 1000 feet
 - c. Nominal attenuation @ 1 MHz: 6.7 db per 1000 feet
 - d. Characteristic impedance @ 1.0 Hz: 1.0 MHz: 100 Ohms (+) 15%
2. Interior backbone cable shall be multi-pair unshielded twisted pair type, #24 AWG, Superior Essex AR Series Riser Cable type ARMM or equal. The cable sheath shall be armored and riser-rated (CMR). The cable shall meet ANSI / TIA / EIA-568 standards for 100 ohm category 3 UTP multi-pair backbone cable and also comply with the following:
 - a. Maximum DC resistance: 26.5 Ohms per 1000 feet.
 - 1) Maximum mutual capacitance at 1 kHz: 15.7 nF per 1000 feet
 - 2) Nominal attenuation @ 1 MHz: 7.6 db per 1000 feet
 - 3) Characteristic impedance @ 1.0 - 16.0 MHz: 100 Ohms, (+) 15%
 - 4) Inter-building and interior backbone cable shall meet the following requirements.
 - 5) Cable Conductors specifications:
 - 6) 24 AWG solid copper conductors.
 - 7) Individual conductors PVC jacketed.
 - 8) Cable construction specifications:
 - 9) Core wrap - Polypropylene film.
 - 10) Shield - Corrugated aluminum tape bonded to riser-rated jacket.
 - 11) Cable Jacket marking: Must be legible and shall contain the following information:
 - 12) Manufacturer's name.
 - 13) Copper conductor gauge.
 - 14) Pair counts.
 - 15) UL and CSA listing.
 - 16) Manufacturer's trademark.

- 17) Category rating.
 - 18) Sequential foot markings, in 1-foot increments.
 - 19) Cable jacket shall be gray with black lettering.
 - 20) Backbone cabling shall have the following characteristics:
3. Horizontal distribution cable in conduit shall consist of four unshielded twisted pairs, #23 AWG, BerkTek Lanmark Cat. 6A type CMR or equal, with the following characteristics: Cable shall be characterized to 750 MHz and UL/ETL Listed by the Manufacturer printed on the cable jacket and package, as well as Intertek (ETL) Verified to TIA-568 Category 6A and ISO/IEC 11801 Class EA requirements for channel, link and component performance to support IEEE 10GBASE-T (802.3an) networks.
 - a. Horizontal distribution cable, where not installed in conduit in plenum spaces, shall be plenum rated and consist of four unshielded twisted pairs, #23 AWG, BerkTek Lanmark Cat. 6A type CMP or equal, with the following characteristics: Cable shall be characterized to 750 MHz and UL/ETL Listed by the Manufacturer printed on the cable jacket and package, as well as Intertek (ETL) Verified to TIA-568 Category 6A and ISO/IEC 11801 Class EA requirements for channel, link and component performance to support IEEE 10GBASE-T (802.3an) networks..
 - b. Horizontal cable shall meet the following requirements.
 - c. Cable jacket marking: Must be legible and shall contain the following information:
 - d. Manufacturer's name.
 - e. Copper conductor gauge.
 - f. Pair counts.
 - g. UL and CSA listing.
 - h. Manufacturer's trademark.
 - i. Category rating.
 - j. Sequential foot markings, in 2-foot increments.
 - k. Telecom station (and wireless antenna) cable jacket shall be blue with black lettering and shall be in 1000-foot boxes.
 - l. The jacket for telecom cabling serving AV devices and equipment shall be yellow with black lettering and shall be in 1000-foot boxes.
 - m. Type CMR cable shall be solid annealed copper with polyolefin insulation round design with flexible web separator with flame retardant PVC jacket.
 - n. Type CMP cable shall be same as Type CMR except with type FEP insulation.
 4. Data Equipment Inter-Connect patch Cords: Four twisted-pair stranded, Category 6A, 24 AWG copper conductors. Individual conductors PVC jacketed. Each conductor provided with unique color code. Manufacturer terminated on each end with Ortronics or Systemax Category 6A 8-pin / 8-position modular plug to be pinned as per EIA / TIA 568 C. Connector plug shall be polarized to prevent polarity reversal or split pairs, and shall be factory-marked to indicate top of connector. Inter-connect cord shall be UL listed.
 - a. The Contractor shall complete data interconnects between patch panels and Owner-provided active network electronics.
 - b. Lengths as required running from the data station cable terminations to the ports on equipment mounted in any rack position. Minimum length shall be 5 feet and the maximum length shall be 15 feet.
 - c. Voice Cross-Connect Wire (for use on facilities where voice cables are terminated on blocks): One and Two twisted pair, 24 AWG solid copper conductors. Individual conductors PVC jacketed. One pair shall be yellow/blue color code and 2 twisted pairs shall be red/blue and red/orange coded. Must be UL listed for use as cross-connect wire. Provide one 1,000 foot reel of each type for use by Owner.
 - d. Contractor to assist Owner to perform all voice cross-connects.
 - e. Minimum performance specifications:

- f. Cross-connect wire used on "voice" (telephone) cross-connects must meet the EIA/TIA 568 B impedance, attenuation and NEXT requirements for Category 3 horizontal cable.

B. Fiber Optic Cables

1. The mechanical and environmental specifications for fiber optic cable shall be in accordance with ANSI/TIA-492.AAAC-B, Bellcore, FDDI, and NEC sections 770 standards. Optical fiber cables run shall be low-water-peak multimode or singlemode (OS2), and meet all of the requirements delineated within the specifications of ANSI/TIA-568.
 - a. Cable shall meet/exceed Bellcore TR-TSY-000020, FDDI and NEC sections 770-6(b) and (c) standards.
 - b. Strand counts shall be per drawings.
 - 1) Multimode inter-building (exterior) backbone fiber optic cable shall be outside plant rated, with number of multimode strands as noted on the drawings, with dielectric central member, non-armored, water-blocking material, ripcord, dielectric strength member over loose buffer tubes, and polyethylene jacket, Superior Essex TeraGain (11---6G01) Loose Tube Single Jacket All-Dielectric Cable or equal, and shall meet/exceed the following cable characteristics:
 - (a) Multimode Core/Cladding size: 50/125um
 - (1) Maximum attenuation: 3.5 dB/km @ 850nm, 1.0 dB/km @ 1300 nm
 - (2) Minimum bandwidth: 200 MHz-km @ 850nm, 500 MHz @ 1300nm
 - 2) Multimode indoor backbone fiber optic cable shall be plenum rated, with number of multimode strands as noted on the drawings, with dielectric central member, non-armored, ripcord, dielectric strength member over TB11 buffered fiber, PVC jacket, Superior Essex TeraGain (44---6G01) or equal, and shall meet/exceed the following the following cable characteristics:
 - (a) Multimode Core/Cladding size: 50/125um
 - (1) Maximum attenuation: 3.75 dB/km @ 850nm, 1.00 dB/km @ 1300nm
 - (2) Minimum bandwidth: 200 MHz-km @ 850 nm, 500 MHz-km @ 1300nm
 - 3) Singlemode inter-building (exterior) backbone fiber optic cable shall be outside plant rated, with number of single mode strands as noted on the drawings, with dielectric central member, non-armored, water-blocking material, ripcord, dielectric strength member over loose buffer tubes, and polyethylene jacket, BerkTek, Superior Essex (11---9T01) Loose Tube Single Jacket All-Dielectric Cable or equal, and shall meet/exceed the following cable characteristics:
 - (a) Single mode Core / Cladding size: 8.31/125um
 - (b) Maximum attenuation: 0.40 dB/km @ 1310nm, 0.30 dB/km @ 1550nm
 - 4) Singlemode indoor backbone fiber optic cable shall be plenum rated, with number of single mode strands as noted on the drawings, with dielectric central member, non-armored, ripcord, dielectric strength member over TB11 buffered fiber, PVC jacket, BerkTek, Superior Essex (44---9101) or equal, and shall meet/exceed the following cable characteristics:
 - (a) Single mode Core/Cladding size: 8.3/125um
 - (b) Maximum attenuation: 0.40 dB/km @ 1310nm, 0.30 dB/km @ 1550nm
 - 5) Composite singlemode/multimode inter-building fiber optic cable shall be non-plenum rated, with number of single mode and multi-mode strands as noted on the drawings, with dielectric central member, non-armored, water-blocking material, ripcord, dielectric strength member over loose buffer tubes, and polyethylene jacket, Superior Essex TeraGain Loose Tube Single

Jacket All-Dielectric Cable or equal, and shall meet/exceed the following cable characteristics:

- (a) Multimode Core/Cladding size: 50/125um
- (b) Multimode maximum attenuation: 3.5 dB/km @ 850 nm, 1.0 dB/km @ 1300nm
- (c) Multimode maximum bandwidth: 200 MHz-km @ 850nm, 500 MHz-km @ 1300nm
- 6) All cable assemblies are to be Leviton Opt-X type or equal.
- 7) General Fiber Optic Cable Requirements:
 - (a) See the Drawings for required fiber counts and routing.
 - (b) ANSI/EIA/TIA-568.3-D.
 - (c) The cable manufacturer must guarantee the supplied single mode fiber optic cable will meet the specifications covering latest following standards and network applications using standard off-the-shelf, non-proprietary network hardware:
 - (d) OC-12 625 Mb/s
 - (e) OC-48 1024 Mb/s
 - (f) IEEE 1000 Base SX 1000 Mb/s
 - (g) ATM 625 Mb/s
 - (h) ATM 1.2 Gbps
 - (i) Fibre Channel 1.062 Gbps
- 8) Fiber optic cable sheath construction shall be of a tight-buffered MIC style design with integrated strength member.
- 9) The fiber optic cable shall have an integrated strength member, which is a high tensile strength dielectric providing axial strength and anti-buckling properties for the fibers.
- 10) The fiber optic cable shall utilize aramid yarn as a flexible strength member surrounding the buffered fibers beneath the cable jacket.
- 11) The individual fibers in a tight-buffered fiber optic cable shall be placed in groups of 6 or 12 fiber strands per subunit.
- 12) The individual subunits shall be color coded for easy identifications.
- 13) The cable tensile load rating shall be a maximum of 461 lbf for a 24-fiber count 6-fiber subunit.
- 14) The cable minimum bend radius at 0-150lbs pulling or handling load shall be 10 times the outside diameter of the sheath.
- 15) The cable minimum bend radius at 151-600 lbs pulling or handling load shall be 20 times the outside diameter of the sheath.
- 16) The fiber optic cable shall be low smoke, flame retardant and shall meet the flame test requirements of UL 910. It shall be UL listed as OFNP.
- 17) Multimode fiber optic connectors shall be duplex SC.
- 18) Fiber optic patch cables SC to SC shall be duplex with an oval over-sheath. Each fiber shall be labeled 'A' or 'B' to provide fast identification of "Transmit" and "Receive" fibers in patching between network electronics and backbone connections. Fiber optic duplex patch cables shall be provided in a 15 foot length as follows:
 - (a) Avaya FL3EP-EP-15 or Leviton 5LDLC-M05.

C. Data Outlets

1. Cable termination hardware shall be individual; Category 6A rated Leviton (or equal) jacks. The listed product shall have the following characteristics:

- a. One eight-position, eight-conductor jack (non-keyed), TIA/EIA-568-C Compliant, wired to T568B, Leviton category 6A.
 - b. The cover of the information outlet shall be labeled above the jack. The number on the outlet jacks shall coincide with the identification requirements listed in Part 3 of this Section below.
 - c. The color of all general use jacks shall be blue.
 - d. The color of all jacks at AV-related devices or racks shall be yellow.
 - e. The color of all faceplates and blank inserts or visible mounting plates shall match the adjacent power or signal outlet covers on the project (provided under another Section).
 - f. The devices at outlets and the devices in the patch panels shall be of the same manufacturer and same type.
 - g. See Drawings for number of jacks at each outlet, jack arrangement, and mounting type.
 - 1) The 8-pin 8-position jacks at terminal blocks and at each 4-pair termination shall be labeled with laser-printed polyester self-laminating wrap-around labels.
 - (a) Eight-pin 8-position jack label-faceplates;
 - (1) All labels shall be polyester and white in color;
 - (2) All labels shall be 1.80-inch in width and 0.375-inch in length;
 - (3) Labels shall have an adhesive backing;
 - (4) Labels shall be attached to the faceplate by adhesive and clipping in behind the snap in clear plastic cover;
 - (5) Labels shall be laser printed with the labeling scheme as specified;
 - (6) Labels shall be Panduit Pan-CODE Laser Labels (PLL) part EFPL-1, Leviton LabelWare, or equal.
 - (7) Terminal block designation strip:
 - (8) All labels shall be polyester;
 - (9) Labels shall be white in color for 4-pai data station cable terminations, located within a blue plastic label holder;
 - (10) Labels shall be attached to the designation strip provided with the blue plastic holders;
 - (11) All labels shall be 7.88 inches in width and 0.50 inches in length;
 - (12) Labels shall have an adhesive backing;
 - (13) Labels shall be laser-printed with the labeling scheme as specified;
 - (14) Labels shall be Panduit Pan-CODE Laser Labels (PLL) part number PLL-22-Y3-1, Leviton LabelWare, or equal.
 - (15) Labeling for all cable, jacks, and other elements of the telecom cabling system shall follow TIA/EIA-606 Standards. Provide color-coded labels for all wiring blocks as follows:
 - (16) Interface to Site Cabling - Brown
 - (17) Interface to Equipment Cabling - Purple
 - (18) Interface to Horizontal Cabling - Blue
 - (19) Interface to Telephone Company - Green
- D. Termination Hardware at IDF's (Fiber Optic)
 1. Optical Fiber Interconnect Equipment: Interconnect equipment shall be mounted on two or four post equipment racks as indicated on the drawings. Interconnect equipment shall be affixed to the rack by at least (4a) screws. The screws shall be the correct size and thread configuration for the holes in the rack. The screws shall be tightened to the extent that they hold the equipment firmly to the rack, without distorting the equipment or

- stripping the threads. All optical fiber interconnect devices shall be assembled and installed in accordance with the manufacturer's instructions and recommendations.
2. Fiber Interconnect Equipment shall be of sufficient size to permit termination of all fiber strands, maintaining minimum bend radius for both multimode and singlemode cables, and maintaining required cable storage. In the event that an enclosure must be oversized (number of termination ports) due to manufacturer's product standardization, the next larger available enclosure size shall be utilized.
 3. Adapter plates, which accommodate Duplex SC type connectors, shall be provided within each Fiber Optic Distribution Panel (unless otherwise noted on the drawings). Multimode and Singlemode connectors (quantity and type as indicated on the drawings) shall be included on adapter plates.
 - a. The duplex SC adapter at the main distribution frame (MDF) shall be mounted in a B-A configuration.
 - b. The duplex SC adapter at each intermediate distribution frame (IDF) shall be mounted in an A-B configuration for cables coming from the MDF, and in a B-A configuration for cables going to an additional IDF (if applicable) further downstream.
 - 1) Fiber optic distribution panels shall be rack-mount type, utilizing Leviton Opt-X fiber System components, or equal, with fiber capacity as indicated on the drawings, equipped with snap-in adapter panels.
 - (a) Provide quantity of connector panels for complete termination of all fiber strands, complete with duplex SC adapters.
 - (1) Provide blank connector plates for all spaces not equipped with adapter panels.
 - (2) All glass strands of each fiber optic cable shall be terminated on Leviton Fast Cure type duplex SC connectors which require no epoxy or heat cure devices, allow re-termination to reduce waste, and have the following characteristics:
 - (3) Ceramic ferrule
 - (4) 568SC style
 - (5) Plastic housing
 - (6) Low loss - 0.2 db (typical), 0.5 (guaranteed)
 - (7) All inter-building fiber optic cables (loose tube type) shall be terminated at fiber optic distribution panels using a Leviton 49887 Series (or equal) buffer tube fan-out kit.
 - (8) Labeling for fiber optic cabling and distribution panels shall match the labeling system for data cabling and hardware.
- E. Termination Hardware at IDF's (Data)
1. All cables installed application shall be terminated in rack-mounted modular patch panels and the entire installation shall be in compliance with TIA/EIA-568-D Category 6A requirements.
 2. Patch panels shall be Leviton Category 6A discrete port-type. Port panels shall be certified by the manufacturer as suitable for 1000 Mbps data transmission. Patch panels shall be manufactured of aluminum or steel.
 3. Wire management hardware shall be Leviton Versi-Duct 49265 Series, or equal, installed at both the top and the bottom and between each patch panel and along the sides of the rack for patch cable routing and management.
 4. Wire managers shall be of sufficient width and depth to permit orderly routing of all patch cables at one hundred percent utilization.

5. Patch panels shall be mounted on equipment racks. Panels shall be affixed to the rack by at least four (4) screws. The screws shall be of the correct size and thread configuration for the holes in the rack. They shall be tightened to the extent that they hold the equipment firmly to the rack, without distorting the equipment or stripping the threads.
6. Patch panel quantity of ports as noted on the drawings.
 - a. Termination Hardware at MDF / IDF's (if voice cables are indicated on the drawings to be terminated at 110 blocks rather than at patch panels)
 - 1) All cables installed for voice application shall be terminated in accordance with industry standards on 110S type wiring blocks.
 - 2) Avaya or Leviton 110A type wiring blocks with metal backboard category 6A insulation displacement style, or equal shall be installed with sufficient spacing to permit the orderly routing of jumper cables between wiring blocks, and wire management accessories shall be provided for each 110 block.
 - 3) UTP cable terminating blocks: Compact 110-type or equal Category 6A insulation displacement terminal blocks complete with mounting hardware, connecting blocks, retainers, wire guides, designation strips, etc, UL listed.
 - (a) Minimum performance specifications: Must meet EIA/TIA 568-D requirements for Category 6A.
 - (b) Avaya Systimax or Leviton Category 6A - 110 Cross Connect System Terminal block kit in 300 pair configuration with vertical cable manager.
 - (c) Leviton Category 6A 300-pair Vertical Cord Manager, Basic Unit, with bottom cable tray, with vertical cable manager each side.
 - (d) Or equal.
 - (1) Wiring blocks, metal frame, and cable managers shall be mounted to plywood backboards. Each frame or wire management accessory shall be mounted such that its horizontal dimension is level. All blocks shall be aligned vertically. Each block shall be affixed to the plywood backboard by means of screws suitable for fastening to plywood. A minimum of four (4) of the mounting holes provided shall be utilized for fastening. Screws shall be tightened to the extent that they hold the frame or wire management accessory snug to the backboard, but not so tight as to distort or damage the device. Wiring blocks shall be terminated in accordance with the manufacturer's instructions and recommendations. Installation of wire management accessories shall also be conducted in accordance with the manufacturer's instructions and recommendations.
 - (2) Labeling at wire troughs and for all cable, jacks, and other elements of the voice/data cabling system shall follow TIA/EIA-606 Standards. Provide color-coded labels for all wiring blocks as follows:
 - (3) Interface to Site Cabling - Brown
 - (4) Interface to Equipment Cabling - Purple
 - (5) Interface to Horizontal Cabling - Blue
 - (6) Interface to Telephone Company - Green

F. Equipment Racks

1. Communication Cabinets - Wall Mounted
 - a. Wall mounted communication cabinets shall be utilized wherever noted on the drawings, to provide adequate mounting space for patch panels, wire managers, fiber optic distribution panels, and network integration equipment.
 - b. Height of cabinet shall be as noted on the drawings. The cabinet shall be provided with 19" equipment mountings and shall have the following physical characteristics:

- 1) Depth suitable for mounting of equipment up to 18 deep.
- 2) Cabinet shall be supplied with front and rear equipment mounting rails, drilled and tapped to a 5/8", 5/8", 1/2" hole pattern.
- 3) Finish shall be black powder coat finish.
- 4) Locking front Plexiglas door.
- 5) Vented top and bottom/back open for cable entry.
 - (a) Wall mounted communications cabinet shall be Chatsworth Cube-IT or equal, minimum 24" deep, 24" wide and 36" high.

PART 3 - EXECUTION

3.01 CABLE AND WIRE INSTALLATION:

- A. This contractor shall be responsible for the provision and installation of all telecom cables including all supports, hangers, and hardware necessary for a complete installation. Under no circumstances shall cables be laid on the suspended ceiling. This contractor shall be responsible for providing and installing all necessary cable support hardware to meet Category 6A requirements. Refer also to Section 26 27 00 Basic Materials & Methods:
 1. T-Bar Suspended Ceilings: Copper station cabling may be run outside of conduits when routed above T-Bar suspended ceilings. Cables installed in this fashion are to be run horizontally in bundles and tied down neatly suspended from J-hooks, and well clear of any light fixtures or other electrical appliances that may affect data transmissions.
- B. At each telecom room cables are to be segregated by type, neatly tied together, properly dressed, and routed to the patch panels. All cables shall be tagged.
- C. Cable distances from patch panels to data outlet shall not exceed 295 feet. This contractor is responsible to ensure the distance specified is not exceeded.
- D. Care shall be exercised in routing both station and backbone/tie cables so as to avoid areas where sources of high levels of EMI (such as electric motors, transformers and fluorescent lighting fixtures) may exist. Maintain a minimum distance of 12" for voltages of 3KVA or less and 36" separation for voltage of 5KVA and more from these sources when run parallel. Cross at 90-degree angles where crossing must occur.
- E. Each station cable shall be "home run" (no splices or cross connection points) between jacks and patch panels.
- F. All openings or raceway transitions through firewalls and floors shall utilize UL listed fire-rated penetrations.
- G. The fiber optical cable manufacturer's installation instructions shall be followed in order to avoid damage during placement within the facility. All fiber optic cable shall be placed within innerduct to provide mechanical protection and to provide visual warning or caution when handling or other work operations are performed adjacent to the installed fiber cable.
- H. No more than (2) 90-degree bends shall be allowed on all conduit runs for the horizontal voice/data cabling system, without an intermediate pullbox or junction box.
- I. Station cable terminations.
 1. Cable pair twists of Category 6A Cable shall be maintained within 0.5-inch of the point of termination. Under no circumstances shall cable pairs be untwisted or otherwise altered prior to termination.
 2. Do not bend Category 6A station cables to a radius of less than 4 times the cable diameter - approximately 2-inches.
 3. Allow slack in Category 6A cable bundles at entrances and exits of conduit sleeves and at transitions from "J" hooks to cable trays. Do not exceed maximum 25 pounds of pulling tension on cabling. Never pull cables tight at cable tray transitions; doing so may damage the cables by crimping them on the cable tray side of the bundles.

4. Keep the cable evenly distributed within the cable tray. Do not allow the cables or bundles to be pulled tight against the splines or to be unevenly balanced on one side of the tray.
 5. Bundles of station cable in floor slots shall not exceed 2.5 inches in diameter, and shall be spaced 4 inches apart for proper fire stopping of the floor slot.
 6. Bundles of station cable in 4-inch floor sleeves shall not exceed a 39 percent fill.
- J. Fiber optic cable and termination installation.
1. The Contractor shall place all optical fiber backbone cabling in accordance with these Specifications, and as indicated on the Drawings.
 2. Fiber optic cables: After dressing the cable to its final destination, sheath shall be removed to a point that allows the strands to be placed in break out kits to be splayed and terminated in a neat and uniform fashion. At this point all fibers shall be terminated in strict compliance with the manufacturer's submitted instructions.
 - a. Cable sheaths shall be clamped to the outside of fiber termination shelf. The cable clamp shall be manufactured by the manufacturer of the termination shelf and shall be designed to clamp outside plant fiber optic cable sheaths.
 - b. The tight-buffered sheath cable shall have the OFNR sheath and Kevlar strength members terminated at the cable clamp on the outside of the shelf. Only the buffer tubes and buffered fibers shall continue into the termination shelf.
 - c. Provide a minimum of 48-inches of subunit buffer tube and 40 inches of buffered fiber inside of the termination shelf.
- K. Where fiber or copper cable enters an equipment room, it shall be affixed to the backboard via "D" Rings and cable ties. All cable shall be neatly bundled, combed, and tied. All exposed cable runs shall be horizontal or vertical, and bends shall comply with manufacturer required minimum cable bending radii.
- L. All openings into wall mounted cabinets and fiber optic distribution panels shall have grommets for the protection of cabling.
- M. Fiber innerduct shall be installed in accordance with manufacturer's instructions and industry standards. Within the equipment rooms, the innerduct shall extend from the end of conduit to (4) feet above the floor and shall be affixed to the backboard by means of clamps designed for that purpose. Care shall be taken to avoid kinking the innerduct or applying excessive tension during the installation process.
1. Innerduct runs do not have to be continuous throughout. Breaks are acceptable at pull boxes where required. This contractor is responsible for determination of actual lengths of innerduct required. This contractor is responsible for determination of actual lengths of innerduct required. Enough innerduct shall be provided and installed to extend from the fiber service loops at the MDF to the fiber service loops at each IDF. In pullboxes, segments of innerduct shall extend a minimum of (12) inches into the pullbox.
- N. During installation of optical fiber cable in conduit, special care shall be taken to avoid damage to the cable. While under pulling tension, the cable shall not be bent into a curve with a radius of less than (20) times the cable diameter. Pulling tension shall not exceed manufacturer's recommended maximum tensile load. Contractor shall utilize a winch with tension control or a "break-away" link designed to break away at or below the recommended maximum tension.
- O. A minimum (30) foot service loop shall be provided at each terminal location for all fiber optic cables. Provide service loop via backboard attached cable reels.
- P. Each end of gel-filled voice cable shall be dammed at the breakout point-using manufacturer recommended blocking kit. All pairs extending beyond the breakout point and dam shall be cleaned such that no gel remains.

- Q. Provide (1) patch cable for each activated jack on the project. Lengths shall be 5ft. minimum or as required for the MDF or IDF design. Patch cords shall be factory tested to ensure compliance with current standards.
- R. Provide one fiber jumper for each two strands of fiber at each equipment rack, with duplex SC type connectors unless otherwise noted on the drawings.
- S. Labeling: Labeling shall include, but not be limited to:
 - 1. Labeling telecommunications outlet faceplates;
 - 2. Labeling station cables;
 - 3. Labeling terminal blocks;
 - 4. Labeling fiber optic cable sheaths;
 - 5. Labeling fiber optic and copper splice closures;
 - 6. Labeling fiber optic stands;
 - 7. Labeling fiber termination panels;
 - 8. Labeling of telecommunications equipment racks and fiber frames;
 - 9. Labeling of telecommunications pathways, including conduits, steel wire cable trays, cable runway and pullboxes;
 - 10. Labeling of all grounding conductors and ground bars in the Intermediate Distribution Facilities (IDFs) and Main Distribution Frame (MDF).
 - 11. The intent of the final labeling is to allow the Owner or persons contracted by the Owner to identify any part of the structured cabling system through physical identification of the components and their related components at the specified access point without the use of electrical, electronic or mechanical means of identification.
 - 12. Equipment rack and cable tray / pullbox labels:
 - a. Equipment Racks shall be clearly labeled as follows:
 - 1) Labels shall be adhesive backed individual letters and numbers.
 - 2) Individual letters shall be 3/4*-inch in width and 1-inch in height.
 - 3) Individual characters shall be self-spacing by simply butting the individual characters against each other in a row.
 - 4) Characters shall be either white or yellow on a black background.
 - 5) Labels shall be designed for exposed outdoor applications.
 - 6) Labels shall be:
 - (a) 3M Scotchcal 5003 Non-Reflective Lettering Systems.
 - (b) Panduit, PVL100YB.
 - (c) Or equal.
 - b. Cable Tray Labeling:
 - 1) Cable tray shall be provided with a label clip fastened to the underside.
 - 2) Label clip shall be 3.94-inches wide by 0.63-inch high and shall attach to the cable tray without the use of additional fasteners;
 - 3) Label clips shall be attached to each label clip:
 - 4) All labels shall be polyester with white color;
 - 5) All labels shall be at least 3.00 inches in width and 0.38-inch in length;
 - 6) Labels shall have an adhesive backing;
 - 7) Labels shall be attached to label clips with the adhesive back self-laminating portion;
 - 8) Labels shall be laser printed with the labeling scheme as specified;
 - 9) Label shall be 0.25-inch high, Ariel San Serif;
 - 10) Labels shall be Panduit, Pan-CODE Laser Labels (PLL) part number PLL-19-Y2, or equal.
 - c. Labeling at Pull Box:

- 1) Cover and interior labeling for pull box:
 - 2) All labels shall be polyester with white color;
 - 3) All labels shall be at least 1.88- inches in width and 0.83-inch in length;
 - 4) Labels shall have an adhesive backing;
 - 5) Labels shall be attached on cover and interior of pullbox at locations indicated on the Drawings with the adhesive back self-laminating portion.
 - 6) Labels shall be laser printed with a labeling scheme approved by the Owner's Representative.
 - 7) Label shall be 0.25-inch high, Ariel San Serif;
 - 8) Labels shall be Panduit, Pan-CODE Laser Labels (PLL) part number PLL-19-Y2, or equal.
- d. Cover and interior labeling for conduit at pull box:
- 1) All labels shall be polyester with white color.
 - 2) All labels shall be at least 1.88- inches in width and 0.83-inch in length;
 - 3) Labels shall have an adhesive backing;
 - 4) Labels shall be attached on cover and interior of pullbox with the adhesive back self-laminating portion at location where conduit enters the pullbox.
 - 5) Labels shall be laser printed with a labeling scheme approved by the Owner's Representative.
- e. Copper station - cable sheath labels:
- 1) Copper station cable sheaths at 8-pin 8-position jacks, at junction boxes, enclosures, and pull boxes shall be labeled with laser-printed polyester self-laminating wrap-around labels.
 - 2) All labels shall be polyester with white color.
 - 3) All labels shall be at least 1.00- inches in width and 1.33-inch in length; with a 0.5-inch x 1-inch printable area;
 - 4) Labels shall have an adhesive backing;
 - 5) Labels shall be attaché to cable sheaths by wrapping around the sheath with the adhesive back self-laminating portion;
 - 6) Labels shall be laser printed with the labeling scheme as specified;
- f. Cable / outlet / jack / termination identification:
- 1) Each copper cable, its associated jack at the outlet, and the associated C-4 connecting block on the terminal block or patch panel shall be labeled with a unique identifier consisting of the following:
 - 2) The IDF room number where the station cable is terminated, ###.
 - 3) The end user room number in which the 4-pair cable is terminated and the telecommunications outlet is located, ###.
 - 4) A 3-digit serial number, rest to 001 for each room, which sequentially identifies each telecommunications jack / cable in a room, ###.
 - 5) The type of service provided by a Particular cable, either D for data or V for voice.
 - 6) Example of IDF 107, user room 129, jack /cable number 1 (data cable):
107-129-001-D.
 - 7) The following are examples of the numbering scheme:
 - 8) IDF room 1.1, User Rm. 111, Jack/ cable 1, Data line.
 - 9) 1.1-111-001-D
 - 10) IDF Number: 1.1
 - 11) Room Number: 111
 - 12) Serial Number: 001
 - 13) Data Line: D

- 14) IDF room 1.1, User Rm. 106, Jack / cable, Voice line.
- 15) 1.1-106-001-V
- 16) IDF Number: 1.1
- 17) Room Number: 106
- 18) Serial Number: 001
- 19) Voice Line: V
- 20) Cable identification:
- 21) Each fiber optic backbone cable sheath shall be labeled with a unique identifier as shown on the Drawings.
- 22) Label the cable sheath at the termination shelf and on the innerduct as the fiber optic cables pass through IDFs and pull boxes.
- 23) Each SC connector in each termination shelf shall be labeled with a unique identifier as noted on the Drawings.
- 24) Cable sheath identification:
- 25) Identify multi-pair copper riser cable sheaths with machine-generated labels at the following locations:
 - 26) Within 12 inches of the point that the cable exits the top or bottom of the 110P-type terminal block column.
 - 27) Within 12 inches of the point that the cable enters a splice.
 - 28) At 40-foot intervals above T-Bar ceilings.
 - 29) At pull boxes
 - 30) Within 12 inches of the point that the cable enters or exits wall and floor sleeves.
- 31) Warning Tags: At each location where fiber cable is exposed, it shall be marked with warning tags. These tags shall be yellow or orange in color, and shall contain the warning: "CAUTION FIBER OPTIC CABLE". The text shall be permanent, black, block characters, and at least 3/16 high. A warning tag shall be permanently affixed to each exposed cable or bundle of cables, at intervals of not more than (5) feet. Any section of exposed cable, which is less than five (5) feet in length, shall have at least one warning tag affixed to it.

3.02 GROUNDING SYSTEM AND CONDUCTORS

A. Bonding and Grounding:

1. Communication bonding and grounding shall be in accordance with the NEC and NFPA. Guidelines of ANSI/TIA-607-C shall be followed. Horizontal cables shall be grounded in compliance with ANSI/NFPA 70 and local requirements and practices. Horizontal equipment includes cross connect frames, patch panels and racks, active telecommunication equipment and test apparatus and equipment.

B. Telecommunications Bonding Backbone:

1. Provide a Telecommunications Bonding Backbone utilizing a minimum #6 AWG bonding conductor (or as shown on drawings) that provides direct bonding between equipment rooms and telecommunications closets. Connect this bonding backbone cable to the main grounding electrode system at the electric service switchboard.
2. Provide a copper ground bar at each telecommunications equipment room or rack location, connected to the bonding backbone.
3. Provide a #6 AWG stranded copper cable from each ground bar to each adjacent rack or cable trays system.

3.03 LIGHTNING PROTECTION BLOCKS

A. Protection:

1. Provide protection blocks at each building entry for copper site cable terminations; as manufactured by Circa, or equal.

2. Provide sufficient capacity for protections of all pairs.
3. Materials: As indicated on the Drawings.

3.04 FIRE AND SMOKE PARTITION PENETRATIONS

- A. Conduit sleeves shall be provided as part of this contract as a means of routing cables through fire-rated walls and floors. Openings in sleeves and conduits used for system cables and those that remain (empty) spare shall be sealed with an approved fireproof, removable sagging material at completion. Sleeves, which pass vertically from floor to floor, shall be sealed in a similar manner using an approved re-enterable system. Additional penetrations through rated assemblies, necessary for passage of voice/data wiring, shall be made using an approved method and permanently sealed after installation of cables. UL systems must be available for each firestop penetration and included in the submittal. All firestop products must be readily available at local electrical and/or telecom distribution outlets.

3.05 PLYWOOD BACKBOARDS

- A. Provide backboards shall be fire retardant, 3/4-inch A-B grade plywood, void free, 2440-mm (8 feet) high unless otherwise noted, capable of supporting attached equipment, and painted with a minimum of 2 coats of fire retardant off-white semi gloss paint. Manufacturer's stamps visible from the front side of the plywood backboard shall be masked to painting.
- B. Plywood backboards shall be fastened to the structural members of the building only using an approved fastener. Plywood backboards shall not be anchored to GBW.
- C. Plywood shall be mounted from +6-inches AFF to +8 feet 6-inches at the locations indicated on the Drawings.
- D. Plywood backboards shall be cut to fit in width and shall have holes cut into the backboard to accommodate and provide access to devices behind the backboard, such as switches and outlets.

3.06 TESTING AND DOCUMENTATION

- A. Fiber Optic Cable Test Equipment:
 1. Cable tester shall be NRTL certified for compliance to be used as an Optical Loss Test Set.
 2. Cable testers shall be Optical Power Meter and High Resolution Optical Time Domain Reflectometer (OTDR). The cable tester shall be NRTL certified for compliance to latest TIA/EIA performance requirements at 850, 1300, 1310 and 1550 nm.
 3. Testers shall have been calibrated at least one year prior to use on this project. Calibration must be in accordance to IEC 61315 and IEC 61746 respectively. Contractor to provide proof to Owner if requested.
 4. All testing equipment (OTDR, Light Loss, Splicer etc.) shall be owned by the Contractor. Contractor must prove ownership of equipment if requested
 - a. Cable segments and links shall be tested from both ends of the cable for each of the construction phases. (Verify that cable labeling matches at both ends).
 - 1) The system will not be considered certified until the tester has certified to the Owner that the performance of the physical layer of the system has been fully tested and is operational at the completion of the installation phase.
 - 2) Testing Procedures:
 - (a) Perform each visual and mechanical inspection and electrical test, including optional procedures, stated in NETA ATS, Section 7. Certify compliance with test parameters and manufacturer's written recommendations. Test optical performance with optical power meter capable of generating light at all appropriate wavelengths.
 - (b) Prior to testing, all connectors shall be properly cleaned with an approved product manufactured specifically for this purpose.

- (c) Prior to beginning testing, confirm that all testing equipment is fully charged or operating on building power. If the test equipment power levels drop below 50%, recharge unit or continue testing with a different (fully charged) tester.
 - (d) All testing shall comply with latest standards, requirements, and procedures of ANSI/TIA/EIA. Tests shall be conducted using ANSI/TIA-526-14A, Method B. Test results evaluation for the panel to panel (backbone) shall be based on the values set forth in ANSI/TIA-568.
 - (e) Initially test optical cable with a light source and power meter utilizing latest Tier 1 procedures as stated in TIA/TSB-140.
 - (f) Measured results shall be plus/minus 1 dB of submitted loss budget calculations. If loss figures are outside this range, test cable with Optical Time Domain Reflectometer (OTDR) to determine cause of variation. Correct improper splices and replace damaged cables at no charge to the Owner.
- 3) Fiber Optic Cables:
- (a) Shall be tested bi-directionally for length and attenuation at both the short and long wavelengths as specified in TIA TSB-140.
 - (b) Single-mode fibers shall be dual wave length and provide attenuated wavelength of the 1310 nm and 1550 nm. 850 nm for single-mode fiber shall not be acceptable under any circumstances. Multimode shall be tested at 850nm and 1300nm.
 - (c) After installation of connectors, visually inspect each fiber end-face at 10X magnification. Refinish fibers with visible defects and / or striations in the core area.
 - (d) Demonstrate that measured link loss does not exceed the "worst case" allowable loss, defined as the sum of the connector losses (based on number of mated connector pairs at the EIA / TIA 568 maximum allowable loss of 1.5dB per mated pair), the optical fiber loss (based on length) and the EIA / TIA 568 maximum allowable loss (3.75dB/km @ 850nm and 1.0dB/km @ 1300nm).
 - (e) Strands whose measured attenuation fall outside the acceptable range shall be subject to further inspection and testing to determine the nature of the fault. At a minimum, an OTDR shall be used to determine the true loss for each connector pair, the exact length of the fiber and to identify the presence of any core damage.
 - (f) Faults related to connectorization shall be corrected, and the fiber re-tested, until acceptable attenuation measurements are recorded.
 - (g) Where defects are found to be inherent in the fiber itself, replace any cable having fewer than the manufacturer's guaranteed number of serviceable fibers.
 - (h) All fiber optic test instruments used on the site shall be capable of storing test data files and downloading these test results as data files. The fiber optic strand number shall be used as the record identifier for each test.
 - (i) All OTDR traces shall be delivered to the Owner's Representative in electronic format. The Contractor shall provide the Owner's Representative with software to read the OTDR traces. The application software shall be licensed to the Owner.
 - (j) All Power meter readings shall be provided in a file format capable of being inserted into a Microsoft Excel spreadsheet for review. Power meter

readings shall be delivered to the Owner's Representative in electronic format.

- 4) All cables shall be tested after termination using a cable certification tester that contains the test equipment manufacturer's most current version of firmware.
- 5) Upon completion of testing, all connectors shall be capped with a product made for that specific function by the connecting hardware manufacturer to prevent the contamination of the fiber from construction debris or other foreign objects.
- 6) Test Results:
 - (a) The test results information for each link shall be recorded in the memory of the field tester upon completion of the test. The tester shall be capable of storing test data in either internal or external memory. The external media used shall be left to the discretion of the user.
 - (b) Test results saved by the tester shall be transferred into a Windows based database utility that allows for maintenance, inspection and archiving of these test records. A guarantee must be made that the measurement results are transferred to the PC unaltered as well as any printed reports generated from the software application.
 - (c) The test results information for each link shall be recorded in the memory of the field tester upon completion of the test. The tester shall be capable of storing test data in either internal or external memory. The external media used shall be left to the discretion of the user.
 - (d) Test results saved by the tester shall be transferred into a Windows based database utility that allows for maintenance, inspection and archiving of these test records. A guarantee must be made that the measurement results are transferred to the PC unaltered as well as any printed reports generated from the software application.
 - (e) Optional formats of data reporting are: comma separated variable (.csv), Portable Document File (.pdf) or compatible, plain text (.txt), or hypertext markup language (.html/.htm).
 - (f) Test results shall include the following:
 - (1) Telecommunications Room number
 - (2) Location of fiber pull i.e. (Equipment Room # to Telecom Room #)
 - (3) Patch panel # and location
 - (4) Connector type
 - (5) Distance
 - (6) Wavelength tested
 - (7) Technician who performed the testing
- 7) The Owner and Architect reserve the right to observe testing and/or randomly sample completed links for conformance to project specifications.

3.07 COPPER CABLE TESTING AND DOCUMENTATION

- A. Cabling systems shall meet or exceed the electrical and transmission characteristics of the systems specified.
- B. Cable segments and links shall be tested from both ends of the cable for each of the construction phases. (Verify that cable labeling matches at both ends).
- C. The system shall not be considered certified until the tester has acknowledged that the performance of the physical layer of the system has been fully tested and is operational at the completion of the installation phase.
- D. After the installation is complete, in addition to any other required testing as described herein, and at such times as the Owner or Architect directs, the Contractor shall be present while the

Owner conducts an operating test for approval. The installation shall be demonstrated to be in accordance with the requirements of this specification. Any defects revealed shall be corrected promptly at the Contractor's expense and the tests performed again.

- E. After review of the completed test results, the Owner reserves the right to retest the installed cables, utilizing the Contractor's tester and the Contractor's labor.
- F. Equipment Manufacturer's Factory Test
 - 1. Each cable and equipment manufacturer shall factory test their respective products being installed on this project and provide test reports at time of delivery. Provide separate respective test reports indicating that they meet or exceed the latest applicable TIA/EIA Standards and technical bulletins.
 - 2. All other products relative to this specification shall be tested to its respective industry strictest standards.
 - 3. Each manufacturer shall factory test their respective cable or equipment provided to this project at several lower frequency levels, including the minimum and maximum frequency level indicated herein. The test reports shall indicate test results for at least five equal incremental frequency levels including the maximum required.
 - a. Field Testing Equipment: Submit during shop drawing review on the testing equipment to be utilized on this project. Tester shall be a Level IV device or better and configured to the specific cable installed. The installer shall test all cables installed under this Section.
 - 1) Unshielded Twisted Pair Testing Equipment:
 - (a) The cable tester shall have a wide variety of preprogrammed cable types as an integral part of its testing system and have the ability to test cables less than 6 feet (6ft.) from the test point.
 - (1) Testing shall be accomplished using level III or higher field tester that is loaded with the most current version of test software by the manufacturer of the test equipment.
 - (2) Provide factory calibration report of field test equipment.
 - 2) Testing Procedures:
 - (a) Testing shall conform to TIA-568 standards.
 - (b) Testing shall be to the Permanent Link Test Parameters.
 - (c) Test each pair and shield of each cable for opens, shorts, grounds, and pair reversal. Correct grounded and reversed pairs. Examine open and shorted pairs to determine if problem is caused by improper termination. If termination is proper, tag bad pairs at both ends and note on termination sheets.
 - (d) Test each UTP cable and passive components. Provide certification that entire installation of UTP cabling, equipment and jacks are NRTL certified meeting or exceeding a minimum of category performance specified on all four pairs of conductors.
 - (e) Tests shall be based on each pair of conductors and not the aggregate multiple pair results.
 - (f) Test all installed cable segments end-to-end, from the telecommunications room horizontal patch panel/cross connect block panel to each work area outlet and from each telecommunications room backbone patch panel/cross-connect block panel to respective main cross connect, and from the work area outlet to the main cross-connect (through patch cables or cross- connect wiring) with a Signal Injector, Graphical Link Testing Meter and Time Domain Reflectometer (TDR) for compliance to latest TIA performance requirements, as well as NEXT, ELFEXT, structural return

- loss, alternating power sum, opens, shorts, continuity, cable length, and characteristic impedance.
- (g) Provide report indicating failures and what actions were taken to ensure a passing horizontal cable and its terminations. Any cable failing the certification test (Fail, Fail* or, Pass*) must have remedial work done to provide a full pass test result; Remediation may include re-termination or replacement of the cable, which fails. Cables passing within tolerance only (Conditional Pass*) will not be accepted.
- 3) Test results:
- (a) The test results information for each link shall be recorded in the memory of the field tester upon completion of the test. The tester shall be capable of storing test data in either internal or external memory. The external media used shall be left to the discretion of the user.
 - (b) Test results saved by the tester shall be transferred into a Windows based database utility that allows for maintenance, inspection and archiving of these test records. A guarantee must be made that the measurement results are transferred to the PC unaltered as well as any printed reports generated from the software application.
 - (c) Optional formats of data reporting are: comma separated variable (.csv), Portable Document File (.pdf) or compatible, plain text (.txt), or hypertext markup language (.html/.htm).
 - (d) Test Results shall include the following:
 - (1) Applicable room number of jack location (room number per Contract Documents)
 - (2) Applicable Telecommunications Room number
 - (3) Circuit I.D. number with corresponding jack identifier
 - (4) Wire Map - shall include the following:
 - (5) Continuity to the remote end
 - (6) Shorts between any two or more conductors
 - (7) Crossed pairs
 - (8) Reversed pairs
 - (9) Split pairs
 - (10) Any other mis-wiring
 - (11) Length
 - (12) Insertion Loss
 - (13) Near-end Crosstalk (NEXT) Loss
 - (14) PS-NEXT (Power Sum Near End Cross Talk)
 - (15) ELFEXT (Equal Level Far End Cross Talk)
 - (16) PS-ELFEXT (Power Sum Equal Level Far End Cross Talk)
 - (17) Propagation Delay
 - (18) Delay Skew
 - (19) Return loss

3.08 TRAINING AND PATCHING

- A. The Contractor shall provide a minimum of (1) person for a minimum of (8) man-hours beginning with the first scheduled move-in date to train Owner personnel in maintenance and repair of cabling system. This technician shall also assist the Owner in patching telecom services throughout the facility during the move-in period. It is at this time that all Owner-provided connectivity for voice and data services will be provided to the Contractor. Patching of the station assignments between the Owner's services demark shall also be considered part of this Contractor's work.

3.09 ACCEPTANCE

- A. Prior to acceptance all the following conditions must be met:
1. As required the Contractor shall make submittals and deficiencies or rejected submittals shall be corrected.
 2. All specified cable management devices including cable ladder, steel wire cable tray, 2-sided vertical rack cabling sections, horizontal ring panels, and fiber optic troughs shall be installed as indicated and specified. All parts not installed shall be inventoried and provided to the Owner in the manufacturer's packaging.
 3. All seismic bracing shall be in place.
 4. All specified station cabling with associated termination components, labeling and fire stopping shall be installed properly. Any component not installed shall be inventoried and provided to the Owner in the manufacturer's packaging; loose miscellaneous parts shall not be accepted.
 5. Terminal blocks shall be clean and free of trimmed or cut-off copper pairs, sheaths, armors, cable lubricants or any other disposables used in the installation of the station cables.
 6. All station cables shall be neatly dressed behind the terminal blocks in the IDF.
 7. The backbone fiber optic cable system including all strands, connectors, termination shelves, fiber optic distribution panels, and fiber optic storage shelves has been installed and tested per these Specifications.
 8. Do not install fiber optic cross-connects until after the backbone distribution cable test reports have been reviewed and accepted by the Owner.
 9. All required submittals indicated in this Specification Section shall be made by the Contractor, and any deficiencies or rejected submittals shall be corrected.
 10. All specified fiber optic backbone cabling with associated termination components, splicing, labeling and testing shall be installed and completed properly. Any component not installed shall be inventoried and provided to the Owner in the manufacturer's packaging. Loose miscellaneous parts shall not be accepted.
 11. The fiber optic termination shelves and the racks and floors around the shelves, shall be clean and free of trimmed or cut-off fiber optic strands, buffering, sheath and cable lubricants and any other disposables used in the placement and termination of the fiber optic backbone cables.
 12. All innerducts and fiber optic backbone cables shall be neatly dressed into the pathways, communications vaults and vault racking.
 13. Any deficiencies and punch list items shall be corrected.
 14. All as-built documentation shall be complete, reviewed and provided to the Owner.
- B. Acceptance of the telecommunications system by the Owner shall be based on the result of testing, functionality, and the receipt of documentation and warranty. With regard to testing, Contractor shall provide two technicians, equipped with the specified test equipment, to do random test verification in the presence of, and at the direction of, an Owner designated representative. Verification testing shall not exceed 20% of the cable plant, provided cables tested are verified to be 100% compliant, per requirements previously stated. If more than 5% of cables tested during the verification process fail, Owner reserves the right to have the entire cable plant retested, at the Contractor's expense, and in the presence of an Owner-designated representative.

3.10 RECORD DRAWINGS

- A. The project record drawings shall show the types, locations and counts of installed:
1. Fiber optic cables and strands;
 2. Fiber optic terminations counts and types.

- B. The project record drawings shall show the types, locations, cable numbers and pair counts of installed twisted-pair cable:
 - 1. Cable routing and numbers.
- C. The project record drawings shall show the types and locations of installed equipment racks.

END OF SECTION

**SECTION 28 3100
FIRE ALARM SYSTEM - VOICE EVAC**

PART 1 - GENERAL

1.01 DESCRIPTION

- A. This project shall include the furnishing, installation, connection, programming, commissioning, and testing of new fire alarm equipment required to form a complete coordinated system ready for operation at the stadium area. It shall include, but not be limited to, alarm initiating devices, alarm notification appliances, voice evacuation system, , auxiliary control devices, and all associated wiring.
- B. The system shall include an emergency voice evacuation alarm communication system. A digitized pre recorded voice message shall notify occupants that a fire alarm condition has been reported. The message shall instruct the occupants with emergency instructions. All notification shall be speaker/strobes or strobe lights.
- C. The work shall include all required programming to allow proper sequence and operation as required by code.
- D. Provide CBC 2016 compliant seismic installation. See Section 26 0500 for all certification and submittal requirements.
- E. All work shall comply with Sections 26 0500 and 26 2700.

1.02 SCOPE

- A. This specification outlines the requirements for a microprocessor based, addressable (intelligent) automatic fire detection and alarm system. The system and components shall be supplied by one manufacturer.
- B. The work described in this specification consists of all labor, materials, equipment and services necessary and required to complete and test the automatic fire detection and alarm system. Any material not specifically mentioned in this specification or not shown on drawings but required for proper performance and operation shall be furnished, installed, and connected complete.

1.03 REQUIREMENTS

- A. This installation shall be made in accordance with the drawings, specification and the following:
 - 1. National Electrical Code Article 760
 - 2. NFPA Standard 72
 - 3. Local Codes and Authorities Having Jurisdiction
 - 4. ADA requirements and regulations.

1.04 RELATED WORK

- A. Division 26: Basic Electrical Materials and Methods

1.05 FIRE DETECTION SYSTEM DESCRIPTION

- A. The system shall be a networkable, supervised, non-coded, 24 volt DC, power limited system and shall be capable of having all addressable initiation devices on the network in alarm at one time. Notification device circuits shall be wired Class B. Initiation device circuits shall be wired Class A. A single ground or open on any initiating device circuit or notification appliance circuit shall not cause system malfunction, loss of operating power, or the ability to report an alarm.
- B. Provide initiation, notification and other devices as per specifications and as indicated on the drawings.

- C. Indicate alarms, supervisory, and trouble signals on the building fire alarm control panel and annunciator.
- D. Initiate signals to control (shut-off) HVAC system units and FSD's as per drawings and as required by code.
- E. Transmit alarm signals to off-site reporting agency via a digital communicator with specific building address ID.
- F. The fire alarm system shall function as follows when any smoke or duct detector, waterflow switch, manual station or other initiating device operates:
 - 1. Operate required audible/visual and visual devices as shown on the Drawings.
 - 2. Automatically notify off-site reporting agency.
 - 3. Indicate at the control panel alphanumeric display the number and location of the alarmed device.
 - 4. Light an indicating lamp on the smoke detector initiating the alarm.
 - 5. Light an indicating lamp on the remote annunciator indicating the location alarmed as well as the type of device alarmed (area smoke detector, duct detector, manual pull station, waterflow switch, valve supervisory switch, etc.).
 - 6. Perform other actions as per the sequence of operation specified on the fire alarm drawings (i.e. for fire smoke dampers, and other items).
- G. Provide additional system features and capacities as indicated in Part 2 of this Section of the Specifications.

1.06 GUARANTEE

- A. All work performed and all material and equipment furnished under this contract shall be free from defects and shall remain so for a period of at least one (1) year from the date of acceptance.

1.07 APPLICABLE PUBLICATIONS

- A. The publications listed below form a part of this specification.
- B. National Fire Protection Association (NFPA) - USA:
 - 1. No. 70 National Electrical Code (NEC)
 - 2. No. 72 National Fire Alarm Code
 - 3. No. 101 Life Safety Code
- C. Underwriters Laboratories Inc. (UL) - USA:
 - 1. No. 268 Smoke Detectors for Fire Protective Signaling Systems
 - 2. No. 864 Control Units for Fire Protective Signaling Systems
 - 3. No. 268A Smoke Detectors for Duct Applications
 - 4. No. 521 Heat Detectors for Fire Protective Signaling Systems
 - 5. No. 464 Audible Signaling Appliances
 - 6. No. 1971 Visual Signaling Appliances
 - 7. No. 38 Manually Actuated Signaling Boxes
 - 8. No. 346 Waterflow Indicators for Fire Protective Signaling Systems
- D. Local and State Building Codes.
- E. All requirements of the Authority Having Jurisdiction (AHJ).

1.08 APPROVALS

- A. The control panel and all peripherals shall have proper listing and/or approval from Underwriters Laboratory (UL) and be California State Fire Marshall listed and approved.

PART 2 - PRODUCTS

2.01 EQUIPMENT AND MATERIAL, GENERAL

- A. All equipment and components shall be new, and the manufacturer's current model.
- B. The system shall be UL 864 listed.
- C. Acceptable System Manufacturers: Notifier (to match campus standard).
- D. All equipment and components shall be installed in strict compliance with manufacturers' recommendations.
- E. All equipment shall be attached to and ceiling/floor assemblies and shall be held firmly in place. (e.g., detectors shall not be supported solely by suspended ceilings). Fasteners and supports shall be adequate to support the required load.

2.02 CONDUIT, BOXES, AND WIRE

- A. All conduit and wire shall comply with Section 26 0500 of these specifications.
- B. Conduit:
 - 1. Conduit shall be in accordance with The National Electrical Code (NEC), local and state requirements.
 - 2. Conduit fill shall not exceed 40 percent of interior cross sectional area where three or more cables are contained within a single conduit.
 - 3. Cable must be separated from any open conductors of Power, or Class 1 circuits, and shall not be placed in any conduit, junction box or raceway containing these conductors, as per NEC Article 760-29.
 - 4. Conduit shall be 3/4 inch minimum.
- C. Wire:
 - 1. All fire alarm system wiring shall be new and installed in conduit.
 - 2. Wiring shall be in accordance with local, state and national codes (e.g., NEC Article 760). Number and size of conductors shall be as recommended by the fire alarm system manufacturer, but not less than 16 AWG for initiating device circuits and signaling line circuits, and 12 AWG for Notification device circuits.
 - 3. All field wiring shall be completely supervised, Class A for initiation loops, and Class B for notification loops, with end-of-line devices located as shown on the riser diagram.
 - 4. All Class A loops shall include a return cable to the fire alarm panel terminals, per Class A and manufacturer's wiring requirements.
- D. Terminal Boxes, Junction Boxes and Cabinets:
 - 1. All boxes and cabinets shall be UL listed for their use and purpose.
 - 2. The Fire Alarm Control Panel and expander panel shall be connected to a separate dedicated branch circuit, maximum 20 amperes. This circuit shall be labeled at the power panel as FIRE ALARM and include a breaker handle lock for the dedicated breaker. Fire alarm control panel primary power wiring shall be #12 AWG. The control panel cabinet shall be properly grounded.
 - 3. The elevator shunt-trip circuit shall be a dedicated 20 amperes branch circuit. This circuit shall also be labeled at the power panel as FIRE ALARM ELEVATOR SHUNT TRIP and include a breaker handle lock for the dedicated breaker.

2.03 CONTROL PANEL

- A. The control panel shall be designed to monitor and process a minimum of 198 addressable inputs (smoke detectors, manual stations, water flow devices, etc.), and up to 198 addressable monitor or control modules. The Network Communication Lines shall support various annunciation devices (i.e. LED Annunciators, Alphanumeric Displays, Printers) in addition to the addressable inputs and outputs described above. The system architecture shall allow for

T-tapping of the Network Communications Lines. The use of a Zone Monitor module on the Communications Line shall further enhance the system with a master/slave concept, of allowing a group of conventional detection devices (standard smoke detectors, manual stations, waterflow and tamper switches) to be interfaced into the system as an address point. The system shall include individual power supply expander panels as required to support the notification loops. Each notification circuit shall be independently field programmable by the use of addressable control modules rated for the required current.

- B. The control panel shall contain an Alphanumeric Display interface which contains a microprocessor with a non-volatile memory to store field programmable alarm and trouble messages. The Alphanumeric Display shall consist of two 40 character lines for alarm, supervisory and trouble identification, and in quiescent mode, indicates system status.
- C. The control panel shall have history reporting, with the history stored in either the alphanumeric or printer modules. The history shall be at least 1,000 events. These events can be alarm, verification, supervisory, trouble, acknowledge, system reset, walk test, and the use of any panel keypad keys and access to any panel modes such as Program or Test.
- D. The control panel shall have self diagnosis. Once the program is stored in memory and upon system initiating, if there is a discrepancy between the number of devices entered into the program and the actual number of devices connected to the system, the panel shall annunciate a trouble for the devices in question.
- E. Power Supply
 - 1. The Power Supply for the Fire Alarm Control Panel may be integral or external to the Fire Alarm Control Panel, and shall provide all control panel and peripheral device power needs. Additional power required to operate all alarm devices (above and beyond the capacity of the main panel supply) shall be provided with power expander panel(s), connected to the alarm output of the main control panel. Provide all required interface modules and relays for proper notification circuit operation as per manufacturer's instructions. Expander panel shall be as manufactured by the chosen Fire Alarm System manufacturer (qty. as required for full alarm operation).
 - 2. Input power shall be provided at 120 VAC, 60 HZ. The power supply shall provide an integral battery charger for use with a minimum of 12 AH batteries.
 - 3. It shall provide a minimum of 6.0 amperes of regulated 24 VDC power for Audio-Visual alarm notification devices, 200 mA of 4-wire smoke detector power, and 200 mA of Non-Resettable power.
 - 4. The power supply shall be designed to meet UL and NFPA requirements for power-limited operation on all initiating and notification circuits.
 - 5. Positive-temperature-coefficient thermistors, circuit breakers, fuses, or other over-current protection shall be provided on all power outputs.
- F. Mechanical Design: The control panel shall be housed in a cabinet designed for mounting directly to a wall or vertical surface. The back box and door shall be constructed of .060 steel with provisions for electrical conduit connections into the sides and top. No conduit penetrations shall be utilized on the back or bottom of the panel. The door shall provide a key lock and shall include a glass or other transparent opening for viewing of all indicators. The cabinet shall be approximately 5 inches deep and 14.5 inches wide. Height shall be approximately 16 inches.

2.04 STANDARD INITIATION DEVICES

- A. Addressable Photoelectric Smoke detectors, (Intelligent) shall be provided as indicated on the drawings, with features and characteristics as follows:
 - 1. The detector shall be self compensating for ambient temperature and humidity.

2. The detector shall be addressed, tested and programmed prior to installation using a UL listed programmer/tester. The detector readout shall yield a discrete electrical value for status tracking and logging for determining maintenance and cleaning requirements.
 3. The detector shall be suitable for two wire operation and two way communication on the intelligent analog signaling circuits.
 4. The detector shall display a flashing red LED when in the alarm state when the system is operating from normal or standby power.
 5. The detectors furnished shall be listed for use in environments as covered by Factory Mutual, UL and shall be installed according to the requirements of NFPA 72 for open area coverage.
 6. Detectors for magnetic door hold open functions shall be provided with an auxiliary relay base for auxiliary function wiring connections.
 - a. Door holder power shall be routed via the relay base on smoke detectors denoted with an "R" to release the associated doors upon alarm.
- B. Heat detectors shall be provided as indicated on drawings. Heat detector shall be of the rate compensation type, 135 degree.
- C. Manual Stations, (Intelligent) shall be single action and semi-flush or surface mounted as indicated on the drawings.
 1. The manual station shall be equipped with terminal strip and pressure style screw terminals for the connection of field wiring.
 2. The manual stations shall be addressable and identifiable by the master fire alarm control panel when they are resident on the analog loop. Address programming shall be accomplished electronically and reside within the station in non volatile memory.
- D. A monitor module Interface device shall be provided for required interface points such as water flow devices and tamper switches, or any contact type devices as indicated on drawings. This Interface device shall have one or two Class B (Style 4) circuits as required.
- E. Provide a 120VAC circuit connection to each sprinkler system water flow bell (provided by Div. 15). Wire power via the local water flow switch aux. Contact to activate the bell upon water flow activation.

2.05 BATTERIES

- A. Batteries shall be 12 volt, sealed valve-regulated type, with combined Amp-Hour ratings as required by code.
- B. Battery shall have a minimum sufficient capacity to power the fire alarm system for not less than twenty-four hours in standby mode, plus 5 minutes of full system alarm upon a normal AC power failure.
- C. The batteries are to be completely maintenance free, no liquids required. Fluid level checks, refilling, spills and leakage shall not be required.

2.06 CONTROL DEVICES

- A. Control modules shall be provided as indicated on the drawings for fire alarm output functions. These devices shall be connected to the Network Communications Lines, and be field programmable for one of the following options; Remote Relay (form C 1amp 24vdc, 200ma 120vac) with supervised relay operation, Remote Supervised Indicating Appliance Circuit (fused at 1 amp). There shall be an LED on the device that will flash to indicate the unit is being monitored and a steady LED to indicate the unit has been activated. Secondary relays with control power connections shall be provided as required where contact ratings (voltage & amps) so dictate.

2.07 NOTIFICATION DEVICES

- A. Speaker / Strobe Notification Devices:
1. All speakers shall operate on 70.7 VRMS, with field selectable output taps from 1/8 to 2 Watts in 3dB steps. Frequency response shall be a minimum of 400 HZ to 4 KHZ.
 - a. Speaker circuits shall have 20% spare capacity for future expansion or increased power output requirements. All speaker tap settings shall be set per recommended settings (minimum 1/4 watt) for area coverage, and shall be re-tapped as required after final testing to provide adequate audible coverage throughout each area (to meet NFPA requirements).
 - b. Speaker circuits and control equipment shall be arranged such that loss of any one (1) speaker circuit will not cause the loss of any other speaker circuit in the system.
 - c. Provide amplifier modules as required to carry the full designed load, plus 20% spare capacity. Provide (1) additional back-up amplifier module for automatic back up of any failed amplifier module.
 - d. Speaker/Strobe combinations shall be provided as indicated on Drawings. The speaker / strobe combination shall be Wheelock or equal, ADA and UL 1971 compliant (candela values as required) - white finish.
 - e. Strobe Lights shall be provided as indicated on Drawings. The strobe lights shall be wall mounted at +80" AFF or 6" below the ceiling level, whichever is lower, Wheelock or equal, ADA and UL 1971 compliant (candela values as required) - white finish
- B. Refer to Part 3 of this Section for required synchronization of strobes when located in the same field of view.

2.08 AUDIO AMPLIFIERS

- A. The Audio Amplifiers shall provide audio power at 70.7 Volts RMS for distribution to speaker circuits.
- B. Multiple audio amplifiers shall be mounted in the FACP, or at the FACP or expander panel locations, either to supply incremental audio power, or to function as an automatically switched backup amplifier(s).
- C. The audio amplifiers shall include an integral power supply, and shall provide the following controls and indicators:
1. Normal Audio Level LED
 2. Incorrect Audio Level LED
 3. Brownout LED
 4. Battery Trouble LED
 5. Amplifier Trouble LED

2.09 AUDIO AMPLIFIER GAIN ADJUST

- A. Adjustment of the correct audio level for the amplifier shall not require any special tools or test equipment.
- B. Amplifiers shall include audio input and amplified output supervision; back up input, and automatic switch over function, (if primary amplifier should fail).
- C. Amplifiers shall be backed up in groups (1 amplifier backs up several at the same location). Failure of any one amplifier in the system shall not degrade system performance in any way

2.10 AUDIO MESSAGE GENERATOR (PRERECORDED VOICE)

- A. Each initiating zone or intelligent device shall interface with an emergency voice communication system capable of transmitting a prerecorded voice message to all speakers in the building.

- B. Activation of any alarm-initiating device shall cause a prerecorded message to sound over the designated speakers. The message shall be repeated a minimum of four (4) times.
- C. A built in microphone shall be provided to allow paging through speaker zone circuits.
- D. The audio message generator shall have the following controls and indicators to allow for proper operator understanding and control:
 - 1. All Call LED
 - 2. On Line LED
- E. All Call Switch Local Speaker Volume Control Local (Test) Speaker

2.11 SPEAKER CIRCUIT CONTROL SWITCHES / INDICATORS

- A. The speaker circuit control switches/indicators shall include visual indication of active and trouble status for each speaker circuit in the system.
- B. The speaker circuit control panel shall include switches to manually activate or deactivate each speaker circuit in the system.

PART 3 - EXECUTION

3.01 INSTALLATION

- A. Installation shall be in accordance with the NEC, NFPA 72, local and state codes, as shown on the drawings, and as recommended by the major equipment manufacturer.
- B. All conduit, junction boxes, conduit supports and hangers shall be concealed in finished areas and may be exposed in unfinished areas. Smoke detectors shall not be installed prior to the system programming and test period. If construction is ongoing during this period, measures shall be taken to protect smoke detectors from contamination and physical damage.
- C. All fire detection and alarm system devices, control panel and remote annunciator shall be flush mounted when located in finished areas and may be surface mounted when located in unfinished areas.
- D. Provide identification labeling on all devices to identify loop and device number/address. Labeling shall consist of min. 3/8" black lettering on white background P-Touch style adhesive labels with machine printing, Helvetica font or similar.
- E. At the final inspection a factory trained representative of the manufacturer of the major equipment shall perform the tests in Section 3.2 TESTING.
- F. Wiring:
 - 1. All circuits shall be in conduit, minimum 3/4".
 - a. Addressable loops circuits shall be two (2) conductor twisted/shielded or wiring approved by the manufacturer.
 - 1) Speaker audio circuits shall be two (2) #16 conductor (twisted/shielded) or wiring approved by the manufacturer.
 - 2) Notification circuits shall be 12 AWG minimum for strobes, but not to exceed manufacturers wire capacity for modules. Control power circuits shall be 14 AWG minimum or as required.
 - 3) Network communications loop shall be a 50/125 micron multi-mode fiber optic outside plant cable installed in inner-duct in the fire alarm site conduit.
 - 4) Network cabling and interface cabling from the fire alarm system to the VESDA detection network shall be as indicated on the drawings or as approved by the manufacturer.
 - 5) When (3) or more visual notification devices are located within the same field of view and are less than 55 feet apart (within the field of view), all devices within that field of view shall be synchronized to provide the same flash rate and

frequency. Provide all required sync modules and compatible strobe devices to provide a synchronized output.

3.02 TESTING

- A. Provide the service of a competent, factory trained engineer or technician authorized by the manufacturer of the fire alarm equipment to technically supervise and participate during all of the adjustments and tests for the system. Each building shall be separately tested as completed and the entire networked system tested just prior to project completion. Include contractor pre-test for each building prior to the final AHJ testing to insure a suitable final test result.
1. Before energizing the cables and wires, check for correct connections and test for short circuits, ground faults, continuity, and insulation.
 2. Close each sprinkler system flow valve and verify proper supervisory alarm at the FACP and annunciator.
 3. Verify activation of all flow switches.
 4. Open initiating device circuits and verify that the trouble signal actuates at the FACP and annunciator.
 5. Open and short all notification appliance circuits and verify that trouble signals actuate at the FACP and annunciator.
 6. Ground circuits and verify response of trouble signals at the FACP and annunciator.
 7. Check presence and audibility of voice evacuation message at all speaker/strobe devices.
 8. Check installation, supervision, and operation.
 9. Verify that each initiating device alarm is properly received and processed by the FACP and annunciator (Walk Test).
 10. Conduct tests from FACP to verify trouble indications for common mode failures, such as alternating current power failure.
- B. Test reports shall include, but not be limited to:
1. A complete list of equipment installed indicating proper operations as listed above.

3.03 FINAL INSPECTION

- A. Final acceptance will require the contractor to deliver to the Owner the following:
1. Three (3) copies of the operating instructions and system maintenance manuals.
 2. Three (3) set of record drawings.
 3. Three (3) copies of the final test reports.
 4. Three (3) copies indicating the name and phone number of person to contact in the event of equipment failure, and date when system warranty will be terminate.
 5. Three (3) sets of data sheets for each piece of equipment supplied.
- B. The fire alarm system subcontractor or manufacturer shall offer for the Owner's consideration at the time of system submittal a priced inspection, maintenance, testing and repair contract in full compliance with the requirements of NFPA 72.
1. The services offered under this contract shall be performed at no charge during the first year after system acceptance and the owner shall have the option of renewing for single or multiple years, up to five years, at the price quoted in bid.
 2. The contractor performing the contract services shall be qualified and listed to maintain ongoing certification of the completed system to the UL for specific installed system listing.

3.04 GUARANTEE

- A. The fire detection system shall be guaranteed for a period of one year from date of acceptance. The guarantee shall cover parts, labor, and travel to and from the site.

3.05 INSTRUCTION

- A. Provide complete instruction manuals and training to the building personnel. "Hands-on" demonstrations of the operation of all system components and the entire system shall be provided.

END OF SECTION



O'MAHONY & MYER
ELECTRICAL ENGINEERING & LIGHTING DESIGN

**LIBERTY HIGH SCHOOL
STADIUM IMPROVEMENTS
PROJECT**

**FIRE ALARM MANUFACTURER
CUT SHEETS AND CSFM LISTINGS**

(The manufacturer cut sheets and CSFM listings in this document are the specified equipment and devices of the fire alarm system for DSA review)

4340 Redwood Hwy., Suite 245 San Rafael, CA 94903
TEL 415-492-0420 FAX 415-479-9662

FIRE ALARM EQUIPMENT LIST

| SYMBOL | DESCRIPTION | MANUFACTURER & MODEL NUMBER | CSFM LISTING NUMBER | STANDBY CURRENT | ALARM CURRENT |
|------------------|---|--|---------------------|-----------------|---------------|
| | FIRE ALARM CONTROL PANEL WITH INTEGRAL UDACT | NOTIFIER NFS-320 | 7165-0028:0243 | 290mA | 650mA |
| | FIRE ALARM EXPANDER PANEL | NOTIFIER ACPS-610 W/ CAB-PS1 CABINET | 7315-0028:0248 | 150mA | 90mA |
| | VOICE COMMAND WITH LOCAL MICROPHONE, 70V XFMR, MISC MODULES FOR ADDITIONAL SPEAKER CIRCUITS, ETC. | NOTIFIER NFC-50/100 NFC-BDA-25/70V NFC-CE6 | 6911-0028:0265 | 372mA | 681mA |
| | DIGITAL CELLULAR ALARM COMMUNICATOR | HONEYWELL IPGSM-4G | 7300-1645:0199 | 230mA | 950mA |
| | ADDRESSABLE MANUAL PULL STATION | NOTIFIER NBG-12LX | 7150-0028:0199 | 0.38mA | 5.10mA |
| | ADDRESSABLE MONITOR MODULE | NOTIFIER FMM-1 | 7300-0028:0219 | 0.38mA | 5.10mA |
| | ADDRESSABLE CONTROL MODULE | NOTIFIER FCM-1 | 7300-0028:0219 | 0.35mA | 6.50mA |
| | ADDRESSABLE PHOTOELECTRIC SMOKE DETECTOR | NOTIFIER FSP-851 | 7272-0028:0206 | 0.36mA | 6.50mA |
| | ADDRESSABLE FIXED TEMPERATURE HEAT DETECTOR (135F) | NOTIFIER FST-851 | 7270-0028:0196 | 0.36mA | 6.50mA |
| | VISUAL STROBE, CEILING MOUNT, SELECTABLE CANDELA UL 1971 PUBLIC MODE NOTIFICATION | WHEELock STC | 7125-0785:0168 | - | - |
| 15cd | | | 0mA | 57mA | |
| 30cd | | | 0mA | 85mA | |
| 75cd | | | 0mA | 135mA | |
| 110cd | | | 0mA | 182mA | |
| | COMBINATION VISUAL STROBE AND SPEAKER (1W), WALL MOUNT, SELECTABLE CANDELA UL 1971 PUBLIC MODE NOTIFICATION, VISUAL DEVICE | WHEELock #E70H-24MCW-FR (1/4 WATT TAP) | 7125-0785:0173 | - | - |
| STROBE CKT: 15cd | | | 0mA | 60mA | |
| STROBE CKT: 30cd | | | 0mA | 92mA | |
| STROBE CKT: 75cd | | | 0mA | 165mA | |
| | COMBINATION VISUAL STROBE AND SPEAKER (1W), CEILING MOUNT, SELECTABLE CANDELA UL 1971 PUBLIC MODE NOTIFICATION, VISUAL DEVICE | WHEELock #E90H-24MCC-FR (1/4 WATT TAP) | 7125-0785:0173 | - | - |
| STROBE CKT: 15cd | | | 0mA | 65mA | |
| STROBE CKT: 30cd | | | 0mA | 105mA | |
| STROBE CKT: 75cd | | | 0mA | 189mA | |
| | EXTERIOR AUDIBLE SPEAKER (1W) WITH WEATHER-PROOF FLUSH BACKBOX | WHEELock #ET-1010R | 7125-0785:0105 | 0mA | 7mA |
| | | | | | |
| | DOCUMENTATION CABINET | SPACE AGE ACE-11 | 7300-0553:0110 | - | - |

NOTE:

DETECTOR SUBSCRIPTS:

"c" - DETECTOR IN ACCESSIBLE CEILING SPACE

"p" - DETECTOR WITHIN 36" OF PEAK

NFS-320

Intelligent Addressable Fire Alarm System



Intelligent Fire Alarm Control Panels

General

The NFS-320 intelligent Fire Alarm Control Panel is part of the ONYX® Series of Fire Alarm Controls from NOTIFIER.

In stand-alone or network configurations, ONYX Series products meet virtually every application requirement.

The NFS-320's modular design makes system planning easier. The panel can be configured with just a few devices for small building applications, or networked with many devices to protect a large campus or a high-rise office block. Simply add additional peripheral equipment to suit the application. Wireless fire protection can be added with the SWIFT wireless gateway and devices.

For installations using NFS-320C, an optional ACM Series annunciator can be mounted in the same cabinet (up to 48 zones/points, order separately; see DN-60085).

NOTE: Unless called out with a version-specific "R", "C" or "E" at the end of the part number, "NFS-320" refers to models NFS-320, NFS-320R, NFS-320C, and NFS-320E.

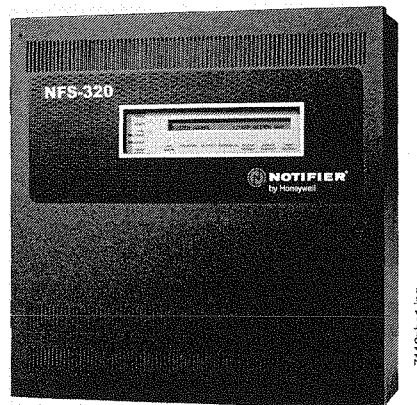

NFS-320

Features

- Certified for seismic applications when used with the appropriate seismic mounting kit.
- Approved for Marine applications when used with listed compatible equipment. See DN-60688.
- One isolated intelligent Signaling Line Circuit (SLC) Style 4, 6 or 7.
- Up to 159 detectors and 159 modules per SLC; 318 devices maximum.
 - Detectors can be any mix of ion, photo, thermal, or multi-sensor; wireless detectors are available for use with the FWSG.
 - Modules include addressable pull stations, normally open contact devices, two-wire smoke detectors, notification, or relay; wireless modules are available for use with the FWSG.
- Optional FWSG Wireless SWIFT Gateway supports wireless SLC devices.
- Standard 80-character display.
- Network options:
 - High-speed network for up to 200 nodes (NFS2-3030, NFS2-640, NFS-320(C), NFS-320SYS, NCA-2, DVC-EM, ONYX-Works, NFS-3030, NFS-640, and NCA).
 - Standard network for up to 103 nodes (NFS2-3030, NFS2-640, NFS-320(C), NFS-320SYS, NCA-2, DVC-EM, ONYX-Works, NCS, NFS-3030, NFS-640, NCA, AFP-200, AFP-300/400, AFP-1010, and AM2020). Up to 54 nodes when DVC-EM is used in network paging.
- 6.0 A power supply with four Class A/B built-in Notification Appliance Circuits (NAC). Selectable System Sensor, Wheelock, or Gentex strobe synchronization.
- Built-in Alarm, Trouble, Security, and Supervisory relays.
- VeriFire® Tools online or offline programming utility. Upload/Download, save, store, check, compare, and simulate panel databases. Upgrade panel firmware.
- Autoprogramming and Walk Test reports.
- Multiple central station communication options:
 - Standard UDACT
 - Internet
 - Internet/GSM
- 80-character remote annunciators (up to 32).
- EIA-485 annunciators, including custom graphics.
- Printer interface (80-column and 40-column printers).
- History file with 800-event capacity in nonvolatile memory, plus separate 200-event alarm-only file.

- Alarm Verification selection per point, with automatic counter.
- Presignal/Positive Alarm Sequence (PAS).
- Silence inhibit and Auto Silence timer options.
- NAC coding functions:
 - March time.
 - Temporal.
 - California two-stage coding.
 - Canadian two-stage.
 - Strobe synchronization.
- Field-programmable on panel or on PC with VeriFire® Tools program check, compare, simulate.
- Full QWERTY keypad.
- Battery charger supports 18 – 200 AH batteries.
- Non-alarm points for lower priority functions.
- Remote ACK/Signal Silence/System Reset/Drill via monitor modules.
- Automatic time control functions, with holiday exceptions.
- Extensive, built-in transient protection.
- Powerful Boolean logic equations.

FLASHSCAN® INTELLIGENT FEATURES

- Polls up to 318 devices in less than two seconds.
- Activates up to 159 outputs in less than five seconds.
- Multicolor LEDs blink device address during Walk Test.
- Fully digital, high-precision protocol (U.S. Patent 5,539,389).
- Manual sensitivity adjustment — up to nine levels.
- Pre-alarm ONYX intelligent sensing — up to nine levels.
- Day/Night automatic sensitivity adjustment.
- Sensitivity windows:
 - Ion – 0.5 to 2.5%/foot obscuration.
 - Photo – 0.5 to 2.35%/foot obscuration.
 - Laser (VIEW®) – 0.02 to 2.0%/foot obscuration.
 - Acclimate® Plus™ – 0.5 to 4.0%/foot obscuration.
 - IntelliQuad – 1.0 to 4.0%/foot obscuration.
 - IntelliQuad™ PLUS – 1.0 to 4.0%/foot obscuration
- Drift compensation (U.S. Patent 5,764,142).
- Degraded mode — in the unlikely event that the NFS-320's primary microprocessor fails, FlashScan detectors revert to degraded operation and can activate the control panel's NAC circuits and alarm relay. Each of the four built-in panel circuits includes a Disable/Enable switch for this feature.

- Multi-detector algorithm involves nearby detectors in alarm decision (U.S. Patent 5,627,515).
- Automatic detector sensitivity testing (NFPA-72 compliant).
- Maintenance alert (two levels).
- Self-optimizing pre-alarm.

FSL-751 VIEW (VERY INTELLIGENT EARLY WARNING)

SMOKE DETECTION TECHNOLOGY

- Advanced ONYX intelligent sensing algorithms differentiate between smoke and non-smoke signals (U.S. Patent 5,831,524).
- Addressable operation pinpoints the fire location.
- Early warning performance comparable to the best aspiration systems at a fraction of the lifetime cost.

FAPT-851 ACCLIMATE® PLUS™

LOW-PROFILE INTELLIGENT MULTI-SENSOR

- Detector automatically adjusts sensitivity levels without operator intervention or programming. Sensitivity increases with heat.
- Microprocessor-based technology; combination photo and thermal technology.
- Low-temperature warning signal at 40°F ± 5°F (4.44°C ± 2.77°C).

FSC-851 INTELLIQUAD

ADVANCED MULTI-CRITERIA DETECTOR

- Detects all four major elements of a fire (smoke, heat, CO, and flame).
- Automatic drift compensation of smoke sensor and CO cell.
- High nuisance-alarm immunity.

INTELLIGENT FAAST® DETECTORS FSA-5000, FSA-8000, FSA-20000 AND FSA-20000P

- Connects directly to the SLC loop of compatible ONYX series panels.
- Provides five event thresholds that can be individually programmed with descriptive labels for control-by-event programming; uses five detector addresses.

- Uses patented particle separator and field-replaceable filter to remove contaminants.
- Advanced algorithms reject common nuisance conditions
- FSA-5000 covers 5,000 square feet through one pipe.
- FSA-8000 covers 8,000 square feet through one pipe.
- FSA-20000 covers 28,800 square feet through one to four pipes.
- FSA-20000P covers 28,800 square feet through one to four pipes. Supports addressable pipes to pinpoint location of alarm events.

FCO-851 INTELLIQUAD™ PLUS

ADVANCED MULTI-CRITERIA FIRE/CO DETECTOR

- Detects all four major elements of a fire.
- Separate signal for life-safety CO detection.
- Optional addressable sounder base for Temp-3 (fire) or Temp-4(CO) tone.
- Automatic drift compensation of smoke sensor and CO cell.
- High nuisance-alarm immunity.

SWIFT WIRELESS

- Self-healing mesh wireless protocol.
- Each SWIFT Gateway supports up to 50 devices: 1 wireless gateway and up to 49 SWIFT devices.
- Up to 4 wireless gateways can be installed with overlapping network coverage.

RELEASING FEATURES

- Ten independent hazards.
- Sophisticated cross-zone (three options).
- Delay timer and Discharge timers (adjustable).
- Abort (four options).
- Low-pressure CO2 listed.

VOICE FEATURES

- Integrates with FirstCommand Series. See DN-60772.
- Telephone applications require NFC-FFT.

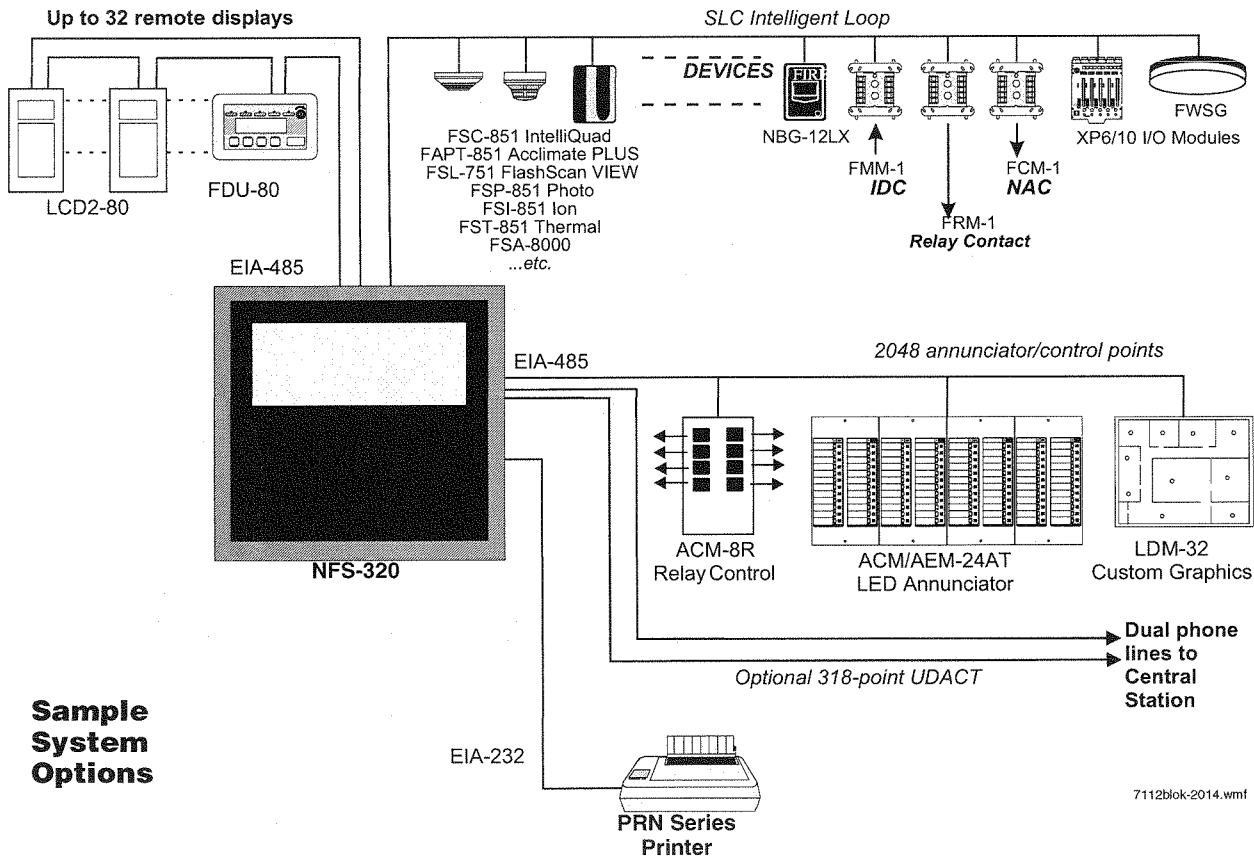

HIGH-EFFICIENCY OFFLINE SWITCHING
3.0 A POWER SUPPLY (6.0 A IN ALARM)

- 120 VAC (NFS-320/NFS-320C); 240 VAC (NFS-320E).
- Displays battery current/voltage on panel (with display).

**FlashScan, Exclusive
World-Leading Detector Protocol**

At the heart of the NFS-320 is a set of detection devices and device protocol — FlashScan (U.S. Patent 5,539,389). FlashScan is an all-digital protocol that gives superior precision and high noise immunity.

In addition to providing quick identification of an active input device, this protocol can also activate many output devices in a fraction of the time required by competitive protocols. This high speed also allows the NFS-320 to have the largest device per loop capacity in the industry — 318 points — yet every input and output device is sampled in less than two seconds. The microprocessor-based FlashScan detectors have bicolor LEDs that can be coded to provide diagnostic information, such as device address during Walk Test.

ONYX Intelligent Sensing

Intelligent sensing is a set of software algorithms that provides the NFS-320 with industry-leading smoke detection capability. These complex algorithms require many calculations on each reading of each detector, and are made possible by the high-speed micro-computer used by the NFS-320.

Drift Compensation and Smoothing: Drift compensation allows the detector to retain its original ability to detect actual smoke, and resist false alarms, even as dirt accumulates. It reduces maintenance requirements by allowing the system to automatically perform the periodic sensitivity measurements required by NFPA 72. Smoothing filters are also provided by software to remove transient noise signals, such as those caused by electrical interference.

Maintenance Warnings: When the drift compensation performed for a detector reaches a certain level, the performance of the detector may be compromised, and special warnings are given. There are three warning levels: (1) Low Chamber value; (2) Maintenance Alert, indicative of dust accumulation that is near but below the allowed limit; (3) Maintenance Urgent, indicative of dust accumulation above the allowed limit.

Sensitivity Adjust: Nine sensitivity levels are provided for alarm detection. These levels can be set manually, or can change automatically between day and night. Nine levels of pre-alarm sensitivity can also be selected, based on predetermined levels of alarm. Pre-alarm operation can be latching or self-restoring, and can be used to activate special control functions.

Self-Optimizing Pre-Alarm: Each detector may be set for “Self-Optimizing” pre-alarm. In this special mode, the detector “learns” its normal environment, measuring the peak analog readings over a long period of time, and setting the pre-alarm level just above these normal peaks.

Cooperating Multi-Detector Sensing: A patented feature of ONYX intelligent sensing is the ability of a smoke sensor to consider readings from nearby sensors in making alarm or pre-alarm decisions. Without statistical sacrifice in the ability to resist false alarms, it allows a sensor to increase its sensitivity to actual smoke by a factor of almost two to one.

Field Programming Options

Autoprogram is a timesaving feature. The FACP “learns” what devices are physically connected and automatically loads them in the program with default values for all parameters. Requiring less than one minute to run, this routine allows the user to have almost immediate fire protection in a new installation, even if only a portion of the detectors are installed.

Keypad Program Edit (with KDM-R2) The NFS-320, like all NOTIFIER intelligent panels, has the exclusive feature of program creation and editing capability from the front panel keypad, while continuing to provide fire protection. The architecture of the NFS-320 software is such that each point entry carries its own program,

including control-by-event links to other points. This allows the program to be entered with independent per-point segments, while the NFS-320 simultaneously monitors other (already installed) points for alarm conditions.

VeriFire® Tools is an offline programming and test utility that can greatly reduce installation programming time, and increase confidence in the site-specific software. It is Windows®-based and provides technologically advanced capabilities to aid the installer. The installer may create the entire program for the NFS-320 in the comfort of the office, test it, store a backup file, then bring it to the site and download from a laptop into the panel.

**Placement of Equipment
in Chassis and Cabinet**

The following guidelines outline the NFS-320's flexible system design.

Wiring: When designing the cabinet layout, consider separation of power-limited and non-power-limited wiring as discussed in the *NFS-320 Installation Manual*.

It is critical that all mounting holes of the NFS-320 are secured with a screw or standoff to ensure continuity of Earth Ground.

Networking: If networking two or more control panels, each unit requires a Network Communication Module or High-Speed Network Communication Module (HS-NCM can support two nodes; see “Networking Options” on page 4). These modules can be installed in any option board position (see manual), and additional option boards can be mounted in front of them.

KDM-R2 Controls and Indicators

Program Keypad: QWERTY type (keyboard layout).

12 LED Indicators: Power; Fire Alarm; Pre-Alarm; Security; Supervisory; System Trouble; Signals Silenced; Points Disabled; Control Active; Abort; Pre-Discharge; Discharge.

Keypad Switch Controls: Acknowledge/Scroll Display; Signal Silence; Drill; System Reset; Lamp Test.

LCD Display: 80 characters (2 x 40) with long-life LED backlight.

Product Line Information

- “Configuration Guidelines” on page 3
- “Networking Options” on page 4
- “Auxiliary Power Supplies and Batteries” on page 4
- “Audio Options” on page 4
- “Compatible Devices, EIA-232 Ports” on page 4
- “Compatible Devices, EIA-485 Ports” on page 4
- “Compatible Intelligent Devices” on page 4
- “Enclosures, Chassis, and Dress Plates” on page 5
- “Other Options” on page 5

CONFIGURATION GUIDELINES

The NFS-320 system ships assembled; description and some options follow. See “Enclosures, Chassis, and Dress Plates” on page 5 for information about mounting peripherals.

NOTE: Stand-alone and network systems require a main display. On stand-alone systems, the panel's keypad provides the required display. On network systems (two or more networked fire panel nodes), at least one NCA-2, NCS, or ONYXWorks annunciation device is required. (For NCA-2, see DN-7047.)

NFS-320: The standard, factory-assembled NFS-320 system includes the following components: one control panel mounted on chassis (120 V operation — ships with grounding cable, battery interconnect cables, and document kit); includes integral power supply mounted to the main circuit board; one primary display KDM-R2 keypad/display; and one cabinet for surface or semi-flush mounting. Purchase batteries separately. One or two option boards may be mounted inside the NFS-320 cabinet; additional option boards can be used in remote cabinets. (Non-English versions also available. NFS-320-SF, NFS-320-PO.)

NFS-320R: Same as NFS-320, but in red enclosure.

NFS-320C: Based on NFS-320 above. NFS-320C supports installation of an optional ACM-series annunciator in the same cabinet. UL- and ULC-listed. (Non-English version also available: NFS-320C-FR.) For NFS-320C, see DN-60085.

NFS-320CR: Same as NFS-320C but in a red enclosure. For NFS-320C, see DN-60085.

NFS-320E: Same as NFS-320, but with 240 V operation. (Non-English versions also available. NFS-320E-SP, NFS-320E-PO.)

TR-320: Trim ring for the NFS-320 cabinet.

NETWORKING OPTIONS

NCM-W, NCM-F: Standard Network Communications Modules. Wire and multi-mode fiber versions available. See DN-6861.

HS-NCM-W/MF/SF/WMF/WSF/MFSF: High-speed Network Communications Modules. Wire, single-mode fiber, multi-mode fiber, and media conversion models are available. See DN-60454.

RPT-W, RPT-F, RPT-WF: Standard-network repeater board with wire connection (RPT-W), multi-mode fiber connection (RPT-F), or allowing a change in media type between wire and fiber (RPT-WF). Not used with high-speed networks. See DN-6971.

ONYXWorks: UL-listed graphics PC workstation, software, and computer hardware. See DN-7048 for specific part numbers.

NFN-GW-EM-3: NFN Gateway, embedded. See DN-60499.

NWS-3: NOTI•FIRE•NET™ Web Server. See DN-6928.

CAP-GW: Common Alerting Protocol Gateway. See DN-60756.

VESDA-HLI-GW: VESDAnet high-level interface gateway. See DN-60753.

LEDSIGN-GW: UL-listed sign gateway. Interfaces with classic and high-speed NOTI•FIRE•NET networks through the NFN Gateway. See DN-60679.

OAX2-24V: UL-listed LED sign, used with LEDSIGN-GW. See DN-60679.

AUXILIARY POWER SUPPLIES AND BATTERIES

ACPS-610: 6.0 A or 10.0 A addressable charging power supply. See DN-60244.

APS2-6R: Auxiliary Power Supply. Provides up to 6.0 amperes of power for peripheral devices. Includes battery input and transfer relay, and overcurrent protection. Mounts on two of four positions on a CHS-4L or CHS-4 chassis. See DN-5952.

FCPS-24S6/S8: Remote 6 A and 8 A power supplies with battery charger. See DN-6927.

BAT Series: Batteries. NFS-320 uses two 12 volt, 18 to 200 AH batteries. See DN-6933.

AUDIO OPTIONS

NFC-50/100: 25 watt, 25 VRMS, emergency Voice Evacuation Control Panel (VECP) with integral commercial microphone, digital message generator, and Class A or Class B speaker circuits. See DN-60772.

COMPATIBLE DEVICES, EIA-232 PORTS

PRN-7: 80-column printer. See DN-60897.

VS4095/5: Printer, 40-column, 24 V. Mounted in external backbox. See DN-3260.

DPI-232: Direct Panel Interface, specialized modem for extending serial data links to remotely located FACPs and/or peripherals; mount on NFS-320 chassis. See DN-6870.

COMPATIBLE DEVICES, EIA-485 PORTS

ACM-24AT: ONYX Series ACS annunciator – up to 96 points of annunciation with Alarm or Active LED, Trouble LED, and switch per circuit. Active/Alarm LEDs can be programmed (by powered-up switch selection) by point to be red, green, or yellow; the Trouble LED is always yellow. See DN-6862.

AEM-24AT: Same LED and switch capabilities as ACM-24AT, expands the ACM-24AT to 48, 72, or 96 points. See DN-6862.

ACM-48A: ONYX Series ACS annunciator – up to 96 points of annunciation with Alarm or Active LED per circuit. Active/Alarm LEDs can be programmed (by powered-up switch selection) in groups of 24 to be red, green, or yellow. Expandable to 96 points with one AEM-48A. See DN-6862.

AEM-48A: Same LED capabilities as ACM-48A, expands the ACM-48A to 96 points. See DN-6862.

ACM-8R: Remote Relay Module with eight Form-C contacts. Can be located up to 6,000 ft. (1828.8 m) from panel on four wires. See DN-3558.

FDU-80: Terminal mode. 80-character, backlit LCD display. Mounts up to 6,000 ft. (1828.8 m) from panel. Up to 32 per FACP. See DN-6820.

LCD2-80: Terminal and ACS mode. 80-character, backlit LCD display. Mounts up to 6,000 ft. (1828.8 m) from panel. Up to 32 per FACP. See DN-60548.

LDM: Lamp Driver Modules LDM-32, LDM-E32, and LDM-R32; remote custom driver modules. See DN-0551.

SCS: Smoke control stations SCS-8, SCE-8, with lamp drivers SCS-8L, SCE-8L; eight (expandable to 16) circuits (HVAC only). See DN-4818.

TM-4: Transmitter Module. Includes three reverse-polarity circuits and one municipal box circuit; mount on NFS-320 chassis or remotely. See DN-6860.

UDACT-2: Universal Digital Alarm Communicator Transmitter, 636 channel. See DN-60686.

UZC-256: Programmable Universal Zone Coder provides positive non-interfering successive zone coding. Microprocessor-controlled, field-programmable from IBM®-compatible PCs (requires optional programming kit). Mounts in BB-UZC. See DN-3404.

COMPATIBLE INTELLIGENT DEVICES

NOTE: "A" suffix indicates ULC-Listed model:

FWSG Wireless SWIFT Gateway: Addressable gateway supports wireless SLC devices. Not appropriate for ULC applications. See DN-60820.

FSA-5000: Intelligent FFAST® XS Fire Alarm Aspiration Sensing Technology. Intelligent aspirating smoke detector for applications up to 5,000 sq.ft. For Canadian applications, order FSA-5000A.

FSA-8000: Intelligent FFAST® XM Fire Alarm Aspiration Sensing Technology. Intelligent aspirating smoke detector for applications up to 8,000 sq.ft. For Canadian applications, order FSA-8000A. See DN-60792

FSA-20000: Intelligent FFAST® XT Fire Alarm Aspiration Sensing Technology. Intelligent aspirating smoke detector for applications up to 28,800 sq.ft. For Canadian applications, order FSA-20000A. See DN-60849.

FSA-20000P FFAST® XT PRO Intelligent Aspiration Detector For applications up to 28,800 sq. ft. (2601 sq. m.) through one to four addressable pipes. See DN-60792

FSB-200(A): Intelligent beam smoke detector. See DN-6985.

FSB-200S(A): Intelligent beam smoke detector with integral sensitivity test. See DN-6985

FSC-851(A): FlashScan IntelliQuad Advanced Multi-Criteria Detector. See DN-60412.

FCO-851(A): FlashScan IntelliQuad PLUS Advanced Multi-Criteria Fire/CO Detector. See DN-60689.

FSI-851(A): Low-profile FlashScan ionization detector. See DN-6934.

FSP-851(A): Low-profile FlashScan photoelectric detector. See DN-6935.

FSP-851T(A): Low-profile FlashScan photoelectric detector with 135°F (57°C) thermal. See DN-6935.

FSP-851R(A): Remote-test capable photoelectric detector for use with DNR(W) duct detector housings. See DN-6935.

FST-851(A): FlashScan thermal detector 135°F (57°C). See DN-6936.

FST-851R(A): FlashScan thermal detector 135°F (57°C) with rate-of-rise. See DN-6936.

FST-851H(A): FlashScan 190°F (88°C) high-temperature thermal detector. See DN-6936.

FAPT-851(A): FlashScan Acclimate Plus low-profile multi-sensor detector. See DN-6937.

FSL-751(A): FlashScan VIEW laser photo detector. See DN-6886.

DNR(A): InnovairFlex low-flow non-relay duct-detector housing (order FSP-851R separately). Replaces FSD-751PL/FSD-751RPL. See DN-60429.

DNRW(A): Same as above with NEMA-4 rating, watertight. See DN-60429.

B224RB: Low-profile relay base. See DN-60054.

B224BI: Isolator base for low-profile detectors. See DN-60054.

B210LP: Low-profile base. Standard U.S. style. Replaces B710LP. See DN-60054.

B501(A): European-style, 4" (10.16 cm) base. See DN-60054.

B200S: Intelligent programmable sounder base, capable of producing a variety of tone patterns including ANSI Temporal 3. Compatible with synchronization protocol. See DN-60054.

B200S-LF: Low-frequency version of B200S. See DN-60054.

B200SR: Sounder base, Temporal 3 or Continuous tone. See DN-60054.

B200SR-LF: Low-frequency version of B200SR. See DN-60054.

FMM-1: FlashScan monitor module. See DN-6720.

FDM-1(A): FlashScan dual monitor module. See DN-6720.

FZM-1(A): FlashScan two-wire detector monitor module. See DN-6720.

FMM-101(A): FlashScan miniature monitor module. See DN-6720.

FCM-1(A): FlashScan control module. See DN-6724.

FCM-1-REL(A): FlashScan releasing control module. See DN-60390.

FRM-1(A): FlashScan relay module. See DN-6724.

FDRM-1(A): FlashScan dual monitor/dual relay module. See DN-60709.

NBG-12LX: Manual pull station, addressable. See DN-6726.

ISO-X: Isolator module. See DN-2243.

ISO-6: Six Fault isolator module. For Canadian applications order ISO-6A. See DN-60844.

XP6-C(A): FlashScan six-circuit supervised control module. See DN-6924.

XP6-MA(A): FlashScan six-zone interface module; connects intelligent alarm system to two-wire conventional detection zone. See DN-6925.

XP6-R(A): FlashScan six-relay (Form-C) control module. See DN-6926.

XP10-M(A): FlashScan ten-input monitor module. See DN-6923.

SLC-IM: SLC integration module, for VESDA net detectors. See DN-60755.

ENCLOSURES, CHASSIS, AND DRESS PLATES

CAB-BM Marine System: Protects equipment in shipboard and waterfront applications. Also order **BB-MB** for systems using 100 AH batteries. For a full list of required and optional equipment, see DN-60688.

BB-UZC: Backbox for housing the UZC-256. Required for NFS-320 applications. Black. For red, order BB-UZC-R.

NFS-LBB: Battery Box (required for batteries larger than 26 AH).

NFS-LBBR: Same as above, but red.

SEISKIT-320/B26: Seismic mounting kit. Required for seismic-certified applications with NFS-320 and BB-26. Includes battery bracket for two 26 AH batteries.

SEISKIT-BB25: Seismic mounting kit for the BB-25. Includes battery bracket for two 26 AH batteries.

SEISKIT-LBB: Seismic kit for the NFS-LBB. Includes battery bracket for two 55 AH batteries.

OTHER OPTIONS

411: Slave Digital Alarm Communicator. See DN-6619.

411UDAC: Digital Alarm Communicator. See DN-6746.

IPDACT-2/2UD, IPDACT Internet Monitoring Module: Connects to primary and secondary DACT telephone output ports for internet communications over customer-provided Ethernet connection. Requires compatible Teldat VisorALARM Central Station Receiver. Can use DHCP or static IP. See DN-60408.

IPSPLT: Y-adaptor option allow connection of both panel dialer outputs to one IPDACT-2/2UD cable input.

IPENC: External enclosure for IPDACT, includes IPBRKT mounting bracket; Red. For Black order **IPENC-B**.

IPGSM-4G: Internet and Digital Cellular Fire Alarm Communicator. Provides selectable configurable paths: cellular only, IP only, or IP primary with cellular backup. Connects to the primary and secondary ports of a DACT. See DN-60769.

BACKBOXES

NOTE: "C" suffix indicates ULC-Listed model:

ABF-1B Annunciator Flush Box.

ABF-1DB(C) Annunciator Flush Box with Door.

ABF-2B Annunciator Flush Box

ABF-2DB(C) Annunciator Flush Box with Door

ABF-4B Annunciator Flush Box

ABS-1TB(C) Annunciator Surface Box

ABS-1B(C) Annunciator Surface Box

ABS-2B Annunciator Surface Box

ABS-2D(C) Annunciator Surface Box

ABS-4D(C) Annunciator Surface Box

NFS-320-RB: Replacement board with central processing unit (CPU). *NOTE: Keypad must be removed before shipping old unit out for repair.*

- NFS-320-RBE: Replacement CPU, Export.
- NFS-320-RB-PO: Replacement CPU, Portuguese.
- NFS-320-RB-POE: Replacement CPU, Export, Portuguese.
- NFS-320-RB-FFR: Replacement CPU, Canadian French.
- NFS-320-RB-SP: Replacement CPU, Spanish.
- NFS-320-RB-SPE: Replacement CPU, Export, Spanish.

NOTE: For other options including compatibility with retrofit equipment, refer to the panel's installation manual, the SLC manual, and the Device Compatibility Document.

System Specifications

SYSTEM CAPACITY

- Intelligent Signaling Line Circuits 1
- Intelligent detectors 159
- Addressable monitor/control modules 159
- Programmable internal hardware and output circuits 4
- Programmable software zones 99
- Special programming zones 14
- LCD annunciators per NFS-320/-320E 32
- ACS annunciators per NFS-320/-320E 32 addresses x 64 points

SPECIFICATIONS

- Primary input power
 - NFS-320: 120 VAC, 50/60 Hz, 5.0 A.
 - NFS-320E: 220/240 VAC, 50/60 Hz, 2.5 A.
- Current draw (standby/alarm):
 - NFS-320(E) board: 0.250 A. Add 0.035 A for each NAC in use.
 - KDM-R2 (Backlight on): 0.100 A.
- Total output 24 V power: 6.0 A in alarm.

NOTE: The power supply has a total of 6.0 A of available power. This is shared by all internal circuits. See Installation Manual for a complete current draw calculation sheet.

- Standard notification circuits (4): 1.5 A each.
- Resettable regulated 24V power: 1.25 A.
- Two non-resettable regulated 24V power outputs:
 - 1.25 A.
 - 0.50 A.
- Non-resettable 5V power: 0.15 A.
- Battery charger range: 18 AH – 200 AH. Use separate cabinet for batteries over 26 AH.
- Float rate: 27.6 V.

CABINET SPECIFICATIONS

NFS-320 cabinet dimensions:

- Backbox: 18.12 in. (46.025 cm) width; 18.12 in. (46.025 cm) height; 5.81 in. (14.76 cm) depth.
- Door: 18.187 in. (46.195 cm) width; 18.40 in. (46.736 cm) height; 0.75 in. (1.905 cm) depth.
- Trim ring: Molding width is 0.905 in. (2.299 cm).
- Shipping weight (without batteries): 36.15 lb. (16.4 kg).

TEMPERATURE AND HUMIDITY RANGES

This system meets NFPA requirements for operation at 0 – 49°C/ 32 – 120°F and at a relative humidity 93% ± 2% RH (noncondensing) at 32°C ± 2°C (90°F ± 3°F). However, the useful life of the system's standby batteries and the electronic components may be adversely affected by extreme temperature ranges and humidity. Therefore, it is recommended that this system and its peripherals be installed in an environment with a normal room temperature of 15 – 27°C/60 – 80°F.

AGENCY LISTINGS AND APPROVALS

The listings and approvals below apply to the basic NFS-320 control panel. In some cases, certain modules may not be listed by certain approval agencies, or listing may be in process. Consult factory for latest listing status.

- **UL/ULC Listed:** S635.
- **FM Approved.**

- **CSFM:** 7165-0028:0243.
- **MEA:** 128-07-E.
- **Fire Dept. of New York:** COA# 6212.
- **City of Chicago.**
- **ULC Listed:** S527-11

NOTE: For additional information on UL- and ULC-listed model NFS-320C, see DN-60085. For information on NFS-320SYS, see DN-60637.

Marine Applications: Marine approved systems must be configured using components itemized in this document. (See Main System Components, in "Product Line Information.") Specific connections and requirements for those components are described in the installation document, PN 54756. When these requirements are followed, systems are approved by the following agencies:

- **US Coast Guard** 161.002/50/0, 161.002/55/0 (Standard 46 CFR and 161.002).
- **Lloyd's Register** 11/600013 (ENV 3 category).
- **American Bureau of Shipping (ABS)** Type Approval.

NOTE: For information on marine applications, see DN-60688.

STANDARDS

The NFS-320 complies with the following UL Standards and NFPA 72, International Building Code (IBC), and California Building Code (CBC) Fire Alarm Systems requirements:

- **UL 864** (Fire).
- **UL 1076** (Burglary).
- **UL 2572** (Mass Notification Systems). (NFS-320 version 20 or higher).
- **ULC-S527-11** Standard for the Installation of Fire Alarm Systems.
- **LOCAL** (Automatic, Manual, Waterflow and Sprinkler Supervisory).
- **AUXILIARY** (Automatic, Manual and Waterflow) (requires TM-4).
- **REMOTE STATION** (Automatic, Manual, Waterflow and Sprinkler Supervisory) (requires TM-4).
- **PROPRIETARY** (Automatic, Manual, Waterflow and Sprinkler Supervisory). *Not applicable for FM.*
- **CENTRAL STATION** (Automatic, Manual, Waterflow and Sprinkler Supervisory) (requires DACT).
- **EMERGENCY VOICE/ALARM.**
- **OT, PSDN** (Other Technologies, Packet-switched Data Network).
- **IBC 2012, IBC 2009, IBC 2006, IBC 2003, IBC 2000** (Seismic).
- **CBC 2007** (Seismic).

IntelliQuad™, NOTIFIRE-NET™, ONYXWorks™, and SWIFT™ are trademarks; and Acclimate® Plus™, FirstCommand®, FlashScan®, Intelligent FFAST®, NOTIFIER®, ONYX®, VeriFire®, and VIEW® are registered trademarks of Honeywell International Inc. Microsoft® and Windows® are registered trademarks of Microsoft Corporation. IBM® is a registered trademark of IBM Corporation. ©2017 by Honeywell International Inc. All rights reserved. Unauthorized use of this document is strictly prohibited.



This document is not intended to be used for installation purposes. We try to keep our product information up-to-date and accurate. We cannot cover all specific applications or anticipate all requirements. All specifications are subject to change without notice.



Country of Origin: USA

For more information, contact Notifier. Phone: (203) 484-7161, FAX: (203) 484-7118.
www.notifier.com

CALIFORNIA DEPARTMENT OF FORESTRY & FIRE PROTECTION
OFFICE OF THE STATE FIRE MARSHAL
FIRE ENGINEERING - BUILDING MATERIALS LISTING PROGRAM



LISTING SERVICE

LISTING No. 7165-0028:0243

Page 1 of 4

CATEGORY: 7165 -- FIRE ALARM CONTROL UNIT (COMMERCIAL)

LISTEE: NotifierOne Fire-Lite Place, Northford, CT 06472-1653
Contact: Vladimir Kireyev (203) 484-6277 Fax (203) 484-7309
Email: vladimir.kireyev@honeywell.com

DESIGN: Models NFS2-640, NFS-320/C (R), and NFS-320SYS fire alarm control units. Local, auxiliary, remote station (PPU), proprietary (PPU), central station (PPU), manual, automatic, waterfowl and sprinkler supervisory services. Also suitable for releasing service, Process Management and Emergency Voice/Alarm communication System *. Model numbers may be followed by an "R" suffix representing the enclosure color being red. Refer to listee's data sheet for additional detailed product description and operational considerations. System components:

ACM-8R, -16AT, -32A, -24AT, -48A; Annunciator Control Modules
ACPS-610, AMPS-24; Addressable power supply/charger
ADP-4B, -A4, -1, -2, DP-DISP2; Dress Panel
AEM-16AT, -32A, -24AT, -48A; Annunciator Expander Modules
AFM-16A, -16AT, -32A; Annunciator Fixed Modules
AKS-1B; Annunciator Key Switch
APS2-6R; Power supply
BB-100, -200, NFS-LBB/-LBBR; Battery Boxes
BGRA-SCS, BGRB-SCS; Smoke Control Station
BMP-1; Blank Module
BP-4, BP2-4; Battery Dress Plates
CAB-3/-4 Series; Enclosure
CAB-RP, CAB-RPR; Cabinets
CEF-SCS; Smoke Control Station
CHS-4, CHS-4N, CHS-4L; Chassis
CPU2-640, CPU-320SYS; CPU Board
CRT-2; Display Terminal
DP-1B; Blank Panel
DPA-1A4/1/2, DP-DISP2; Dress Panel
DPI-232; Panel Interface
DR-A4, DR-A4B, DR-A4BR, DR-A4R; Door Assembly
DR-AA4, DR-AA4B, DR-AA4BR, DR-AA4R; Door Assembly
DR-B3F; Door Assembly
DR-B4, DR-B4B, DR-B4BR, DR-B4R; Door Assembly
DR-C4, DR-C4B, DR-C4BR, DR-C4R; Door Assembly
DR-D4, DR-D4B, DR-D4BR, DR-D4R; Door Assembly

*Rev. 10-29-13 gt



This listing is based upon technical data submitted by the applicant. CSFM Fire Engineering staff has reviewed the test results and/or other data but does not make an independent verification of any claims. This listing is not an endorsement or recommendation of the item listed. This listing should not be used to verify correct operational requirements or installation criteria. Refer to listee's data sheet, installation instructions and/or other

Date Issued: **July 01, 2018**

Listing Expires **June 30, 2019**

Authorized By: **DAVID CASTILLO, Program Coordinator**

Fire Engineering Division

EQ Series; Cabinets
 EQBB-B4, EQBB-C4, EQBB-D4; Backbox Assembly
 EQDR-B4, EQDR-C4, EQDR-D4; Door Assembly
 FCM-1, FCM-1-REL; Releasing Control Module
 FCPS-24S6, -24S8; Field Charger/Power Supply
 FDM-1; Dual Monitor Module
 FDRM-1: Multiple Module with two Relay Outputs
 FDU-80/-80G; Remote Annunciator
 FIRSTVISION-LCD/ENC; Interactive Firefighters' display/enclosure
 FRM-1; Relay Module
 FTM-1; Control Module
 FZM-1, FMM-1, FMM-101; Monitor Modules
 HS-NCM-W/-MF/-SF/-WMF/-WSF/-MSSF; High Speed Network Control Modules
 IPDACT-2/-2UD; IP Fire Alarm Communicator
 ISO-X; Isolator Module
 KAPS-24, CPS-24; Power Supply
 KDM-R2; Keyboard Display Module
 LCD-80, -160; Annunciators
 LCD-80TM; Annunciator Terminal Module LCD
 LCD2-80; Remote Annunciator
 LDM-32/-E32/-R32; Lamp Driver Module
 LEM-320/ELEM-320; Loop Expander Module
 NBG-12LRA; Agent Releasing Abort Station
 NBG-12LX; Addressable Manual Pull Station
 NCA, NCA-2; Network Communication Annunciator
 NCM-W, -F; Network Control Module
 NCS4-W-ONYX, NCS4-F-ONYX; Network Control Station
 NCS5-W-ONYX, NCS5-F-ONYX; Network Control Station
 NFS-LBB/NFS-LBBR; Battery Box/Red
 NFS-320SYS; Chassis
 NFV-25/50, NFV-25/50ZS/ZST; Voice Evacuation Control Panels
 NFV-25/50DA, NFV-25/50DAZS; Distributed Audio Panels
 ONYXWorks-EW/-NW/-NF/-HNW/-HNMF/-HNSF/-TS/-EW-TS/-NF-TS/-HW-TS/
 -HNMFT/-HNSFT/-HNWT; PC workstation for NOTI•FIRE•NET, Wire/Fiber/
 with Touch screen monitors
 PRN-6; Printer
 RKS-S; Remote Security Key Switch
 RPT-W, -485W; Repeater Wire
 RPT-F; Repeater Fiber
 RPT -485FW; Repeater Fiber/Wire
 RSA-SCS, RSB-SCS, RSC-SCS, RSD-SCS, RSE-SCS; Smoke Control Station
 SBB-A3F; Backbox Assembly
 SBB-A4, SBB-A4R, SBB-AA4, SBB-AA4R; Backbox Assembly
 SBB-B4, SBB-B4R-L8, SBB-C4, SBB-C4R; Backbox Assembly
 SBB-D4, SBB-D4R; Backbox Assembly

*Rev. 10-29-13 gt



This listing is based upon technical data submitted by the applicant. CSFM Fire Engineering staff has reviewed the test results and/or other data but does not make an independent verification of any claims. This listing is not an endorsement or recommendation of the item listed. This listing should not be used to verify correct operational requirements or installation criteria. Refer to listee's data sheet, installation instructions and/or other

Date Issued: **July 01, 2018**Listing Expires **June 30, 2019**Authorized By: **DAVID CASTILLO, Program Coordinator***Fire Engineering Division*

SCE-8; Smoke Control Expander
 SCS-8L; Smoke Control Lamp Driver Station
 SCE-8L; Smoke Control Expander Lamp
 SCS-8; Smoke Control Station
 STS-1; Security Tamper Switch
 TM-4; Transmitter Module
 TR-A4/-B3N/-B4/-C4/-D3N/-D4; Trim Ring
 UDACT, UDACT-2; Universal DACT
 UZC-256; Universal Zone Coder
 VP-2B; Dress Panel
 XP5-C/-M; Transponder Modules
 XP6-C; Supervised Control Modules
 XP6-MA; Six Zone Interface Modules
 XP6-R; Six Relay Control Modules
 XP10-M(A); Ten Input Monitor Modules
 XPM-8L; Transponder Monitor Modules

The following models are intended for use on NFS2-640 only:

AA-30, -100, -120; Amplifiers
 ACT-1, -2, -4, -25, -70; Audio Coupling Transformer
 ADDR-B4/-B4R/-C4/-C4R/-D4/-D4R; Door Assemblies
 AMG-E; Audio Message Generator
 AVL-1; Audio Voice Link
 BDA-25V/-70V; Backup Digital Audio Amplifiers
 CHS2-M2, CA-1, CA-2; Chassis
 CMIC-1, CMIC-RP; Microphone Assembly
 DAA-5025/-5070; Digital Audio Amplifiers
 DAA-5025F/DAA-5025SF; Digital Audio Amplifiers
 DAA-5070F/DAA-5070SF; Digital Audio Amplifiers, Fiber Mode
 DAA-75 Series; Digital Audio Amplifiers
 DAA-7525, DAA-7525F, DAA-7525SF; Digital Audio Amplifiers
 DAA2-5025/-5070/-7525; Digital Audio Amplifiers
 DAX-3525/-3570/-5025/-5070; Digital Audio Amplifiers
 DS-AMP/E; Digital Series Audio Amplifier
 DS-BDA; Digital Series Backup Amplifier
 DS-DB; Digital Series Distribution Board
 DS-FM, DS-RFM, DS-SFM; Digital Series Fiber Module
 DVC; Digital Voice Command
 DVC-EM/-EMF/-EMSF; Digital Voice Command Extended Memory Module
 DVC-RPU; Remote Paging Unit
 FFT-7, -7S; Fire Fighter's Telephone
 FHS; Fireman's Handset
 FPJ; Fireman's Phone Jack
 RM-1, RM-1SA; Remote Microphone

*Rev. 10-29-13 gt



This listing is based upon technical data submitted by the applicant. CSFM Fire Engineering staff has reviewed the test results and/or other data but does not make an independent verification of any claims. This listing is not an endorsement or recommendation of the item listed. This listing should not be used to verify correct operational requirements or installation criteria. Refer to listee's data sheet, installation instructions and/or other

Date Issued: **July 01, 2018**

Listing Expires **June 30, 2019**

Authorized By: **DAVID CASTILLO**, Program Coordinator
 Fire Engineering Division

TELH-1; Telephone Assembly
XPIQ; Transponder Quad Intelligent Audio

INSTALLATION: In accordance with listee's printed installation instructions, applicable codes & ordinances and in a manner acceptable to the authority having jurisdiction.

MARKING: Listee's name, model number, electrical ratings, and UL Label

APPROVAL: Listed as fire alarm control units suitable for use in high-rise applications when used in conjunction with separately listed compatible initiating and indicating devices. *Control units may be used with Notifier's First Command NFC-50/100 emergency voice evacuation panels (CSFM # 6911-0028:0265). This control unit can generate the temporal code pattern fire alarm signal as required per NFPA 72. Refer to manufacturer's Installation Manual for details. This control unit meets the requirements of UL Standard 864, 9th Edition.

NOTE:

1. For Fire Alarm Verification feature (delay of fire alarm signal), the maximum Retard/Reset/Restart period shall not exceed 30 Seconds.
2. Combined with 7170-028:244

*Rev. 10-29-13 gt



This listing is based upon technical data submitted by the applicant. CSFM Fire Engineering staff has reviewed the test results and/or other data but does not make an independent verification of any claims. This listing is not an endorsement or recommendation of the item listed. This listing should not be used to verify correct operational requirements or installation criteria. Refer to listee's data sheet, installation instructions and/or other

Date Issued: **July 01, 2018**

Listing Expires **June 30, 2019**

Authorized By: **DAVID CASTILLO**, Program Coordinator
Fire Engineering Division

ACPS-610(E)

Addressable Charger/Power Supply

NOTIFIER[®]
by Honeywell

Power Supplies

General

The ACPS-610(E) is an auxiliary power supply with a battery charging option and a host of special features. Selectable charging options allow the ACPS-610(E) to provide 6 amps of shared power to four outputs while charging batteries from 12 to 200 AH, or 10 amps of shared power when the unit is configured for use with an external battery charger. Four individually addressable outputs can be independently configured for auxiliary power or Notification Appliance Circuits (NAC). NAC outputs support notification appliance synchronization for devices manufactured by System Sensor[®], Wheelock, and Gentex. An option to disable battery charging allows the system designer to use the four built-in circuits to distribute 10 amps of power for general purposes, excluding NAC applications.

The ACPS-610(E) is compatible with NOTIFIER intelligent fire alarm control panels using CLIP and FlashScan[®] protocol.

Features

- Certified for seismic applications when used with the appropriate seismic mounting kit.
- Approved for Marine applications when used with listed compatible equipment (see DN-60688).
- Provides 6.0 A of NAC power or 10 A of general purpose power.
- Four Class B (Style Y) or four Class A (Style Z) outputs, individually addressable by the FACP.
- When built-in outputs are configured for NAC operation, each circuit supports strobe synchronization with the following manufacturers' audio/visual devices: System Sensor[®] (SpectrAlert[®] and SpectrAlert Advance Series) or Wheelock or Gentex.
- Each circuit can be software-selected for use as: a Notification Appliance Circuit, general purpose 24 VDC power, four-wire detector power, or door holder.
- Steady, March Time (120 PPM), Two Stage, Temporal, or UZC Zone-Coded and Non-Coded devices - software-selectable by circuit.
- Universal Zone Coder (UZC-256) option supports for programmable coded outputs. Up to 256 different codes.
- Auxiliary Outputs: 24V @ 0.5A and 5V @ 0.15A.
- Charges 12 to 200 AH batteries with full supervision. The charger on the ACPS may be disabled via software. When disabled, a separate, external charger is required, for example a CHG-120.
- May be used to provide battery backup for multiple ACPS supplies.
- AC loss detection, brownout detection, and AC loss delay reporting.
- Power-limited outputs.
- Isolated Signaling Line Circuit (SLC) interface.
- Selectable ground fault detection.
- Canadian two stage operation.

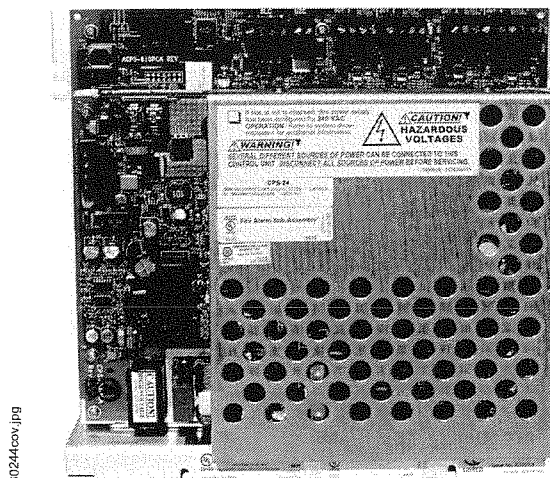

60244rev.jpg

Specifications

- Primary (AC) power:
 - ACPS-610: 120 VAC, 50/60 Hz input, 5.0 A maximum.
 - ACPS-610E: 220/240 VAC, 50/60 Hz input, 2.5 A maximum.
- Output voltage: 24 VDC electrically regulated and power limited (under primary AC mains). Under secondary power, 20.4 to 26.4 VDC.
- Output circuits - TB3, TB4, TB5, TB6 on Main Board: 1.5 A maximum for any NAC output circuit. 2.5 A maximum for any Power output with battery charger disabled.
- Secondary power (battery) charging circuit - lead-acid battery charger which will charge 12 to 200 AH batteries. Maximum charger current - 5.0 A.
- Secondary power auxiliary outputs - TB2 on CPS-24 Board:
 - 24V @ 0.5A, power limited.
 - 5V @ 0.15A, power limited.
- Wiring: utilizes wire sizes 12 to 18 AWG (3.1 to 0.78 mm²).
- SLC specifications: Average SLC current is 1.287 mA. SLC data is transmitted between 24.0 VDC, 5 VDC, and 0 VDC at approximately 3.33 Kbaud.
- Battery fuse (F2): 15A, Fast-acting.
- Weight: 4.5 lb.

ACPS Programming

The ACPS-610(E) is programmable via the simple-to-use PK-PPS programming utility, which requires a Windows[®] PC with a USB port and cable. Programming may be performed during an on-line session with the ACPS-610(E), or previously saved programs may be downloaded to individual ACPS-610(E) units. The ACPS-610(E) requires the use of a minimum of 5 SLC address points, and will use up to 14 SLC address points to fulfill requirements for Canadian supervision and two stage operation.

NOTE: PK-PPS is available for download from www.magnifire.com.

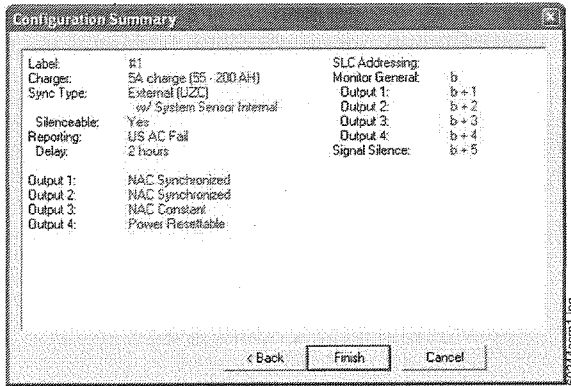

Example of Programming
for the ACPS-610 Using 6 Addresses

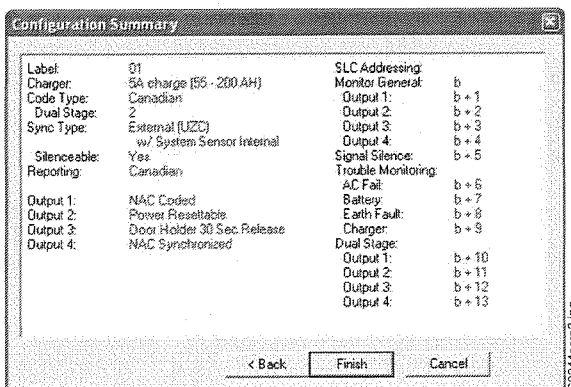

Example for ACPS-610
Using Canadian Reporting with Two Stage

Listings and Approvals

These listings and approvals apply to the modules specified in this document. In some cases, certain modules or applications may not be listed by certain approval agencies, or listing may be in process. Consult factory for latest listing status.

- **UL Listed:** S635.
- **ULC Listed:** S635.
- **FM Approved.**
- **CSFM:** 7315-0028:0248, 7165-0028:0224, 7165-0028:0243.
- **MEA #30-08-E.**
- **FDNY:** COA #6085, #6098.

When used with the MARINE-EQ, appropriate seismic bracket, and marine approved devices, the ACPS-610(E) is approved by the following agencies:

- US Coast Guard: 161.002/50/0 (Standard 46 CFR).
- Lloyd's Register: 11/600013 (ENV 3 category).
- American Bureau of Shipping (ABS).

Product Line Information

ACPS-610: Addressable charger power supply, with selectable built-in synchronization, and four built-in control modules. Several mounting options available (see below).

ACPS-610E: Same as ACPS-610, but configured for 220/240 VAC operation.

CAB-PS1: The CAB-PS1 can house one ACPS-610(E) and two 12 AH batteries. Dimensions: 15.218" (38.654 cm) high x 14.5" (36.83 cm) wide x 3.562" (9.048 cm) deep with door.

SEISKIT-PS/2/4: Seismic kit for mounting ACPS-610 in a CAB-PS1. Includes bracket for two 12 AH batteries.

DR-PS1: When installing an ACPS-610(E) into an older version of the CAB-PS1 used for an ACPS-2406(E), the new wider door must be ordered for use with the older version cabinet.

BB-25: The BB-25 can house one ACPS-610(E) and two 12 volt, 26 AH batteries.

BB-100: The BB-100 can house one ACPS-610(E) and two 12 volt, 55 AH or 100 AH AH batteries.

BB-200: The BB-200 can house one ACPS-610(E) and four 12 volt, 100 AH batteries.

CAB-4 Series: The ACPS-610(E) can mount in any of the CAB-4 Series cabinets with CHS-PS or CHS-BH. See DN-6857.

EQ Cabinet Series: The ACPS-610(E) can mount in any of the EQ Cabinet Series cabinets using CHS-6. See DN-60229.

MARINE-EQ System: Protects equipment in shipboard and waterfront applications. For a full list of required and optional equipment, see DN-60688.

CHS-PS/CHS-6: Chassis used to mount the ACPS-610(E) in row 1, 2, or 3 of the CAB-4 or EQ series enclosure.

CHS-BH: Battery mounting chassis that holds up to two 12AH batteries on a CHS-PS.

Batteries: ACPS-610(E) battery charging circuit range is 12 - 200 AH. See DN-6933.

Notifier®, FlashScan®, System Sensor®, and SpectraAlert® are registered trademarks of Honeywell International Inc. Windows® is a registered trademark of Microsoft.

©2012 by Honeywell International Inc. All rights reserved. Unauthorized use of this document is strictly prohibited.



This document is not intended to be used for installation purposes.
We try to keep our product information up-to-date and accurate.
We cannot cover all specific applications or anticipate all requirements.
All specifications are subject to change without notice.



Made in the U.S. A.

For more information, contact Notifier. Phone: (203) 484-7161, FAX: (203) 484-7118.
www.notifier.com

CALIFORNIA DEPARTMENT OF FORESTRY & FIRE PROTECTION
OFFICE OF THE STATE FIRE MARSHAL
FIRE ENGINEERING - BUILDING MATERIALS LISTING PROGRAM



LISTING SERVICE

LISTING No. 7315-0028:0248

Page 1 of 1

CATEGORY: 7315 -- POWER UNITS

LISTEE: NotifierOne Fire-Lite Place, Northford, CT 06472-1653
Contact: Vladimir Kireyev (203) 484-6277 Fax (203) 484-7309
Email: vladimir.kireyev@honeywell.com

DESIGN: Models APS2-6R*, APS2-6RE* power supply and ACPS-610, ACPS-610E addressable charger/power supply. Models ACPS-610 and ACPS-610E can be configured to drive four notification appliance circuits or, it may be configured to provide four-wire detector power or general purpose power. Model APS2-6R* can provide two power-limited output circuits (24VDC, 3A max. each) or one non power-limited (6A max). Refer to listee's data sheet for additional detailed product description and operational considerations.

RATING:
ACPS-610: 120 V, 50/60 Hz, 5.0 A
ACPS-610E: 240 V, 50/60 Hz, 2.5 A
*APS2-6R: 120 V, 50/60 Hz, 2.9 A
*APS2-6RE: 220-240 V, 50/60 Hz, 1.5 A

INSTALLATION: In accordance with listee's printed installation instructions, applicable codes and ordinances and in a manner acceptable to the authority having jurisdiction.

MARKING: Listee's name, product designation, electrical rating and UL label.

APPROVAL: Listed as auxiliary addressable power supply and battery charger (only for ACPS-610*) for use with separately listed electrically and functionally compatible fire alarm control units.

*Rev. 07-20-09 bh



This listing is based upon technical data submitted by the applicant. CSFM Fire Engineering staff has reviewed the test results and/or other data but does not make an independent verification of any claims. This listing is not an endorsement or recommendation of the item listed. This listing should not be used to verify correct operational requirements or installation criteria. Refer to listee's data sheet, installation instructions and/or other

Date Issued: **July 01, 2018**

Listing Expires **June 30, 2019**

Authorized By: **DAVID CASTILLO**, Program Coordinator
Fire Engineering Division

NFC-50/100(E)

Notifier First Command



Voice Evacuation & Emergency Communications System

General

Notifier's First Command NFC-50/100 and NFC-50/100E are multipurpose emergency voice evacuation panels for fire applications, mass notification applications, or both. The First Command delivers 50 or 100 watts of audio power for distribution to up to eight speaker circuits (i.e. zones). The NFC-50/100(E) comes standard with a single speaker circuit and a built-in 50 watt, 25V amplifier. A secondary 50 watt amplifier (NFC-BDA-25/70V) can be added for single speaker circuit backup or to increase system capacity to two speaker circuits and an additional 50 watts of audio power. An optional NFC-CE6 module added to the NFC-50/100(E) will upgrade the system to a maximum of eight speaker circuit outputs. All speaker output circuits can be wired in either Style Y (Class B) or Style Z (Class A) configuration. The NFC-50/100(E) has fourteen field programmable messages (up to 60 seconds each), built-in field configurable pre- and post-announce tone generators and a fully supervised Notification Appliance Circuit (NAC) with 2.0 amps of synchronized NAC power. The NFC-50/100(E) includes three built-in Form-C relay contacts, (AC power, trouble and MNS active) a NAC follower and 500mA special application power. A built-in power supply delivers operational power and an onboard battery charger supports charging up to 26AH batteries (NFC cabinet holds up to 18AH batteries).

For fire protection applications, the NFC-50/100(E) is an adjunct (slave) to any UL listed FACP, providing reverse polarity or contact closure; can be used as a stand-alone unit for non-fire applications. For seamless integration between fire and mass notification, the NFC-50/100(E) can be directly activated via serial communication between the NFW2-100, NFS-320, or NFS2-640. Activation of the NFC-50/100(E) via other FACP's uses the eight on board Command Input Circuits (CMDs). Two of the eight CMD circuits (CMD 1 & CMD 2) can be individually field programmed for activation by an FACP Notification Appliance Circuit reverse polarity and all eight can be activated by a contact closure. In addition, the NFC-50/100(E) can be activated from a building's Private Branch Exchange (PBX) with the integral night ring feature.

All NFC-50/100(E) programming is done by using a simple, built-in programming utility accessed from any laptop. For added flexibility, the NFC-50/100(E) supports both 25V and 70V speaker output operation. By adding a 70V transformer conversion module (NFC-XRM-70V) or an additional 70 volt secondary amplifier (NFC-BDA-25/70V) the system supports 70 volt speaker devices.

The NFC-50/100(E) can expand in order to accommodate larger or more complex installations. To add more control and increase system capacity, any combination of up to eight external remote consoles (including the NFC-LOC, NFC-RPU, and NFC-RM) and up to eight distributed audio amplifiers (including the NFC-50DA(E), NFC-100DA(E) and NFC-125-DA(E) can be connected on the external data bus and audio riser data bus to create a fully integrated command center. A fully loaded system supports up to 1100 watts of total audio power and up to 24 speaker circuit outputs.

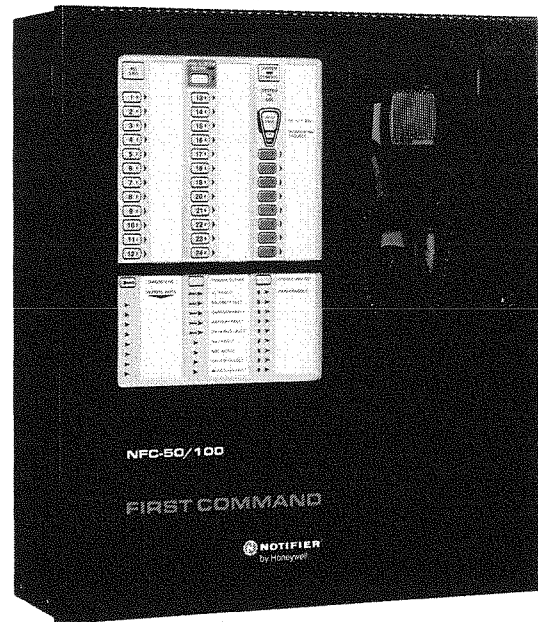

TYPICAL APPLICATIONS

- Schools
- Nursing Homes
- Factories
- Theaters
- Military facilities
- Restaurants
- Auditoriums
- Places of Worship
- Office Buildings

Features

- UL Listed to UL 2572 Communication (Control Units Mass Notification Systems) and UL 864 (emergency voice evacuation for fire)
- Modular design for system flexibility and easy expansion
- Removable terminal blocks
- 50 watts of 25V audio power (expandable to 100 watts) RMS
- 2 amp Notification Appliance Circuit (NAC) output, sync generator, or follower for System Sensor, Wheelock or Gen-tex protocols
- Optional 70V transformer available for the primary amplifier. (Note that speaker wiring continues to be supervised in standby, alarm and when background music is playing with this optional transformer installed)
- Eight Command Input Circuits to activate messages 1 to 8:
 - CMD1 and CMD2 are field selectable to be activated from 12 or 24 VDC Notification Appliance Circuits (reverse polarity) or contact closures
 - CMD3-CMD8 are activated by contact closures
- Speaker Circuits
 - Single Style Y (Class B) or Style Z (Class A) speaker Circuit

- Two Style Y (Class B) or Style Z (Class A) speaker circuits (with optional NFC-BDA-25/70V Audio Amplifier installed)
- Eight Style Y (Class B) or Style Z (Class A) speaker circuits (with optional NFC-BDA-25/70V and NFC-CE6 installed)
- 520Hz square wave tones available, which can be uploaded to the NFC-50/100 to meet NFPA Low Frequency requirements (Refer to the Device Compatibility Document 15378 for listed compatible speakers.)
- NFC-50/100(E) can be controlled by an FACP via the ANN/ACS (EIA-485) link of the NFW2-100, and via the ACS (EIA-485) link of the NFS-320 or NFS2-640. The NFS-320 or NFS2-640 must be firmware version 20.0 or higher.
- Certified for seismic applications when used with the appropriate seismic mounting kit
- Integral supervised microphone
- Microphone time-out feature which reverts back to pre-recorded message if emergency page exceeds the programmed time
- 14 recorded messages
- Field-selectable message and custom message recording capability using the local microphone, a USB port, or an external audio input
- External Audio Input can be used for background music
- Up to 60 second message duration for all messages
- Integral tone generators field selectable for multiple tone types
- Powered by integral AC power supply or batteries during AC fail
- Programmable delay of immediate, 2 hours or 6 hours reporting of AC Loss
- Piezo sounder for local trouble
- 100 event history log
- Three Form-C relays:
 - AC Power Loss Relay - TB1
 - System Trouble Relay - TB2
 - MNS Active - TB3
- 500mA (0.5A) Special Application (auxiliary power) output for addressable modules when interfaced with compatible addressable FACP's and End-of-Line power supervision relays
- System Status LEDs (Refer to "Controls and Indicators" in product manual LS10001-001NF-E.)
- Integral Dress Panel
- Optional TR-CE-B semi-flush trim ring
- Any combination of up to eight (8) external remote consoles:
 - Optional NFC-RM Remote Microphone (includes cabinet) See DN-60778.
 - Optional NFC-RPU Remote Page Unit (includes cabinet) See DN-60775.
 - Optional NFC-LOC Local operator console (includes cabinet) See DN-60777.
- Any combination of up to eight (8) distributed audio amplifiers:
 - Optional NFC-50DA(E) distributed amplifier, 50 watts. See DN-60776.
 - Optional NFC-125DA(E) distributed amplifier, 125 watts. See DN-60776.
 - Optional NFC-50/100 distributed amplifier with backup capability, 50/100 watts. See DN-60776.

Optional Internal Expansion Modules

NFC-CE6: Circuit Expander Module provides connections for up to six Style Z (Class A) or Style Y (Class B) speaker circuits. Circuits are configured through the web-based programming utility.

NFC-BDA-25V: 25V, 50 watt audio amplifier module. Adding a second speaker circuit increases the total NFC-50/100 power output to 100 watts or can also be used as a backup amplifier.

NFC-BDA-70V: 70V, 50 watt audio amplifier module. Adding a second speaker circuit increases the total NFC-50/100 power output to 100 watts or can also be used as a backup amplifier.

NFC-XRM-70V: 70V Transformer Conversion Module. Converts the NFC-50/100(E) primary amplifier to a 70V output. This transformer mounts directly to the NFC-50/100(E) main control board by two metal brackets.

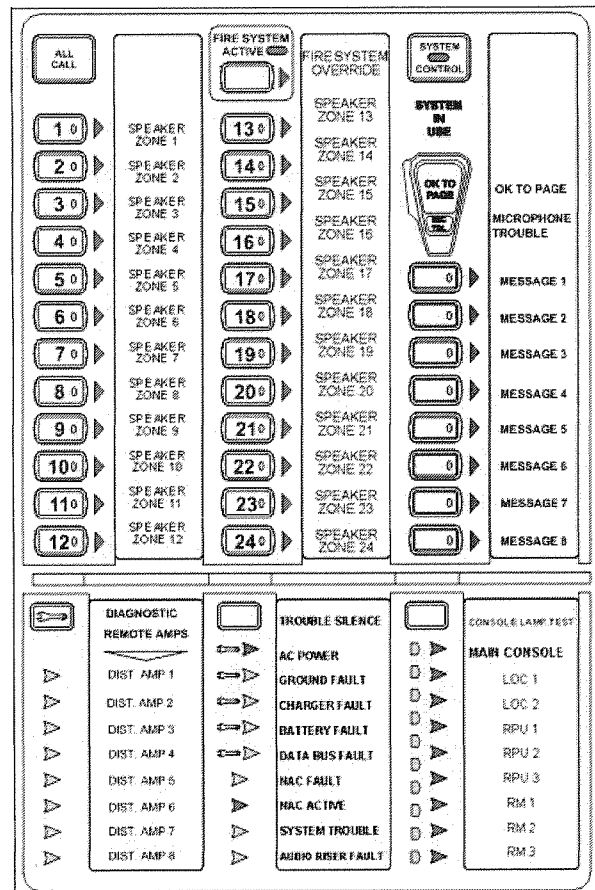

Control and Indicators

PUSH BUTTON CONTROLS

- All Call
- MNS Control
- System Control
- Speaker Select 1-24
- Message Select 1-14
- Diagnostic Select
- Trouble Silence
- Console Lamp Test

LED Status Indicators (visible with door closed)

| | |
|-------------------------------------|-------------------------------|
| Fire System Active (green) | LOC/RPU/RM 1-8 Active (green) |
| MNS Control (green) | Main Console Fault (yellow) |
| System Control (green) | AC Power (green) |
| System in Use (green) | Ground Fault (yellow) |
| Speaker Zone 1-24 Active (green) | Charger Fault (yellow) |
| Speaker Zone 1-24 Fault (yellow) | Battery Fault (yellow) |
| OK to Page (green) | Data Bus Fault (yellow) |
| Microphone Trouble (yellow) | NAC Fault (yellow) |
| Message 1-8 Active (red) | NAC Active (green) |
| Message 1-8 Fault (yellow) | System Trouble (yellow) |
| Remote Amplifier 1-8 Fault (yellow) | Audio Riser Fault (yellow) |
| LOC/RPU/RM 1-8 Fault (yellow) | |

LED Indicators (visible with door and dress panel open)

- Speaker Volume Control Fault (yellow).
- Option Card Fault (yellow).
- Amplifier Over Current Fault (yellow).

Product Line Information

NFC-50/100: (Primary Operating Console) 50 Watt, 25V single speaker zone emergency voice evacuation system, integral microphone, built in tone generator and 14 recordable messages.

NFC-50/100E: Export version (Primary Operating Console) 50 Watt, 25V single speaker zone emergency voice evacuation system, integral microphone, built in tone generator and 14 recordable messages. (240 VAC, 50Hz).

NFC-CE6: Speaker Circuit/Zone Expander Module.

NFC-BDA-25V: 25V, 50 watt audio amplifier module. Adding a second speaker circuit increases the total NFC-50/100 power output to 100 watts or can also be used as a backup amplifier.

NFC-BDA-70V: 70V, 50 watt audio amplifier module. Adding a second speaker circuit increases the total NFC-50/100 power output to 100 watts or can also be used as a backup amplifier.

NFC-XRM-70V: 70V Transformer Conversion Module. Converts the NFC-50/100(E) primary amplifier to a 70V output. This transformer mounts directly to the NFC-50/100(E) main control board by two metal brackets.

NFC-LOC: Local Operator Console (Complete user interface), *Please refer to the data sheet DN-60777 for more information.*

NFC-RPU: Remote Page Unit Hand held microphone, 14 message buttons. *Please refer to the data sheet DN-60775 for more information.*

NFC-RM: Remote Microphone only. *Please refer to the data sheet DN-60778 for more information.*

NFC-50DA: Distributed (Remote) Audio Amplifier, 50 watts. *Please refer to the data sheet DN-60776 for more information.*

NFC-50DAE: Export version. Distributed (Remote) Audio Amplifier, 50 watts. (240 VAC, 50Hz). *Please refer to the data sheet DN-60776 for more information.*

NFC-125DA: Distributed (Remote) Audio Amplifier, 125 watts. *Please refer to the data sheet DN-60776 for more information.*

NFC-125DAE: Export version. Distributed (Remote) Audio Amplifier, 125 watts. (240 VAC, 50Hz). *Please refer to the data sheet DN-60776 for more information.*

NFC-50/100DA: Distributed (Remote) Audio Amplifier with back up, 50 watts/100 watts at 25Vrms or 70Vrms. *Please refer to the data sheet DN-60776 for more information.*

NFC-50/100DAE: Export version. Distributed (Remote) Audio Amplifier with back up, 50 watts/100 watts (240 VAC, 50Hz). *Please refer to the data sheet DN-60776 for more information.*

NFC-BDA-BU: Expander card for ECC-50BDA remote amplifier for 100 watt primary / 50 watt back up operation. *Please refer to the data sheet DN-60776 for more information.*

NFC-CE4: Distributed Audio Speaker Circuit/Zone expander module.

NFC-FFT: Fire Fighter Telephone System. *Please refer to the data sheet DN-60779 for more information.*

NFC-RTZM: Remote Telephone Zone Module. *Allows for secure access to the NFC via cell phone or remote telephone means; not UL listed. Please refer to the data sheet DN-60818 for more information.*

SEISKIT-COMMENC: Seismic kit for the NFC-50/100. Includes battery bracket for two 12 AH or 18 AH batteries.

N-FPJ: Remote Phone Jack.

FHS-F: Fire Fighters Remote Handset.

FHSC-R: Fire Fighters Handset Cabinet Recessed.

FHSC-S: Fire Fighters Handset Cabinet Surface Mount

TR-CE-B: Optional Trim Ring.

THUMBLTCH: Optional Thumb Latch. (Non UL-Listed).

CHG-75: 25 to 75 ampere-hours (AH) External Battery Charger.

CHG-120: 25-120 ampere-hours (AH) External Battery Charger.

ECC-MICROPHONE: Replacement Microphone only.

BAT-1270: Battery, 12 volt, 7.0 AH (Two required).

BAT-12120: Battery, 12 volt, 12.0 AH (Two required).

BAT-12180: Battery, 12 volt, 18.0 AH (Two required).

BAT-12260: Battery, 12 volt, 26.0 AH (Two required).

BB-26: Battery cabinet mounts up to two 26 AH batteries.

Wiring Requirements

See product manual, part number LS10001-001NF-E for detailed wiring requirements.

Total System Capacity: (NFC-50/100(E) only)

- Total Built-in Audio Power: 50 Watts.
- Total Expandable Audio Power: 100 Watts.
- Total Built-in Speaker Circuits: 2.
- Total Expandable Speaker Circuits: 8.
- Audio Message Max Time Duration: 60 seconds.
- External Audio Input: 1.

Total System Capacity: (Fully Loaded System)

- Total Distributed Audio Power: 1100 Watts.
- Total Speaker Circuits Per System: 24.
- Total Remote Consoles Supported: 8.
- Total Distributed Audio Amplifiers Supported: 8.

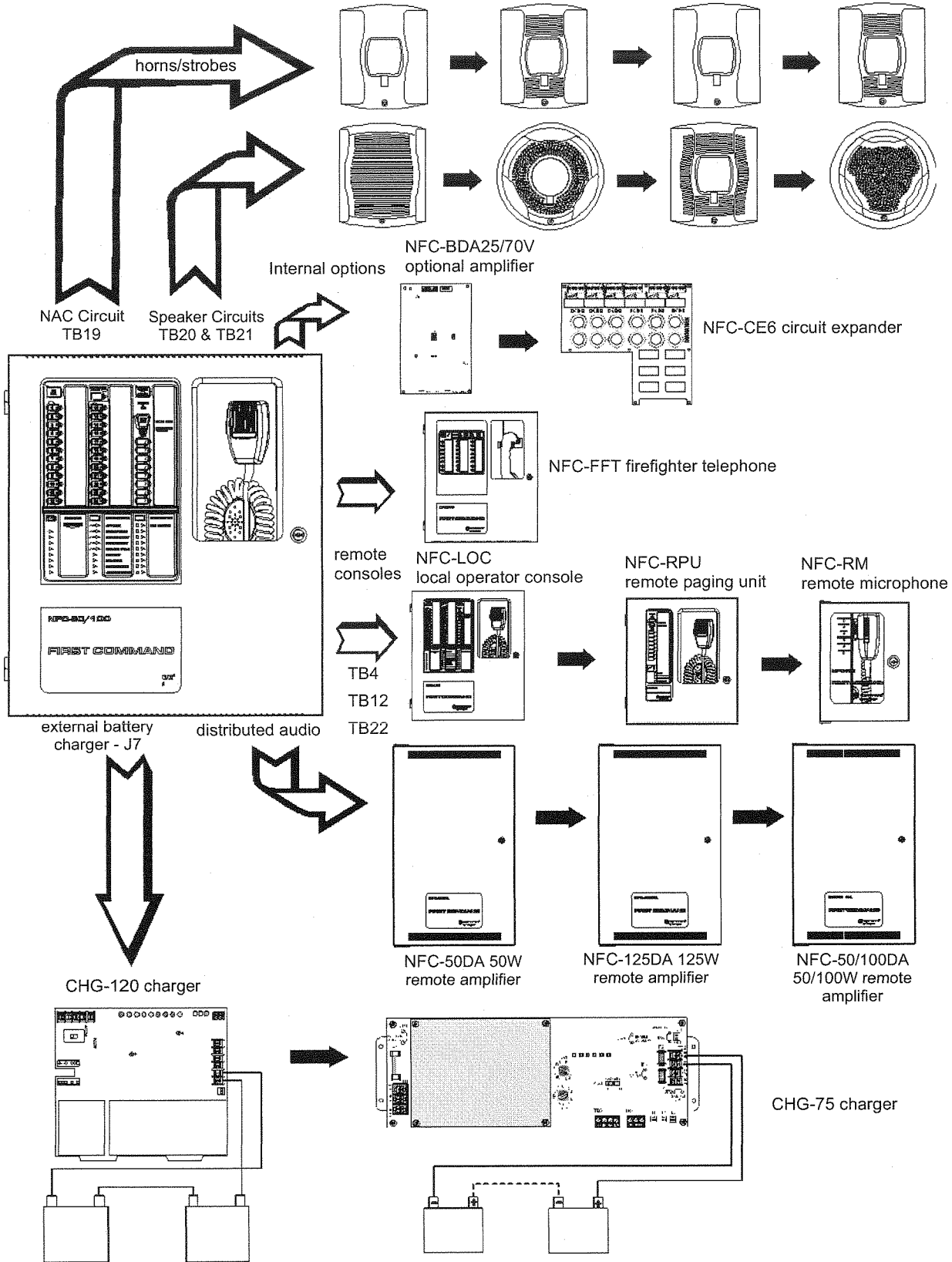

NFC-50/100(E) FirstCommand (Possible Configurations)

Electrical Specifications

PRIMARY (AC) POWER (TB15)

NFC-50/100: 120 VAC, 60 Hz, 3.5 amps.

NFC-50/100E: 240 VAC, 50 Hz, 2.0 amps.

Wire size: minimum #14 AWG (2.00mm²) with 600 V insulation.

SECONDARY POWER (BATTERY) CHARGING CIRCUIT (J7)

- Supports lead-acid batteries only.
- Float charge voltage at 27.3V
- Maximum charge current: 1.0 Amp
- Maximum battery charge capability: 2.8 Amps, 26AH (NFC cabinet holds max. 18AH battery).
- Minimum Battery size: 12 Amp Hour.

AC LOSS RELAY CONTACT RATING (TB3)

- 2.0 amps @ 30 VDC (resistive), 0.5 amps @ 30 VAC (resistive).

FORM C - TROUBLE RELAY CONTACT RATING (TB2)

- 2.0 amps @ 30 VDC (resistive), 0.5 amp @ 30 VAC (resistive).

MNS ACTIVE RELAY CONTACT RATING (TB1)

- 2.0 amps @ 30 VDC (resistive), 0.5 amps @ 30 VAC (resistive).

NOTIFICATION APPLIANCE CIRCUIT (NAC) OUTPUT RATING (TB19)

- One (1) Style Y (Class B) or Style Z (Class A) circuit.
- Power-limited circuitry, (Class 2) supervised.
- Nominal operating voltage: 24 VDC.
- Maximum signaling current for special application power: 2.0A.
- Maximum signaling current for regulated power: 200mA.
- Maximum wiring impedance: 1 Ω .
- Current limit: fuse-less, electronic, power-limited.
- End-Of-Line Resistor: 4.7 K Ω , ½ watt, (P/N 71252) required for Style Y (Class B) operation.

Refer to the Device Compatibility Document 15378 for listed compatible devices.

NAC FOLLOWER OUTPUT REMOTE SYNC (TB18)

- Connections for FACP NAC synchronization trigger signal.
- Output terminals: pass-through to other system components.
- Trigger input voltage: 9 to 32 VDC, 24 VDC rated.
- Input current draw in Alarm condition: 10 mA at rated voltage.

SPECIAL APPLICATION POWER (AUX. POWER) (TB17)

- 500 mA @ 24 VDC.
- Used for powering addressable modules and associated End-of-Line power supervision relays.

Power-limited circuitry. Refer to the Device Compatibility Document 15378 for a list of compatible devices.

SPEAKER VOLUME CONTROL OVERRIDE (TB23)

- Style Y (Class B) or Style Z (Class A) circuit.
- Special application power.
- Power-limited circuitry, supervised.
- Nominal operating voltage: 24 VDC.
- Maximum signaling current: 0.25 amps.
- Current limit: fuse-less, electronic, power-limited.

- End-Of-Line Resistor: 4.7 K Ω , ½ watt, (P/N 71252) required for Style Y (Class B) operation.

Speaker Circuits

- Primary Speaker Circuit (TB20)
- Secondary Speaker Circuit (TB21) (with optional amplifier only).
 - Circuit can be wired Style Y (Class B) or Style Z (Class A).
 - Power-limited circuitry.
 - Normal Operating Voltage: 25 VRMS @ 2 amps max and maximum Load Impedance of 12.5 Ω (70V @ 700 mA max. with maximum load Impedance of 100 Ω operation possible by plugging optional NFC-XRM-70V conversion transformer into J12 of the main control board).
 - Output Power: 50 watts (10 watts when background music is employed).
 - Frequency Range: 400Hz - 4,000Hz.
 - Maximum total capacitance for each speaker circuit: 250 μ F.
 - End-of-Line Resistor required for Style Y circuit: 15 K Ω , 1 watt (P/N: ELR-15K).

Command Input Circuits (alarm polarities shown)

CMD1 - TB4 Terminals 3(+) & 4(-) are input terminals and Terminals 1(-) and 2(+) are output terminals which provide feed through of the NAC circuits to NAC devices down stream.

CMD2 - TB5 Terminals 3(+) & 4(-) are input terminals and Terminals 1(-) and 2(+) are output terminals which provide feed through of the NAC circuits to NAC devices downstream.

CMD3 - TB6 Terminals 1(+) & 2(-) are input terminals for contact closure only.

CMD4 - TB6 Terminals 3(+) & 4(-) are input terminals for contact closure only.

CMD5 - TB7 Terminals 1(+) & 2(-) are input terminals for contact closure only.

CMD6 - TB7 Terminals 3(+) & 4(-) are input terminals for contact closure only.

CMD7 - TB8 Terminals 1(+) & 2(-) are input terminals for contact closure only.

CMD8 - TB8 Terminals 3(+) & 4(-) are input terminals for contact closure only.

- Power-limited and supervised circuitry.
- Normal Operating Voltage Range: 10.5 VDC - 29 VDC; (Maximum Voltage: 29 VDC).
- NAC Reverse Polarity Current (requires End-of-Line Resistor from NAC): 1.6 mA maximum.
- Contact Closure Operation Current (requires 4.7K Ω , ½ watt End-of-Line Resistor P/N 27072): 6.6 mA maximum.
- Maximum Wiring Impedance CMD1 - CMD8 (Contact Closure Operation): 200 Ω .

NOTE: When the system is programmed for Mass Notification, CMD1 and CMD2 will be programmed for Reverse Polarity only. See manual P/N LS10001-001NF-E for more details.

MAXIMUM INPUT IMPEDANCE:

- CMD1 & CMD2 (Reverse Polarity Operation): 20K Ω .
- CMD1 - CMD8 (Contact Closure Operation): 4.75K Ω .

NIGHT RING INPUT - TB16, TERMINALS 1 (+) & 2 (-)

- Contact closure input.
- Isolated, non-supervised.
- Operation current: 3.8 mA, maximum.

- Maximum wiring impedance: 30K Ω .
- Minimum isolation withstand voltage: 1500 VRMS.

EXTERNAL OPERATOR INTERFACE POWER OUTPUT (TB24)

- Non-resettable power for external operator interface components.
- Power-limited circuitry, non-supervised.
- Nominal operating voltage: 24 VDC.
- Maximum output current: 0.80 amps.
- Current limit: fuse-less, electronic, power-limited circuit.

EXTERNAL DATA BUS (EIA-485) (TB12)

- Data connections for external operator interface components.
- Redundant transceiver circuitry for Class A operability.
- Power-limited circuitry, supervised.
- Maximum wiring impedance: 13.2 Ω

FACP DATA BUS (EIA-485) (TB13)

- Dedicated connection to FACP serial bus.
- Output terminals: pass-through to other system components.
- Isolated, supervised.
- Minimum isolation withstand voltage: 1500 VRMS.
- Maximum wiring impedance: 40 Ω (ANN-BUS), 26 Ω (ACS-BUS).
- External Audio Riser (TB22).
- Style Y (Class B) or Style Z (Class A) audio connections to external operator interface components.
- Power-limited circuitry, supervised.
- Audio signal level: 3.85 V, maximum.
- Frequency range: 400 Hz - 4 KHz RMS.
- Frequency range (NFC-50/125DA): 800Hz - 2KHz RMS.

EXTERNAL AUDIO INPUT (TB5)

- Input Impedance: 8.5K Ω nominal @1KHz
- Input Voltage: 700 mV rms maximum
- Input Current: 0.1 mA maximum @ 700 mV

NOTE: Some laptops/personal computers only provide an audio output for headphones. It may be necessary to adjust the headphone output level for proper recording of voice messages.

NFC-CE6 Circuit Expander Module Specifications

- Power-limited circuitry.
- Up to six (6) circuits on the NFC-CE6 can be wired as Style Y (Class B) or Style Z (Class A).
- Normal Operating Voltage for Speaker Circuits: 25 V@ 2.0 amps max. (Maximum Load Impedance of 12.5 Ω).
- 70.0 V @ 700 mA max. with maximum Load Impedance of 100 Ω operation possible for the primary circuit by plugging in an optional NFC-XRM-70V conversion transformer into J12 of the main control board. The same operation is possible for the optional 50W amplifier by selecting the NFC-BDA-70V model.
- Speaker circuit wiring is supervised during standby, background music, and alarm.

- Output Power: 50 watts total; Frequency Range: 400Hz - 4,000Hz.
- Maximum total capacitance: 250 μ F. (Note that the total capacitance for the speaker outputs must not exceed the maximum of 250 μ F).
- End-of-Line Resistor required for Style Y (Class B) speaker circuit: 15 K Ω , 1 watt (P/N: ELR-15K) TB13 on the main control board: ACS/ANN (EIA-485) electrically isolated link to FACP provides programmed speaker control.

Cabinet Specifications

- Backbox: 19.0"(48.26 cm) high x 16.65"(42.29 cm) wide x 5.20"(13.23 cm) deep.
- Door: 19.26" (48.92 cm) high x 16.82"(42.73 cm) wide x 0.12"(0.30 cm) deep.
- Trim Ring (TR-CE-B): 22.00" (55.88 cm) high x 19.65" (49.91 cm) wide.

Shipping Specifications

Base Unit Weight: 27.85 lbs (12.63 kg).

Temperature and Humidity ranges

This system meets NFPA requirements for operation at 0-49° C/32-120° F and at a relative humidity 93% \pm 2% RH (non-condensing) at 32°C \pm 2°C (90°F \pm 3°F). However, the useful life of the system's standby batteries and the electronic components may be adversely affected by extreme temperature ranges and humidity. Therefore, it is recommended that this system and its peripherals be installed in an environment with a normal room temperature of 15-27° C/60-80° F.

Agency Listings and Approvals

The listings and approvals below apply to the basic NFC-50/100(E) control panel. In some cases, certain modules may not be listed by certain approval agencies or listing may be in process. Consult factory for latest listing status.

- UL/ULC Listed S635.
- Compliant with UFC 4-021-01.
- CSFM: 6911-0028:0265.
- NYC Fire Dept. Certificate of Approval: #6163

Standards and Codes

The NFC-50/100(E) complies with the following UL Standards, NFPA 72, International Building Codes, and California Building Codes.

- UL 864.
- UL 2572.
- IBC 2012, IBC 2009, IBC 2006, IBC 2003, IBC 2000 (Seismic).
- CBC 2007 (Seismic)

First Command® and Notifier® are registered trademarks of Honeywell International Inc.

©2015 by Honeywell International Inc. All rights reserved. Unauthorized use of this document is strictly prohibited.



This document is not intended to be used for installation purposes.
We try to keep our product information up-to-date and accurate.
We cannot cover all specific applications or anticipate all requirements.
All specifications are subject to change without notice.



Made in the U.S.A.

For more information, contact Notifier. Phone: (203) 484-7161, FAX: (203) 484-7118.

www.notifier.com

CALIFORNIA DEPARTMENT OF FORESTRY & FIRE PROTECTION
OFFICE OF THE STATE FIRE MARSHAL
FIRE ENGINEERING - BUILDING MATERIALS LISTING PROGRAM



LISTING SERVICE

Page 1 of 1

LISTING No. 6911-0028:0265

CATEGORY: 6911 -- VOICE COMMUNICATION SYSTEMS CONTROL UNITS

LISTEE: NotifierOne Fire-Lite Place, Northford, CT 06472-1653
Contact: Vladimir Kireyev (203) 484-6277 Fax (203) 484-7309
Email: vladimir.kireyev@honeywell.com

DESIGN: Models NFC-50/100 and NFC-50/100E. These are 50-watt audio emergency voice evacuation panels expandable to 100-watt for fire applications, mass notification applications, or both. Refer to listee's data sheet for additional detailed product description and operational considerations. System components:
*ECC-LOC; Local Operator Console
ECC-MCB; Main Control Board
ECC-DKVC; Display Board
NFC-BDA-25V; Amplifier Module 25 VRMS
NFC-BDA-70V; Amplifier Module 70 VRMS
NFC-CE6; Speaker Circuit Expander Module
NFC-XRM-70V; Transformer Module 70.7 VRMS

RATING: Primary Operating: 120 V, 60 Hz, 3.5 A or 240 V, 50 Hz, 2 A

INSTALLATION: In accordance with listee's printed installation instructions, applicable codes & ordinances and in a manner acceptable to the authority having jurisdiction.

MARKING: Listee's name, model number, electrical rating, and UL label.

APPROVAL: Listed as voice communication systems for use with separately listed compatible fire alarm control units to provide emergency voice evacuation signals. Refer to listee's Installation Instruction Manual for details.

XLF: 6911-0075:0226

*12-27-2016 dc



This listing is based upon technical data submitted by the applicant. CSFM Fire Engineering staff has reviewed the test results and/or other data but does not make an independent verification of any claims. This listing is not an endorsement or recommendation of the item listed. This listing should not be used to verify correct operational requirements or installation criteria. Refer to listee's data sheet, installation instructions and/or other

Date Issued: **July 01, 2018**

Listing Expires **June 30, 2019**

Authorized By: **DAVID CASTILLO**, Program Coordinator
Fire Engineering Division

NBG-12LX

Addressable Manual Pull Station

 **NOTIFIER**[®]
by Honeywell

Intelligent/Addressable Devices

General

The Notifier NBG-12LX is a state-of-the-art, dual-action (i.e., requires two motions to activate the station) pull station that includes an addressable interface for any Notifier intelligent control panel except FireWarden series panels, and the NSP-25 panel. Because the NBG-12LX is addressable, the control panel can display the exact location of the activated manual station. This leads fire personnel quickly to the location of the alarm.

Features

- Maintenance personnel can open station for inspection and address setting without causing an alarm condition.
- Built-in bicolor LED, which is visible through the handle of the station, flashes in normal operation and latches steady red when in alarm.
- Handle latches in down position and the word "ACTIVATED" appears to clearly indicate the station has been operated.
- Captive screw terminals wire-ready for easy connection to SLC loop (accepts up to 12 AWG/3.25 mm² wire).
- Can be surface mounted (with SB-10 or SB-I/O) or semi-flush mounted. Semi-flush mount to a standard single-gang, double-gang, or 4" (10.16 cm) square electrical box.
- Smooth dual-action design.
- Meets ADAAG controls and operating mechanisms guidelines (Section 4.1.3[13]); meets ADA requirement for 5 lb. maximum activation force.
- Highly visible.
- Attractive shape and textured finish.
- Key reset.
- Includes Braille text on station handle.
- Optional trim ring (BG12TR).
- Meets UL 38, Standard for Manually Actuated Signaling Boxes.
- Up to 99 NBG-12LX stations per loop on CLIP protocol loops.
- Up to 159 NBG-12LX stations per loop on FlashScan[®] protocol loops.
- Dual-color LED blinks green to indicate normal on FlashScan[®] systems.

Construction

Shell, door, and handle are molded of durable polycarbonate material with a textured finish.

Specifications

- **Shipping Weight:** 9.6 oz. (272.15 g)
- **Normal operating voltage:** 24 VDC.
- **Maximum SLC loop voltage:** 28.0 VDC.
- **Maximum SLC standby current:** 375 μ A.
- **Maximum SLC alarm current:** 5 mA.
- **Temperature Range:** 32°F to 120°F (0°C to 49°C)
- **Relative Humidity:** 10% to 93% (noncondensing)
- **For use indoors in a dry location**



The NBG-12LX
Addressable Manual Pull Station

Installation

The NBG-12LX will mount semi-flush into a single-gang, double-gang, or standard 4" (10.16 cm) square electrical outlet box, or will surface mount to the model SB-10 or SB-I/O surface backbox. If the NBG-12LX is being semi-flush mounted, then the optional trim ring (BG12TR) may be used. The BG12TR is usually needed for semi-flush mounting with 4" (10.16 cm) or double-gang boxes (not with single-gang boxes).

Operation

Pushing in, then pulling down on the handle causes it to latch in the down/activated position. Once latched, the word "ACTIVATED" (in bright yellow) appears at the top of the handle, while a portion of the handle protrudes from the bottom of the station. To reset the station, simply unlock the station with the key and pull the door open. This action resets the handle; closing the door automatically resets the switch.

Each manual station, on command from the control panel, sends data to the panel representing the state of the manual switch. Two rotary decimal switches allow address settings (1 – 159 on FlashScan[®] systems, 1 – 99 on CLIP systems).

Architectural/Engineering Specifications

Manual Fire Alarm Stations shall be non-coded, with a key-operated reset lock in order that they may be tested, and so designed that after actual Emergency Operation, they cannot be restored to normal except by use of a key. An operated station shall automatically condition itself so as to be visually detected as activated. Manual stations shall be constructed of red-colored polycarbonate material with clearly visible operating instructions provided on the cover. The word FIRE shall appear on the front of the stations in white letters, 1.00 inches (2.54 cm) or larger. Stations shall be suitable for surface mounting on matching backbox SB-10 or SB-I/O; or semi-flush mounting on a standard single-gang, double-gang, or

4" (10.16 cm) square electrical box, and shall be installed within the limits defined by the Americans with Disabilities Act (ADA) or per national/local requirements. Manual Stations shall be Underwriters Laboratories listed.

Manual stations shall connect with two wires to one of the control panel SLC loops. The manual station shall, on command from the control panel, send data to the panel representing the state of the manual switch. Manual stations shall provide address setting by use of rotary decimal switches.

The loop poll LED shall be clearly visible through the front of the station. The LED shall flash while in the normal condition, and stay steadily illuminated when in alarm.

Product Line Information

NBG-12LX: Dual-action addressable pull station. Includes key locking feature. (Listed for Canadian and non-Canadian applications.)

NBG-12LXSP: Spanish/English labelled version.

NBG-12LXP: Portuguese labelled version.

SB-10: Surface backbox; metal.

SB-I/O: Surface backbox; plastic.

BG12TR: Optional trim ring.

17021: Keys, set of two.

NY-Plate: New York City trim plate.

Agency Listings and Approvals

In some cases, certain modules or applications may not be listed by certain approval agencies, or listing may be in process. Consult factory for latest listing status.

- **UL/ULC Listed:** S692 (listed for Canadian and non-Canadian applications).
- **MEA:** 67-02-E.
- **CSFM:** 7150-0028:0199.
- **FDNY:** COA #6085 (NFS2-640), COA #6098 (NFS2-3030).
- **BSMI:** CI313066760047.
- **U.S. Coast Guard.**
- **Lloyd's Register.**
- **FM Approved.**

Patented: U.S. Patent No. D428,351; 6,380,846; 6,314,772; 6,632,108.

NOTIFIER® and FlashScan® are registered trademarks of Honeywell International Inc.
©2012 by Honeywell International Inc. All rights reserved. Unauthorized use of this document is strictly prohibited.



This document is not intended to be used for installation purposes.
We try to keep our product information up-to-date and accurate.
We cannot cover all specific applications or anticipate all requirements.
All specifications are subject to change without notice.



Made in the U.S. A.

For more information, contact Notifier. Phone: (203) 484-7161, FAX: (203) 484-7118.
www.notifier.com

CALIFORNIA DEPARTMENT OF FORESTRY & FIRE PROTECTION
OFFICE OF THE STATE FIRE MARSHAL
FIRE ENGINEERING - BUILDING MATERIALS LISTING PROGRAM



LISTING SERVICE

LISTING No. 7150-0028:0199

Page 1 of 1

CATEGORY: 7150 -- FIRE ALARM PULL BOXES

LISTEE: NotifierOne Fire-Lite Place, Northford, CT 06472-1653
Contact: Vladimir Kireyev (203) 484-6277 Fax (203) 484-7309
Email: vladimir.kireyev@honeywell.com

DESIGN: Models NBG-12, NBG-12S, NBG-12LR, NBG-12LRA, NBG-12LAO, NBG-12LAOB, NBG-12-LO, NBG-12LOB, NBG-12W, NBG-12LW, NBG-12NC, NBG-12WP, NBG-12LWP, NBG-12L, NBG-12LX, NBG-12LA, NBG-12PS, NBG-12LSP, NBG-12LPS, NBG-12LPSP, NBG-12SP, NOT-BG12LX, NBG-12LXSP, NBG-12LXBL and NBG-12LXP fire alarm pull boxes. All units except Model NBG-12S are dual action pull stations. Models NBG-12LR and NBG-12LRA are intended for agent releasing device. Refer to listee's data sheet for detailed product description and operational considerations.

INSTALLATION: In accordance with listee's printed installation instructions, applicable codes and ordinances and in a manner acceptable to the authority having jurisdiction.

MARKING: Listee's name, model number, rating, and UL label.

APPROVAL: Listed as fire alarm pull boxes for use with separately listed compatible fire alarm control units. Models NBG-12WP, NBG-12LW, NBG-12W, NBG-12LWP, NBG-12LAO, NBG-12LO, NBG-12LAOB and NBG-12LOB are intended for outdoor use when installed with Models WBB, SB-I/O, or WP-10 back box. Refer to listee's Installation Instruction Manual for details.

These manual pull boxes meet the requirements of UL Standard 38, 1999 Edition and California amendments which the controls and operating mechanisms required to be operable at no more than 5lbs. force with one hand and shall not require tight grasping, pinching, or twisting of the wrist.

*Corrected 10-08-12 bh



This listing is based upon technical data submitted by the applicant. CSFM Fire Engineering staff has reviewed the test results and/or other data but does not make an independent verification of any claims. This listing is not an endorsement or recommendation of the item listed. This listing should not be used to verify correct operational requirements or installation criteria. Refer to listee's data sheet, installation instructions and/or other

Date Issued: **July 01, 2018**

Listing Expires **June 30, 2019**

Authorized By: **DAVID CASTILLO**, Program Coordinator
Fire Engineering Division

IPGSM-4G

Single or Dual Path Commercial Fire Communicator

General

The IPGSM-4G is a commercial fire alarm communicator that offers contact ID reporting with any Fire Alarm Control Panel (FACP) that has a built-in dialer. This *single or dual path* communicator connects directly to the primary and secondary communication ports of a fire panel's Digital Alarm Communicator Transmitter (DACT). It offers three selectable reporting paths which include: Cellular only, IP only, or IP primary/cellular backup. All signals from the IPGSM-4G are delivered to Honeywell's AlarmNet® Network Control Center, which routes highly encrypted Ethernet data packets via a customer provided internet connection or cellular network to the appropriate central station. The state of the art AlarmNet network control center is fully redundant and monitored 24/7. AlarmNet has the ability to route messages using AlarmNet-I and 800 PLUS services, providing true redundancy and multi-path message delivery.

Alternative communication methods are critical in the marketplace due to VoIP (Voice over IP), migration from POTS (Plain Old Telephone Service) and growth of digital radio networks. The IPGSM-4G's single path communications solution allows one technology to be used (either IP or cellular) to provide the appropriate connectivity to a central station. For added reliability, our exclusive dual path solution allows both technologies (IP and cellular) to be used together for maximum survivability or for local jurisdiction requirements that specify a dual technology system.



FEATURES & BENEFITS

- Saves the cost of two dedicated phone lines.
- Single or dual path communications— (can communicate to central station using cellular technology, internet, or both).
- Requires no change to the existing Fire Alarm Control Panel configuration. (Connects directly to the primary and secondary telephone ports of a DACT.)
- Operates over the following communication protocols: HSPA+ (4G) HSPA (HSDPA & HSUPA) (3G), EDGE (2G GPRS) (2G).
- Selectable reporting paths and supervision intervals to meet NFPA 72, chapter 26 requirements. (Compliant with NFPA 72 2010 and 2013 supervision requirements.)
- Works over any type of customer provided Ethernet 10/100 based network connection (LAN or WAN), DSL modem or cable modem.
- Data transmits over standard contact-ID protocol but is secured with the industry's advanced encryption standard (AES 256 bit).
- Supports both dynamic (DHCP) or Public and Private Static IP addressing.
- Built-In Power Supply module: On board charging circuit design accommodates back-up battery. Includes primary power and battery supervision.
- Diagnostic LEDs: Signal strength and status indicators.
- Reliable connection: IP and GSM connection tested every day.
- QOS: Quality of Service diagnostics via AlarmNet conveys vital communicator information including when message was received, signal strength, and message path used.
- 7720P Hand-held programmer for easy setup.

The IPGSM-4G is designed to operate over the most common cellular networks, including 3G and HSPA+. Its multi-GSM platform technology automatically chooses the best available cellular signal in the area based on signal strength and seamlessly self-adjusts to maintain critical life safety communication. In addition, it connects to any type of customer provided Ethernet 10/100 base network connection (LAN or WAN), DSL model or cable modem. Our selectable reporting path feature allows the radio to be configured for a single or dual path solution as well as the appropriate supervision intervals based on NFPA 72 requirements. (See diagram below for selectable paths and supervision timing intervals.)

| Selectable Path | Description | Supervision Times |
|-----------------|-----------------------------|-------------------|
| 2010 GSM | Single Path (cellular only) | 5 minutes |
| 2010 IP | Single Path (IP only) | 5 minutes |
| 2010 IP & GSM | Dual Path (IP and cellular) | 24 hours |
| 2013 GSM | Single Path (cellular only) | 1 hour |
| 2013 IP | Single Path (IP only) | 1 hour |
| 2013 IP & GSM | Dual Path (IP and cellular) | 6 hours |

Operation

When an event occurs, the Fire Alarm Control Panel goes off hook to dial the central station. The IPGSM-4G Dialer Capture Module detects the off-hook condition and provides the fire panel with a dial tone. When the fire panel detects the dial tone, it begins dialing the central station. After the dialing is completed, the Dialer Capture Module returns a handshake to the fire panel. The fire panel then sends the contact ID reports to the Dialer Capture Module, which in turn sends a kiss-off after the report is successfully received from the fire panel. The Dialer Capture Module sends the contact ID reports to the IPGSM communications module. When all the reports are sent, the fire panel goes on-hook. The IPGSM communications module then transmits the messages to the central station either over the GSM network or the Internet (dependent on configuration).

Easy to Program

The IPGSM-4G communicator can be pre-programmed using the 7720P programmer to enter all central-station information. This is saved to the IPGSM-4G communicator panel memory. When the IPGSM-4G communicator is installed at the site and connected to the Internet/Intranet, it registers itself with the AlarmNet receiver.

For most installations, the only required parameters are:

- Primary City ID (two digits) obtained from your monitoring station.
- Primary Central Station ID (two digits) obtained from your monitoring station.
- Primary Subscriber ID (four digits) obtained from your monitoring station.
- Communication Module's MAC ID, and MAC CRC number located on outside of box, and inside of the module.

All of these parameters are assigned by the monitoring station.

Note: Some assembly is required. See Installation and Setup Guide #800-12454 for full details.

Fire Communicator Capability

The IPGSM-4G is compatible with fire panels that use the Contact ID communications format as described in the SIA DC-05 standard.

AlarmNet

Honeywell's AlarmNet has been the nationwide leader in alarm communications technology since 1986. A reliable alternative for the transmission of alarm signals, our radio network provides extensive coverage in the United States and Canada. AlarmNet Network Control center processes signals from powerful servers in multiple locations equipped with 24/7 infrastructure support. The AlarmNet network consist of redundant hardware servers, hot back-up databases and generators with battery back-up at all locations to ensure continuity of service. Signals from Alarm-Net are transmitted to the central station's receivers using multiple communications paths consisting of the Internet, radio network or toll-free POTS service.

Installation Requirements

UL COMPLIANCE

To meet UL864/NFPA, ensure the following:

- IPGSM-4G must be installed in accordance with NFPA (National Fire Protection Association) standards 70 and 72.
- IPGSM-4G must be mounted in the same room and within 20 feet of the fire panel.
- IPGSM-4G, and all equipment used for the IP connection (such as the router, hub, modem, etc.) shall be listed, must be powered from an un-switched branch circuit, and be provided with appropriate standby power.
- IPGSM-4G must use the 7AH battery (not supplied) to provide 24-hour backup capability.

IPGSM-4G Technical Specifications

ELECTRICAL

Transformer:

Primary: 120VAC, 60Hz, 0.5A

Secondary: 18VDC, 50VA

Battery:

One 12 V 7.0 AH lead-acid battery: (not supplied)

Battery charging current: 1 Amp maximum

Battery discharge current: Standby 230mA, Active 950mA

CABINET SPECIFICATIONS

Dimensions: 14.875" H x 12.75" W x 3.0" D (37.8 cm H x 32.4 cm W x 7.6 cm D)

Color: Red

SHIPPING SPECIFICATIONS

Weight: 5.3 lbs. (6.94 kg)

Dimensions: 15.625" H x 13.79" W x 9.25" D (39.7 cm H x 34.9 cm W x 23.9 cm D)

TEMPERATURE AND HUMIDITY RANGES

This system meets NFPA requirements for operation at 0 - 49°C/32 - 120°F and at a relative humidity 93% ± 2% RH (non condensing at 32°C ± 2°C (90°F ± 3°F)). However, the useful life of the system's standby batteries and the electronic components may be adversely affected by extreme temperature ranges and humidity. Therefore, it is recommended that this system and its peripherals be installed in an environment with a normal room temperature of 15 - 27°C/60 - 80°F.

PRODUCT LINE INFORMATION

IPGSM-4G: Internet and Digital Cellular Fire Alarm Communicator Panel. Includes red cabinet with Ademco® key and lock, wall outlet box, Dialer Capture Module, IGSM Communications Module, antenna & mounting adapter, PowerBoost1 power supply, LED display board, transformer, manual, & required screws, cables, etc.

Antenna External Hardware

GSM-ANT3DB: 3db gain external/remote antenna

WA7626-CA: SMA to N Adapter

7626-50HC: 50 ft. antenna cable, low loss

7626-25HC: 25 ft. antenna cable, low loss

Note: The GSM-ANT3DB and the WA7626-CA are both required for installing an external antenna along with the necessary cable needed (7626-50HC: 50 ft. or 7626-25HC: 25 ft.)

Other Accessories

7720P: IPGSM-4G hand held programmer.

HPTCOVER: Plug-in transformer box for IPGSM communicator.

BAT-1270: Battery 12 Volts, 7 AH, sealed.

AGENCY LISTINGS AND APPROVALS

The listings and approvals below apply to the basic IPGSM-4G communicator panel. In some cases, certain modules may not be listed by certain approval agencies, or listing may be in process.

Consult factory for latest listing status.

UL Listed: S789

CSFM: 7300-1645:0199

FDNY: COA #6219

Ademco® and AlarmNet® are registered trademarks of Honeywell International Inc.

This document is not intended to be used for installation purposes. We try to keep our product information up-to-date and accurate. We cannot cover all specific applications or anticipate all requirements. All specifications are subject to change without notice.

For more information

Learn more about Honeywell's IPGSM-4G and other products available by visiting www.honeywellpower.com.

Honeywell Power Products

12 Clintonville Road
Northford, CT 06472-1610
877.HPP.POWR
www.honeywell.com

DH-60769 | F | 06/17
©2017 Honeywell International Inc.

Honeywell
THE POWER OF CONNECTED

CALIFORNIA DEPARTMENT OF FORESTRY & FIRE PROTECTION
OFFICE OF THE STATE FIRE MARSHAL
FIRE ENGINEERING - BUILDING MATERIALS LISTING PROGRAM



LISTING SERVICE

LISTING No. 7300-1645:0199

Page 1 of 1

CATEGORY: 7300 -- FIRE ALARM CONTROL UNIT ACCESSORIES/MISC. DEVICES

LISTEE: HONEYWELL SECURITY2 Corporate Center Dr, Ste. 100, Melville, NY 11747
Contact: Issa Khouryawa (516) 577-2312 Fax (516) 577-3540
Email: issa.khouryawa@Honeywell.com

DESIGN: Models iPGSM-COM, iPGSM-DP, iPGSM-4G and *IGSMCFP4G Internet and Digital Cellular Fire Communicators. Units are suitable for residential and commercial applications. Refer to listee's data sheet for detailed product description and operational considerations.

INSTALLATION: In accordance with listee's printed installation instructions, applicable codes & ordinances and in a manner acceptable to the authority having jurisdiction.

MARKING: Listee's name, model number, electrical rating, and UL label.

APPROVAL: Listed as a control unit accessory for use with separately listed compatible commercial and residential fire alarm control units. *Model IGSMCFP4G is intended for use with specific Honeywell Security control units that employ the ECP bus. Refer to listee's installation Instruction Manual for details.

NOTE: Burglary and other non-fire functions were not examined.

iPGSM-COM, iPGSM-DP formerly listed in 7300-1645:0183.

*Rev 07-01-14 gt



This listing is based upon technical data submitted by the applicant. CSFM Fire Engineering staff has reviewed the test results and/or other data but does not make an independent verification of any claims. This listing is not an endorsement or recommendation of the item listed. This listing should not be used to verify correct operational requirements or installation criteria. Refer to listee's data sheet, installation instructions and/or other

Date Issued: **July 01, 2018**

Listing Expires **June 30, 2019**

Authorized By: **DAVID CASTILLO**, Program Coordinator

Fire Engineering Division

FSP-851(A) Series

Intelligent Plug-In Photoelectric Smoke Detectors with FlashScan®

 **NOTIFIER®**
by Honeywell

Intelligent/Addressable Devices

General

Notifier FSP-851(A) Series intelligent plug-in smoke detectors with integral communication provide features that surpass conventional detectors. Detector sensitivity can be programmed in the control panel software. Sensitivity is continuously monitored and reported to the panel. Point ID capability allows each detector's address to be set with rotary, decimal address switches, providing exact detector location for selective maintenance when chamber contamination reaches an unacceptable level. The FSP-851(A) photoelectric detector's unique optical sensing chamber is engineered to sense smoke produced by a wide range of combustion sources. Dual electronic thermistors add 135°F (57°C) fixed-temperature thermal sensing on the FSP-851T(A). The FSP-851R(A) is a remote test capable detector for use with DNR(A)/DNRW duct detector housings. FSP-851(A) series detectors are compatible with Notifier Onyx and CLIP series Fire Alarm Control Panels (FACPs).

FlashScan® (U.S. Patent 5,539,389) is a communication protocol developed by Notifier that greatly increases the speed of communication between analog intelligent devices. Intelligent devices communicate in a grouped fashion. If one of the devices in the group has new information, the panel's CPU stops the group poll and concentrates on single points. The net effect is response speed greater than five times that of earlier designs.

Features

- Sleek, low-profile design.
- Addressable-analog communication.
- Stable communication technique with noise immunity.
- Low standby current.
- Two-wire SLC connection.
- Compatible with FlashScan® and CLIP protocol systems.
- Rotary, decimal addressing (1-99 on CLIP systems, 1-159 on FlashScan systems).
- Optional remote, single-gang LED accessory.
- Dual LED design provides 360° viewing angle.
- Visible bi-color LEDs blink green every time the detector is addressed, and illuminate steady red on alarm (*FlashScan systems only*).
- Remote test feature from the panel.
- Walk test with address display (an address on 121 will blink the detector LED: 12-[pause]-1 (*FlashScan systems only*)).
- Built-in functional test switch activated by external magnet.
- Built-in tamper-resistant feature.
- Sealed against back pressure.
- Constructed of off-white fire-resistant plastic, designed to commercial standards, and offers an attractive appearance.
- 94-5V plastic flammability rating.
- SEMS screws for wiring of the separate base.
- Optional relay, isolator, and sounder bases.



FSP-851(A) in B210LP(A) Base

B210-29651.jpg

Specifications

Sensitivity: 0.5% to 2.35% per foot obscuration

Size: 2.1" (5.3 cm) high; base determines diameter.

- **B210LP(A):** 6.1" (15.5 cm) diameter.
- **B501(A):** 4.1" (10.4 cm) diameter.
- **B200S(A):** 6.875" (17.46 cm) diameter.
- **B200SR(A):** 6.875" (17.46 cm) diameter.
- **B224RB(A):** 6.2" (15.748 cm) diameter.
- **B224BI(A):** 6.2" (15.748 cm) diameter.

Shipping Weight: 5.2oz. (147g).

Operating Temperature range: FSP-851(A), 0°C to 49°C (32°F to 120°F). FSP-851T(A), 0°C to 38°C (32°F to 100°F). Low temperature signal for FSP-851T(A) at 45°F +/- 10°F (7.22°C +/- 5.54°C). FSP-851R(A) installed in a DNR(A)/DNRW, -20°C to 70°C (-4°F to 158°F).

UL/ULC Listed Velocity Range: 0-4000 ft/min. (1219.2 m/min.), suitable for installation in ducts.

Relative Humidity: 10%-93% noncondensing.

Thermal Ratings: Fixed-temperature setpoint 135°F (57°C).

DETECTOR SPACING AND APPLICATIONS

Notifier recommends spacing detectors in compliance with NFPA 72. In low airflow applications with smooth ceiling, space detectors 30 feet (9.144m) for ceiling heights 10 feet (3.148m) and higher. For specific information regarding detector spacing, placement, and special applications refer to NFPA 72. *System Smoke Detector Application Guide*, document A05-1003, is available at systemsensor.com

ELECTRICAL SPECIFICATIONS

Voltage Range: 15-32 volts DC peak.

Standby Current (max. avg.): 300µA @ 24VDC (one communication every five seconds with LED enabled).

LED Current (max.): 6.5mA @ 24 VDC ("ON").

Installation

FSP-851(A) plug-in detectors use a separate base to simplify installation, service, and maintenance. A special tool allows maintenance personnel to plug in and remove detectors without using a ladder.

Mount base (all base types) on an electrical backbox which is at least 1.5" (3.81 cm) deep. For a chart of compatible junction boxes, see *DN-60054*.

NOTE: 1) Because of inherent supervision provided by the SLC loop, end-of-line resistors are not required. Wiring "T-taps" or branches are permitted for Style 4 (Class "B") wiring. 2) When using relay or sounder bases, consult the ISO-X(A) installation sheet I56-1380 for device limitations between isolator modules and isolator bases.

Agency Listings and Approvals

These listings and approvals apply to the modules specified in this document. In some cases, certain modules or applications may not be listed by certain approval agencies, or listing may be in process. Consult factory for latest listing status.

- **UL Listed:** S1115.
- **ULC Listed:** S1115 (FSP-851A, FSP-851RA, FSP-851TA).
- **MEA Listed:** 225-02-E .
- **FM Approved.**
- **CSFM:** 7272-0028:0206 .
- **Maryland State Fire Marshal:** Permit # 2122 .
- **BSMI:** CI313066760036.
- **CCCF:** Certif. # 2004081801000017 (FSP-851T) Certif. # 2004081801000016 (FSP-851).
- **U.S. Coast Guard:** 161.002/42/1 (NFS-640); 161.002/50/0 (NFS2-640/NFS-320/NFS-320C, excluding B210LP(A)).
- **Lloyd's Register:** 11/600013 (NFS2-640/NFS-320/NFS-320C, excluding B210LP(A)).

Product Line Information

NOTE: "A" suffix indicates ULC Listed model.

FSP-851: Low-profile intelligent photoelectric sensor. Must be mounted to one of the bases listed below.

FSP-851A: Same as FSP-851 but with ULC listing.

FSP-851T: Same as FSP-851 but includes a built-in 135°F (57°C) fixed-temperature thermal device.

FSP-851TA: Same as FSP-851T but with ULC listing.

FSP-851R: Low-profile intelligent photoelectric sensor, remote test capable. For use with DNRA/DNRW.

FSP-851RA: Same as FSP-851R but with ULC listing. For use with DNRA.

INTELLIGENT BASES

NOTE: "A" suffix indicates ULC Listed model.

NOTE: For details on intelligent bases, see *DN-60054*.

B210LP(A): Standard U.S. flanged low-profile mounting base.

B210LPBP: Bulk pack of B210LP; package contains 10.

B501(A): Standard European flangeless mounting base.

B501BP: Bulk pack of B501; package contains 10.

B200S(A): Intelligent, programmable sounder base capable of producing sound output in high or low volume with ANSI Temporal 3, ANSI Temporal 4, continuous tone, marching tone, and custom tone.

B200SR(A): Intelligent sounder base capable of producing sound output with ANSI Temporal 3 or continuous tone. Replaces B501BH series bases in retrofit applications.

B224RB(A): Plug-in System Sensor **relay** base. Screw terminals: up to 14 AWG (2.0 mm²). Relay type: Form-C. Rating: 2.0 A @ 30 VDC resistive; 0.3 A @ 110 VDC inductive; 1.0 A @ 30 VDC inductive.

B224BI(A): Plug-in System Sensor **isolator** detector base. Maximum 25 devices between isolator bases.

ACCESSORIES

F110: Retrofit flange to convert B210LP(A) to match the B710LP(A) profile, or to convert older high-profile bases to low-profile.

F110BP: Bulk pack of F110; package contains 15.

F210: Replacement flange for B210LP(A) base.

RA100Z(A): Remote LED annunciator. 3 – 32 VDC. Mounts to a U.S. single-gang electrical box. For use with B501(A) and B210LP(A) bases only.

SMB600: Surface mounting kit

M02-04-00: Test magnet.

M02-09-00: Test magnet with telescoping handle.

XR2B: Detector removal tool. Allows installation and/or removal of detector heads from bases in high ceiling applications.

XP-4: Extension pole for XR2B. Comes in three 5-foot (1.524 m) sections.

T55-127-010: Detector removal tool without pole.

BCK-200B: Black detector covers for use with FSP-851(A) only; box of 10.

WCK-200B: White detector covers for use with FSP-851(A) only; box of 10.

NOTIFIER® is a registered trademark of Honeywell International Inc. ©2015 by Honeywell International Inc. All rights reserved. Unauthorized use of this document is strictly prohibited.



This document is not intended to be used for installation purposes. We try to keep our product information up-to-date and accurate. We cannot cover all specific applications or anticipate all requirements. All specifications are subject to change without notice.

For more information, contact Notifier. Phone: (203) 484-7161, FAX: (203) 484-7118.
www.notifier.com

CALIFORNIA DEPARTMENT OF FORESTRY & FIRE PROTECTION
OFFICE OF THE STATE FIRE MARSHAL
FIRE ENGINEERING - BUILDING MATERIALS LISTING PROGRAM



LISTING SERVICE

LISTING No. 7272-0028:0206
CATEGORY: 7272 -- SMOKE DETECTOR-SYSTEM TYPE-PHOTOELECTRIC

Page 1 of 1

LISTEE: NotifierOne Fire-Lite Place, Northford, CT 06472-1653
Contact: Vladimir Kireyev (203) 484-6277 Fax (203) 484-7309
Email: vladimir.kireyev@honeywell.com

DESIGN: Models FSP-751, HPX-751, FSP-751T, FSH-751, FAPT-751, FAPT-851, FSP-851, FSP-851R* and FSP-851T photoelectric type smoke detectors. Models FSP-751T and FSP-851T employ a 135°F supplement integral heat sensor which only assists in a fire situation. This thermal circuitry is NOT approved for use in lieu of a required heat detector. Refer to listee's data sheet for additional detailed product description and operational considerations.

RATING: 24 VDC

INSTALLATION: In accordance with listee's printed installation instructions, applicable codes & ordinances and in manner acceptable to the authority having jurisdiction.

MARKING: Listee's name, product number, electrical rating and UL label.

APPROVAL: Listed as photoelectric type smoke detector for use with listee's separately listed compatible base and fire alarm control units. Models FSP-751, FSP-751T, FAPT-751, FAPT-851, FSP-851, FSP-851R*, FSP-851T are suitable for open areas and inside duct installation with air velocities between 0-4000 fpm. Model HPX-751 is suitable for open areas with air velocities between 0-300 fpm. Model FSH-751 is suitable for open areas with air velocity between 0-4000 fpm.

NOTE: Combined with 7272-0028:208

The photoelectric type detectors are generally more effective at detecting slow, smoldering fires that smolder for hours before bursting into flame. Sources of these fires may include cigarettes burning in couches or bedding. The ionization type detectors are generally more effective at detecting fast, flaming fires that consume combustible materials rapidly and spread quickly. Sources of these fires may include paper burning in a waste container or a grease fire in the kitchen.

*Rev. 01-07-2009 fm



This listing is based upon technical data submitted by the applicant. CSFM Fire Engineering staff has reviewed the test results and/or other data but does not make an independent verification of any claims. This listing is not an endorsement or recommendation of the item listed. This listing should not be used to verify correct operational requirements or installation criteria. Refer to listee's data sheet, installation instructions and/or other

Date Issued: **July 01, 2018**

Listing Expires **June 30, 2019**

Authorized By: **DAVID CASTILLO**, Program Coordinator
Fire Engineering Division

FST-851(A) Series

Intelligent Thermal (Heat) Detectors with FlashScan®

 **NOTIFIER®**
by Honeywell

Intelligent / Addressable Devices

General

Notifier FST-851(A) Series intelligent plug-in thermal detectors with integral communication has features that surpass conventional detectors. Point ID capability allows each detector's address to be set with rotary, decimal address switches, providing exact detector locations. FST-851(A) Series thermal detectors use an innovative thermistor sensing circuit to produce 135°F/57°C fixed-temperature (FST-851/A) and rate-of-rise thermal detection (FST-851R/A) in a low-profile package. FST-851H(A) provides fixed high-temperature detection at 190°F/88°C. These thermal detectors provide effective, intelligent property protection in a variety of applications. FST-851(A) Series detectors are compatible with Notifier Onyx and CLIP series Fire Alarm Control Panels (FACPs).

FlashScan® (U.S. Patent 5,539,389) is a communication protocol developed by Notifier Engineering that greatly enhances the speed of communication between analog intelligent devices and certain NOTIFIER systems. Intelligent devices communicate in a grouped fashion. If one of the devices within the group has new information, the panel's CPU stops the group poll and concentrates on single points. The net effect is response speed greater than five times that of earlier designs.

Features

- Sleek, low-profile, stylish design.
- State-of-the-art thermistor technology for fast response.
- Rate-of-rise model (FST-851R/A), 15°F (8.3°C) per minute.
- Factory preset fixed temperature at 135°F (57°C); high-temperature model fixed at 190°F (88°C).
- Addressable by device.
- Compatible with FlashScan® and CLIP protocol systems.
- Rotary, decimal addressing (1-99 on CLIP systems, 1-159 on FlashScan systems).
- Two-wire SLC connection.
- Visible LEDs "blink" every time the unit is addressed.
- 360°-field viewing angle of the visual alarm indicators (two bi-color LEDs). LEDs blink green in Normal condition and turn on steady red in Alarm.
- Integral communications and built-in device-type identification.
- Remote test feature from the panel.
- Built-in functional test switch activated by external magnet.
- Walk test with address display (an address of 121 will blink the detector LED 12-(pause)-1).
- Low standby current.
- Backward-compatible.
- Built-in tamper-resistant feature.
- Designed for direct-surface or electrical-box mounting.
- Sealed against back pressure.
- Plugs into separate base for ease of installation and maintenance. Separate base allows interchange of photoelectric, ionization and thermal sensors.
- SEMS screws for wiring of the separate base.
- Constructed of off-white fire-resistant plastic, designed to commercial standards, and offers an attractive appearance.



FST-851(A) in B210LP(A) Base

B210-2251.jpg

- 94-5V plastic flammability rating.
- Remote LED output connection to optional RA100Z(A) remote LED annunciator.
- Optional sounder, relay, and isolator bases.
- Optional flanged surface mounting kit.

Specifications

Size: 2.1" (5.3 cm) high; base determines diameter.

- **B210LP(A):** 6.1" (15.5 cm) diameter.
- **B501(A):** 4.1" (10.4 cm) diameter.
- **B200S(A):** 6.875" (17.46 cm) diameter.
- **B200SR(A):** 6.875" (17.46 cm) diameter.
- **B224RB(A):** 6.2" (15.748 cm) diameter.
- **B224BI(A):** 6.2" (15.748 cm) diameter.

Shipping weight: 4.8 oz. (137 g).

Operating temperature range: FST-851(A) Series, FST-851R(A): -20°C to 38°C (-4°F to 100°F); FST-851H(A): -20°C to 66°C (-4°F to 150°F).

Detector spacing: UL approved for 50 ft. (15.24 m) center to center. FM approved for 25 x 25 ft. (7.62 x 7.62 m) spacing.

Relative humidity: 10% – 93% noncondensing.

Thermal ratings: fixed-temperature setpoint 135°F (57°C), rate-of-rise detection 15°F (8.3°C) per minute, high temperature heat 190°F (88°C).

ELECTRICAL SPECIFICATIONS

Voltage range: 15 - 32 volts DC peak.

Standby current (max. avg.): 300 µA @ 24 VDC (one communication every 5 seconds with LED enabled).

LED current (max.): 6.5 mA @ 24 VDC ("ON").

Applications

Use thermal detectors for protection of property. For further information, go to systemsensor.com for manual I56-407-00, Applications Manual for System Smoke Detectors, which provides detailed information on detector spacing, placement, zoning, wiring, and special applications.

Installation

The FST Series plug-in intelligent thermal detectors use a separate base to simplify installation, service, and maintenance. Installation instructions are shipped with each detector. A special tool allows maintenance personnel to plug in and remove detectors without using a ladder.

Mount base (all base types) on an electrical backbox which is at least 1.5" (3.81 cm) deep. For a chart of compatible junction boxes, see DN-60054.

NOTE: 1) Because of the inherent supervision provided by the SLC loop, end-of-line resistors are not required. Wiring "T-taps" or branches are permitted for Style 4 (Class "B") wiring. **2)** When using relay or sounder bases, consult the ISO-X(A) installation sheet I56-1380 for device limitations between isolator modules and isolator bases.

Agency Listings and Approvals

These listings and approvals apply to the modules specified in this document. In some cases, certain modules or applications may not be listed by certain approval agencies, or listing may be in process. Consult factory for latest listing status.

- **UL Listed:** S747.
- **ULC Listed:** S6978.
- **MEA Listed:** 383-02-E.
- **FM Approved.**
- **CSFM:** 7270-0028:0196.
- **BSMI:** C1313066760025.
- **CCCF:** Certif. # 2004081801000018.
- **U.S. Coast Guard:** 161.002/42/1 (NFS-640); 161.002/50/0 (NFS2-640/NFS-320/NFS-320C, excluding B210LP(A)).
- **Lloyd's Register:** 11/600013 (NFS2-640/NFS-320/NFS-320C, excluding B210LP(A)).

Product Line Information

NOTE: "A" suffix indicates ULC Listed model.

FST-851: Intelligent thermal detector. Must be mounted to one of the bases listed below.

FST-851A: Same as FST-851 but with ULC Listing.

FST-851R: Intelligent thermal detector with rate-of-rise feature.

FST-851RA: Same as FST-851R but with ULC Listing.

FST-851H: Intelligent high-temperature thermal detector.

FST-851HA: Same as FST-851H but with ULC Listing.

INTELLIGENT BASES

NOTE: "A" suffix indicates ULC Listed model.

NOTE: For details about intelligent bases and their mounting, see DN-60054.

B210LP(A): Standard U.S. flanged low-profile mounting base.

B210LPBP: Bulk pack of B210LP; package contains 10.

B501(A): Standard European flangeless mounting base.

B501BP: Bulk pack of B501; package contains 10.

B200S(A): Addressable Intelligent, programmable sounder base capable of producing sound output in high or low volume

with ANSI Temporal 3, ANSI Temporal 4, continuous tone, marching tone, and custom tone.

B200SR(A): Intelligent sounder base capable of producing sound output with ANSI Temporal 3 or continuous tone. Replaces B501BH series bases in retrofit applications.

B224RB(A): Intelligent relay base. Screw terminals: up to 14 AWG (2.0 mm²). Relay type: Form-C. Rating: 2.0 A @ 30 VDC resistive; 0.3 A @ 110 VDC inductive; 1.0 A @ 30 VDC inductive.

B224BI(A): Intelligent isolator base. Isolates SLC from loop shorts. Maximum: 25 devices between isolator bases; see Note 2 under Installation.

ACCESSORIES

F110: Retrofit flange to convert B210LP(A) to match the B710LP(A) profile, or to convert older high-profile bases to low-profile.

F110BP: Bulk pack of F110; package contains 15.

F210: Replacement flange for B210LP(A) base.

RA100Z(A): Remote LED annunciator. 3 – 32 VDC. Fits U.S. single-gang electrical box. Supported by B210LP(A) and B501(A) bases only.

SMB600: Surface mounting kit, flanged.

M02-04-00: Test magnet.

M02-09-00: Test magnet with telescoping handle.

XR2B: Detector removal tool. Allows installation and/or removal of FlashScan® Series detector heads from base in high ceiling installations. Includes T55-127-010.

T55-127-010: Detector removal tool without pole.

XP-4: Extension pole for XR2B. Comes in three 5-foot (1.524 m) sections.

Notifier® and FlashScan® are registered trademarks of Honeywell International Inc.

©2011 by Honeywell International Inc. All rights reserved. Unauthorized use of this document is strictly prohibited.



This document is not intended to be used for installation purposes.
We try to keep our product information up-to-date and accurate.
We cannot cover all specific applications or anticipate all requirements.
All specifications are subject to change without notice.



Made in the U.S.A.

For more information, contact Notifier. Phone: (203) 484-7161, FAX: (203) 484-7118.

www.notifier.com

CALIFORNIA DEPARTMENT OF FORESTRY & FIRE PROTECTION
OFFICE OF THE STATE FIRE MARSHAL
FIRE ENGINEERING - BUILDING MATERIALS LISTING PROGRAM



LISTING SERVICE

LISTING No. 7270-0028:0196

Page 1 of 1

CATEGORY: 7270 -- HEAT DETECTOR

LISTEE: NotifierOne Fire-Lite Place, Northford, CT 06472-1653
Contact: Vladimir Kireyev (203) 484-6277 Fax (203) 484-7309
Email: vladimir.kireyev@honeywell.com

DESIGN: Models FST-751, -851, -851R, -851H (fixed temperature) and FST-751R (fixed temperature with Rate-of-Rise) electronic heat detectors. Refer to listee's data sheet for additional detailed product description and operational considerations.

RATING: Models FST-751, -751R, -851, and -851R = 135°F fixed temperature
Model FST-851H = 190°F fixed temperature

INSTALLATION: In accordance with listee's printed installation instructions, applicable codes and ordinances and in a manner acceptable to the authority having jurisdiction.

MARKING: Listee's name, model number, electrical ratings, and UL label.

APPROVAL: Listed as heat detectors for use with Models B501, *B210LP (CSFM Listing No. 7300-1653:0109), or B710LP base (CSFM Listing No. 7300-0028:173) and separately listed compatible fire alarm control units. Refer to listee's Installation Instructions Manual for details.

*11-22-2016 dc



This listing is based upon technical data submitted by the applicant. CSFM Fire Engineering staff has reviewed the test results and/or other data but does not make an independent verification of any claims. This listing is not an endorsement or recommendation of the item listed. This listing should not be used to verify correct operational requirements or installation criteria. Refer to listee's data sheet, installation instructions and/or other

Date Issued: **July 01, 2018**

Listing Expires **June 30, 2019**

Authorized By: **DAVID CASTILLO**, Program Coordinator
Fire Engineering Division

FMM-1(A), FMM-101(A), FZM-1(A) & FDM-1(A)

Monitor Modules with FlashScan®

 **NOTIFIER®**
by Honeywell

Intelligent/Addressable Devices

General

Four different monitor modules are available for Notifier's intelligent control panels for a variety of applications. Monitor modules supervise a circuit of dry-contact input devices, such as conventional heat detectors and pull stations, or monitor and power a circuit of two-wire smoke detectors (FZM-1(A)).

FMM-1(A) is a standard-sized module (typically mounts to a 4" [10.16 cm] square box) that supervises either a Style D (Class A) or Style B (Class B) circuit of dry-contact input devices.

FMM-101(A) is a miniature monitor module a mere 1.3" (3.302 cm) H x 2.75" (6.985 cm) W x 0.5" (1.270 cm) D that supervises a Style B (Class B) circuit of dry-contact input devices. Its compact design allows the FMM-101(A) to be mounted in a single-gang box behind the device it monitors.

FZM-1(A) is a standard-sized module that monitors and supervises compatible two-wire, 24 volt, smoke detectors on a Style D (Class A) or Style B (Class B) circuit.

FDM-1(A) is a standard-sized dual monitor module that monitors and supervises two independent two-wire Style B (Class B) dry-contact initiating device circuits (IDCs) at two separate, consecutive addresses in intelligent, two-wire systems.

FlashScan® (U.S. Patent 5,539,389) is a communication protocol developed by NOTIFIER that greatly increases the speed of communication between analog intelligent devices. Intelligent devices communicate in a grouped fashion. If one of the devices within the group has new information, the panel CPU stops the group poll and concentrates on single points. The net effect is response speed greater than five times that of other designs.

FMM-1(A) Monitor Module

- Built-in type identification automatically identifies this device as a monitor module to the control panel.
- Powered directly by two-wire SLC loop. No additional power required.
- High noise (EMF/RFI) immunity.
- SEMS screws with clamping plates for ease of wiring.
- Direct-dial entry of address: 01 – 159 on FlashScan loops; 01 – 99 on CLIP loops.
- LED flashes green during normal operation (this is a programmable option) and latches on steady red to indicate alarm.

The FMM-1(A) Monitor Module is intended for use in intelligent, two-wire systems, where the individual address of each module is selected using the built-in rotary switches. It provides either a two-wire or four-wire fault-tolerant Initiating Device Circuit (IDC) for normally-open-contact fire alarm and supervisory devices. The module has a panel-controlled LED indicator. The FMM-1(A) can be used to replace MMX-1(A) modules in existing systems.

FMM-1(A) APPLICATIONS

Use to monitor a zone of four-wire smoke detectors, manual fire alarm pull stations, waterflow devices, or other normally-open dry-contact alarm activation devices. May also be used to monitor normally-open supervisory devices with special supervisory indication at the control panel. Monitored circuit may be wired as an NFPA Style B (Class B) or Style D (Class

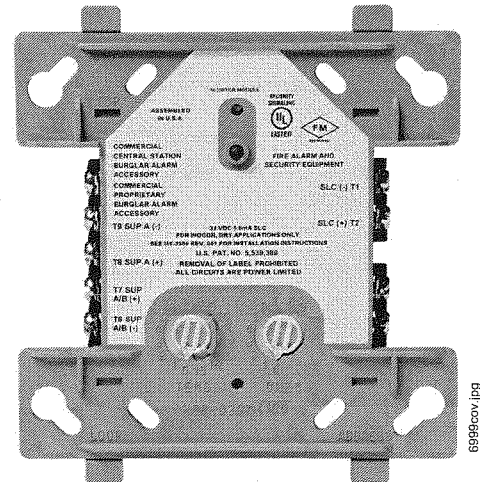

FMM-1(A) (Type H)

A) Initiating Device Circuit. A 47K ohm End-of-Line Resistor (provided) terminates the Style B circuit. No resistor is required for supervision of the Style D circuit.

FMM-1(A) OPERATION

Each FMM-1(A) uses one of the available module addresses on an SLC loop. It responds to regular polls from the control panel and reports its type and the status (open/normal/short) of its Initiating Device Circuit (IDC). A flashing LED indicates that the module is in communication with the control panel. The LED latches steady on alarm (subject to current limitations on the loop).

FMM-1(A) SPECIFICATIONS

Nominal operating voltage: 15 to 32 VDC.

Maximum current draw: 5.0 mA (LED on).

Average operating current: 350 μ A (LED flashing), 1 communication every 5 seconds, 47k EOL.

Maximum IDC wiring resistance: 40 ohms.

EOL resistance: 47K ohms.

Temperature range: 32°F to 120°F (0°C to 49°C).

Humidity range: 10% to 93% noncondensing.

Dimensions: 4.5" (11.43 cm) high x 4" (10.16 cm) wide x 1.25" (3.175 cm) deep. Mounts to a 4" (10.16 cm) square x 2.125" (5.398 cm) deep box.

FMM-101(A) Mini Monitor Module

- Built-in type identification automatically identifies this device as a monitor module to the panel.
- Powered directly by two-wire SLC loop. No additional power required.
- High noise (EMF/RFI) immunity.
- Tinned, stripped leads for ease of wiring.
- Direct-dial entry of address: 01 – 159 on FlashScan loops; 01 – 99 on CLIP loops.

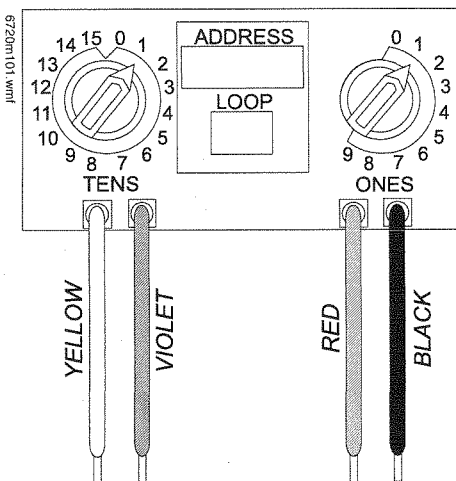

The FMM-101(A) Mini Monitor Module can be installed in a single-gang junction directly behind the monitored unit. Its small size and light weight allow it to be installed without rigid mounting. The FMM-101(A) is intended for use in intelligent, two-wire systems where the individual address of each module is selected using rotary switches. It provides a two-wire initiating device circuit for normally-open-contact fire alarm and security devices. The FMM-101(A) can be used to replace MMX-101(A) modules in existing systems.

FMM-101(A) APPLICATIONS

Use to monitor a single device or a zone of four-wire smoke detectors, manual fire alarm pull stations, waterflow devices, or other normally-open dry-contact devices. May also be used to monitor normally-open supervisory devices with special supervisory indication at the control panel. Monitored circuit/device is wired as an NFPA Style B (Class B) Initiating Device Circuit. A 47k ohm End-of-Line Resistor (provided) terminates the circuit.

FMM-101(A) OPERATION

Each FMM-101(A) uses one of the available module addresses on an SLC loop. It responds to regular polls from the control panel and reports its type and the status (open/normal/short) of its Initiating Device Circuit (IDC).

FMM-101(A) SPECIFICATIONS

Nominal operating voltage: 15 to 32 VDC.

Average operating current: 350 μ A, 1 communication every 5 seconds, 47k EOL; 600 μ A Max. (Communicating, IDC Shorted).

Maximum IDC wiring resistance: 40 ohms.

Maximum IDC Voltage: 11 Volts.

Maximum IDC Current: 400 μ A.

EOL resistance: 47K ohms.

Temperature range: 32°F to 120°F (0°C to 49°C).

Humidity range: 10% to 93% noncondensing.

Dimensions: 1.3" (3.302 cm) high x 2.75" (6.985 cm) wide x 0.65" (1.651 cm) deep.

Wire length: 6" (15.24 cm) minimum.

FZM-1(A) Interface Module

- Supports compatible two-wire smoke detectors.
- Supervises IDC wiring and connection of external power source.
- High noise (EMF/RFI) immunity.
- SEMS screws with clamping plates for ease of wiring.
- Direct-dial entry of address: 01 – 159 on FlashScan loops, 01 – 99 on CLIP loops.
- LED flashes during normal operation; this is a programmable option.
- LED latches steady to indicate alarm on command from control panel.

The FZM-1(A) Interface Module is intended for use in intelligent, addressable systems, where the individual address of each module is selected using built-in rotary switches. This module allows intelligent panels to interface and monitor two-wire conventional smoke detectors. It transmits the status (normal, open, or alarm) of one full zone of conventional detectors back to the control panel. All two-wire detectors being monitored must be UL compatible with the module. The FZM-1(A) can be used to replace MMX-2(A) modules in existing systems.

FZM-1(A) APPLICATIONS

Use the FZM-1(A) to monitor a zone of two-wire smoke detectors. The monitored circuit may be wired as an NFPA Style B (Class B) or Style D (Class A) Initiating Device Circuit. A 3.9 K ohm End-of-Line Resistor (provided) terminates the end of the Style B or D (class B or A) circuit (maximum IDC loop resistance is 25 ohms). Install ELR across terminals 8 and 9 for Style D application.

FZM-1(A) OPERATION

Each FZM-1(A) uses one of the available module addresses on an SLC loop. It responds to regular polls from the control panel and reports its type and the status (open/normal/short) of its Initiating Device Circuit (IDC). A flashing LED indicates that the module is in communication with the control panel. The LED latches steady on alarm (subject to current limitations on the loop).

FZM-1(A) SPECIFICATIONS

Nominal operating voltage: 15 to 32 VDC.

Maximum current draw: 5.1 mA (LED on).

Maximum IDC wiring resistance: 25 ohms.

Average operating current: 300 μ A, 1 communication and 1 LED flash every 5 seconds, 3.9k eol.

EOL resistance: 3.9K ohms.

External supply voltage (between Terminals T3 and T4): DC voltage: 24 volts power limited. Ripple voltage: 0.1 Vrms maximum. Current: 90 mA per module maximum.

Temperature range: 32°F to 120°F (0°C to 49°C).

Humidity range: 10% to 93% noncondensing.

Dimensions: 4.5" (11.43 cm) high x 4" (10.16 cm) wide x 1.25" (3.175 cm) deep. Mounts to a 4" (10.16 cm) square x 2.125" (5.398 cm) deep box.

FDM1(A) Dual Monitor Module

The FDM-1(A) Dual Monitor Module is intended for use in intelligent, two-wire systems. It provides two independent two-wire initiating device circuits (IDCs) at two separate, consecutive addresses. It is capable of monitoring normally open contact fire alarm and supervisory devices; or either normally open or normally closed security devices. The module has a single panel-controlled LED.

NOTE: The FDM-1(A) provides two Style B (Class B) IDC circuits ONLY. Style D (Class A) IDC circuits are NOT supported in any application.

FDM-1(A) SPECIFICATIONS

Normal operating voltage range: 15 to 32 VDC.

Maximum current draw: 6.4 mA (LED on).

Average operating current: 750 μ A (LED flashing).

Maximum IDC wiring resistance: 1,500 ohms.

Maximum IDC Voltage: 11 Volts.

Maximum IDC Current: 240 μ A

EOL resistance: 47K ohms.

Maximum SLC Wiring resistance: 40 Ohms.

Temperature range: 32° to 120°F (0° to 49°C).

Humidity range: 10% to 93% (non-condensing).

Dimensions: 4.5" (11.43 cm) high x 4" (10.16 cm) wide x 2.125" (5.398 cm) deep.

FDM-1(A) AUTOMATIC ADDRESSING

The FDM-1(A) automatically assigns itself to two addressable points, starting with the original address. For example, if the FDM-1(A) is set to address "26", then it will automatically assign itself to addresses "26" and "27".

NOTE: "Ones" addresses on the FDM-1(A) are 0, 2, 4, 6, or 8 only. Terminals 6 and 7 use the first address, and terminals 8 and 9 use the second address.



CAUTION:

Avoid duplicating addresses on the system.

Installation

FMM-1(A), FZM-1(A), and FDM-1(A) modules mount directly to a standard 4" (10.16 cm) square, 2.125" (5.398 cm) deep, electrical box. They may also be mounted to the SMB500 surface-mount box. Mounting hardware and installation instructions are provided with each module. All wiring must conform to applicable local codes, ordinances, and regulations. These modules are intended for power-limited wiring only.

The FMM-101(A) module is intended to be wired and mounted without rigid connections inside a standard electrical box. All wiring must conform to applicable local codes, ordinances, and regulations.

Agency Listings and Approvals

In some cases, certain modules may not be listed by certain approval agencies, or listing may be in process. Consult factory for latest listing status.

- **UL:** S635
- **ULC:** S635
- **FM Approved**
- **CSFM:** 7300-0028:0219
- **MEA:** 457-99-E
- **U.S. Coast Guard:**

– 161.002/23/3 (AFP-200: FMM-1/-101, FZM-1)

– 161.002/42/1 (NFS-640: FMM-1/-101)

- **Lloyd's Register:**

– 03/60011/E1 (FMM-1/-101, FZM-1)

– 94/60004/E2 (AFP-200: except FDM-1)

– 02/60007 (NFS-640: FDM-1)

- **FDNY:** COA #6038 (NFS2-640, NFS-320), COA# 6058 (NFS2-3030)

Product Line Information

NOTE: "A" suffix indicates ULC-listed model.

FMM-1(A): Monitor module.

FMM-101(A): Monitor module, miniature.

FZM-1(A): Monitor module, two-wire detectors.

FDM-1(A): Monitor module, dual, two independent Class B circuits.

SMB500: Optional surface-mount backbox.

NOTE: See installation instructions and refer to the SLC Wiring Manual, PN 51253.

FlashScan® and NOTIFIER® are registered trademarks and FireWatch™ is a trademark of Honeywell International Inc.
©2010 by Honeywell International Inc. All rights reserved. Unauthorized use of this document is strictly prohibited.

ISO 9001
CERTIFIED
ENGINEERING & MANUFACTURING
QUALITY SYSTEMS

This document is not intended to be used for installation purposes.
We try to keep our product information up-to-date and accurate.
We cannot cover all specific applications or anticipate all requirements.
All specifications are subject to change without notice.



Made in the U.S. A.

For more information, contact Notifier. Phone: (203) 484-7161, FAX: (203) 484-7118.
www.notifier.com

FCM-1(A) & FRM-1(A) Series

Control and Relay Modules



Intelligent / Addressable Devices

General

FCM-1(A) Control Module: The FCM-1(A) Addressable Control Module provides Notifier intelligent fire alarm control panels a circuit for Notification Appliances (horns, strobes, speakers, etc.). Addressability allows the FCM-1(A) to be activated, either manually or through panel programming, on a select (zone or area of coverage) basis.

FRM-1(A) Relay Module: The FRM-1(A) Addressable Relay Module provides the system with a dry-contact output for activating a variety of auxiliary devices, such as fans, dampers, control equipment, etc. Addressability allows the dry contact to be activated, either manually or through panel programming, on a select basis.

FlashScan® (U.S. Patent 5,539,389) is a communication protocol developed by NOTIFIER Engineering that greatly enhances the speed of communication between analog intelligent devices. Intelligent devices communicate in a grouped fashion. If one of the devices within the group has new information, the panel CPU stops the group poll and concentrates on single points. The net effect is response speed greater than five times that of other designs.

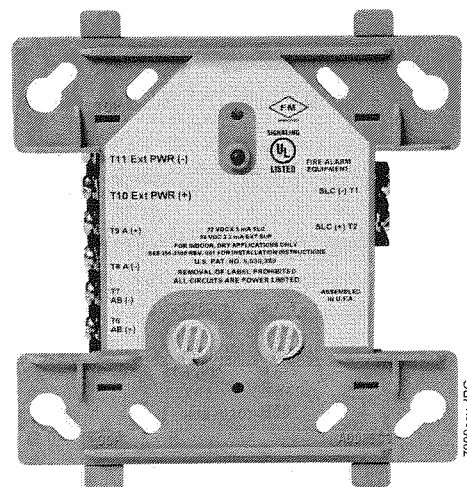

FCM-1(A)

Features

- Built-in type identification automatically identifies these devices to the control panel.
- Internal circuitry and relay powered directly by two-wire SLC loop. The FCM-1(A) module requires power (for horns, strobes, etc.), or audio (for speakers).
- Integral LED "blinks" green each time a communication is received from the control panel and turns on in steady red when activated.
- LED blink may be deselected globally (affects all devices).
- High noise immunity (EMF/RFI).
- The FCM-1(A) may be used to switch 24-volt NAC power, audio (up to 70.7 Vrms).
- Wide viewing angle of LED.
- SEMS screws with clamping plates for wiring ease.
- Direct-dial entry of address 01– 159 for FlashScan loops, 01 – 99 for CLIP mode loops.
- Speaker, and audible/visual applications may be wired for Class B or A (Style Y or Z).

Applications

The FCM-1(A) is used to switch 24 VDC audible/visual power, high-level audio (speakers). The FRM-1(A) may be programmed to operate dry contacts for applications such as door holders or Air Handling Unit shutdown, and to reset four-wire smoke detector power.

NOTE: Refer to the SLC Manual (PN 51253) for details regarding releasing applications with the FCM-1(A). Refer to the FCM-1-REL datasheet (DN-60390) for new FlashScan® releasing applications.

Construction

- The face plate is made of off-white heat-resistant plastic.
- Controls include two rotary switches for direct-dial entry of address (01-159).

- The FCM-1(A) is configured for a single Class B (Style Y) or Class A (Style Z) Notification Appliance Circuit.
- The FRM-1(A) provides two Form-C dry contacts that switch together.

Operation

Each FCM-1(A) or FRM-1(A) uses one of 159 possible module addresses on a SLC loop (99 on CLIP loops). It responds to regular polls from the control panel and reports its type and status, including the open/normal/short status of its Notification Appliance Circuit (NAC). The LED blinks with each poll received. On command, it activates its internal relay. The FCM-1(A) supervises Class B (Style Y) or Class A (Style Z) notification or control circuits.

Upon code command from the panel, the FCM-1(A) will disconnect the supervision and connect the external power supply in the proper polarity across the load device. The disconnection of the supervision provides a positive indication to the panel that the control relay actually turned ON. The external power supply is always relay isolated from the communication loop so that a trouble condition on the external power supply will never interfere with the rest of the system.

Rotary switches set a unique address for each module. The address may be set before or after mounting. The built-in TYPE CODE (not settable) will identify the module to the control panel, so as to differentiate between a module and a sensor address.

Specifications for FCM-1(A)

Normal operating voltage: 15 to 32 VDC.

Maximum current draw: 6.5 mA (LED on).

Average operating current: 350 μ A direct poll, 375 μ A group poll with LED flashing, 485 μ A Max. (LED flashing, NAC shorted.)

Maximum NAC Line Loss: 4 VDC.

External supply voltage (between Terminals T10 and T11): Maximum (NAC): Regulated 24 VDC; Maximum (Speakers): 70.7 V RMS, 50W.

Drain on external supply: 1.7 mA maximum using 24 VDC supply; 2.2 mA Maximum using 80 VRMS supply.

Max NAC Current Ratings: For class B wiring system, the current rating is 3A; For class A wiring system, the current rating is 2A.

Temperature range: 32°F to 120°F (0°C to 49°C).

Humidity range: 10% to 93% non-condensing.

Dimensions: 4.5" (114.3 mm) high x 4" (101.6 mm) wide x 1.25" (31.75 mm) deep. Mounts to a 4" (101.6 mm) square x 2.125" (53.975 mm) deep box.

Accessories: SMB500 Electrical Box; CB500 Barrier

Specifications for FRM-1(A)

Normal operating voltage: 15 to 32 VDC.

Maximum current draw: 6.5 mA (LED on).

Average operating current: 230 µA direct poll; 255 µA group poll.

EOL resistance: not used.

Temperature range: 32°F to 120°F (0°C to 49°C).

Humidity range: 10% to 93% non-condensing.

Dimensions: 4.5" (114.3 mm) high x 4" (101.6 mm) wide x 1.25" (31.75 mm) deep. Mounts to a 4" (101.6 mm) square x 2.125" (53.975 mm) deep box.

Accessories: SMB500 Electrical Box; CB500 Barrier

Agency Listings and Approvals

In some cases, certain modules may not be listed by certain approval agencies, or listing may be in process. Consult factory for latest listing status.

- **UL:** S635
- **ULC:** S3705 (A version only)
- **FM Approved**
- **CSFM:** 7300-0028:0219
- **MEA:** 14-00-E
- **FDNY:** COA #6067, #6065

Contact Ratings for FRM-1(A)

| Current Rating | Maximum Voltage | Load Description | Application |
|----------------|-----------------|---------------------|-------------|
| 3 A | 30 VDC | Resistive | Non-Coded |
| 2 A | 30 VDC | Resistive | Coded |
| .9 A | 110 VDC | Resistive | Non-Coded |
| .9 A | 125 VDC | Resistive | Non-Coded |
| .5 A | 30 VDC | Inductive (L/R=5ms) | Coded |
| 1 A | 30 VDC | Inductive (L/R=2ms) | Coded |
| .3 A | 125 VAC | Inductive (PF=0.35) | Non-Coded |
| 1.5 A | 25 VAC | Inductive (PF=0.35) | Non-Coded |
| .7 A | 70.7 VAC | Inductive (PF=0.35) | Non-Coded |
| 2 A | 25 VAC | Inductive (PF=0.35) | Non-Coded |

NOTE: Maximum (Speakers): 70.7 V RMS, 50 W

Product Line Information

NOTE: "A" suffix indicates ULC Listed model.

FCM-1(A): Intelligent Addressable Control Module.

FRM-1(A): Intelligent Addressable Relay Module.

A2143-20: Capacitor, required for Class A (Style Z) operation of speakers.

SMB500: Optional Surface-Mount Backbox.

CB500: Control Module Barrier — required by UL for separating power-limited and non-power limited wiring in the same junction box as FCM-1(A).

NOTE: For installation instructions, see the following documents:

- *FCM-1(A) Installation document I56-1169.*
- *FRM-1(A) Installation document I56-3502.*
- *Notifier SLC Wiring Manual, document 51253.*

Notifier® and FlashScan® are registered trademarks of Honeywell International Inc.
©2011 by Honeywell International Inc. All rights reserved. Unauthorized use of this document is strictly prohibited.



This document is not intended to be used for installation purposes.
We try to keep our product information up-to-date and accurate.
We cannot cover all specific applications or anticipate all requirements.
All specifications are subject to change without notice.



Made in the U.S. A.

For more information, contact Notifier. Phone: (203) 484-7161, FAX: (203) 484-7118.
www.notifier.com

CALIFORNIA DEPARTMENT OF FORESTRY & FIRE PROTECTION
OFFICE OF THE STATE FIRE MARSHAL
FIRE ENGINEERING - BUILDING MATERIALS LISTING PROGRAM



LISTING SERVICE

LISTING No. 7300-0028:0219 Page 1 of 1

CATEGORY: 7300 -- FIRE ALARM CONTROL UNIT ACCESSORIES/MISC. DEVICES

LISTEE: NotifierOne Fire-Lite Place, Northford, CT 06472-1653
Contact: Vladimir Kireyev (203) 484-6277 Fax (203) 484-7309
Email: vladimir.kireyev@honeywell.com

DESIGN: Models XP6-R relay module, XP6-C, supervising control module, XP10-M input monitor module, XP6-MA six zone interface module, FMM-1, FMM-101, FZM-1, FSM-101, FDM-1, FTM-1 monitor modules, FCM-1, FRM-1 control modules, and *FDRM-1 with 2 input/2 output relay module. All devices are intended to be connected between the signaling line circuit of a compatible fire alarm control panel. Refer to listee's data sheet for additional detailed product description and operational considerations.

RATING: 16-33 VDC Primary

INSTALLATION: In accordance with listee's printed installation instructions, applicable codes & ordinances and in manner acceptable to the authority having jurisdiction.

MARKING: Listee's name, product number and UL label.

APPROVAL: Listed as control unit accessories for use with listee's separately listed compatible fire alarm control units. Model FTM-1 is intended to be used with Notifier Models NFS-640, NFS2-640 (CSFM Listing No. 7165-0028:214), NFS-3030, NFS2-3030 (CSFM Listing No. 7165-0028:224) Fire Alarm Control Units.

NOTE: If an external power supply is used for Model XP6-MA, the negative of the external power supply is referenced to the negative of the auxiliary supply of the compatible control panel. This is done in order to detect ground faults on the initiating circuit.

*Rev. 10-24-11 mt



This listing is based upon technical data submitted by the applicant. CSFM Fire Engineering staff has reviewed the test results and/or other data but does not make an independent verification of any claims. This listing is not an endorsement or recommendation of the item listed. This listing should not be used to verify correct operational requirements or installation criteria. Refer to listee's data sheet, installation instructions and/or other

Date Issued: **July 01, 2018**

Listing Expires **June 30, 2019**

Authorized By: **DAVID CASTILLO**, Program Coordinator
Fire Engineering Division

Exceder Strobe, Horn Strobe, and Horn Notification Appliances



Description

The Wheelock Exceder Series of notification appliances feature a sleek modern design that will please building owners with reduced total cost of ownership. Installers will benefit from its comprehensive feature list, including the most candela options in one appliance, low current draw, no tools needed for setting changes, voltage test points, 12/24 VDC operation, universal mounting base and multiple mounting options for both new and retrofit construction.

The Wheelock Exceder Series incorporates high reliability and high efficiency optics to minimize current draw allowing for a greater number of appliances on the notification appliance circuit. All strobe models feature an industry first of 8 candela settings on a single appliance. Models with an audible feature 3 sound settings (90, 95, 99 dB). All switches to change settings, can be set without the use of a tool and are located behind the appliance to prevent tampering. Wall models feature voltage test points to take readings with a voltage meter for troubleshooting and AHJ inspection.

The Wheelock Exceder Series of wall and ceiling notification appliances feature a Universal Mounting Base (UMB) designed to simplify the installation and testing of horns, strobes, and combination horn strobes. The separate universal mounting base can be pre-wired to allow full testing of circuit wiring before the appliance is installed and the surface is finished. It comes complete with a Contact Cover for protection against dirt, dust, paint and damage to the contacts. The Contact Cover also acts as a shunting device to allow pre-wire testing for common wiring issues. The Contact Cover is polarized to prevent it from being installed incorrectly and prevents the appliance from being installed while it is on the UMB. When the Contact Cover is removed the circuit will show an open until the appliance is installed. The UMB allows for consistent installation and easy replacement of appliances if required. Wall models provide an optional locking screw for extra secure installation, while the ceiling models provide a captivated screw to prevent the screw from falling during installation.



Powering Business Worldwide

Features

- Sleek modern aesthetics
- Finger slide switches
- Voltage test points
- Multiple voltages
- 3 Audible settings
 - 90, 95, 99 dB
- Industry leading—8 candela settings on 1 device
 - Wall: 15/1575/30/75/95/110/135/185
 - Ceiling: 15/30/60/75/95/115/150/177



- Universal mounting base
 - Ceiling and wall
 - Mounts to 5 backbox types: 1 gang, 2 gang, 4" square, 3.5" octal. & 4" octal. (100mm for international customers)

Universal mounting base

Contact cover

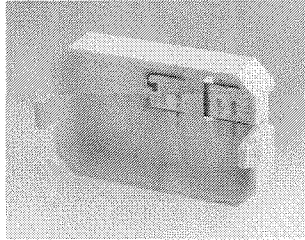
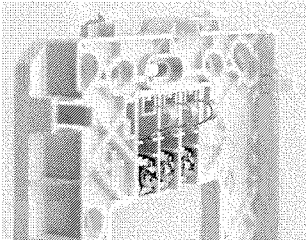

Common base for wall and ceiling with 5 mounting options

- Voltage test points for quick troubleshooting and easy spot checking (wall models only)

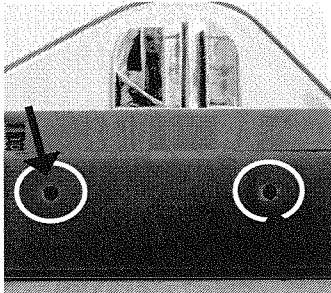

- Environmentally friendly
 - Low current draw
- Up to 9 models now in 1 appliance draw[Ⓞ]
- 12/24VDC on a single appliance
- Easy to remember model numbers

[Ⓞ] Patented

Note: Please read these specifications and associated installation instructions, before using, specifying, or installing this product. Visit Eaton.com/massnotification for current installation instructions.

General Notes

- Strobes are designed to flash at 1 flash per second minimum over their "Regulated Voltage Range."
- All candela ratings represent minimum effective strobe intensity based on UL Standard 1971.
- Series Exceder Strobe products are Listed under UL Standards 1971 and 464 for indoor use with a temperature range of 32°F to 120°F (0°C to 49°C) and maximum humidity of 93% (± 2%) UL 464 (85% UL 1971).
- Series Exceder horns are under UL Standard 464 for audible signal appliances (Indoor use only).

Compatibility and requirements

- Synchronize using the Wheelock[®] Sync Modules or panels with built-in Wheelock[®] Patented Sync Protocol
- Compatible with UL "Regulated Voltage" using filtered VDC or unfiltered VRMS input voltage
- Strobes produce 1 flash per second over the "Regulated Voltage" range

Compliance

- UL 1971, UL 464, ULC, CSFM, FM
- ADA/NFPA/ANSI/OSHA
- RoHS

Table 1. Strobe Ratings per UL Standard 1971

| Model | Regulated Voltage Range VDC | UL Max Current ^① | | | | | | | | | | | 12 VDC | | |
|-------|-----------------------------|-----------------------------|-------|-------|-------|-------|-------|-------|-------|-------|-------|-------|--------|-------|-------|
| | | 24 VDC / 24 FWR | | | | | | | | | | | 15 | 15/75 | |
| ST | 8.0-33.0 | 0.057 | 0.070 | 0.085 | — | 0.135 | 0.163 | 0.182 | — | 0.205 | — | — | 0.253 | 0.110 | 0.140 |
| STC | 8.0-33.0 | 0.061 | — | 0.085 | 0.103 | 0.135 | 0.163 | — | 0.182 | — | 0.205 | 0.253 | — | 0.110 | — |

Table 2. Horn Strobe Ratings per UL 1971 & Anechoic at 24 VDC

| Model | Regulated Voltage Range VDC | UL Max Current ^① at Anechoic 99 dBA | | | | | | | | | | | 12 VDC | | |
|-------|-----------------------------|--|-------|-------|-------|-------|-------|-------|-------|-------|-------|-------|--------|-------|-------|
| | | 24 VDC | | | | | | | | | | | 15 | 15/75 | |
| HS | 8.0-33.0 | 0.082 | 0.095 | 0.102 | — | 0.148 | 0.176 | 0.197 | — | 0.242 | — | — | 0.282 | 0.125 | 0.159 |
| HSC | 8.0-33.0 | 0.082 | — | 0.102 | 0.141 | 0.148 | 0.176 | — | 0.197 | — | 0.242 | 0.282 | — | 0.125 | — |

| Model | Regulated Voltage Range VDC | UL Max Current ^① at Anechoic 95 dBA | | | | | | | | | | | 12 VDC | | |
|-------|-----------------------------|--|-------|-------|-------|-------|-------|-------|-------|-------|-------|-------|--------|-------|-------|
| | | 24 VDC | | | | | | | | | | | 15 | 15/75 | |
| HS | 8.0-33.0 | 0.073 | 0.083 | 0.087 | — | 0.139 | 0.163 | 0.186 | — | 0.230 | — | — | 0.282 | 0.122 | 0.153 |
| HSC | 8.0-33.0 | 0.073 | — | 0.087 | 0.128 | 0.139 | 0.163 | — | 0.186 | — | 0.230 | 0.272 | — | 0.122 | — |

| Model | Regulated Voltage Range VDC | UL Max Current ^① at Anechoic 90 dBA | | | | | | | | | | | 12 VDC | | |
|-------|-----------------------------|--|-------|-------|-------|-------|-------|-------|-------|-------|-------|-------|--------|-------|-------|
| | | 24 VDC | | | | | | | | | | | 15 | 15/75 | |
| HS | 8.0-33.0 | 0.065 | 0.075 | 0.084 | — | 0.136 | 0.157 | 0.184 | — | 0.226 | — | — | 0.267 | 0.120 | 0.148 |
| HSC | 8.0-33.0 | 0.065 | — | 0.084 | 0.120 | 0.136 | 0.157 | — | 0.184 | — | 0.226 | 0.267 | — | 0.120 | — |

① UL max current rating is the maximum RMS current within the listed voltage range (16-33 VDC for 24 VDC units). For strobes the UL max current is usually at the minimum listed voltage (16 VDC for 24 VDC units). For audibles the max current is usually at the maximum listed voltage (33 VDC for 24 VDC units). For unfiltered ratings, see installation instructions.

Table 3. Horn Ratings per UL Anechoic

| Model | Regulated Voltage Range VDC | 99 dB | 95 dB | 90 dB |
|-------|-----------------------------|-------|-------|-------|
| HN | 16-33.0 | 0.064 | 0.044 | 0.022 |
| HNC | 16-33.0 | 0.084 | 0.044 | 0.022 |
| HN | 8.0-17.5 | 0.047 | 0.026 | 0.017 |
| HNC | 8.0-17.5 | 0.047 | 0.026 | 0.017 |

Table 4. Specification & Ordering Information

| Model | Strobe Candela | Sync w/ Wheelock Power Supplies | DSM or Power Supplies | 12/24 VDC ^① | Mounting Options |
|---------------------|------------------------------|---------------------------------|-----------------------|------------------------|------------------|
| Horn Strobes | | | | | |
| HSR | 15/1575/30/75/95/110/135/185 | X | | X | UMB ^② |
| HSW | 15/1575/30/75/95/110/135/185 | X | | X | UMB ^② |
| HSRC | 15/30/60/75/95/115/150/177 | X | | X | UMB ^② |
| HSWC | 15/30/60/75/95/115/150/177 | X | | X | UMB ^② |
| Strobes | | | | | |
| STR | 15/1575/30/75/95/110/135/185 | X | | X | UMB ^② |
| STW | 15/1575/30/75/95/110/135/185 | X | | X | UMB ^② |
| STRC | 15/30/60/75/95/115/150/177 | X | | X | UMB ^② |
| STWC | 15/30/60/75/95/115/150/177 | X | | X | UMB ^② |
| Horn | | | | | |
| HNR | | X | | X | UMB ^② |
| HNW | | X | | X | UMB ^② |
| HNRC | | X | | X | UMB ^② |
| HNWC | | X | | X | UMB ^② |

① 12 VDC models feature 15 & 15/75 settings

② UMB = Universal Mounting Base

Model Legend

| | |
|-------------------|-------------------------------------|
| HN = Horn | R = Red |
| ST = Strobe | A = Agent Lettering (strobes only) |
| HS = Horn Strobe | AL = Alert Lettering (strobes only) |
| C = Ceiling Mount | N = No Lettering (strobes only) |
| W = White | |

Example 1: STRC = Strobe, Red, Ceiling Mount
 Example 2: HSR = Horn Strobe, Red, Wall Mount
 Example 3: HSW = Horn Strobe, White, Wall Mount
 Example 4: STW-AL = Strobe, White, Wall Mount, Alert Lettering



Example: HSR



Example: HSWC

Architects and Engineers Specifications

The notification appliances shall be Wheelock Exceder Series HS Audible Strobe appliances, Series ST Visual Strobe appliances and Series HN Audible appliances or approved equals. The Series HS and ST Strobes shall be listed for UL Standard 1971 (Emergency Devices for the Hearing-Impaired) for Indoor Fire Protection Service. The Series HS and HN Audibles shall be UL Listed under Standard 464 (Fire Protective Signaling). All Series shall meet the requirements of FCC Part 15 Class B. All inputs shall be compatible with standard reverse polarity supervision of circuit wiring by a Fire Alarm Control Panel (FACP) with the ability to operate from 8 to 33 VDC. Indoor wall models shall incorporate voltage test points for easy voltage inspection.

The Series HS Audible Strobe and ST Strobe appliances shall produce a flash rate of one (1) flash per second over the Regulated Voltage Range and shall incorporate a Xenon flashtube enclosed in a rugged Lexan® lens. The Series shall be of low current design. Where multi-candela appliances are specified, the strobe intensity shall have 8 field selectable settings at 15, 15/75, 30, 75, 95, 110, 135, 185 candela for wall mount and 15, 30, 60, 75, 95, 115, 150, 177 candela for ceiling mount. The selector switch for selecting the candela shall be tamper resistant. The 15/75 candela strobe shall be specified when 15 candela UL Standard 1971 Listing with 75 candela on-axis is required (e.g., ADA compliance). Appliances with candela settings shall show the candela selection in a visible location at all times when installed.

The audible shall have a minimum of three (3) field selectable settings for dBA levels and shall have a choice of continuous or temporal (Code 3) audible outputs.

The Series HS Audible Strobe, ST Strobe and Series HN Audible shall incorporate a patented Universal Mounting Base that shall allow mounting to a single-gang, double-gang, 4-inch square, 3.5-inch octal, 4-inch octal or 100mm European type back boxes. Two wire appliance wiring shall be capable of directly connecting to the mounting base. Continuity checking of the entire NAC circuit prior to attaching any notification appliances shall be allowed. Product shall come with Contact Cover to protect contact springs. Removal of an appliance shall result in a supervision fault condition by the Fire Alarm Control Panel (FACP). The mounting base shall be the same base among all horn, strobe, horn strobe, wall and ceiling models. All notification appliances shall be backwards compatible.

The Series HS and ST wall models shall have a low profile measuring 5.24" H x 4.58" W x 2.19" D. Series HN wall shall measure 5.24" H x 4.58" W x 1.6" D. The Series HSC and STC shall be round and have a low profile with a diameter of 6.68" x 2.63" D. Series HNC ceiling shall have a diameter of 6.68" x 1.50" D.

When synchronization is required, the appliance shall be compatible with Wheelock's DSM Sync Modules, Wheelock Power Supplies or other manufacturer's panels with built-in Wheelock Patented Sync Protocol. The strobes shall not drift out of synchronization at any time during operation. If the sync protocol fails to operate, the strobe shall revert to a non-synchronized flash-rate and still maintain (1) flash per second over its Regulated Voltage Range. The appliance shall also be designed so that the audible signal may be silenced while maintaining strobe activation when used with Wheelock synchronization protocol.

Wall Appliances: UL Standard 1971, UL Standard 464, California State Fire Marshal (CSFM), ULC, FM, RoHS

Ceiling Appliances: UL Standard 1971, UL Standard 464, California State Fire Marshal (CSFM), ULC, FM, RoHS

Note: Due to continuous development of our products, specifications and offerings are subject to change without notice in accordance with Cooper Wheelock Inc., dba Eaton standard terms and conditions.



WE ENCOURAGE AND SUPPORT NICET CERTIFICATION
3 YEAR WARRANTY

Eaton
1000 Eaton Boulevard
Cleveland, OH 44122
United States
Eaton.com

Eaton
Life safety & mass notification solutions
273 Branchport Ave.
Long Branch, NJ 07740
Eaton.com/massnotification

© 2016 Eaton
All Rights Reserved
Printed in USA
Publication No. TD450049EN
November 2016

Eaton is a registered trademark.

All other trademarks are property of their respective owners.

CALIFORNIA DEPARTMENT OF FORESTRY & FIRE PROTECTION
OFFICE OF THE STATE FIRE MARSHAL
FIRE ENGINEERING - BUILDING MATERIALS LISTING PROGRAM



LISTING SERVICE

LISTING No. 7125-0785:0168

Page 1 of 1

CATEGORY: 7125 -- FIRE ALARM DEVICES FOR THE HEARING IMPAIRED

LISTEE: Cooper Wheelock Inc. 7246 16th St. E., Ste. 105, Sarasota, FL 34243
Contact: Tom Conover (941) 487-2336
Email: thomas.conover@cooperindustries.com

DESIGN: Exceder Series: Models ST strobe, HS horn strobe and HN horn. Model ST is a synchronous and non-synchronous strobe light. Model HS a visual/audible appliance and Model HN is an audible signal appliance. All units followed by R (red) or W (white). Additionally, a 'C' may be added for ceiling models and/or a '-NR' may be added for non-resettable models. For non -NR models and optional 'S' for silver fascia may be added*. Refer to listee's data sheet for additional detailed product description and operational considerations.

RATING: Electrical: 12 VDC/24VDC/FWR
Candela (wall)*: 15, 15/75, 30, 75, 95, 110, 135 & 185
Candela (ceiling)*: 15, 30, 60, 75, 95, 115, 150, & 177

INSTALLATION: In accordance with listee's printed installation instructions, applicable codes and ordinances and in a manner acceptable to the authority having jurisdiction. All models are for indoor use and for wall mount only or ceiling mount only*

MARKING: Listee's name, model number, electrical/candela rating, and UL label.

APPROVAL: Listed as horn for fire alarm signaling and strobe, horn/strobe for the hearing impaired when used with separately listed electrically compatible fire alarm control units. Refer to listee's Installation Instructions Manual for details.

*Rev. 9-24-09 fm



This listing is based upon technical data submitted by the applicant. CSFM Fire Engineering staff has reviewed the test results and/or other data but does not make an independent verification of any claims. This listing is not an endorsement or recommendation of the item listed. This listing should not be used to verify correct operational requirements or installation criteria. Refer to listee's data sheet, installation instructions and/or other

Date Issued: **July 01, 2018**

Listing Expires **June 30, 2019**

Authorized By: **DAVID CASTILLO**, Program Coordinator
Fire Engineering Division

Wheelock E70H & E90H High Fidelity Speakers & Speaker Strobes

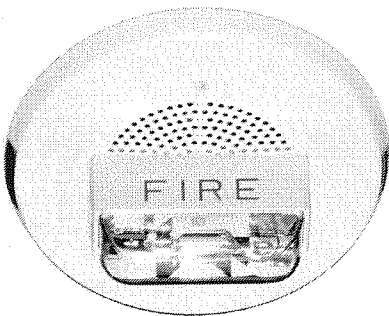
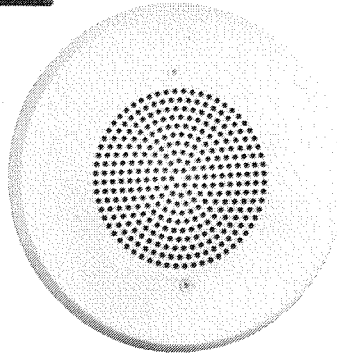
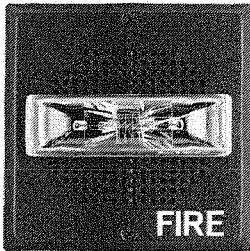

Description

The Wheelock E70H Wall and E90H Ceiling Speakers and Speaker Strobes are designed for high fidelity sound output for indoor applications. With the widest frequency response range (300 to 8000 Hz) in the industry, the EH features leading intelligibility with crisp, clear voice messages and tone signaling, ideal for emergency communications, mass notification, voice evacuation and fire alarm.

Providing a sleek aesthetic appearance, the Wheelock Series EH High Fidelity Speakers and Speaker Strobes feature dual voltage (25/70 VRMS) capability and field selectable taps from 1/8 to 2 watts. The low profile design incorporates a speaker mounting plate for faster and easier installation. Each model has a built-in level adjustment feature and an aesthetic two (2) screw grille cover.

For visible signaling to meet the hearing impaired, the EH Speaker Strobe models incorporate the Low Current draw RSS Strobes. Strobe options for wall mount models include 1575 or Wheelock patented MCW multi-candela strobe with field selectable candela settings of 15/30/75/110cd or the high intensity MCWH strobe with field selectable 135/185cd.

Ceiling mount models are available in Wheelock patented MCC multi-candela ceiling strobe with field selectable intensities of 15/30/75/95cd or the high intensity MCCH strobe with field selectable 115/177cd.

The strobe portion of all EH Speaker Strobes may be synchronized when used in conjunction with the Wheelock DSM Sync Modules, Wheelock Power Supplies or other manufacturers panels incorporating the Wheelock Patented Sync Protocol. Wheelock synchronized strobes offer an easy way to comply with ADA recommendations concerning photosensitive epilepsy.

The EH Speaker Strobes are UL Listed for indoor use under Standard 1971 (Signaling Devices for the Hearing-Impaired) and Standard 1480 (Speaker Appliances), and ULC listed under CAN/ULC-S526 (Visual-audible Signal Appliances, Fire Alarm) and under CAN/ULC-S541 (Speakers, Fire Alarm). All inputs employ IN/OUT wiring terminals for fast installation using #12 to #18 AWG wiring.

Color options for the EH Speakers and Speaker Strobes are red and white.



Powering Business Worldwide

Features

- High Fidelity Sound Output
 - Efficient design for high intelligibility at minimum wattage across a frequency range of 300 to 8000 HZ
- 6 Field Selectable Settings
 - Wall mount models are available with Field Selectable Candela Settings of 15/30/75/110cd or 135/185cd (Multi-Candela models) or 1575cd (Single Candela model)
 - Ceiling mount models are available with field selectable candela settings of 15/30/75/95cd or 115/177cd (Multi-candela models)
- Field Selectable Taps
 - 1/8 watt up to 2 watts
 - 25 or 70 VRMS operation
- Easy-to-Install
 - Low profile design incorporates speaker mounting plate for faster and easier installation
 - Built-in level adjustment feature and an aesthetic two (2) screw grille cover.
 - Quick installation with IN/OUT screw terminals using #12 to #18 AWG wires
 - 4" square backbox prevents wire damage
- Strobe Synchronization Components
 - Meet synchronizing standards with Wheelock's DSM Sync Modules, PS Power Supplies or SAFEPATH products
- Compliance
 - UL 1971, UL 1480, ULC-S526, ULC-S541
 - Low frequency requirements of UL 464 (520 Hz) to meet NFPA's 520 Hz tone requirements for sleeping areas
 - California State Fire Marshal (CSFM)
 - ADA/NFPA/ANSI/OSHA
 - FCC Part 15, ICES

Note: All CAUTIONS and WARNINGS are identified by the symbol ▲. All warnings are printed in bold capital letters.

▲ WARNING

PLEASE READ THESE SPECIFICATIONS AND ASSOCIATED INSTALLATION INSTRUCTIONS CAREFULLY BEFORE USING, SPECIFYING OR APPLYING THIS PRODUCT. VISIT WWW.EATON.COM/MASSNOTIFICATION OR CONTACT EATON FOR THE CURRENT INSTALLATION INSTRUCTIONS. FAILURE TO COMPLY WITH ANY OF THESE INSTRUCTIONS, CAUTIONS OR WARNINGS COULD RESULT IN IMPROPER APPLICATION, INSTALLATION AND/OR OPERATION OF THESE PRODUCTS IN AN EMERGENCY SITUATION, WHICH COULD RESULT IN PROPERTY DAMAGE, AND SERIOUS INJURY OR DEATH TO YOU AND/OR OTHERS.

Drawings

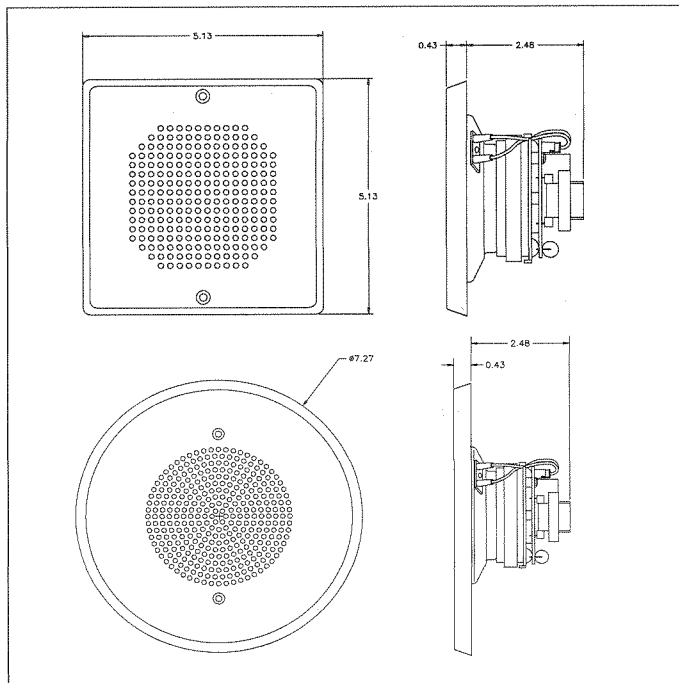

Figure 1. E70H (top) and E90H (bottom) Speakers - Front & Side Views

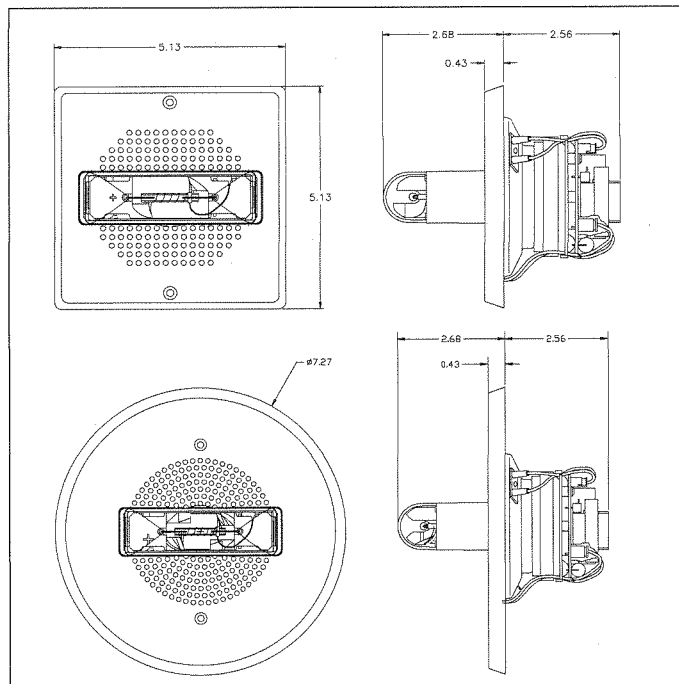

Figure 2. E70H (top) and E90H (bottom) Speaker Strobes - Front & Side Views

General Notes

- Strobes are designed to flash at 1 flash per second minimum over their "Regulated Voltage Range." Note that NFPA-72 specifies a flash rate of 1 to 2 flashes per second and ADA Guidelines specify a flash rate of 1 to 3 flashes per second.
- All candela ratings represent minimum effective Strobe intensity based on UL 1971.

Table 1. Maximum RMS Current

| Model | Regulated Voltage Range VDC | Table 1: Maximum RMS Current - Series E70H | | | | | Table 2: Maximum RMS Current - Series E90H | | | | |
|-------|-----------------------------|--|-------|---------------|-------|-------|--|-------|---------|-------|-------|
| | | 24MCW/24MCC | | 24MCWH/24MCCH | | | 241575W | | 241575W | | |
| | | 15 | 30 | 75 | 95 | 110 | 115 | 135 | 177 | 185 | 15/75 |
| E70H | 16.0-33.0 | 0.060 | 0.092 | 0.165 | | 0.220 | | 0.300 | | 0.420 | 0.090 |
| E90H | 16.0-33.0 | 0.065 | 0.105 | 0.189 | 0.249 | | 0.300 | | 0.420 | | |

Table 2. UL Listed Models and Ratings

| Model | UL Reverberant dBA at 10 Feet ^b | | | | |
|---------------------|--|-----------|-----------|---------|---------|
| | 1/8 watts ^c | 1/4 watts | 1/2 watts | 1 watts | 2 watts |
| E70H Speaker | 72 | 75 | 78 | 81 | 83 |
| E90H Speaker | 72 | 75 | 78 | 81 | 82 |
| E70H Speaker Strobe | 71 | 75 | 78 | 81 | 83 |
| E90H Speaker Strobe | 74 | 77 | 80 | 82 | 85 |

Table 3. Specification & Ordering Information

| Model | Order # | Strobe Candela | Red | White | Lettering | Wall | Ceiling | Mounting Options | Sync w/ DSM or Wheelock Power Supplies |
|------------------------|---------|----------------|-----|-------|--------------|------|---------|------------------|--|
| Speakers | | | | | | | | | |
| E70H-R | 9865 | | X | | No Lettering | X | | P, Q | |
| E70H-W | 9866 | | | X | No Lettering | X | | P, Q | |
| E90H-R | 9875 | | X | | No Lettering | | X | P, Q | |
| E90H-W | 9876 | | | X | No Lettering | | X | P, Q | |
| Speaker Strobes | | | | | | | | | |
| E70H-24MCW-FR | 0183 | 15/30/75/110 | X | | FIRE | X | | P, Q | X |
| E70H-24MCW-FW | 0184 | 15/30/75/110 | | X | FIRE | X | | P, Q | X |
| E70H-24MCWH-FR | 0185 | 135/185 | X | | FIRE | X | | P, Q | X |
| E70H-24MCWH-FW | 0186 | 135/185 | | X | FIRE | X | | P, Q | X |
| E90H-24MCC-FR | 0191 | 15/30/75/95 | X | | FIRE | | X | P, Q | X |
| E90H-24MCC-FW | 0192 | 15/30/75/95 | | X | FIRE | | X | P, Q | X |
| E90H-24MCCH-FR | 0194 | 115/177 | X | | FIRE | | X | P, Q | X |
| E90H-24MCCH-FW | 0193 | 115/177 | | X | FIRE | | X | P, Q | X |

Table 4. Specifications

| | |
|--|--|
| Physical | |
| Material | Red or white textured UV stabilized, colored impregnated engineered plastic. Exceeds 94V-0 UL flammability rating. |
| Weight | E70H Speaker: 1.7 lbs (0.77 kg); E70H Speaker Strobe 1.8 lbs (0.82kg); E90H Speaker: 1.5 lbs (0.68 kg); E90H Speaker Strobe 1.6 lbs (0.73 kg) |
| Lens (Material type) | GE Lexan 943A |
| Dimensions | E70H Speaker: 5.13" W x 5.13" H x 0.43"D; E70H Speaker Strobe: 5.13" W x 5.13" H x 2.56"D; E90H Speaker: 7.27" Diameter x 0.43" D; E90H Speaker Strobe: 7.327 Diameter x 2.68" D |
| Operating Temperature | Indoor: 33.8°F to 120.2°F (0°C to 49°C) and maximum humidity of 93% |
| Mounting & Wire Connections | |
| Mounting (indoor only) | 4" square backbox with extension ring prevents wire damage; SBB for surface mount of E70H |
| Wire Connections | #12 through #18 AWG |
| Power & General | |
| Operating voltage | 25/70 VRMS |
| Strobe Output Rating | UL 1971, ULC S526 |
| Strobe Flash Rate | Strobes are designed to flash at 1 flash per second |
| Synchronization Models | Strobes can be synchronized with Wheelock's DSM Sync Modules, Power Supplies or SAFEPATH products, using Wheelock patented sync protocol |
| Frequency Range | 300 Hz to 8000 Hz |

^a RMS current ratings are per UL maximum RMS method. UL max current rating is the maximum RMS current within the listed voltage range (16-33v for 24v units). For strobes the UL max current is usually at the minimum listed voltage (16v for 24v units). For audibles the max current is usually at the maximum listed voltage (33v for 24v units). For unfiltered FWR ratings, see installation instructions.

^b dBA ratings are based on testing under UL Standard 1480.

^c 1/8 watt tap is for private mode only.

Architects and Engineers Specifications

The speaker appliances shall be Wheelock Series E70H or E90H High Fidelity Speakers and Speaker Strobe appliances or approved equals. The speakers shall be UL Listed under UL 1480 for Fire Protective Service and speakers equipped with strobes shall be listed under UL 1971 for Emergency Devices for the Hearing-Impaired. In addition, the strobes shall be certified to meet the requirements of FCC Part 15, Class A.

All speakers shall be designed for a field selectable input of either 25 or 70 VRMS, with selectable power taps from 1/8 watt to 2 watts. All models shall have listed sound output of up to 87 dB at 10 feet and a listed frequency response of 300 to 8000 Hz. The speaker shall also incorporate a sealed back construction. All inputs shall employ terminals that accept #12 to #18 AWG wire sizes. The strobe portion of the appliance shall produce a flash rate of one (1) flash per second over the Regulated Voltage Range. The strobe shall be of low current design. Where Multi-Candela Speaker Strobes are specified, the strobe intensity shall have field selectable settings and shall be rated per UL 1971 at 15/30/75/110cd or 135/185cd for wall mount and 15/30/75/95cd or 115/177cd for ceiling mount. The selector switch for selecting the candela shall be tamper resistant. Models with 1575 candela shall also be offered for wall-mount applications.

When synchronization is required, the strobe portion of the appliance shall be compatible with Wheelock DSM sync modules, Wheelock

Power Supplies or other manufacturers panels incorporating the Wheelock Patented Sync Protocol. The strobes shall not drift out of synchronization at any time during operation. If the sync module or Power Supply fails to operate, (i.e., contacts remain closed), the strobe shall revert to a non-synchronized flash rate.

The speaker and speaker strobe appliances shall be designed for indoor surface or flush mounting. The speaker and speaker strobe shall incorporate a speaker mounting plate with a grille cover which is secured with two screws for a level, aesthetic finish and shall mount to standard electrical hardware requiring no additional trimplate or adapter.

The finish of the Series EH speakers and strobe speakers shall be red or white.

All speaker and speaker strobe appliances shall be backward compatible.

The speaker shall be listed to the low frequency requirements of UL 464 (520 Hz) to meet NFPA's 520 Hz tone requirements for sleeping areas.

UL 1971, UL 1480, ULC-S526, ULC-S541, CSFM, FCC.

Note: Due to continuous development of our products, specifications and offerings are subject to change without notice in accordance with Cooper Wheelock Inc., dba Eaton standard terms and conditions.



WE ENCOURAGE AND SUPPORT NICET CERTIFICATION
3 YEAR WARRANTY

Eaton
1000 Eaton Boulevard
Cleveland, OH 44122
United States
Eaton.com

Eaton
Life safety & mass notification solutions
273 Branchport Ave.
Long Branch, NJ 07740
www.eaton.com/massnotification

© 2016 Eaton
All Rights Reserved
Printed in USA
Publication No. TD450018EN
January 2016

Eaton is a registered trademark.

All other trademarks are property of their respective owners.

CALIFORNIA DEPARTMENT OF FORESTRY & FIRE PROTECTION
OFFICE OF THE STATE FIRE MARSHAL
FIRE ENGINEERING - BUILDING MATERIALS LISTING PROGRAM



LISTING SERVICE

LISTING No. 7125-0785:0173 Page 1 of 1

CATEGORY: 7125 -- FIRE ALARM DEVICES FOR THE HEARING IMPAIRED

LISTEE: Cooper Wheelock Inc. 7246 16th St. E., Ste. 105, Sarasota, FL 34243
Contact: Tom Conover (941) 487-2336
Email: thomas.conover@cooperindustries.com

DESIGN: Models E60H-24MCC, E60H-24MCCH, E70H-24MCW, E70H-24MCWH, E70H-241575W, E90H-24MCC, and E90H-24MCCH high fidelity multi-candela speaker-stobes followed by suffixes to designate lettering and plate color. Refer to listee's data sheet for additional detailed product description and operational considerations.

RATING: 25 or 70 Vrms

INSTALLATION: In accordance with listee's printed installation instructions, NFPA 72, applicable codes & ordinances and in a manner acceptable to the authority having jurisdiction.

MARKING: Listee's name, model number, electrical rating and UL label.

APPROVAL: Listed as speakers-strobe for use with separately listed electrically compatible fire alarm control units. For indoor use only.

09-20-12 gt



This listing is based upon technical data submitted by the applicant. CSFM Fire Engineering staff has reviewed the test results and/or other data but does not make an independent verification of any claims. This listing is not an endorsement or recommendation of the item listed. This listing should not be used to verify correct operational requirements or installation criteria. Refer to listee's data sheet, installation instructions and/or other

Date Issued: **July 01, 2015**

Listing Expires **June 30, 2016**

Authorized By: **JAMES PARSESIAN, Program Coordinator**
Fire Engineering Division

Weatherproof appliances

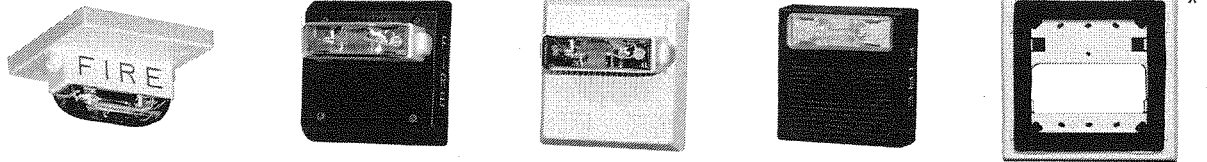

Description

Designed for life safety, performance and reliability, Eaton's Wheelock cost-effective weatherproof notification appliances include:

| Weatherproof Appliances | Series |
|-------------------------|------------------|
| Strobes | RSSWP |
| Horn strobes | ASWP |
| Horn | AH-24WP, AH-12WP |
| Multitone horn strobes | MTWP |
| Multitone horns | MT |
| Speaker strobes | ET70WP |
| Speakers | ET-1010 |

All strobe models are UL dual listed—meeting both UL1638 and UL1971 requirements. As dual listed appliances, these weatherproof strobes, horn strobes and speaker strobes are listed for outdoor applications under UL 1638 as well as under UL 1971, the Standard for Safety Signaling Devices for Hearing Impaired. With an extended temperature range of -31°F to 150°F (-35°C to 66°C), Wheelock weatherproof appliances meet or exceed UL outdoor test requirements for rain, humidity and corrosion resistance while providing multiple strobe intensity options, including the highest strobe ratings available for area coverage per NFPA 72 strobe spacing tables (up to 185 candela for wall mounting and 177 candela for ceiling mounting).

To enable weatherproof mounting, Eaton provides the industry's widest choice of mounting options for surface or unique semi-flush installation. Models are available for surface mounting to Wheelock weatherproof backboxes on walls or ceilings. The optional WP-KIT allows the weatherproof backboxes (IOB, WPBB or WPSBB) to be mounted to a recessed electrical box for concealed conduit installation. For semi-flush installation, the WPA* and WFPA* kits allow a customer to mount the weatherproof appliances to a recessed electrical box without the need for an external weatherproof backbox. See Table 10 on page three of this document for a summarization of these mounting options and the required accessories.

All models may be synchronized using the Wheelock DSM Sync Modules, Wheelock Power Supplies or other manufacturers panels incorporating the Wheelock Patented Sync Protocol. The horn output of horn strobes can be independently controlled on 2-wire circuits using the Wheelock patented sync protocol. MTWP horn strobe models are 4-wire appliances; the strobes can be synchronized while the audible can be connected to a coded fire alarm system or can be set to produce any of eight selectable tones.



Powering Business Worldwide

Features & benefits

- Weatherproof with extended temperature range of -40°F to 150°F (-40°C to 66°C)*
- Dual Listed strobe models (UL 1638 and UL 1971)
- Industry's highest strobe candela options
- Synchronize using the Wheelock Sync Modules or panels with built-in Wheelock Patented Sync Protocol
- Models with field selectable tone, dBA and candela settings
- Wall or ceiling mounting options
- Surface or semi-flush mounting
- IN/OUT wiring termination accepting two #12-18 AWG wires at each terminal

Note: All CAUTIONS and WARNINGS are identified by the symbol . All warnings are printed in bold capital letters.

WARNING

PLEASE READ THESE SPECIFICATIONS AND ASSOCIATED INSTALLATION INSTRUCTIONS CAREFULLY BEFORE USING, SPECIFYING OR APPLYING THIS PRODUCT. FAILURE TO COMPLY WITH ANY OF THESE INSTRUCTIONS, CAUTIONS OR WARNINGS COULD RESULT IN IMPROPER APPLICATION, INSTALLATION AND/OR OPERATION OF THESE PRODUCTS IN AN EMERGENCY SITUATION, WHICH COULD RESULT IN PROPERTY DAMAGE, AND SERIOUS INJURY OR DEATH TO YOU AND/OR OTHERS.

Approvals & compliances

- Approvals include: UL Standards 1971, 1638, 464 and 1480; California State Fire Marshal (CSFM); New York City (MEA); Factory Mutual (FM); Chicago (BFP) and ULC (see agency approvals by model number on pages 4 and 5 of this document)
- The series RSSWP, ASWP, AH-24WP, MTWP-2475W, and MT-12/24 have UL/ULC approval down to -40°F. The ET-1010 and ET70WP have UL approval down to -40°F. The AH-12WP has UL approval down to -31°F.
- Compliance with the following requirements: NFPA; UFC; ANSI 117.1; OSHA Part 29, 1910.165; AD

General notes

- Strobes are designed to flash at 1 flash per second minimum over their UL Listed Regulated Voltage Range.
- All candela ratings represent minimum effective Strobe intensity based on UL Standards 1971 and 1638 as indicated in candela ratings table.
- Models are available in red or white. Contact Customer Service for order code and delivery.

Drawings

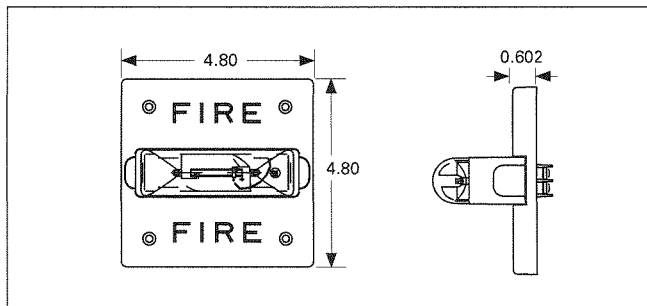

Figure 1. RSSWP front and side views

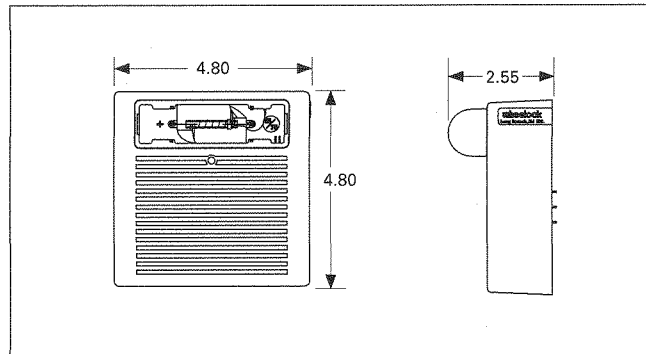

Figure 2. ASWP front and side views

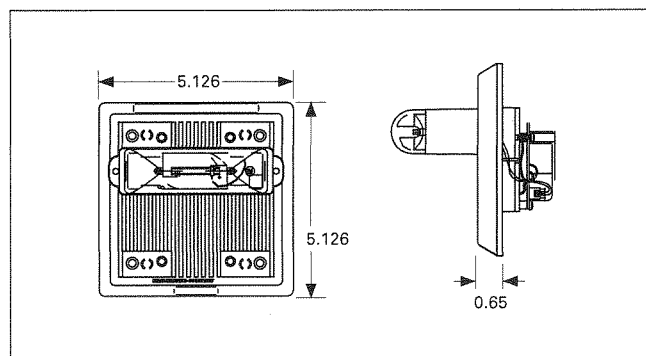

Figure 3. MTWP front and side views

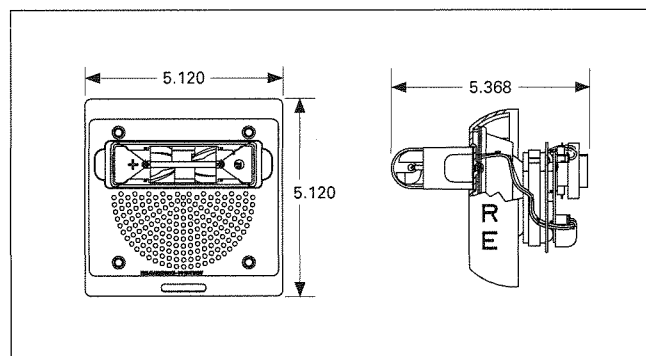

Figure 4. ET70WP front and side views

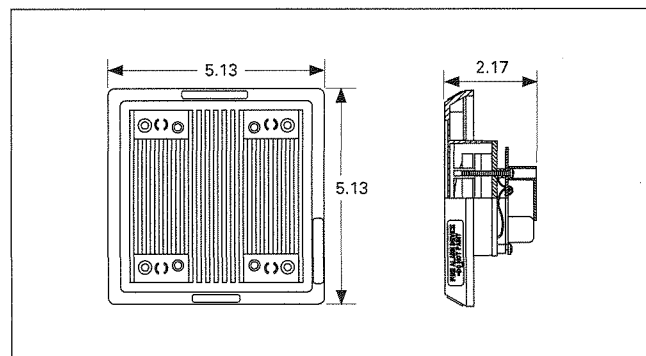

Figure 5. MT front and side views

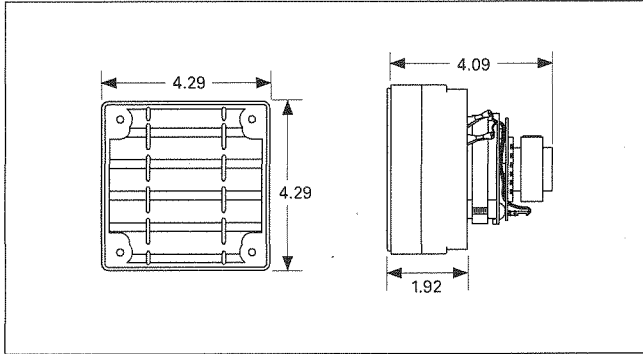

Figure 6. ET-1010 front and side views

Table 1. Maximum UL current for AH models

| | UL Max Current for AH | |
|---------------|-----------------------|--------|
| | 24 VDC | 12 VDC |
| High (99) dBA | 0.080 | 0.192 |
| Med (95) dBA | 0.043 | 0.108 |
| Low (90) dBA | 0.021 | 0.058 |

Table 2. dBA ratings for ET-1010 and ET70WP models

| Model | UL Reverberant dBA @ 10 ft. | | | | | | |
|---------|-----------------------------|-----|-----|----|----|----|----|
| | Watts | | | | | | |
| | 1/8 | 1/4 | 1/2 | 1 | 2 | 4 | 8 |
| ET-1010 | 77 | 80 | 83 | 86 | 87 | 92 | 94 |
| ET70WP | 78 | 81 | 84 | 87 | 90 | 93 | 95 |

Table 3. Maximum UL current (audible)

| dBA | MTWP/MT 24 VDC | | MT 12 VDC | |
|-------------|-------------------|-------|--------------|-------|
| | HI | STD | HI | STD |
| Horn | 0.108 | 0.044 | 0.177 | 0.034 |
| Bell | 0.053 | 0.024 | 0.095 | 0.020 |
| March Time | 0.104 | 0.038 | 0.142 | 0.034 |
| Code 3 Horn | 0.091 | 0.035 | 0.142 | 0.034 |
| Code 3 Tone | 0.075 | 0.035 | 0.105 | 0.021 |
| Slow Whoop | 0.098 | 0.037 | 0.142 | 0.035 |
| Siren | 0.104 | 0.036 | 0.152 | 0.030 |
| Hi/Lo | 0.057 | 0.025 | 0.114 | 0.026 |



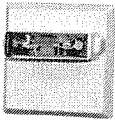

Table 4. Candela ratings

| Series | UL 1971 | UL 1638 @ 77°F | UL 1638 @ -40°F | RSS, ET70WP and MTWP UL Max Current (strobe only) | ASWP | | |
|--------|---------|----------------|-----------------|--|-------|-------|-------|
| | | | | | High | Med | Low |
| 2475W | 30 ① | 180 | 115 | 0.138 | 0.168 | 0.155 | 0.150 |
| 2475C | 15 | 180 | 115 | 0.138 | 0.168 | 0.155 | 0.150 |
| MCWH | 135 | 135 | 56 | 0.300 | 0.355 | 0.340 | 0.335 |
| | 185 | 185 | 77 | 0.420 | 0.480 | 0.465 | 0.460 |
| MCCH | 115 | 115 | 47 | 0.300 | 0.355 | 0.340 | 0.335 |
| | 177 | 177 | 73 | 0.420 | 0.480 | 0.465 | 0.460 |
| 24185 | 185 | 185 | 77 | 0.420 | | | |
| 24177 | 177 | 177 | 73 | 0.420 | | | |

① Wall mount rating only



Wall mount models

Table 5. Specification and ordering information

| Model Number | Finish | Order Code | Agency Approvals | | | | | |
|--|--------|------------|------------------|-----|------|----|-----|--|
| | | | UL | MEA | CSFM | FM | BFP | |
| Strobe | | | | | | | | |
| RSSWP-2475W-FR | Red | 9013 | X | X | X | X | - | |
| RSSWP-2475W-FW | White | 3034 | X | X | X | X | - | |
| RSSWP-24MCWH-FR | Red | 5161 | X | - | X | - | - | |
| RSSWP-24MCWH-FW | White | 5165 | X | - | X | - | - | |
|  | | | | | | | | |
| Audible strobe | | | | | | | | |
| ASWP-2475W-FR | Red | 9012 | X | X | X | X | X | |
| ASWP-24MCWH-FR | Red | 5137 | X | - | X | - | - | |
| ASWP-24MCWH-FW | White | 5140 | X | - | X | - | - | |
|  | | | | | | | | |
| Multitone strobe | | | | | | | | |
| MTWP-2475W-FR | Red | 8420 | X | X | X | X | - | |
| MTWP-2475W-FW | White | 3112 | X | X | X | X | - | |
| MTWP-24MCWH-FR | Red | 5132 | X | - | X | - | - | |
| MTWP-24MCWH-FW | White | 5134 | X | - | X | - | - | |
|  | | | | | | | | |
| Speaker strobe | | | | | | | | |
| ET70WP-2475W-FR | Red | 9077 | X | - | X | X | - | |
| ET70WP-2475W-FW | White | 3179 | X | - | X | X | - | |
| ET70WP-24185W-FR | Red | 4885 | X | - | X | X | - | |
| ET70WP-24185W-FW | White | 4891 | X | - | X | X | - | |
|  | | | | | | | | |

Ceiling mount models

Table 6. Specification and ordering information

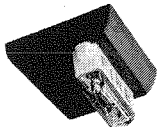
| Model Number | Finish | Order Code | Agency Approvals | | | | | |
|---|--------|------------|------------------|-----|------|----|-----|--|
| | | | UL | MEA | CSFM | FM | BFP | |
| Strobe | | | | | | | | |
| RSSWP-2475C-FR | Red | 4338 | X | X | X | X | - | |
| RSSWP-2575C-FW | White | 4446 | X | X | X | X | - | |
| RSSWP-24MCCH-FR | Red | 5167 | X | - | X | - | - | |
| RSSWP-24MCCH-FW | White | 5187 | X | - | X | - | - | |
|  | | | | | | | | |
| Audible strobe | | | | | | | | |
| ASWP-2475C-FR | Red | 4251 | X | X | X | X | X | |
| ASWP-2475C-FW | White | 4502 | X | X | X | X | X | |
| ASWP-24MCCH-FR | Red | 5149 | X | - | X | - | - | |
| ASWP-24MCCH-FW | White | 5157 | X | - | X | - | - | |
|  | | | | | | | | |
| Multitone strobe | | | | | | | | |
| MTWP-2474C-FR | Red | 4457 | X | X | X | X | - | |
| MTWP-2475C-FW | White | 4458 | X | X | X | X | - | |
| MTWP-24MCCH-FR | Red | 5102 | X | - | X | - | - | |
| MTWP-24MCCH-FW | White | 5122 | X | - | X | - | - | |
|  | | | | | | | | |
| Speaker strobe | | | | | | | | |
| ET70WP-2475C-FR | Red | 4452 | X | - | X | X | - | |
| ET70WP-2475C-FW | White | 4454 | X | - | X | X | - | |
| ET70WP-24177C-FR | Red | 4845 | X | - | X | X | - | |
| ET70WP-24177C-FW | White | 4859 | X | - | X | X | - | |
|  | | | | | | | | |

Wall or ceiling mount models

Table 7. Specification and ordering information

| Model Number | Finish | Order Code | Agency Approvals | | | | |
|----------------|--------|------------|------------------|-----|------|----|-----|
| | | | UL | MEA | CSFM | FM | BFP |
| Audible | | | | | | | |
| AH-24WP-R | Red | 7416 | X | X | X | X | X |
| AH-12WP-R | Red | 7415 | X | X | X | X | X |
| Horn | | | | | | | |
| MT-12/24-R | Red | 5023 | X | X | X | X | X |
| Speaker | | | | | | | |
| ET-1010-R | Red | 3135 | X | X | X | X | X |
| ET-1010-W | White | 3137 | X | X | X | X | X |

Mounting accessories

Table 8. Ordering information

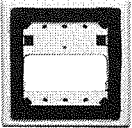
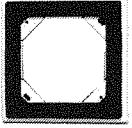
| Model Number | Finish | Order Code | Model Number | Finish | Order Code |
|---|--------|------------|---|--------|------------|
| Backboxes | | | Gasket kit | | |
| IOB-R ① | Red | 5046 | WP-KIT | N/A | 4486 |
| IOB-W ① | White | 5047 | Flush plates | | |
|  | | | WFPA-R | Red | 4698 |
| WPSBB-R ① | | | WFPA-W | White | 4701 |
| WPSBB-W ① | | |  | | |
| WPBB-R ① | | | WFP-R | Red | 4696 |
| WPBB-W ① | | | WFP-W | White | 4697 |
| WBB-R | | |  | | |
| WBB-W | | | | | |

① IOB, WPSBB and WPBB models include weep holes and plug in the event that moisture may have entered the appliance.

Table 9. Mounting options

| Mounting Options | Surface Mount | | Flush Mount |
|------------------------|-----------------|-------------------|-------------|
| | Exposed Conduit | Concealed Conduit | |
| RSSWP Strobes | WPSBB | WPSBB + WP-KIT | WFP |
| ET70WP Speaker Strobes | IOB | IOB + WP-KIT | WFP |
| ASWP Horn Strobes | WPBB | WPBB + WP-KIT | WFPA |
| AHWP Horns | WBB | — | WFP |
| ET-1010 Speakers | WBB | — | WFP |
| MTWP Multitone Strobes | IOB | IOB + WP-KIT | WFP |
| Multitone | IOB | IOB + WP-KIT | WFP |

Note: Refer to Data Sheet TD450028EN for mounting options

Architects and engineers specifications

General

Weatherproof notification appliances shall be UL listed for outdoor use. Weatherproof Strobe appliances shall be listed under UL Standard 1638 (Standard for Visual Signaling Appliances) for Indoor/Outdoor use and UL Standard 1971 (Standard for Safety Signaling Devices for Hearing Impaired). The appliances shall be available for optional wall mounting or ceiling mounting to weatherproof backboxes using either exposed conduit, concealed conduit, or semi-flush mounting to a recessed electrical box in walls or ceilings using Wheelock mounting accessories.

Weatherproof Strobes

Weatherproof Strobe appliances shall produce a minimum flash rate of 60 flashes per minute over the UL Regulated Voltage Range of 16 to 33 VDC and shall incorporate a Xenon flashtube. The weatherproof strobes shall be available with UL 1971 candela ratings up to 185 cd for wall mounting and 177 cd for ceiling mounting. UL 1638 candela ratings up to 180 cd at 77°F shall be available. The strobes shall operate over an extended temperature range of -40°F to 150°F (-40°C to 66°C) and be listed for maximum humidity of 95% RH. Strobe inputs shall be polarized for compatibility with standard reverse polarity supervision of circuit wiring by a Fire Alarm Control Panel (FACP).

Weatherproof Audibles and Audible/Strobe Combinations Weatherproof horns and multitone audibles shall be listed for Indoor/Outdoor use under UL Standard 464. The horns shall be able to produce a continuous output or a temporal code-3 output that can be synchronized. The horns shall have at least 3 sound level settings. Horn/Strobe combinations shall be able to be synchronized on a single NAC.

Multitone audibles shall be able to produce 8 distinct tones selectable by dip switch and shall have at least 2 sound level settings. Multitone Audible/Strobe combinations shall have independent inputs for the audible and strobe. The strobes shall be able to be synchronized. The audibles shall be able to be coded when operated on a separate NAC.

Weatherproof Speakers and Speaker/Strobes

Weatherproof speakers and speaker/strobes shall be listed for Indoor/Outdoor use under UL Standard 1480. All speakers shall provide field selectable taps for 1/8W to 8W operation for either 25 VRMS or 70 VRMS audio systems and shall incorporate a sealed back construction for extra protection and improved audibility. Speakers without strobes shall be Wheelock Series ET-1010. They shall be listed to produce up to 94 dBA and shall incorporate a vandal resistant grille design. Speaker with strobes shall be Wheelock Series ET70WP. They shall be available for surface or semi-flush mounting to walls or ceilings and shall be listed to produce up to 93 dBA.

Synchronization Modules

When synchronization of strobes or temporal code-3 audibles is required, the appliances shall be compatible with the Wheelock Series DSM Sync Modules, Wheelock Power Supplies or other manufacturers panels with built-in Wheelock Patented Sync Protocol. The strobes and audibles shall not drift out of synchronization at any time during operation.

Series ASWP audibles and strobes shall be able to be synchronized on a 2-wire circuit with the ability to silence the audible if required. The strobes on Series MT multitone audible/strobe appliances shall be able to be synchronized and shall be able to be operated on a separate circuit from the audibles while the audible circuit is connected to a coded or continuous NAC.

Weatherproof Mounting Accessories

Weatherproof mounting options shall include surface mounting or semi-flush mounting to walls or ceilings. Surface mounted appliances shall mount to Wheelock IOB, WBB, WPBB or WPSBB weatherproof backboxes using either exposed conduit or concealed conduit. For concealed conduit the weatherproof backbox shall be mounted to a recessed electrical box with Wheelock's WP-KIT to provide a weatherproof seal for the electrical box. Semi-flush mounted appliances shall mount to a recessed electrical box using Wheelock WFP or WFPA flush plates to provide a weatherproof seal between the electrical box and the appliance.



WE ENCOURAGE AND SUPPORT NICET CERTIFICATION
3-YEAR WARRANTY

Eaton
1000 Eaton Boulevard
Cleveland, OH 44122
United States
Eaton.com

Eaton
Life safety & mass notification solutions
273 Branchport Ave.
Long Branch, NJ 07740
Eaton.com/massnotification

© 2017 Eaton
All Rights Reserved
Printed in USA
Publication No. TD450112EN
September 2017

Eaton is a registered trademark.

All other trademarks are property
of their respective owners.

CALIFORNIA DEPARTMENT OF FORESTRY & FIRE PROTECTION
OFFICE OF THE STATE FIRE MARSHAL
FIRE ENGINEERING - BUILDING MATERIALS LISTING PROGRAM



LISTING SERVICE

LISTING No. 7320-0785:0105

Page 1 of 1

CATEGORY: 7320 -- SPEAKERS

LISTEE: Cooper Wheelock Inc. 7246 16th St. E., Ste. 105, Sarasota, FL 34243
Contact: Tom Conover (941) 487-2336
Email: thomas.conover@cooperindustries.com

DESIGN: Models ET-1010, ET-1011, ET-1070, ET-1071, ET-1080, ET-1081, ET-1090 and ET-1091 series speaker or speaker/strobe. Refer to listee's data sheet for product description and operational considerations.

RATING:

INSTALLATION: In accordance with listee's printed installation instructions, NFPA 72, applicable codes and ordinances and in a manner acceptable to the authority having jurisdiction.

MARKING: Listee's name, model number, electrical rating and UL label.

APPROVAL: Listed as a speaker for use with separately listed compatible fire alarm control units.

If this appliance is required to produce a distinctive three-pulse Temporal Pattern Fire Alarm Evacuation Signal (for total evacuation) in accordance with NFPA 72, 2002 Edition, the appliance must be used with a fire alarm control unit that can generate the temporal pattern signal. Refer to manufacturer's Installation Manual for details.

NOTE:

*Rev. 06-13-2006



This listing is based upon technical data submitted by the applicant. CSFM Fire Engineering staff has reviewed the test results and/or other data but does not make an independent verification of any claims. This listing is not an endorsement or recommendation of the item listed. This listing should not be used to verify correct operational requirements or installation criteria. Refer to listee's data sheet, installation instructions and/or other

Date Issued: **July 01, 2018**

Listing Expires **June 30, 2019**

Authorized By: **DAVID CASTILLO**, Program Coordinator
Fire Engineering Division

**NO
EXCUSES!**

SIGNALING

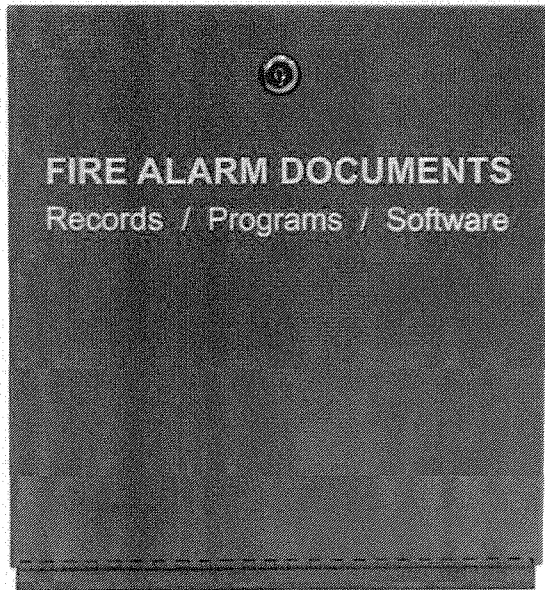
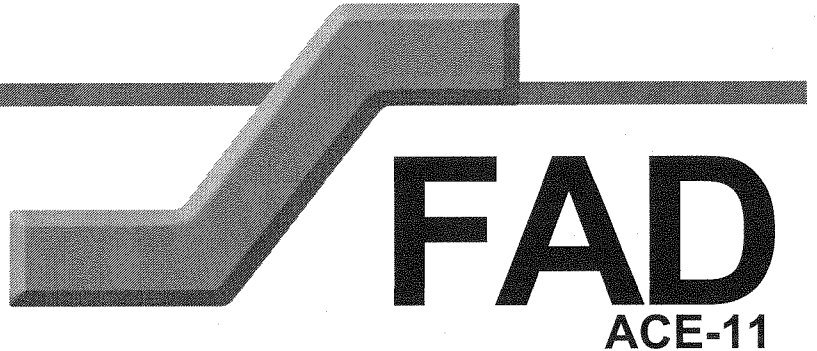

FIRE ALARM DOCUMENTS

The FAD is the perfect fit to meet the demanding code requirements today. SAE's number one goal is to manufacture code compliant solutions and this product allows you to do just that. NFPA 72 2007 section 6.2.2.1 states, "A record of installed software and firmware version numbers shall be maintained at the location of the fire alarm control unit."

This durable 16 gauge steel enclosure with a solid piano hinge and key lock will keep all of your code required documents in one safe place. With a 4GB USB flash drive it stores your fire alarm software safe and secure eliminating the occurrences of the software not being on site when technicians arrive to service the system. Along with your fire alarm software you can store your test & inspection documents, service records, manuals & AS built drawings for the system. Using a standard USB B connector it allows you to plug in with any standard SB printer cable to upload or download information.

The FDB is designed to hold critical manuals and documents with a durable steel retainer. It has designated hooks to organize key rings and hold important business cards for easy access and reference. Inside the cover it has a organized note table that allows for documentation for passwords and other critical system information.

Standard Features:

- Installed with a 4 gig digital flash drive with USB B connector
- 2 Key ring hooks to hold system keys
- Business card holder for key contacts
- Overall Dimensions are 12" x 13" tall and 2 ¼ deep
- 16 gauge steel box and cover for security
- Durable powercoat baked on finish other colors available
- Standard ¾" cat 30 key lock other lock assemblies available
- Solid stainless steel piano hinge
- Permanently screened white ink 1" high "Fire Alarm Documents"
- Legend sheet for passwords and system information



ISO 9001
REGISTERED
COMPANY

ACEBOX

Space Age Electronics, Inc.
www.1sae.com
800.486.1723 Toll Free
508.485.0966 Local
508.485.4740 Fax

Specifications:

The fire alarm documents box (FAD) shall be UL Listed, constructed of 18 gauge cold rolled steel. It shall have a red powder coat epoxy finish. The cover shall be permanently screened with 1" high lettering "FIRE ALARM DOCUMENTS " with white indelible ink. The access door shall be locked with a 3/4" barrel lock and the hinge shall be a solid width 12" stainless steel piano hinge. The enclosure will supply 4 mounting holes. Inside the enclosure will accommodate standard 8 1/2 x 11 manuals and loose document records that will be protected within the enclosure. A legend sheet will be permanently attached to the door for system required documentation, key contacts and system information. The FAD will have securely mounted inside a minimum of 4 Gigabyte digital flash memory drive with a standard USB B connector for uploading and downloading information. The drive shall not be accessible without tools to any person whom gains access to the records. The enclosure shall also provide 2 key ring holders with a location to mount standard business type cards for key contact personnel.

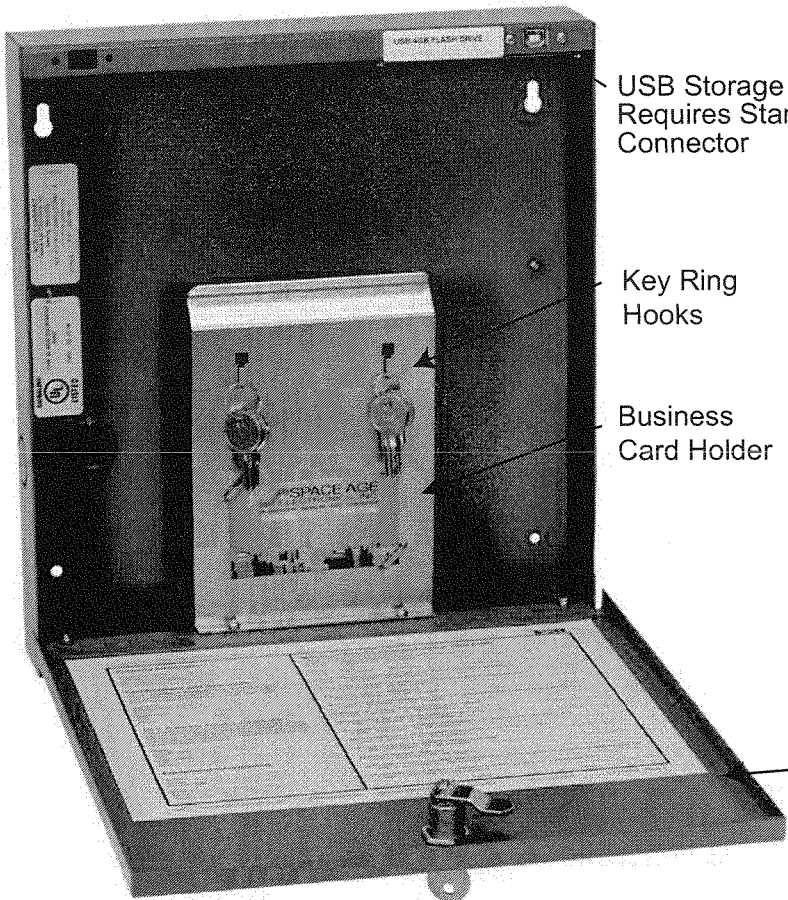

USB Storage Interface
Requires Standard USB-B
Connector

Key Ring
Hooks

Business
Card Holder

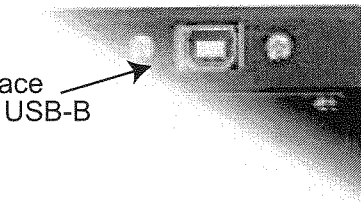

For replacement forms order PIN: EA0316 (Qty: 10)

| Property Information | Minimum Required Documentation (SIG-FUN) (Reference NFPA-72 2013 Section 7.2.1) |
|--|---|
| Name of property: _____ | 1 Written narrative providing information and system description ☐ N/A ☐ Enclosed ☐ At Location _____ |
| Address: _____ | 2 Riser diagram ☐ N/A ☐ Enclosed ☐ At Location _____ |
| Description of property: _____ | 3 Floor plan layout showing location of all devices and control equipment ☐ N/A ☐ Enclosed ☐ At Location _____ |
| Occupancy type: _____ | 4 Sequence of operation in either an input/output matrix or narrative form ☐ N/A ☐ Enclosed ☐ At Location _____ |
| Certifications and Approvals | |
| 16.1 System Installation Contractor: This system, as specified herein, has been installed and tested according to all NFPA standards cited herein. | |
| Signed: _____ | |
| Printed name: _____ | |
| Date: _____ | |
| Organization: _____ | |
| Title: _____ | |
| Phone: _____ | |
| 16.5 Authority Having Jurisdiction: I have witnessed a satisfactory acceptance test of this system and find it to be installed and operating properly in accordance with its approved plans and specifications, with its approved sequence of operations, and with all NFPA standards cited herein. | |
| Signed: _____ | |
| Printed name: _____ | |
| Date: _____ | |
| Organization: _____ | |
| Title: _____ | |
| Phone: _____ | |
| Equipment Information | |
| ID No 1: _____ | 12 Record (as-built) drawings ☐ N/A ☐ Enclosed ☐ At Location _____ |
| Serial: _____ | 13 Periodic inspection, testing, and maintenance documentation in accordance with Section 7.6 ☐ N/A ☐ Enclosed ☐ At Location _____ |
| Access code: _____ | 14 Records, record retention, and record maintenance in accordance with 7.7 ☐ N/A ☐ Enclosed ☐ At Location _____ |
| ID No 2: _____ | |
| Serial: _____ | |
| Access code: _____ | |
| | Signed: _____ Date: _____ |

Legend sheet for storing system information including contacts, sign-off, maintenance & test information, and alternate locations of additional records.

Ordering Information:

Part # Description

SSU00685 Fire Alarm Storage Cabinet RED

SSU00686 Custom screening with your Logo

Check out our Infinity line eFAD single gang 2 Gig digital storage solutions (IAMEFAD)

ACERBOX

Space Age Electronics, Inc.
www.1sae.com
800.486.1723 Toll Free
508.485.0966 Local
508.485.4740 Fax

No Excuses, Just Solutions!

This document is subject to change without notice, see doc # ED0479 for legal disclaimer

CALIFORNIA DEPARTMENT OF FORESTRY & FIRE PROTECTION
OFFICE OF THE STATE FIRE MARSHAL
FIRE ENGINEERING - BUILDING MATERIALS LISTING PROGRAM



LISTING SERVICE

LISTING No. 7300-0553:0110

Page 1 of 1

CATEGORY: 7300 -- FIRE ALARM CONTROL UNIT ACCESSORIES/MISC. DEVICES

LISTEE: SPACE AGE ELECTRONICS 58 Chockett Road, Sterling, MA 01564
Contact: Robert Scholl (508) 485-0966 Fax (508) 485-4740
Email: bobs@1sae.com

DESIGN: Models TC2-32, TC1-18, TCX/A 64, TCX/D 128, ACE/A, AC2, ACE/D, IF-2, IF1, IFX/A and IFX/D enclosures. Models ACE-11, ACE-12 and ACE-13, *ACE2424, *ACE 3036, *ACE 2436, *ACE 3048 document cabinets. Refer to listee's data sheet for detailed product description and operational considerations.

INSTALLATION: In accordance with listee's printed installation instructions, applicable codes and ordinances and in a manner acceptable to the authority having jurisdiction.

MARKING: Listee's name, model number and UL label.

APPROVAL: Listed as fire alarm equipment enclosures and document cabinets for use with listee's fire alarm equipment. Refer to listee's Installation Instruction Manual for details.

02-09-16 dc



This listing is based upon technical data submitted by the applicant. CSFM Fire Engineering staff has reviewed the test results and/or other data but does not make an independent verification of any claims. This listing is not an endorsement or recommendation of the item listed. This listing should not be used to verify correct operational requirements or installation criteria. Refer to listee's data sheet, installation instructions and/or other

Date Issued: **July 01, 2018**

Listing Expires **June 30, 2019**

Authorized By: **DAVID CASTILLO**, Program Coordinator
Fire Engineering Division

SECTION 31 1000

SITE CLEARING

PART 1 - GENERAL

1.1 RELATED DOCUMENTS

- A. Drawings and general provisions of the Contract, including General and Supplementary Conditions and Division 01 Specification Sections, apply to this Section.

1.2 SUMMARY

- A. Section Includes:
 - 1. Protecting existing vegetation to remain.
 - 2. Removing existing vegetation.
 - 3. Clearing and grubbing.
 - 4. Stripping and stockpiling topsoil.
 - 5. Removing above- and below-grade site improvements.
 - 6. Disconnecting, capping or sealing, and abandoning site utilities in place.
 - 7. Temporary erosion- and sedimentation-control measures.
- B. Related Sections:
 - 1. Section 01 7300 "Execution" for field engineering and surveying.

1.3 DEFINITIONS

- A. Subsoil: All soil beneath the topsoil layer of the soil profile, and typified by the lack of organic matter and soil organisms.
- B. Surface Soil: Soil that is present at the top layer of the existing soil profile at the Project site. In undisturbed areas, the surface soil is typically topsoil; but in disturbed areas such as urban environments, the surface soil can be subsoil.
- C. Topsoil: Top layer of the soil profile consisting of existing native surface topsoil or existing in-place surface soil and is the zone where plant roots grow.
- D. Topsoil: Top layer of the soil profile consisting of existing native surface topsoil or existing in-place surface soil and is the zone where plant roots grow. Its appearance is generally friable, pervious, and black or a darker shade of brown, gray, or red than underlying subsoil; reasonably free of subsoil, clay lumps, gravel, and other objects more than 2 inches in diameter; and free of subsoil and weeds, roots, toxic materials, or other non-soil materials.
- E. Plant-Protection Zone: Area surrounding individual trees, groups of trees, shrubs, or other vegetation to be protected during construction, and indicated on Drawings.

- F. Vegetation: Trees, shrubs, groundcovers, grass, and other plants.

1.4 MATERIAL OWNERSHIP

- A. Except for stripped topsoil and other materials indicated to be stockpiled or otherwise remain Owner's property, cleared materials shall become Contractor's property and shall be removed from Project site.

1.5 INFORMATIONAL SUBMITTALS

- A. Existing Conditions: Documentation of existing trees and plantings, adjoining construction, and site improvements that establishes preconstruction conditions that might be misconstrued as damage caused by site clearing.
 - 1. Use sufficiently detailed photographs or videotape.
 - 2. Include plans and notations to indicate specific wounds and damage conditions of each tree or other plants designated to remain.
- B. Record Drawings: Identifying and accurately showing locations of capped utilities and other subsurface structural, electrical, and mechanical conditions.

1.6 QUALITY ASSURANCE

- A. Preinstallation Conference: Conduct conference at Liberty High School at 20 Oak Street, Brentwood, CA.

1.7 PROJECT CONDITIONS

- A. Salvable Improvements: Carefully remove items indicated to be salvaged and store on Owner's premises.
- B. Utility Locator Service: Notify Call Before You Dig for area where Project is located before site clearing.
- C. Do not commence site clearing operations until temporary erosion- and sedimentation-control measures are in place.
- D. The following practices are prohibited within protection zones:
 - 1. Storage of construction materials, debris, or excavated material.
 - 2. Parking vehicles or equipment.
 - 3. Foot traffic.
 - 4. Erection of sheds or structures.
 - 5. Impoundment of water.
 - 6. Excavation or other digging unless otherwise indicated.
 - 7. Attachment of signs to or wrapping materials around trees or plants unless otherwise indicated.
- E. Do not direct vehicle or equipment exhaust towards protection zones.

- F. Prohibit heat sources, flames, ignition sources, and smoking within or near protection zones.
- G. Soil Stripping, Handling, and Stockpiling: Perform only when the topsoil is dry or slightly moist.

PART 2 - PRODUCTS

2.1 MATERIALS

- A. Satisfactory Soil Material: Requirements for satisfactory soil material are specified in Section 31 2000 "Earthwork."
 - 1. Obtain approved borrow soil material off-site when satisfactory soil material is not available on-site.

PART 3 - EXECUTION

3.1 PREPARATION

- A. Protect and maintain benchmarks and survey control points from disturbance during construction.
- B. Locate and clearly identify trees, shrubs, and other vegetation to remain or to be relocated. Wrap a 1-inch blue vinyl tie tape flag around each tree trunk at 54 inches above the ground.
- C. Protect existing site improvements to remain from damage during construction.
 - 1. Restore damaged improvements to their original condition, as acceptable to Owner.

3.2 TEMPORARY EROSION AND SEDIMENTATION CONTROL

- A. Provide temporary erosion- and sedimentation-control measures to prevent soil erosion and discharge of soil-bearing water runoff or airborne dust to adjacent properties and walkways, according to erosion- and sedimentation-control Drawings and requirements of authorities having jurisdiction.
- B. Verify that flows of water redirected from construction areas or generated by construction activity do not enter or cross protection zones.
- C. Inspect, maintain, and repair erosion- and sedimentation-control measures during construction until permanent vegetation has been established.
- D. Remove erosion and sedimentation controls and restore and stabilize areas disturbed during removal.

3.3 TREE AND PLANT PROTECTION

- A. General: Protect trees and plants remaining on-site according to requirements in Section 015639 "Temporary Tree and Plant Protection."

- B. Repair or replace trees, shrubs, and other vegetation indicated to remain or be relocated that are damaged by construction operations, in a manner approved by Architect.

3.4 EXISTING UTILITIES

- A. Owner will arrange for disconnecting and sealing indicated utilities that serve existing structures before site clearing, when requested by Contractor.
 - 1. Verify that utilities have been disconnected and capped before proceeding with site clearing.
- B. Locate, identify, disconnect, and seal or cap utilities indicated to be removed or abandoned in place.
 - 1. Arrange with utility companies to shut off indicated utilities.
 - 2. Owner will arrange to shut off indicated utilities when requested by Contractor.
- C. Locate, identify, and disconnect utilities indicated to be abandoned in place.
- D. Interrupting Existing Utilities: Do not interrupt utilities serving facilities occupied by Owner or others unless permitted under the following conditions and then only after arranging to provide temporary utility services according to requirements indicated:
 - 1. Notify Architect not less than two days in advance of proposed utility interruptions.
 - 2. Do not proceed with utility interruptions without Architect's written permission.
- E. Excavate for and remove underground utilities indicated to be removed.
- F. Removal of underground utilities is included in earthwork sections and with applicable fire suppression, plumbing, HVAC, electrical, communications, electronic safety and security and utilities sections and Section 024116 "Structure Demolition" and Section 024119 "Selective Demolition."

3.5 CLEARING AND GRUBBING

- A. Remove obstructions, trees, shrubs, and other vegetation to permit installation of new construction.
 - 1. Do not remove trees, shrubs, and other vegetation indicated to remain or to be relocated.
 - 2. Grind down stumps and remove roots, obstructions, and debris to a depth of 18 inches below exposed subgrade.
 - 3. Use only hand methods for grubbing within protection zones.
 - 4. Chip removed tree branches and dispose of off-site.
- B. Fill depressions caused by clearing and grubbing operations with satisfactory soil material unless further excavation or earthwork is indicated.

1. Place fill material in horizontal layers not exceeding a loose depth of 8 inches, and compact each layer to a density equal to adjacent original ground.

3.6 TOPSOIL STRIPPING

- A. Remove sod and grass before stripping topsoil.
- B. Strip topsoil to depth of 3 inches in a manner to prevent intermingling with underlying subsoil or other waste materials.
 1. Remove subsoil and non-soil materials from topsoil, including clay lumps, gravel, and other objects more than 2 inches in diameter; trash, debris, weeds, roots, and other waste materials.
- C. Stockpile topsoil away from edge of excavations without intermixing with subsoil. Grade and shape stockpiles to drain surface water. Cover to prevent windblown dust and erosion by water.
 1. Limit height of topsoil stockpiles to 60 inches.
 2. Do not stockpile topsoil within protection zones.
 3. Dispose of surplus topsoil. Surplus topsoil is that which exceeds quantity indicated to be stockpiled or reused.
 4. Stockpile surplus topsoil to allow for respreading deeper topsoil.

3.7 SITE IMPROVEMENTS

- A. Remove existing above- and below-grade improvements as indicated and necessary to facilitate new construction.
- B. Remove slabs, paving, curbs, gutters, and aggregate base as indicated.
 1. Unless existing full-depth joints coincide with line of demolition, neatly saw-cut along line of existing pavement to remain before removing adjacent existing pavement. Saw-cut faces vertically.
 2. Paint cut ends of steel reinforcement in concrete to remain with two coats of antirust coating, following coating manufacturer's written instructions. Keep paint off surfaces that will remain exposed.

3.8 DISPOSAL OF SURPLUS AND WASTE MATERIALS

- A. Remove surplus soil material, unsuitable topsoil, obstructions, demolished materials, and waste materials including trash and debris, and legally dispose of them off Owner's property.
- B. Separate recyclable materials produced during site clearing from other nonrecyclable materials. Store or stockpile without intermixing with other materials and transport them to recycling facilities. Do not interfere with other Project work.

END OF SECTION 31 1000

SECTION 31 2000

EARTHWORK

PART 1 - GENERAL

1.1 RELATED DOCUMENTS

- A. All earthwork shall be in conformance with the soils report.
- B. Drawings and general provisions of the contract, including General and Supplementary Conditions and Division I Specification Section, apply to this section.
- C. Published specifications, standards, tests, or recommended methods of trade, industry, or governmental organizations apply to Work of this Section where cited by abbreviations noted below (latest editions apply unless otherwise noted).
 - 1. California Code of Regulations, Title 24, 2013 edition, also known as California Building Code (CBC).
 - 2. American Society for Testing and Materials (ASTM).
 - 3. American Association of State Highway and Transportation Officials (AASHTO), "Standard Specifications for Highway Materials and Methods of Sampling and Testing."
 - 4. State of California, Business and Transportation Agency, Department of Public Works, Division of Highways:
 - (a) "Standard Specifications."
 - (b) "Materials Manual," (CMM).

1.2 SUMMARY

- A. Section Includes:
 - 1. Excavation including removal of known on- or below-grade construction or obstructions, and filling and backfilling.
 - 2. Provision of rock courses, sand beds, and vapor retarders under slabs on grade.
- B. Related Sections include:
 - 1. Section 31 2333 "Trenching and Backfill" for trenching and backfilling underground utilities and detectable warning tapes.

1.3 DEFINITIONS:

- A. Compaction: Ratio expressed as percentage of dry density of material compacted in field to maximum dry density of same material as determined by ASTM 01557.

1.4 QUALITY ASSURANCE

- A. Regulatory Requirements:
 - 1. Comply with rules and regulations of local and State agencies having jurisdiction.
 - 2. Comply with State and local code requirements for disposal of debris.
- B. Allowable Tolerances:
 - 1. Excavations shall not exceed 1/10-foot variation from dimensions and elevations shown or noted on plans.
 - 2. Fill and backfill shall be placed within tolerance of plus or minus 1/10-foot.

1.5 PROJECT CONDITIONS

- A. Existing Conditions:
 - 1. Carefully maintain bench marks, monuments, and survey control references.
 - 2. Verify or determine locations of underground utilities and avoid damage. Should damage occur, notify the Architect and repair at no additional cost to the Contract.
 - 3. Restore grades disturbed by construction activity or other causes to elevations shown or noted.
- B. Environmental Requirements: When unfavorable weather conditions necessitate interrupting filling and grading operations, prepare areas by compaction of surface and grading to avoid collection of water. Provide adequate temporary drainage to prevent erosion. After interruption, re-establish compaction specified in last layer before resuming work.
- C. Protection: Conduct earthwork operations so as to prevent windblown dust and dirt from interfering with the Owner's and adjacent property owner's normal operations. Assume liability for all claims related to windblown dust and dirt. Protect building structures and adjacent surfaces to remain.
- D. Sequencing: Sequence operations so as to maintain safe working conditions and preserve existing Work which is to remain.

- E. Layout: If any discrepancies are found by Surveyor between Drawings and actual conditions at Site, Architect reserves right to make such minor adjustments in Work specified hereunder, as are necessary to accomplish the intent of the Contract Documents, at no increase in Contract price.

1.6 RECORDS OF INVESTIGATION

- A. The following record of investigation is available as a reference for the Contractor:
 - 1. Title: Geotechnical Investigation Report and Geologic Hazard Assessment, Liberty High School Campus Expansion
 - 2. Author: BSK Associates
 - 3. Date: April 11, 2018
 - 4. Availability: Available for reference at the offices of the author of the report and the Architect.

1.7 RESPONSIBILITY FOR ACCURACY OF SITE DATA

- A. The Contractor shall promptly, and before such condition is disturbed, notify the Architect in writing of soil or subsurface conditions which differ materially from those conditions shown in the Contract Documents or in the records of investigations of soil or subsurface conditions referred to above. The Architect shall promptly investigate the conditions. If he finds the conditions materially different from those which reasonably should have been anticipated on the basis of a careful consideration of said records of investigations, logs of borings and examination of the site, and finds that said conditions will cause an increase or decrease in the cost of, and/or the time required for performance of the Contract, he will, after approval by the Owner, modify the Contract Terms in writing to provide for an equitable adjustment in cost and/or time of performance. Any claim of the Contractor shall not be allowed unless he has given the required written notice.

PART 2 - PRODUCTS

1.1 MATERIALS

- A. All earthwork shall be in conformance with the soils report.
- B. Typical Fill and Backfill:
 - 1. Granular, not showing excessive shrinkage or swelling when subjected to changes in water content.
 - 2. Free of organic matter and other deleterious substances and containing no rocks or lumps over 3-inches in greatest dimension.
 - 3. All fill material shall be moisture conditioned to at least 3-percent over optimum moisture content as determined by ASTM D1557.
 - 4. On-site soils may be used as fill material except where granular fill material is specified. The moisture content must be within the above limits to be acceptable. Some drying of on-site soils may be required.
 - 5. Conform to the following minimum requirements:
 - (a) Maximum Plasticity Index: 15.
 - (b) Liquid Limit: Less than 30%.
 - (c) % Passing #200 Sieve: 8% - 40%

PART 3 - EXECUTION

1.1 INSPECTION

- A. The Contractor shall be deemed to have inspected site and informed himself of actual grades, levels, and other conditions under which Work is to be performed.

1.2 EXCAVATION

- A. All earthwork shall be in conformance with the soils report.
- B. General Requirements:
 - 1. Excavate to dimensions and elevations shown or noted with bottoms square and true.
 - 2. Remove debris, old foundations, tree stumps, and loose rocks from bottom of excavation.
 - 3. Shore, brace, sheet, and slope excavations as required to prevent caving, erosion, danger to persons and structures, or interference with construction operations and as required to comply with safety laws.

4. Keep excavation free of water at all times until concrete work and backfilling is complete. Grade excavated areas to provide drainage to prevent ponding of water.
- C. Excavated Soil Material: All excavated material determined unsuitable for use as fill or backfill or in excess of backfill requirements shall be removed from the site.
- D. Provisions for Formwork Construction:
1. Extend excavations sufficient distance from walls and footings to permit placing and removal of forms, installation of services and inspection.
 2. Trim excavation walls and bottoms to reasonably smooth lines and grades.
- E. Earth Forms: The Contractor may excavate to dimensions of footing required in order to avoid constructing formwork, provided excavations are clean cut and free of spaces or cave-ins and provided the Owner's Soils Engineer approves. Continuous trenching for individual footings will not be permitted.
- F. Over-Depth Excavations: Rebuild to grade with lean concrete as directed by the Owner's Soils Engineer.
- G. Topsoil: Strip topsoil as directed by the Owner's Soils Engineer at the time of grading. The Contractor shall stockpile topsoil on the site as directed.
- H. Removal of On- or Below-Grade Construction or Obstructions:
1. Remove known existing construction or obstructions including wells, vaults, walls, or otherwise enclosed spaces wherever they occur below new grade within immediate areas of new construction, new paving or new planted areas.
- I. Reworking of Holes, Depressions, Softened, or Disturbed Areas:
1. Cut out the hole, depression, or unsuitable soil area to workable "cat" width or wider by use of "cat and blade" or similar means, cutting to firm subgrade at the bottom and sides.
 2. Compact the subgrade as specified hereinbefore.
 3. Fill as specified for structural backfill. "Hook" into the side of the excavation as each lift or fill is spread, as far as may be required to reach firm soil at the sides of the excavation and to bond new fill into the existing soil.
 4. Fill excavation in manner specified hereinbefore until a surface is obtained which is even and continuous with adjoining grade and offers a firm, even subgrade for final usage or placement of additional fill thereon.

- J. Dewatering:
 - 1. Provide, operate, and remove dewatering equipment necessary to drain and keep excavations free of water under all circumstances.
 - 2. Prevent surface water from flowing into excavation; promptly remove any water accumulated.
 - 3. Dewatering system shall remain in place until construction Work below groundwater table is completed.

1.3 FILLING AND BACKFILLING

- A. All earthwork shall be in conformance with the soils report.
- B. General Requirements:
 - 1. Do not place fill or backfill until forms, rubbish and deleterious materials have been removed, waterproofing measures completed, and areas have been approved by the Architect.
 - 2. Scarify surface of area to receive fill to 12-inch depth and until surface is free from ruts, hummocks or other uneven features. Disc or blade scarify surface until free from large clods.
 - 3. Bring scarified material to proper moisture content and compact to specified density.
 - 4. Spread material in layers not to exceed 8-inch depth before compaction. Sprinkle material with sufficient moisture to compact properly; permit material with excess moisture to dry to proper water content. Thoroughly mix soil and water by blading and discing before compacting.
 - 5. Place granular backfill material as adjacent backfill is being placed.
 - 6. Adequately brace and shore footings, walls, etc., against which backfill is to be placed to prevent displacement or damage during placement. Do not remove shores or braces until permanent supports are in place and have attained their required strength.
 - 7. All fill material should be within 3-percent of optimum moisture contents as determined by ASTM 01557.
- C. Minimum Compaction Requirements:
 - 1. Subgrade under interior slabs: 90-percent
 - 2. Subgrade under footings: 90-percent

3. Subgrade under pavements supporting automobile traffic: 95-percent
 4. All other fills: 90-percent
 5. Do not compact soil in planting areas.
- D. Compacting:
1. Compact by power tamping, rolling or combinations thereof as approved by the Owner's Soils Engineer. Where impractical to use rollers in close proximity to walls, stairs, etc., compact by mechanical tamping. Scarify and recompact any layer not attaining compaction until required density is obtained.
 2. Compaction by flooding, ponding or jetting will not be permitted.

1.4 SLAB BASE AND VAPOR RETARDER INSTALLATION

- A. All earthwork shall be in conformance with the soils report.
- B. Rock Courses:
1. Verify that all improvements such as floor drains are installed.
 2. Verify that the Owner's Soils Engineer has approved rough graded and compacted subgrade.
 3. Place nominal 6-inch thick rock course under building slabs.
 4. Level and compact to smooth surface.
- C. Vapor Retarder Installation: Place vapor retarder sheeting with longest parallel with direction of pour. Lap seams 6" minimum and seal with manufacturer's recommended tape.

1.5 GRADING

- A. All earthwork shall be in conformance with the soils report.
- B. Begin grading only after debris and construction materials are removed from area concerned.
- C. Grade areas to smooth, level or evenly sloped, uniform surface in conformity to contour lines and spot elevations noted. Make grades level where not otherwise indicated. Round smooth abrupt changes in slopes. Refill to required levels any settled grades. Slope ground away from building walls.
- D. Ensure finished grades and surfaces conduct water directly to area drain, gutters, etc.
- E. Place stockpiled topsoil in maximum 6-inch lifts to depth indicated. Scarify subgrade to minimum depth of 6-inches and obtain the Architect's approval before placing topsoil. Topsoil shall not be used for engineered fill.

- F. Prevent erosion of freshly graded areas during construction and until permanent drainage and erosion control measures are installed. At cut slopes, place layer mesh and plant ground cover.
- G. After finish grading is completed, perform no further excavation or filling operations except by the Architect's approval and under observation of the Owner's Soils Engineer.

1.6 FIELD QUALITY CONTROL

- A. The Owner's Soils Engineer will:
 - 1. Sample and test fill material from source designated by the Contractor.
 - 2. Observe site preparation, excavation and placing and compacting of fill and backfill.
 - 3. Perform tests and inspections deemed necessary to ensure compliance with specifications.
 - 4. Issue final report to the Owner on grading and certification of compliance with specifications.
 - 5. Submit verified report to the DSA per CBC Section 1704A.
- B. The Contractor shall:
 - 1. Furnish access to site and facilities for inspection.
 - 2. Notify the Soils Engineer 48-hours prior to any fill or backfill operations.
 - 3. Pay costs for additional inspections and tests due to noncompliance with Contract Documents.

END OF SECTION 31 2000

SECTION 31 2313

**SUBGRADE PREPARATION & BASE
MATERIAL**

PART 1 - GENERAL

1.1 DESCRIPTION

- A. Provide subgrade preparation and the base material installation complete, including clearing, grading, excavation, filling and compaction and dewatering.
- B. Subgrade is that area on which concrete, aggregate base, or layer of any other non-organic material is to be placed.

1.2 QUALITY ASSURANCE

- A. Reference Standards
 - 1. Perform all work in accordance with all applicable laws, codes and regulations required by the City of Brentwood, and County of Contra Costa.
 - 2. Perform work in accordance to applicable sections of the Caltrans Standard Specifications.
 - 3. Reference to "Caltrans Standard Specifications" shall mean the Standard Specifications of the State of California, Business and Transportation Agency, Department of Transportation, CALTRANS.
- B. Related work specified elsewhere includes:
 - 1. Section 31 2000, Earthwork
 - 2. Section 32 1216, Asphalt Concrete Paving
 - 3. Section 03 1313, Concrete
- C. Stipulations
 - 1. The finished surface of the subgrade, at any point, shall not vary more than 0.05' above or below the elevation indicated on the drawings.
 - 2. Finish Surface Tolerance: 1/4-inch maximum variation in 10 feet.
- D. ASTM Standards.

1.3 SUBMITTALS

- A. Provisions: Comply with Division 1 Requirements.
- B. Material list and product data of all items proposed to be provided under this Section.

- C. Certificates (certified analysis of certificate of compliance) signed by the material producer.

1.4 PROJECT CONDITIONS

- A. Coordination: Coordinate this work with the work of other Sections to avoid delay and interference with other work.

1.5 SOILS REPORT:

- A. A soil investigation report has prepared for the project by the firm of BSK, entitled:
 - 1. Geotechnical Investigation Report and Geologic Hazard Assessment, Liberty High School Campus Expansions by BSK dated April 11, 2018.
- B. This report is available in the office of the Architect and the Construction Manager for inspection by the Contractor. Unless otherwise specified, it is intended that all work be performed in accordance with the provisions of these report.

1.6 SOILS BORINGS

- A. Subsurface soils investigations have been made at the site and logs of the test holes are available with the soils report. Such investigations have been made for the purposes of design only, and neither the Architect, the Owner, nor the Soils Engineers guarantee adequacy or accuracy of the data, or that data are representative of all conditions to be encountered. Such information is made available for general information only and shall not relieve the Contractor of the responsibility for making his own investigations

1.7 PROJECT CONDITIONS

- A. Coordination: Coordinate this work with the work of other Sections to avoid delay and interference with other work.
- B. Protect excavations by shoring, bracing, sheeting, underpinning, or other methods as required to prevent cave-ins or loose dirt from entering excavations. Barricade open excavations and post warning signs at work adjacent to public streets and walks.
- C. Underpin adjacent structure(s), including utility service lines, which may be damaged by excavation operations.
- D. Promptly repair damage to adjacent facilities caused by earthwork operations. Cost of repair at Contractor's expense.
- E. Promptly notify the Inspector of unexpected subsurface conditions.
- F. If during the course of operations, an area of pumping or otherwise unstable soil is

encountered, the contractor shall immediately modify his operations in such a way as to limit the frequency and weight of vehicles traveling over the area and promptly notify the Inspector who will contact the Geotechnical Engineer for an evaluation.

1.8 EXISTING CONDITIONS

- A. A topographic survey of the property has been included in the drawings for reference only. Upon beginning the work, Contractor represents that he has inspected the site and satisfied himself as to actual grades and levels and the true conditions under which the work is to be performed.

1.9 PROTECTION

- A. Furnish, place and maintain all supports, shoring and sheet piling which may be disturbed by earthwork operations.
- B. Maintain all benchmarks, monuments, and other reference points. If disturbed or destroyed, replace as directed.
- C. Adequate protection measures shall be provided to protect workmen, passers-by, and the site. Streets and adjacent property shall be fully protected throughout the operations.
- D. In accordance with generally accepted construction practices, the Contractor shall be solely and completely responsible for working conditions on the job site, including safety of all persons and property during performance of the work. This requirement shall apply continuously and not be limited to normal working hours.
- E. Any construction review of the Contractor's performance conducted by the Inspector is not intended to include review of the adequacy of the Contractor's safety measures in, on, or near the construction site.
- F. Adjacent streets, sidewalks, and property shall be kept free of mud, dirt, or similar nuisances resulting from earthwork operations.
- G. Provide for surface drainage during the period of construction in a manner to avoid creating a nuisance to adjacent areas.
- H. Water as required to suppress dust nuisance.
- I. Protection of Existing Improvements
 - 1. Provide barricades, covering, or other types of protection necessary to prevent damage to existing improvements indicated to remain in place. Protect improvements on adjoining properties. Repair damaged existing

improvements to original condition as approved by authority having jurisdiction.

- J. Provide erosion control measures as required.
- K. Protection of Other Property: Excavation and other work over, under and adjacent to existing pipelines, cables, conduit runs or structures of any kind shall be procured in such a manner as not to interfere with the safe operation and use of such installations . Should any damage be incurred to existing facilities during the Contractor's operations, the Contractor shall immediately notify the Owner's Representative and authorities, and shall arrange for the immediate repair of same at his own expense.
- L. Underground Obstruction: The locations of existing underground utilities and structures, insofar as they are known from information furnished by the respective utility companies and agencies, have been shown on the drawings. The Owner assumes no responsibility for the accuracy or completeness of said data, which is offered solely for the convenience of the Contractor.
- M. Control of Water: Take measures as may be required and furnish, install and operate such pumps or other devices as may be necessary to remove any seepage, storm water or sewage that may be found or may accumulate in the excavations during the progress of the work. Keep excavations entirely free from water at all times during the construction of the work, and until the Geotechnical Engineer gives permission to cease pumping.
- N. Pavement Restoration: Pavement, bases and compacted subgrade disturbed by trenching operations shall be replaced in an acceptable manner with materials equal to the adjacent compacted subgrade, bases and pavement for a minimum distance of 12" on each side of the trench, and shall conform to the requirements of these Specifications or to local ordinances governing such replacement.

1.10 FIELD QUALITY CONTROL

- A. Contractor shall provide adequate notice, cooperate with, provide access to the work, and assist testing agency and their representatives in execution of their function.
- B. When, during the progress of work, field tests indicate that installed compacted materials do not meet specified requirements, provide additional compaction until specified density is achieved, or remove and replace defective materials with new

materials as directed by the Inspector. Cost of additional labor, materials, and testing to attain specified density at Contractor's expense.

- C. The Contractor shall engage a California Registered Civil Engineer or licensed Land Surveyor to perform field engineering.

1.11 TESTING

- A. Testing and Inspection: Testing shall be performed by a qualified independent testing laboratory under the supervision of a registered professional engineer, specializing in soils engineering.
- B. The Owner will direct, provide and pay for initial testing and inspection during operations.
- C. Provide and pay for re-testing and inspection during operations. Laboratory and inspection service shall be acceptable to the Owner.
- D. Where reference is made to relative compaction, it shall be the in-place dry density of soil expressed as a percentage of the maximum dry density of the same material, determined by the ASTM 01557 laboratory test procedure. Optimum moisture is the water content that corresponds to the maximum dry density.
- E. For structural fills under footings, slabs or pavements, determine moisture-density relationships in accordance with ASTM 01557.
- F. Plasticity Index: ASTM 4318-98.

1.12 GENERAL REQUIREMENTS

- A. When rain is forecast, temporary measures to protect areas of the exposed subgrade from saturation by rainfall or runoff shall be taken. These include, but are not limited to, covering grading and sloping of subgrade surfaces to prevent ponding, sealing disturbed, uneven subgrade, surfaces with a smooth drum roller, grading and excavating diversionary swales, trenches or detention basins.
- B. Failure by the Contractor to comply with the above requirements to take reasonable and adequate measures or exercise sound engineering and construction practices to protect the work from damage. All repair work shall be performed at no additional cost to the Owner.

PART 2 - MATERIALS

2.1 AGGREGATE BASE - CLASS 2

- A. Aggregate base shall be Class 2, and free from vegetable matter or other deleterious substances. The percentage composition by weight of aggregate base shall conform

to Section 26 of the Caltrans Standard Specifications.

2.2 RECYCLED AGGREGATE BASE - CLASS 2

- A. Subject to the approval of the Geotechnical Engineer, recycled aggregate base shall be Class 2, and free from vegetable matter or other deleterious substances. The percentage composition by weight of aggregate base shall conform to Section 26 of the Caltrans Standard Specifications.
- B. Recycled aggregate compliant with the above provisions is acceptable for onsite work only. In accordance with City of Brentwood prohibitions, no recycled aggregate shall be used for off-site work in the public right-of-way.

PART 3 - EXECUTION

3.1 SUBGRADE PREPARATION

- A. Remove topsoil, stumps, roots, grasses and weeds to the satisfaction of the Geotechnical Engineer.
- B. Scarify subgrade to a depth specified in the geotechnical report.
- C. Remove all boulders, hardened material or rock encountered that is over 3 inches in size. The earth shall be uniform for the full depth and width of the subgrade.
- D. Lime treat the subgrade 12" deep per the Geotechnical Engineer's recommendations. Refer to the geotechnical report.
- E. The proper moisture condition and compaction per the geotechnical report.
- F. Relative compaction, maximum dry density, and optimum moisture content of fill materials shall be determined in accordance with ASTM Test Method D1557, "Moisture-Density Relations of Soils and Soil Aggregate Mixtures Using a 10-lb. Rammer and 18-in. Drop.
- G. The finished subgrade surface shall be firm and unyielding under the weight of a loaded water truck traveling over the surface.

3.2 AGGREGATE BASE

- A. Deliver to site as a uniform mixture and spread each layer in one operation without segregation.
 - 1. Class 2 Aggregate Base shall be readily compacted and spread with equipment that will provide a uniform layer conforming to the planned section, and as specified in Section 26 of the Caltrans Standard Specifications.
- B. The aggregate base shall be compacted to at least 95 percent relative compaction.

1. Proof roll and mark "soft spots" for additional compaction or correction. Proof rolling operations must be performed in the presence of a Geotechnical Engineer.
- C. Unsatisfactory material shall be removed and repaired to the satisfaction of the Geotechnical Engineer.

END OF SECTION 31 2313

SECTION 31 2333

TRENCHING AND BACKFILL

PART 1 - GENERAL

1.1 RELATED DOCUMENTS

- A. Drawings and general provisions of the Contract, including General and Supplementary Conditions and Division 1 Specification Sections, apply to this Section.

1.2 SUMMARY

- A. Section includes:
 - 1. Excavating and backfilling for utility trenches.
- B. Related Sections include:
 - 1. Section 31 2000 "Earthwork" for
 - (a) Preparing subgrades for slabs-on-grade, walks, pavements, lawns, and grasses, and exterior plants.
 - (b) Excavating and backfilling for buildings and structures.
 - 2. Section 22 1100 "Site Water Distribution" for underground water lines outside of buildings.
 - 3. Section 22 3100 "Site Sanitary Sewer" for underground sewer lines outside of buildings.
 - 4. Section 33 4000 "Site Storm Drainage" for underground storm drain lines.
 - 5. Division 26 Section for underground electrical conduits.

1.3 DEFINITIONS

- A. Backfill: Soil material or controlled low-strength material used to fill an excavation.
 - 1. Initial Backfill: Backfill placed beside and over pipe in a trench, including haunches to support sides of pipe.
 - 2. Final Backfill: Backfill placed over initial backfill to fill a trench.
- B. Base Course: Course placed between the subgrade and surface pavement in a paving system.
- C. Bedding Course: Course placed over the excavated subgrade in a trench before laying pipe and initial backfill over pipe and conduit.
- D. Borrow Soil: Satisfactory soil imported from off-site for use as fill or backfill.

- E. Excavation: Removal of material encountered above subgrade elevations and to lines and dimensions indicated.
 - 1. Authorized Additional Excavation: Excavation below subgrade elevations or beyond indicated lines and dimensions as directed by Architect. Authorized additional excavation and replacement material will be paid for according to Contract provisions for changes in the Work.
 - 2. Unauthorized Excavation: Excavation below subgrade elevations or beyond indicated lines and dimensions without direction by Architect. Unauthorized excavation, as well as remedial work directed by Architect, shall be without additional compensation.
- F. Structures: Buildings, footings, foundations, retaining walls, slabs, tanks, curbs, mechanical and electrical appurtenances, or other man-made stationary features constructed above or below the ground surface.
- G. Subgrade: Surface or elevation remaining after completing excavation, or top surface of a fill or backfill immediately below base course, drainage course, or topsoil materials.
- H. Utilities: On-site underground pipes, conduits, ducts, and cables, as well as underground services within buildings.

1.4 SUBMITTALS

- A. Product Data: For the following:
 - 1. Each type of plastic warning tape.
- B. Soil Samples: As required by Owner's Geotechnical Engineer for sampling and testing of proposed offsite borrow soil material.
 - 1. Deliver a representative sample of each type of imported borrow material to Owner's geotechnical testing agency's laboratory at least 7 days prior to delivery to site, for evaluation and testing.
- C. Material Test Report: From a qualified testing agency indicating and interpreting test results for compliance of the following with requirements indicated:
 - 1. Classification according to ASTM D 2487 of each on-site and borrow soil material proposed for fill and backfill.
 - 2. Laboratory compaction curve according to ASTM D 1557 for each on-site and borrow soil material proposed for fill and backfill.

1.5 QUALITY ASSURANCE

- A. Geotechnical Testing and Inspection: Owner will employ and pay for a qualified independent geotechnical testing and inspection agency to perform soils testing and inspection services during utility trenching and backfill operations. All imported borrow materials must be approved by Owner's geotechnical testing agency.

1.6 PROJECT CONDITIONS

- A. Site Information: Data in subsurface investigation reports was used for the basis of the design and is available to Contractor for information, only. Conditions are not intended as representations or warranties of accuracy or continuity between soil borings.
- B. Existing Utilities: Locate existing underground utilities in areas of excavation work. If utilities are indicated to remain in place, provide adequate means of support and protection during earthwork operations.
 - 1. Should uncharted or incorrectly charted piping or other utilities be encountered during excavation, consult utility owner immediately for directions. Cooperate with Owner and utility companies in keeping respective services and facilities in operation, if required. Repair damaged utilities to satisfaction of utility owner.
 - 2. Do not interrupt existing utilities serving facilities occupied by Owner or others unless permitted under the following conditions and then only after arranging to provide temporary utility services according to requirements indicated:
 - (a) Notify Architect not less than five working days in advance of proposed utility interruptions.
 - (b) Do not proceed with utility interruptions without Architect's written permission.
 - 3. Demolish and completely remove from site existing underground utilities identified for removal. Coordinate with utility companies for shutoff of services if lines are active.
- C. Use of explosives is not permitted.
- D. Protection of Persons and Property:
 - 1. Barricade open excavations and post with warning lights as per requirements of authorities having jurisdiction.
 - (a) Conform to all applicable occupational safety regulations.

2. Protect structures, utilities, sidewalks, pavements, and other facilities from damage caused by settlement, lateral movement, undermining, washout, and other hazards created by earthwork operations.
 3. Excavation within drip line of trees to remain to be performed by hand. Protect root systems from damage or dry out to the greatest extent possible. Maintain moist condition for root system and cover exposed roots with moistened burlap. Refer to Section 02235 "Tree Protection and Trimming" for additional requirements.
- E. Dust Control: Conduct earthwork operations so as to prevent windblown dust and dirt from interfering with Owner's and adjacent property owners' normal operations.

PART 2 - PRODUCTS

2.1 SOIL MATERIALS

- A. General: Provide borrow soil materials when sufficient satisfactory soil materials are not available from excavations.
- B. Satisfactory Soils: As specified in Section 02300 "Site Earthwork," and free of debris, waste, frozen materials, vegetation, and other deleterious matter.
 1. Onsite native soils below the stripped layer having an organic content of less than 3 percent by weight are suitable for use as backfill at utility trenches.
- C. Bedding Course: Naturally or artificially graded mixture of natural or crushed gravel, crushed stone, and natural or crushed sand; ASTM D 2940; except with 100 percent passing a 1-inch sieve and not more than 8 percent passing a No. 200 sieve.

2.2 MISCELLANEOUS MATERIALS

- A. Concrete: Normal-weight concrete with not less than 3,000-psi compressive strength (28 days), 3-inch slump. Measure, batch, and mix according to ASTM C 94.
 1. Portland Cement: ASTM C 150, Type I or II.
 2. Aggregate: ASTM C 33; 1-inch maximum size.
 3. Water: ASTM C 94; potable.

2.3 ACCESSORIES

- A. Detectable Warning Tape: Acid-resistant and alkali-resistant polyethylene film warning tape manufactured for marking and identifying underground utilities, a minimum of 6 inches wide and 4 mils thick, continuously inscribed with a description of the utility,

with metallic core encased in a protective jacket for corrosion protection, detectable by metal detector when tape is buried up to 30 inches deep; colored as follows:

1. Red: Electric.
2. Yellow: Gas, oil, steam, and dangerous materials.
3. Orange: Telephone and other communications.
4. Blue: Water systems.
5. Green: Storm and sewer systems.

PART 3 - EXECUTION

1.1 PREPARATION

- A. Protect structures, utilities, sidewalks, pavements, and other facilities from damage caused by settlement, lateral movement, undermining, washout, and other hazards created by earthwork operations.
- B. Provide erosion-control measures to prevent erosion or displacement of soils and discharge of soil-bearing water runoff or airborne dust to adjacent properties and walkways.

1.2 DEWATERING

- A. Prevent surface water and ground water from entering excavations, from ponding on prepared subgrades, and from flooding Project site and surrounding area.
- B. Protect subgrades from softening, undermining, washout, and damage caused by rain or water accumulation.

1.3 EXCAVATION, GENERAL

- A. Do not use explosives.
- B. Unclassified Excavation: Excavation is unclassified and includes excavation to required subgrade elevations regardless of the character of materials and obstructions encountered.
- C. Stability of Excavations:
 1. Comply with all applicable local codes, ordinances, and requirements of authorities having jurisdiction to maintain stable excavations. Maintaining stability of excavations is sole responsibility of Contractor.
 - (a) Support all trench and other excavations in accordance with California Code of Regulations, Title 8 -Industrial Relations (Cal/OSHA

Standards), Chapter 4 - Division of Industrial Safety, Subchapter 4 -
Construction Safety Orders.

1.4 EXCAVATIONS FOR UTILITY TRENCHES

- A. Excavate trenches to indicated gradients, lines, depths, and elevations.
 - 1. Beyond building perimeter, excavate trenches to allow installation of top of pipe below frost line.
 - 2. Where trench runs parallel to perimeter edge of adjacent structure, do not locate trench excavations within distance to structure, such that any portion of structure, including footings, will occur above a plane projected upward at a slope of one vertical to two horizontal from any point in the excavation.
- B. Excavate trenches to uniform widths to provide the following clearance on each side of pipe or conduit. Excavate trench walls vertically from trench bottom to 12 inches higher than top of pipe or conduit, unless otherwise indicated.
 - 1. Clearance: 12 inches each side of pipe or conduit, or as otherwise indicated.
- C. Trench Bottoms: Excavate trenches 6 inches deeper than bottom of pipe elevation to allow for bedding course. Hand excavate for bell of pipe.

1.5 SUBGRADE INSPECTION

- A. Notify Architect and Geotechnical Engineer when excavations have reached required subgrade.
- B. If Geotechnical Engineer determines that unsatisfactory soil is present, continue excavation and replace with compacted backfill or fill material as directed.
- C. Reconstruct subgrades damaged by freezing temperatures, frost, rain, accumulated water, or construction activities, as directed by Architect and Geotechnical Engineer, without additional compensation.

1.6 STORAGE OF SOIL MATERIALS

- A. Stockpile borrow soil materials and excavated satisfactory soil materials without intermixing. Place, grade, and shape stockpiles to drain surface water. Cover to prevent windblown dust and saturation from rain.
 - 1. Stockpile soil materials away from edge of excavations. Do not store within drip line of remaining trees.

2. Dispose of excess excavated soil material and materials not acceptable for use as backfill or fill. Comply with all applicable state and local requirements for offsite disposal of soil and other waste materials.

1.7 UTILITY TRENCH BACKFILL

- A. Place and compact backfill in excavations promptly, but not before completing the following:
 1. Surveying locations of underground utilities for Record Documents.
 2. Testing, inspecting, and approval of underground utilities.
 3. Removal of trash and debris from excavation.
 4. Removal of temporary shoring and bracing, and sheeting.
- B. Place bedding and backfill material on subgrades free of mud, frost, snow, and ice. Remove vegetation, topsoil, debris, wet and unsatisfactory soil materials, obstructions, and deleterious materials from ground surface prior to placing backfill materials.
- C. Place and compact bedding course 6 inches in depth on trench bottoms. Shape bedding course to provide continuous support for bells, joints, and barrels of pipes and for joints, fittings, and bodies of conduits.
 1. Prevent displacement of piping or conduit by placing and compacting material uniformly around piping or conduit to approximately same elevation in each lift.
 2. Place bedding material to an elevation of 12 inches above top of pipe or conduit.
- D. Use satisfactory soil material for trench backfill.
- E. Trenches Under Footings: Where trenches pass under footings or are excavated within 18 inches of footings, fill to elevation of bottom of footings with concrete.
- F. Placement and Compaction of Bedding and Backfill Material: Place to final subgrade elevation.
 1. Place backfill materials in layers not more than 8 inches in loose depth.
 2. Soil Moisture Control: Uniformly moisten or aerate subgrade and each subsequent backfill soil layer before compaction to levels indicated.
 3. Compact each layer of bedding material and backfill soil material at 95 percent relative compaction at a moisture content of 3 to 5 percent above laboratory optimum value, according to ASTM D 1557, except as follows:

- (a) Where occurring within turf or planted areas, compact upper 18 inches of backfill soil material at 85 percent relative compaction at a moisture content of 3 to 5 percent above laboratory optimum value.
- 4. Correct improperly compacted areas or lifts as directed by Architect or Geotechnical Engineer if soil density tests indicate inadequate compaction.
- G. Install warning tape directly above utilities, 12 inches below finished grade, except 6 inches below subgrade under pavements and slabs.

1.8 PAVEMENT BASE COURSES

- A. Place base courses under paved areas on prepared subgrade, in indicated thicknesses, or if not indicated, to match thickness of existing base course, and as specified in Section 32 1216 "Asphalt Concrete Paving."

1.9 FIELD QUALITY CONTROL

- A. Testing Agency: Owner will engage a qualified independent geotechnical engineering testing agency to perform field quality-control testing.
 - 1. Notify Owner's testing agency at least 2 working days prior to date when observation and testing services are needed.
- B. Allow testing agency to inspect and test subgrades and each fill or backfill layer. Proceed with subsequent earthwork only after test results for previously completed work comply with requirements.
- C. Testing agency will test compaction of soils in place according to ASTM D 1556, ASTM D 2167, ASTM D 2922, and ASTM D 2937, as applicable. Tests will be performed at the following locations and frequencies:
 - 1. Trench Backfill: At each compacted initial and final backfill layer, at least one test for each 150 feet or less of trench length, at a frequency of no less than 18 inches vertically, but no fewer than two tests.
- D. When testing agency reports that subgrades, fills, or backfills have not achieved degree of compaction specified, scarify and moisten or aerate, or remove and replace soil to depth required; recompact and retest until specified compaction is obtained.
 - 1. Additional testing and inspection required by failure to meet specified requirements will be at Contractor's expense.

1.10 PROTECTION

- A. Where settling occurs before Project correction period elapses, remove finished surfacing, backfill with additional soil material, compact, and reconstruct surfacing.
 - 1. Restore appearance, quality, and condition of finished surfacing to match adjacent work, and eliminate evidence of restoration to greatest extent possible.

1.11 DISPOSAL OF SURPLUS AND WASTE MATERIALS

- A. Disposal: Remove surplus satisfactory soil and waste material, including unsatisfactory soil, trash, debris, and legally dispose of it off Owner's property.

END OF SECTION 31 2333

SECTION 32 1216

ASPHALT CONCRETE PAVING

PART 1 - GENERAL

1.1 RELATED DOCUMENTS

- A. Drawings and general provisions of the Contract, including General and Supplementary Conditions and Division 1 Specification Sections, apply to this Section.

1.2 SUMMARY

- A. Work Included: Furnish all labor, materials, equipment, facilities, transportation and services to complete all asphaltic concrete paving operations including the preparation and paving of new areas, paving overlays, patch paving of all existing paved areas disturbed by construction and related work as shown on the drawings and/or specified herein.
- B. Related Sections include:
 - 1. Section 31 2000: Earthwork
 - 2. Section 31 2333: Trenching and Backfilling
- C. References:
 - 1. Sections and chapters of Standard Specifications mentioned herein refer to Standard Specifications, State of California, Department of Public Works, Division of Highways, Latest Edition.

1.3 SUBMITTALS

- A. Provide owner with complete materials listing for approval. Materials certificates shall be signed by the material producer and the Contractor, certifying that each material item complies with or exceeds specified requirements.

1.4 DELIVERY, STORAGE, AND HANDLING

- A. Comply with pertinent provisions of Section , Material, Equipment and Substitutions.
- B. Engineering fabrics shall be furnished in protective covers capable of protecting the fabric from ultraviolet rays, abrasion, and water.

1.5 PROJECT CONDITIONS

- A. Weather Limitations
 - 1. Do not lay base course on muddy subgrade, during wet weather, or when atmospheric temperature is below 35 degrees Fahrenheit.

- 2. Do not apply asphaltic surfacing on wet base, during hot weather, or when atmosphere temperature is below 40 degrees Fahrenheit
- B. Grade Controls
 - 1. Establish and maintain required lines and grades, including crown and cross slope.

1.6 PERFORMANCE REQUIREMENTS

- A. Qualifications of asphalt concrete producer: Use materials that are furnished by bulk asphalt concrete producers regularly engaged in production of hot-mix, hot-laid asphalt concrete.
- B. Applicator qualification: Company specializing in the application of asphalt concrete paving.
- C. Asphalt concrete paving shall show no evidence of cracking, uneven settlement or improper drainage. Contractor will be responsible for correcting work displaying such conditions.
- D. Allowable tolerances: Finish surface shall be true to established elevations with 1/8" in ten feet as measured from a 10-foot straight edge in any direction.

PART 2 - PRODUCTS

2.1 STANDARDS

- A. Reference State of California Department of Transportation design methods of flexible pavements.

2.2 MATERIALS

- A. Aggregate Base: Aggregate base material and method of placing shall conform to Section 26 of the State Specifications excepting modifications as herein specified. The aggregate base shall conform to the grading providing for 3/4 inch maximum grading as shown herein.

| <u>Sieve Size</u> | <u>Percentage Passing</u> <u>Sieve By Weight</u> |
|-------------------|---|
| | 3/4" Max. |
| 2" | 100 |
| 1-1/2" | 100 |
| 3/4" | 90-100 |
| No. 4 | 35-55 |

| | |
|---------|-------|
| No. 30 | 10-30 |
| No. 200 | 2-9 |

- B. Asphaltic Concrete: Shall be Type "B" in conformance to Sections 39 and 92 of the State of California Specifications, except as herein modified:
 - 1. Aggregate for Asphaltic Concrete: Shall be a ½ inch maximum gradation for new pavement areas, medium grade.
- C. Asphalt Emulsion: Shall conform to Section 94 of the State Specifications.

PART 3 - EXECUTION

3.1 PLACEMENT OF AGGREGATE BASE

- A. The Contractor shall proof roll subbase prior to placement of aggregate base. If soft areas are encountered, the Contractor shall excavate backfill with aggregate base or suitable material and compact to 95%. The Contractor shall remove any loose material or debris. Prior to correction of any soft areas identified by proof rolling, a Change Order must be authorized by the Owner.
- B. Aggregate Base Method of Placing: The Contractor shall conform to Section 26 of the State Specifications excepting modification as herein specified.
- C. Aggregate Base shall be placed in 6" maximum lifts and each lift will be compacted to 95% relative compaction.
- D. The material will be deposited on the subgrade in such a manner as to provide a uniform section of material within five percent tolerance of the pre-determined required depth. Deposition will be by spreader box or bottom dump truck to prevent segregation of the material. The material so deposited on the subgrade shall have sufficient moisture, which in the opinion of the Soils Engineer, is adequate to prevent excessive segregation. It shall then be immediately spread to its planned grade and cross section. Undue segregation of material, excessive drifting or spotting of material will not be permitted and any material, in the opinion of the City and Owner, to be unsuitably segregated, shall be removed from the subgrade or completely reworked to provide the desired uniformity of the material.

3.2 PLACEMENT OF FRAMES, COVERS AND GRATES

- A. The Contractor shall set and adjust to finish grade all new and existing frames, covers, and grates of all manholes, drop inlets, drain boxes, valves, cleanouts, electrical boxes and other appurtenant structures prior to placement of asphaltic concrete.

3.3 ASPHALT CONCRETE

- A. The Asphalt Concrete method of placing shall conform to Sections 39 and 92 of the State Specifications, except as herein modified.
- B. Prior written approval of the City is required before the Contractor may place asphalt concrete without the use of paving machine. After compaction, the asphalt concrete shall have a density of not less than 95 percent (95%) of the maximum theoretical unit weight, as determined in the laboratory by Test Method No. Calif. 304.

3.4 ASPHALT EMULSION

- A. Asphalt Emulsion method of placing shall conform to Sections 37, 39 and 94 of the State Specifications.

END OF SECTION 32 1216

SECTION 32 1313
CONCRETE PAVING

PART 1 - GENERAL

1.1 DESCRIPTION

- A. Provide Portland cement concrete site work complete. including the following principal items:
 - 1. Concrete work shown on Civil Drawings.
- B. Related requirements include:
 - 1. Section 31 2000, Earthwork
 - 2. Section 31 2313, Subgrade Preparation and Base Material
 - 3. Section 32 1216, Asphalt Concrete Paving
 - 4. Division 2 – Related Deliverables

1.2 QUALITY ASSURANCE

- A. Reference and Standards
 - 1. Perform work in accordance with all applicable laws, codes and regulations required by City of Brentwood and County of Contra Costa and the State of California.
 - 2. Reference to "Standard Specifications" shall mean the current Standard Specifications of the State of California, Business and Transportation Agency, Department of Transportation, CALTRANS.
 - 3. The American Concrete Institute (ACI): "Manual of Concrete Practice," Parts 1, 2 and 3.
- B. Stipulations
 - 1. Finish Surface Tolerance: 1/4-inch maximum variation in 10 feet.

1.3 TESTS

- A. The Project Inspector will select a qualified testing laboratory to take samples for testing during the course of the work as considered necessary. The Owner will pay costs for such tests. Contractor shall cooperate in making tests and shall be responsible for notifying the designated laboratory in sufficient time to allow taking of samples at time of pour.
- B. Should tests show that concrete is below specified strength, Contractor shall remove all such concrete, as directed by the Project Inspector. Full cost of removal of low strength

concrete, its replacement with concrete of proper specified strength and testing, shall be borne by Contractor.

1.4 COORDINATION

- A. Coordinate items of other trades. Contractor shall be responsible for the proper installation of all accessories embedded in the concrete and for the provision of holes, openings, etc., necessary to the execution of the work of the trades.

1.5 SOILS REPORT

- A. A soil investigation report has prepared for the project by the firm of BSK, entitled:
 - 1. Geotechnical Investigation Report and Geologic Hazard Assessment, Liberty High School Campus Expansions by BSK dated April 11, 2018.
- B. This report is available in the office of the Landscape Architect and the Construction Manager for inspection by the Contractor. Unless otherwise specified, it is intended that all work be performed in accordance with the provisions of these report.

1.6 SOILS BORINGS

- A. Subsurface soils investigations have been made at the site and logs of the test holes are available with the soils report. Such investigations have been made for the purposes of design only, and neither the Landscape Architect, the Owner, nor the Soils Engineers guarantee adequacy or accuracy of the data, or that data are representative of all conditions to be encountered. Such information is made available for general information only and shall not relieve the Contractor of the responsibility for making his own investigations

1.7 SUBMITTALS

- A. Submittals per Division 1 requirements
- B. The Contractor's Testing Laboratory's certificate of compliance.
- C. The Contractor shall submit:
 - 1. Certified copies of mix designs for each concrete class specified including compressive strength test reports.
 - 2. Certification that materials meet requirements specified.
 - 3. Certification from vendor that samples originate from and are representative of each lot proposed for use.
- D. Mock-ups of all materials under this Division shall be supplied for testing as requested by the Architect

- E. Provide mockup of all concrete finishes, color and joints (with curing compound if any to be used) indicated on the drawings. Accepted mock-ups shall be kept at the job site to serve as a prerequisite for all finishes.

1.8 PRODUCT DELIVERY, STORAGE AND HANDLING

- A. Supply ready mixed concrete throughout. Batch mix and transport in accordance with ASTM C-94, "Specifications for Ready Mixed Concrete."
- B. Mix and deliver concrete in quantities that will permit immediate use only.
- C. Indiscriminate addition of water for any reason will be cause for rejection of the load. 2.

PART 2 - PRODUCTS

2.1 FORMWORK MATERIALS

- A. Forms shall be wood.
 - 1. Plywood: APA Plyform, Grade B-B, 5/8-inch thickness minimum.
 - 2. Lumber: Douglas fir, "Standard" grade or better (grade marks not required).
 - 3. Plywood: 5/8-inch thickness minimum. Use overlaid plywood complying with U.S. Product Standard PS-1 "A-C or B-B High Density Overlaid Concrete Form", Class 1. Panels to receive specified form sealer to ensure uniform finish of exposed surfaces
- B. Form Coatings: Knox-Crete, or equal.
- C. Form Ties: Burke "Penta-Tie," or equal, cone and rod type with 1-inch break-back. Do not use form ties on exposed concrete of seat walls.

2.2 REINFORCING MATERIALS

- A. Bar Reinforcement ASTM A615.
 - 1. #3 and smaller: Grade 40.
 - 2. #4 and larger: Grade 60.

2.3 CONCRETE MATERIALS

- A. Portland Cement: ASTM C150, Type II.
- B. Aggregate: ASTM C33.
 - 1. Coarse Aggregate: Normal weight; 3/4-inch maximum size; clean, uncoated, crushed aggregate, free of materials which cause staining or rust spots.
 - 2. Fine Aggregate: Clean, natural sand.
- C. Water: Clear and potable, free from deleterious impurities.

- D. Admixtures: Admixtures are optional, must be compatible with color pigments where required. Any proposed admixture shall comply with State Section 2603(b) 5 of Part 2, Title 24 CCR. Accelerating admixtures are not permitted.

2.4 CONCRETE MIXES

- A. Concrete mixes shall be accepted and shall be in accordance with CalTrans Standard Specifications Section 90. Unless otherwise noted, mix shall be Class "A," 3,000 psi, Type II Portland cement and 3/4- inch maximum aggregate.
- B. Lamp Black: Concrete for exposed "natural colored" concrete shall be darkened by the addition of accepted agents at the mixer. The proportion of lampblack or other accepted colorant, to a great extent dependent on the color of the cement used in the mix, shall be that required to properly darken the concrete to reduce glare, and shall be subject to the approval of the Project Inspector or as required by Landscape Architect. Provide mock-ups with a ratio of one pound of lamp black for each cubic yard of concrete or as otherwise approved.

2.5 ANCILLARY MATERIALS

- A. Expansion Joint Material
 - 3. Fiber Expansion Joint: A non-extruding resilient filler, saturated with high quality bituminous materials having preserving characteristics. W. R. Meadows or accepted equal. Conform to ASTM- 01751-83. Include Joint Sealant
- B. Curing Compound: ASTM C309, Water-base type, free of permanent color, oil or wax, or accepted equal. Curing compound shall be compatible with color pigments.
- C. Concrete Sealer: As manufactured by L. M. Scofield Co. or silicone-based, non-staining product such as Siloxane as manufactured by Prosoco and available from White Cap (415) 626-3750 and as accepted by Architect. Concrete Sealer shall be compatible with color pigments.
- D. Combination Curing Compound Concrete Sealer: W. R. Meadows Vocomp-20, (800-342-5976) or accepted equal. Combination Curing Compound. Combination Curing Compound Concrete Sealer shall be compatible with color pigments.
- E. Joint Sealant: W. R. Meadows or Sonneboum 2-part joint sealant or Sikaflex-1a elastomeric joint sealant or equal product. Available from Sika Corporation, Hayward (510) 487-2294. Color shall be as selected by Landscape Architect.

- F. Color of Concrete: Pigments for integral colored concrete as manufactured by Davis Colors, 800-356- 4848, applied at manufacturer's specified rates of application, or accepted equal

2.6 WATERPROOFING

- A. Subseal-60 Self-adhering Waterproofing Membrane available from MFM Building Products Corp or accepted equal.

2.7 TRUNCATED DOMES

- A. Detectable dome spacing and size to meet detail on Civil Drawings.
- B. Detectable warning devices to be color yellow conforming to Federal color number 33538.
- C. When placed on asphalt, adhesive type detectable warning surface may be installed in lieu of cast-in-place.

PART 3 - EXECUTION

3.1 GENERAL REQUIREMENTS

- A. Install all concrete work true to line and grade as indicated on the drawings.
- B. Correct irregularities to the satisfaction of the Project Inspector.

3.2 PREPARATION

- A. Take every precaution to obtain a subgrade of uniform bearing power by compaction to provide a firm base.
- B. Subgrade shall be kept moist and shall not be allowed to dry out before placement of concrete. Place no material on muddy subgrade.
- C. Aggregate base, where indicated, shall be placed and compacted in conformance with CalTrans Standard Specifications 26-1.04 and 26-1 .05.
- D. Obtain acceptance of subgrade from Project Inspector prior to placing steel and concrete.

3.3 FORMS

- A. Forms shall be constructed in accordance with ACI 347 and shall be of sufficient strength and sufficiently tight to prevent visible distortion or leakage of mortar and fines.
- B. Forms for exposed surfaces shall be designed to protect intended finish. Deflection of facing material between studs shall not exceed 0.0025 of the span. Facing material and pattern of joints shall be as accepted by the Architect.
- C. For vertical surface of wall footings below grade, clean-cut trench may be used in lieu of form if character of soil will permit installation without sluffing and width of concrete is increased at least 1 inch beyond indicated dimension of each face poured against earth.

- D. Curb and pavement edge forms shall extend full depth of concrete. Curves shall be formed with flexible metal or wood made up of thin laminations. Curve forms shall extend one stake space straight beyond tangent point.
- E. Maintain forms within the following tolerances.
 - 1. Top of Form: Plus or minus 1/8 inch in 10 feet and no abrupt variations; at required elevation to plus 3/8 inch.
 - 2. Face of Form: Plus or minus 1/4 inch in 10 feet longitudinal and no abrupt variations; perpendicular to surface plus or minus 1/8 inch.
- F. Obtain approval of formwork from Project Inspector prior to placing concrete. Forms may be reused upon cleaning and coating with parting compound to ensure separation from concrete without damage.

After concrete is placed, the following minimum times shall elapse before removal of forms.

- 1. Footing sides: 24 hours.
- 2. Mow bands, curbs and pads: 48 hours.

3.4 REINFORCEMENT

- A. All concrete shall be steel reinforced unless specifically noted to be "not reinforced." If no reinforcement is shown, reinforce in same manner as that shown in similar places.
- B. Fabricate and place reinforcement as indicated on the Drawings and in accordance with ACI "Detailing Manual" SP-66. No reinforcement shall be placed prior to distribution of the accepted shop drawings.
- C. Secure reinforcement in position by suitable supports and by wiring at intersections with tie wire. Supports shall be of sufficient number and strength to resist crushing or displacement under full load. Metal shall not extend to surface of concrete.
- D. At time of placing concrete, reinforcing shall be free of excessive rust, mill scale, or other bond reducing matter. Immediately before placing concrete. check and adjust position, support and anchorage.

3.5 MIXING AND PLACING CONCRETE

- A. Conform to applicable requirements set forth in CalTrans Standard Specifications Section 90.

3.6 JOINTS AND GROOVES

- A. Plane of joints shall be perpendicular to surface. Where new pavements join existing, joints shall align.
- B. Install joint sealant at fiber expansion joints per manufacturer's specifications.
- C. Construction Joints: Place construction joints at the end of pours and at locations where placement operations are stopped for a period of more than one half hour, except where such pours terminate at expansion joints.
 - 1. Construction joints shall be keyed with formed tongue and groove.
 - 2. Tool concrete edge both sides of construction joint.
- D. Saw Cut Joints: Begin as soon as concrete has hardened enough to support saw and operator, and to allow cutting without raveling, or deforming the surface finish. Use a concrete cutting blade. Form a smooth uniform joint 1/8" wide, to 1" depth unless shown otherwise. Joints shall be cut within 48 hours of pour. Hold saw cuts 1/2" from edge of concrete.
- E. Score Joints: Form in the fresh concrete using a jointer to cut the groove so that a smooth uniform impression is obtained to 1" depth unless shown otherwise. All joints shall be struck before and after brooming. Tool concrete both sides of joint.
- F. Expansion Joints and Edging: Provided at the location and intervals as shown on the drawings, and at all locations where concrete paving abuts buildings, curbs or other structures, and not greater than 20 feet on center. Approved joint material shall be placed with top edge below the paved surface and shall be securely held in place to prevent movement. Joint and other edges shall be formed in the fresh concrete using an edging tool to provide a smooth uniform impression. All edges shall be struck before and after brooming.

3.7 FINISHING

- A. Mow bands, paving and other exposed work.
 - 1. Surface Finishes
 - (a) Float Finish (typical preliminary finishing for slabs to receive other finishes): The surface of the slab shall be screeded and all surface water and laitance removed. Floating shall be started as soon as the screeded surface has stiffened sufficiently. Floating shall be performed by hand using a wood float and shall be the minimum necessary to produce a relatively smooth, level, even-textured surface.

- (b) Medium Broom Finish: After the slab has been float finished as described above, the surface shall be uniformly directional textured by coarse stable broom to match accepted mock up to be a non-slip finish.
- (c) Sandblast Finish: Perform in as continuous an operation as possible, utilizing the same work crew to maintain continuity of finish to match accepted mock up. Use abrasive grit of the proper type and gradation to expose the aggregate and surrounding matrix surfaces to match mock up panel, as follows:
 - 1) Medium Cut: Approximately 1/8" to 3/16" depth.
 - 2) Heavy cut: Approximately 1/2" to 3/4" depth.
 - 3) Blast corners and edge of patterns carefully, using backup boards in order to maintain a uniform corner of edge line.
 - 4) Use same nozzle, nozzle pressure and blasting technique as used for mock up panel.
 - 5) Maintain control of abrasive grit and concrete dust in each area of blasting. Clean up and remove all expended abrasive grit, concrete dust and debris at the end of each day of blasting operations.

3.8 DEFECTIVE CONCRETE

- A. If any concrete work is not formed as indicated, is under strength concrete, if concrete is out of line, level or plumb, or showing objectionable cracks, honeycomb, rock pockets, voids, spelling or exposed reinforcing, it shall be removed, repaired or replaced as directed by the Landscape Architect.

3.9 CURING

- A. Cure exposed concrete in accordance with CalTrans Standard Specifications Section 90.
- B. Only water or curing compounds that impart no permanent color or gloss shall be used for curing concrete.

3.10 CONCRETE SEALING

- A. Seal all exposed surfaces according to manufacturer's specifications.

3.11 WATERPROOFING

- A. Where soil is backfilled against seat walls install waterproofing per manufacturer's specifications. Hold 2" below finish grade.
- B. During construction, wash off work as quickly as possible when stains or splotches are unavoidable.

3.12 TRUNCATED DOMES

- A. Detectable warning surface shall be recessed and cast in concrete.

3.13 CLEANUP: Per Division 1 requirements.

- A. Upon completion, clean exposed surfaces carefully. Brushing and cleaning solution, if used, must be preceded and followed with a through rinsing of clear water. No sandblasting will be allowed to clean surfaces.
- B. Remove from premises; equipment, debris and surplus material needed for, or resulting from, this work. Remove all concrete waste from planting areas and legally dispose of it.
- C. All work shall be left in a condition satisfactory to the Landscape Architect.

END OF SECTION 03 000

SECTION 32 1723

PAVEMENT MARKING

PART 1 - GENERAL

1.1 SECTION INCLUDES

- A. Provide pavement striping and symbols complete.
- B. Related work specified elsewhere includes:
 - 1. Section 32 1313 Concrete Paving
 - 2. Section 32 1216, Asphalt Concrete Paving

1.2 QUALITY ASSURANCE

- A. Reference Standards
 - 1. State of California "CALTRANS Standard Specifications," Sections 84 and 85.
 - 2. State of California, Title 24, Accessibility Standards and 'California Accessibility Reference Manual, November 1994.
 - 3. Manufacturer's specifications and recommendations.
 - 4. Perform all work in accordance with all applicable laws, codes and regulations required by the City of Brentwood.

1.3 SUBMITTALS: Per Division 1 requirements.

- A. Data on paint with color samples.

PART 2 - PRODUCTS

2.1 PAINTING

- A. Paints shall conform to CALTRANS Standard Specifications 84-3.02.
- B. Utilize paint compatible with the surfacing material.

PART 3 - EXECUTION

3.1 PREPARATION

- A. Pavements shall be fully cured and clean.
- B. Lay out markings accurately and obtain approval before installation. Striping line width on pavement for play courts shall be 2" minimum wide and white except where noted on drawings as yellow.
- C. Pavement markings shall be applied only on dry surfaces during periods of favorable weather. Temperature shall be above 35 degrees F. and rising, humidity less than 80 percent and falling, and no precipitation predicted for 24 hours.

3.2 INSTALLATION

- A. Install pavement markings in accordance with reference standards.
 - 1. Paints, where indicated, shall be applied in accordance with CALTRANS Standard Specifications 84-3.03 through 84.3.05. Edges shall be clean and well defined.
 - 2. Apply two coats of paint to the satisfaction of the Project Inspector and Architect.

3.3 CLEANING

Per Division 1 requirements.

- A. Remove from premises; equipment, debris and surplus material needed for, or resulting from, this work. Remove excess adhesives or paint over-spray or tracking onto unmarked areas.
- B. All work shall be left in a condition satisfactory to the Project Inspector and Architect.

END OF SECTION 32 1723

SECTION 32 3113

CHAIN LINK FENCES AND GATES

PART 1 GENERAL

1.01 SUMMARY

A. Scope of Work

The Contractor shall furnish all labor, materials, equipment, and incidentals necessary to furnish and construct the fencing specified herein, and shown on the Drawings, complete.

B. The work shall include, but shall not be limited to:

1. Fence and Gate Fabric, Rails, Hardware, Framework, and Posts
2. Excavation for Post Bases
3. Concrete Anchorage for Posts

C. Related Work

1. 03 3000 Cast-In-Place Concrete
2. 32 3119 Ornamental Steel Fences
3. 32 3121 Double Heavy Duty Swing Gate

1.02 COORDINATION

- ###### A. Coordinate work fully with all other trades involved. Coordinate with items of other trades to be furnished and set in place. Such portions of their work as is all or in part embedded, built-in, attached to, or supported by the work shall be executed by them in ample time that progress of the work is not delayed. Contractor shall be responsible for the proper installation of all items related to this section.

1.03 REFERENCE

- ###### A. Perform work in accordance with all applicable laws, codes and regulations, as required by the Architect.
- ###### B. Reference to "Standard Specifications" shall mean the current Standard Specifications of the State of California, Business and Transportation Agency, Department of Transportation, CALTRANS.

1.04 SUBMITTALS

The following information shall be submitted for approval by the Architect.

A. Erector Qualifications:

- ###### B. List of seven (7) similar fence installations in Northern California. Include job location and name and phone number of project administrator.

- ###### C. Product Data: Submit Manufacturer's descriptive literature and/or standard catalog "cut-sheets" of all materials, coatings, fittings and equipment proposed to be furnished and installed under this portion of the work. Include Manufacturer's name and catalog number for each item where applicable. Clearly annotate (star or asterisk - in black ink) which portions of "cut-sheets" are applicable if more than one product is shown.

1. Framework (rail, post and gate)
 2. Wire mesh
 3. Privacy Slats
 4. Support arm
 5. Hinges and latches
 6. Gate hardware
- D. Shop Drawings: Submit complete Shop Drawings for all different types and sizes of gates and fencing systems.
1. Shop Drawings shall include, but not be limited to:
 - a. All information regarding clearances, connections, components and any miscellaneous related appurtenances (such as locking mechanisms, wiring etc.).
 - b. Concrete footing and reinforcement information.
- E. Installation instructions and/or drawings: Submit as applicable.
- 1.05 SEQUENCE AND SCHEDULING
- A. Contractor shall coordinate construction timing of all fencing and related work with installation of concrete work and all other work.
- 1.06 CLEAN UP
- A. Keep job site free of debris and rubbish as well as excess materials, tools and equipment connected with work specified herein. Clean up periodically during construction and at completion of work specified herein; lawfully dispose of all such material off District's premises.

PART 2 PRODUCTS

- 2.01 MATERIALS
- A. General Note: It is intended that all fencing, by area, receive the same finish coating wherever possible. Nuts, bolts, applicable moving portions of hinges etc, shall be finished to match.
- B. Fabric
1. Selvage: Knuckled finish top and bottom.
 2. Steel Fabric: Comply with Chain Link Fence Manufacturers Institute (CLFMI) Product Manual. Furnish one-piece fabric widths for fencing up to sixteen feet (16') feet high. Wire sizes includes zinc coating.
 3. Size: One inch (1") or Two inch (2") mesh, 9-gauge (0.148 inch diameter) as noted on the Drawings.
 4. Galvanized Wire: Zinc coated wire-ASTM A 392, Class 1, with not less than 1.2 oz. zinc per sq. ft.
 5. Thermally fused and bonded PVC (vinyl coated) Finish: ASTM F 668 Class 2b, 7mil (0.18 mm) thickness thermally fused over zinc coated wire where noted on the Drawings.
- C. Framing
1. Strength requirements for posts and rails shall conform to ASTM F 669.
 2. Pipe shall be straight, true to section, material, and sizes specified, and shall conform to the following weights per foot:

| <u>NPS in Inches</u> | <u>Outside Diameter (OD in inches)</u> | <u>Type 1 Steel</u> | <u>Type 2 Steel</u> |
|--------------------------|--|-------------------------|-------------------------|
| 1 | 1.315 | 1.68 | 1.35 |
| 1.25 | 1.660 (1-5/8") | 2.27 | 1.84 |
| 1.5 | 1.900 (2") | 2.72 | 2.28 |
| 2 | 2.375 (2-1/2") | 3.65 | 3.12 |
| 2.5 | 2.875 (3") | 5.79 | 4.64 |
| 3 | 3.500 | 7.58 | 5.71 |
| 3.5 | 4.000 | 9.11 | 6.56 |
| 4 | 4.500 | 10.79 | --- |
| 6 | 6.625 | 18.97 | --- |
| 8 | 8.625 | 28.55 | --- |

D. Steel Framework

1. Posts, Rails, Braces, and Gate Frames:
 - a. Type I Steel Pipe: Hot-dipped galvanized steel pipe conforming to ASTM F 1083, plain ends, standard weight (Schedule 40) with not less than 1.8 oz. zinc per sq. ft. of surface area.
 - b. Type II pipe: not applicable.
2. Top, Bottom and Horizontal Intermediate Rails:
 - a. Top, bottom and horizontal intermediate rails (as applicable) shall be as shown on the Drawings.
3. Gate Frames: Furnish frames (single or double gate), for nominal gate widths as shown on the Drawings.

E. Fittings and Accessories

1. Material: Comply with ASTM F 626. Mill-finished aluminum or galvanized iron or steel, in accordance with Manufacturer's standards.
 - a. Zinc Coating: Unless specified otherwise, steel fence fittings and accessories shall be galvanized in accordance with ASTM A 153, with zinc weights per Table 1 of ASTM A153.
2. Tension Wire: 7 gauge (0.177 inch diameter) coil spring steel with finish to match fabric.
3. Tie Wires: 9 gauge (0.148 inch diameter) steel with finish to match fabric.
4. Post and Line Caps: Provide weather tight closure cap for each post. Provide line post caps with loop to receive wire or top rail with finish to match fabric.
5. Tension Bars: Hot dipped galvanized steel with minimum length two inches (2") less than full height of fabric, minimum cross-section of 3/16 inch by 3/4 inch and minimum of 1.2 oz. zinc coating per sq. ft. of surface area.
6. Tension Clips: Minimum 3/4 inch wide 12 gauge (0.105 inch) thick with finish to match fabric.
7. Truss Rods: Hot dipped galvanized steel rods with minimum diameter of 5/16 inches (5/16") (7.9 mm).
8. Hinges: Master Halco heavy duty for maintenance gates, or acceptable equal. All other gates shall have hydraulic hinges, self-closing and adjustable speed.
9. Handle with Key Lock: Shall be as specified on the Drawings.
10. Push bar/Panic exit hardware: shall be as specified on the Drawings.
11. Lockable Galvanized Steel Butterfly Latch: Shall be as specified on the Drawings.
12. Drop Rod Assembly: Shall be as specified on the Drawings.

13. Concrete: Concrete for footings shall conform to the requirements of ASTM C94, normal Portland cement, 3000 psi at twenty-eight (28) days, four inch (4") slump. Refer to Section 03 3000 - Cast-In-Place Concrete.
14. Privacy Slats shall be bottom locking, double wall slats where noted on the Drawings.

PART 3 EXECUTION

3.01 PREPARATION

- A. Prior to excavation, layout all fencing locations for review and acceptance by Architect.

3.02 INSTALLATION

- A. Chain link fencing shall be constructed as shown on the Drawings and a height therein specified. The line of the fence shall be cleared of all obstructions and surface irregularities and the bottom of the fence shall be to uniform grade.
- B. Unless otherwise set forth in the Drawings, all fence shall be constructed with a top rail, and a bottom rail.
- C. The posts shall be spaced as specified on the Drawings. Terminal posts and gate posts shall be set as specified on Drawings. Line posts shall be set as specified on Drawings.
- D. Post shall be set as specified on the Drawings.
- E. Concrete bases for terminal, line, and gate posts shall be allowed to cure for not less than seven (7) days before wire fabric is placed.
- F. Fabric shall be fastened to line posts with fabric bands spaced approximately fourteen inches (14") apart and to top rail and bottom tension wire with tie wires spaced approximately twenty-four inches (24") apart.
- G. Stretcher bar and truss bands shall be spread and slipped on end, corner, pull, brace, and gate posts before installation of top rails. Extension joints shall be provided from rails at intervals of one hundred feet (100'). Bottom tension wire shall be seven (7) gauge galvanized coil spring steel.
- H. Pass top rail through line post tops to form continuous bracing. Install seven inch (7") long couplings midspan at pipe ends.
- I. The placing of the rails, braces, and the wire fabric shall be accomplished in such a manner that the finished fence shall be taut, true, and of precise workmanship throughout. The fabric shall be stretched so that no slack sections remain at any point. The fabric shall be securely tied to posts and rails in a manner so that the fabric will remain tight and immovable.
- J. Position bottom of fabric three inches (3") above finished grade, or as shown on the Drawings, with tension wire stretched taut between posts.
- K. Cut and peen bolts so that bolts protrude one quarter inch (1/4") maximum beyond nuts and there are no sharp edges.

END OF SECTION

SECTION 32 3119

ORNAMENTAL STEEL FENCES AND GATES

PART 1 GENERAL

1.01 SUMMARY

A. Scope of Work

The Contractor shall furnish all labor, materials, and appurtenances necessary for installation of the industrial ornamental steel fence system defined herein.

B. Related Work:

1. 03 3000 Cast-In-Place Concrete
2. 32 3113 Chain Link Fences and Gates

1.02 COORDINATION

- ###### A.
- Coordinate work fully with all other trades involved. Coordinate with items of other trades to be furnished and set in place. Such portions of their work as is all or in part embedded, built-in, attached to, or supported by the work shall be executed by them in ample time that progress of the work is not delayed. Contractor shall be responsible for the proper installation of all items related to this section.

1.03 SYSTEM DESCRIPTION

- ###### A.
- The Manufacturer shall supply a total industrial ornamental steel fence system of the Ameristar® Aegis II® Majestic design. The system shall include all components (i.e., pickets, rails, posts, gates and hardware) required.

1.04 QUALITY ASSURANCE

- ###### A.
- The Contractor shall provide laborers and supervisors who are thoroughly familiar with the type of construction involved and materials and techniques specified.

1.05 REFERENCES

- A. ASTM A653/A653M - Standard Specification for Steel Sheet, Zinc-Coated (Galvanized) or Zinc-Iron Alloy Coated (Galvannealed) by the Hot-Dip Process.
- B. ASTM B117 - Practice for Operating Salt-Spray (Fog) Apparatus.
- C. ASTM D523 - Test Method for Specular Gloss.
- D. ASTM D714 - Test Method for Evaluating Degree of Blistering in Paint.
- E. ASTM D822 - Practice for Conducting Tests on Paint and Related Coatings and Materials using Filtered Open-Flame Carbon-Arc Light and Water Exposure Apparatus.
- F. ASTM D1654 - Test Method for Evaluation of Painted or Coated Specimens Subjected to Corrosive Environments.
- G. ASTM D2244 - Test Method for Calculation of Color Differences from Instrumentally Measured Color Coordinates.

- H. ASTM D2794 - Test Method for Resistance of Organic Coatings to the Effects of Rapid Deformation (Impact).
- I. ASTM D3359 - Test Method for Measuring Adhesion by Tape Test.
- J. ASTM F2408 - Ornamental Fences Employing Galvanized Steel Tubular Pickets.

1.06 SUBMITTAL

- A. Product Data: For each type of product indicated.
- B. Shop Drawings: For gates. Include plans, elevations, sections, details, and attachments to other work.
- C. Samples: For each fence material and for each color specified
 - 1. Provide Samples 12 inches in length for linear materials.
 - 2. Provide Samples 12 inches in length for sheet materials.
- D. Welding Certificates
- E. Product Test Reports: Based on evaluation of comprehensive tests performed by a qualified testing agency, for decorative metallic-coated steel tubular picket gates including finish, indicating compliance with referenced standard and other specified requirements.

1.07 PRODUCT HANDLING AND STORAGE

- A. Upon receipt at the job site, all materials shall be checked to ensure that no damages occurred during shipping or handling. Materials shall be stored in such a manner to ensure proper ventilation and drainage, and to protect against damage, weather, vandalism and theft.

1.08 PRODUCT WARRANTY

- A. All structural fence components (i.e. rails, pickets, and posts) shall be warranted within specified limitations, by the Manufacturer for a period of 10 years from date of original purchase. Warranty shall cover any defects in material finish, including cracking, peeling, chipping, blistering or corroding.
- B. Reimbursement for labor necessary to restore or replace components that have been found to be defective under the terms of manufactures warranty shall be guaranteed for five (5) years from date of original purchase.

1.09 QUALITY ASSURANCE

- A. Installer Qualifications: Fabricator of products.
- B. Welding Qualifications: Qualify procedures and personnel according to AWS D1.1/D1.1M, "Structural Welding Code - Steel."
- C. Mockups: Build mockups to verify selections made under sample submittals and to demonstrate aesthetic effects and set quality standards for fabrication and installation.
- D. Include ten (10) foot length of fence complying with requirements.
- E. Approved mockups may become part of the completed Work if undisturbed at time of substantial Completion.
- F. Preinstallation Conference: Conduct conference at Project site.
- G. The Contractor shall provide laborers and supervisors who are thoroughly familiar with the type of constructions involved and materials and techniques specified.

PART 2 MATERIALS

2.01 MANUFACTURER

- A. The fence system shall conform to Ameristar Aegis II, Majestic 3-Rails with 3-3/4" picket gap style manufactured by Ameristar Fence Products, Inc. in Tulsa, Oklahoma, or approved equal.

2.02 MATERIAL

- A. Steel material for fence framework (i.e. tubular pickets, rails and posts), shall be galvanized prior to forming in accordance with the requirements of ASTM A653/A653M, with minimum yield strength of 45,000 psi (310 MPa). The steel shall be hot-dip galvanized to meet the requirements of ASTM A653/A653M with a minimum zinc coating weight of 0.90 oz/ft² (276 g/m²), Coating Designation G-90.
- B. Material for pickets shall be 1" square x 14 Ga. tubing. The cross-sectional shape of the rails shall conform to the manufacturer's ForeRunner™ double wall design with outside cross-section dimensions of 1.75" square and a minimum thickness of 14 Ga. Picket holes in the ForeRunner rail shall be spaced 4.715" o.c., unless otherwise noted. Picket retaining rods shall be 0.125" diameter galvanized steel. High quality PVC grommets shall be supplied to seal all picket-to-rail intersections. Fence posts and gateposts shall meet the minimum size requirements of Table 1. See Structural Drawings for additional information.

2.03 FABRICATION

- A. Pickets, rails and posts shall be precut to specified lengths. ForeRunner rails shall be prepunched to accept pickets. Pickets shall be predrilled to accept retaining rods.
- B. Grommets shall be inserted into the prepunched holes in the rails and pickets shall be inserted through the grommets so that predrilled picket holes align with the internal upper raceway of the ForeRunner rails (Note: This can best be accomplished by making an alignment jig). Retaining rods shall be inserted into each ForeRunner rail so that they pass through the predrilled holes in each picket.
- C. The manufactured galvanized framework shall be subjected to the PermaCoat® thermal stratification coating process (high-temperature, in-line, multi-stage, multi-layer) including, as a minimum, a six-stage pretreatment/wash, an electrostatic spray application of an epoxy base, and a separate electrostatic spray application of a polyester finish. The base coat shall be a thermosetting epoxy powder coating (gray in color) with a minimum thickness of 2 mils (0.0508mm). The topcoat shall be a "no-mar" TGIC polyester powder coat finish with a minimum thickness of 2 mils (0.0508mm). The color shall be Black. The stratification-coated framework shall be capable of meeting the performance requirements for each quality characteristic shown in Table 2.
- D. Completed sections (i.e., panels) shall be capable of supporting a 600 lb. load applied at midspan without permanent deformation. Panels shall be biasable to a 25% change in grade.

PART 3 EXECUTION

3.01 PREPARATION

- A. All new installation shall be laid out by the Contractor in accordance with the Drawings.

3.02 FENCE INSTALLATION

- A. Fence post shall be spaced according to Table 3, plus or minus 1/2" and as shown in the Drawings. For installations that must be raked to follow sloping grades, the post spacing dimension must be measured along the grade. Fence panels shall be attached to posts with brackets supplied by the Manufacturer. See Structural Drawings for post and footing information.

3.03 FENCE INSTALLATION MAINTENANCE

- A. When cutting/drilling rails or posts adhere to the following steps to seal the exposed steel surfaces; 1) Remove all metal shavings from cut area. 2) Apply zinc-rich primer to thoroughly cover cut edge and/or drilled hole; let dry. 3) Apply 2 coats of custom finish paint matching fence color. Failure to seal exposed surfaces per steps 1-3 above will negate warranty. Fence Manufacturer's spray cans or paint pens shall be used to prime and finish exposed surfaces; it is recommended that paint pens be used to prevent overspray. Use of non-compliant parts or components will negate the Manufacturers' warranty.

| Table 1 - Minimum Sizes for Aegis II Posts | | | | |
|---|--------------------------------------|---|--|-----------------|
| <u>Fence Posts</u> | <u>Panel Height</u> | | | |
| 2-1/2" x 12 Ga. | Up to & Including 6' Height | | | |
| 3" x 12 Ga. | Over 6' Up to & Including 10' Height | | | |
| 4" x 11 Ga. | Over 10' Height | | | |
| | | | | |
| <u>Gate Leaf</u> | <u>Gate Height</u> | | | |
| | <u>Up to & Including 6'</u> | <u>Over 6' Up to & Including 8'</u> | <u>Over 8' Up to & Including 10'</u> | <u>Over 12'</u> |
| Up to 4' | 3" x 12Ga. | 3" x 12 Ga. | 4" x 11 Ga. | 4" x 11 Ga. |
| 4'1" to 6' | 3" x 12Ga. | 3" x 12 Ga. | 4" x 11 Ga. | 4" x 11 Ga. |
| 6'1" to 8' | 4" x 11 Ga. | 6" x 3/16" | 6" x 3/16" | 6" x 3/16" |
| 8'1" to 10' | 4" x 11 Ga. | 6" x 3/16" | 6" x 3/16" | 6" x 3/16" |
| 10'1" to 12' | 6" x 3/16" | 6" x 3/16" | 6" x 3/16" | 8" x 1/4" |
| 12'1" to 16' | 6" x 3/16" | 6" x 3/16" | 8" x 1/4" | 8" x 1/4" |

| <u>Quality Characteristics</u> | <u>ASTM Test Method</u> | <u>Performance Requirements</u> |
|--------------------------------|-------------------------------|---|
| Adhesion | D3359 – Method B | Adhesion (Retention of Coating) over 90% of test area (Tape and knife test). |
| Corrosion Resistance | B117, D714 & D1654 | Corrosion Resistance over 3,500 hours (Scribed per D1654; failure mode is accumulation of 1/8" coating loss from scribe or medium #8 blisters). |
| Impact Resistance | D2794 | Impact Resistance over 60 inch lb. (Forward impact using 0.625" ball). |
| Weathering Resistance | D822 D2244, D523 (60° Method) | Weathering Resistance over 1,000 hours (Failure mode is 60% loss of gloss or color variance of more than 3 delta-E color units). |

| Span | For INVINCIBLE® 8' Nominal (91.25" Rail) | | For CLASSIC, GENESIS, & MAJESTIC 8' Nominal (92.625" Rail) | | | | | |
|---|---|-------|---|------------------------------|-------------------------------|---------|----------------------------|--------|
| Post Size | 2-1/2" | 3" | 2-1/2" | 3" | 2-1/2" | 3" | 2-1/2" | 3" |
| Bracket Type | Industrial Flat Mount (BB301) | | Industrial Universal (BB302) | Industrial Universal (BB303) | Industrial Flat Mount (BB301) | | Industrial Swivel (BB304)* | |
| Post Settings ± 1/2" O.C. | 94-1/2" | 95" | 96" | 96.5" | 96" | 96-1/2" | *97-1/2" | *98" |
| Span | For INVINCIBLE® 6' Nominal (67.75" Rail) | | For CLASSIC, GENESIS, & MAJESTIC 6' Nominal (71.375" Rail) | | | | | |
| Post Size | 2-1/2" | 3" | 2-1/2" | 3" | 2-1/2" | 3" | 2-1/2" | 3" |
| Bracket Type | Industrial Flat Mount (BB301) | | Industrial Universal (BB302) | Industrial Universal (BB303) | Industrial Flat Mount (BB301) | | Industrial Swivel (BB304)* | |
| Post Settings ± 1/2" O.C. | 75" | 75.5" | 71.5" | 72" | 71.5" | 72" | *73" | *73.5" |
| *Note: When using BB304 swivel brackets on either or both ends of a panel installation, care must be taken to ensure the spacing between post and adjoining pickets meets applicable codes. This will require trimming one or both ends of the panel. | | | | | | | | |

END OF SECTION

SECTION 32 3121

DOUBLE HEAVY DUTY SWING GATE

PART 1 GENERAL

1.01 SUMMARY

- A. The work in this section shall include furnishing all labor, materials, equipment and appliances necessary to complete all Heavy Duty Swing Gate Systems required for this project in strict accordance with this specification section and the Drawings.
- B. Related Work:
- C. 03 3000 Cast-In-Place Concrete
 - 1. 32 3113 Chain Link Fences and Gates
 - 2. 32 3119 Ornamental Steel Fences and Gates

1.02 REFERENCES

- A. Underwriters Laboratory Gate Operator Requirements (UL 325).
- B. ASTM F 2200 Standard Specification for Automated Vehicular Gate Construction.
- C. American Welding Society AWS D1.2 Structural Welding Code.
- D. ASTM F 900 Standard Specification for Industrial and Commercial Swing Gates.

1.03 SUBMITTALS

- A. Product Data
 - 1. Provide Manufacturer's catalog cuts with printed specifications and installation instructions.
 - 2. Deliver two copies of operation and maintenance data covering the installed products. Manual to include parts list showing Manufacturer's names and part numbers for the gate operator.
- B. Shop Drawings
 - 1. Supply shop drawings showing the relationship of operating systems with gate components, including details of all major components.
 - 2. Include complete details of gate construction, gate height and post spacing dimensions.
- C. Certifications
 - 1. Gate Manufacturer shall provide independent certification as to the use of a documented Welding Procedure Specification and Procedure Qualification Record to insure conformance to the AWS D1.2 welding code. Upon request, Individual Certificates of Welder Qualification documenting successful completion of the requirements of the AWS D1.2 code shall also be provided.

PART 2 PRODUCTS

2.01 SWING GATE SYSTEM MANUFACTURER

- A. The double swing gate system shall be manufactured by Tymetal Corp., 678 Wilbur Avenue, Greenwich, NY 12834 - (800) 328-4283, or approved equal.

- B. Approved Substitution: All other systems must be submitted to the District in accordance with substitution requirements as set forth in the general provisions of the specification manual for approval prior to the bid date. Products submitted after the bid date will not be approved.

2.02 GATE CONSTRUCTION DETAILS

A. Gate Frame

1. The gate frame shall be fabricated from 6063-T6 aluminum alloy extrusions. The top member shall be a 3" x 5" (76mm x 127mm) aluminum structural channel/tube extrusion weighing not less than 3.0 lb/lf (4.4kg/m) for Internal Picket designs or 2.6 lb/lf (3.8kg/m) for External Picket designs. The bottom member shall be a 2" x 5" (51mm x 127mm) aluminum structural tube weighing not less than 2.0 lb/lf (2.9kg/m).
2. Vertical Members
 - a. Chain Link: The vertical members at the ends of the opening portion of the frame shall be 2" x 2" (51mm x 51mm) in the cross section weighing not less than 1.1 lb/lf (1.6kg/m). The major vertical members separating each bay shall be 1" x 2" (25mm x 51mm) in cross section weighing not less than .82 lb/lf (1.2kg/m). The spacing for the major vertical members shall be less than 50% gate frame height.
3. All welds on the gate frame shall conform to Welding Procedure Specification and Procedure Qualification Record to insure conformance to the AWS D1.2 Structural Welding Code. All individual welders shall be certified to AWS D1.2 welding code. See 1.03 C.1.
4. Each gate leaf shall be provided with a minimum of two pivoting hinges to allow proper operation, and shall be connected to the gate side of the hinge by means of two through-bolts.

B. Diagonal Bracing

1. Diagonal "X" bracing of 3/16" or 1/4" diameter stainless or galvanized steel cable shall be installed throughout the gate to provide additional vertical adjustment.

C. Posts

1. Gate hanger posts shall be sized in accordance with gate dimensions as specified by the Manufacturer. Height of the post and depth of footing shall be as specified by the Structural Engineer.

D. Lock

1. Single gates shall have a latch assembly to provide a means for locking with a padlock.
2. Double gates shall have a drop-bar mechanism extending into the ground, and a center locking kit to provide a means for locking with a padlock.

E. The gate shall be completed by installation of approved filler as specified.

1. Chain Link: 2" x 2" x 9 gauge aluminized steel chain link fabric shall extend the entire length of the gate panel. Fabric shall be attached at each end of the gate frame by standard fence industry tension bars and tied at each 2" x 2" (51mm x 51mm) vertical member with standard fence industry ties. ASTM F 2200 requires attachment method that leaves no leading or bottom edge protrusions (cannot exceed 0.5 inch).

F. Finish

1. Gate shall be mill finish aluminum or color coated with polyester powder as specified. If powder coated, the gate and all accessories shall be pretreated chemically by sand blasting or other acceptable method to ensure proper coating adherence. Gate posts shall be galvanized or coated to match the gate.

PART 3 EXECUTION

3.01 INSTALLATION

- A. Excavate, place concrete and install specified sized posts as detailed, and in accordance with approved shop drawings. Install hinges on gate frame and gateposts. Make final adjustments to maintain alignment of gate leaves. Install equipment of this section in strict accordance with the Manufacturer's printed instructions unless otherwise shown on the Drawings.
- B. The gate and installation shall conform with ASTM F 900 standards for aluminum swing gates.
- C. If the gate system is automated, the gate and installation shall comply with UL 325 Gate Operator Requirements and ASTM F 2200, Standard Specifications for Automated Vehicular Gate Construction.

3.02 SYSTEM VALIDATION:

- A. The complete system shall be adjusted to assure it is performing properly.
- B. The system shall be operated for a sufficient period of time to determine that the system is in proper working order.
- C. For operated gate systems - test and explain safety features:
 - 1. Each system feature and device is a separate component of the gate system.
 - 2. Read and follow all instructions for each component.
 - 3. Ensure that all instructions for mechanical components, safety devices and the gate operator are available for everyone who will be using the gate system.
 - 4. The warning signs shipped with the gate operator must be installed in prominent position on both sides of the gate.
 - 5. Ensure the District is clear with regard to the safety points concerning the basic operational guidelines of the safety features of the gate operator system. These safety points are listed in the gate operator manual and must be read prior to system use.

END OF SECTION

SECTION 32 8000

IRRIGATION SYSTEM

PART 1 GENERAL

1.01 DESCRIPTION

- A. The General Conditions and all other Contract Documents for this project are complementary and applicable to this Section of the Specifications.
- B. Work Included: Order and furnish all labor, materials, supplies, tools and transportation and perform all operations for a complete installation of the recycled water connection and automatic irrigation system as shown on the Drawings. Items listed hereinafter are included as an aid to estimating quantities and are not necessarily a complete list of work items.
 - 1. Trenching, stockpiling excavation materials, and refilling trenches.
 - 2. Furnishing materials and installation for complete system including piping, valves, fittings, sprinkler heads, bubblers, final adjustment of sprinkler heads, and bubbler heads to ensure complete coverage of water to plants and trees.
 - 3. Low voltage 2-wire control wiring, decoders, and surge protection from existing irrigation controller to remote control valves.
 - 4. Replacement of unsatisfactory materials.
 - 5. Clean-up, inspection and approval.
 - 6. All work of every description mentioned in the Specification and/or addenda thereto, and all other labor and materials reasonably incidental to the satisfactory completion of the work, including clean-up of the site, as directed by the District.
 - 7. Tests.
 - 8. Record Drawings.
- C. Related Work Described Elsewhere:
 - 1. 26 0000: Electrical Specification
 - 2. 32 9000: Landscape Planting

1.02 GENERAL REQUIREMENTS

- A. Purpose: It is the intention of these Specifications to accomplish the work of installing an irrigation system which shall operate in an efficient manner, provide 100% uniform coverage, and be water conserving. The Drawings indicate the general arrangement of piping and equipment, and do not necessarily indicate all offsets, fittings and accessories that may be required. Furnish incidental materials and labor not specifically called for but required to complete work as intended.
- B. OSHA Compliance: All articles and services covered by this Specification shall meet or exceed the safety standards established under the Federal Occupational Safety and Health Act of 1970, together with all amendments in effect as of the date of this Specification.
- C. Codes and Standards: Comply with all applicable codes and standards.
 - 1. Perform work in accordance with the District's (LUHSD) standards.
 - 2. Work and materials shall be in full accordance with the latest rules and regulations of the California Electric Code, the Uniform Plumbing Code, published by the Western Plumbing Officials Association and other applicable State or local laws or regulations. Nothing in these Drawings or Specifications shall be construed to permit work not conforming to these codes.
 - 3. When the Specifications call for materials or construction of a better quality or larger size than required by the above-mentioned rules and regulations, the provision of the

Specifications shall take precedence over the requirements of the said rules and regulations.

4. Furnish, without any additional cost to the District, any additional material and labor required to comply with these rules and regulations. Provide the work even if it is not mentioned in this section, or shown on the Drawings.
5. Erect and maintain barricades, guards, warning signs and lights as required by the District or required by OSHA regulations for the protection of the public or work crew.
6. Damage by Leaks: The Contractor shall be responsible for damages to any property or work caused by leaks in the piping systems being installed. Repair, at no additional expense to the District, all damages so caused. All repair work shall be done as directed, and in a manner that is satisfactory to the District.
7. Protection: The Contractor shall be responsible for any damage to this work, which occurs before final acceptance. Securely cover all openings into the systems and protect all apparatus, equipment and appliances, both before and after being set in place, to prevent obstructions in the pipes and breakage, misuse or disfigurement of the apparatus, equipment of appliance.

1.03 QUALITY ASSURANCE

- A. Provide evidence to the District that skilled and an experienced supervisor and work crew will be employed on the job from beginning to end.
- B. Provide evidence to the District that the Contractor is skilled and experienced in the construction of a commercial-grade irrigation system. Contractor shall provide with the bid documents a list of at least five irrigation projects constructed in the last five years by the Contractor that have used the listed equipment.

1.04 INSTRUCTION

- A. After the system has been installed and approved, instruct the District's personnel in the complete operation and maintenance of the irrigation system.

1.05 SUBMITTALS

- A. Equipment List and Drawings: Within 14 days after date of Notice to Proceed, submit to the District for approval, a list of the proposed equipment and material to be furnished and installed. The list shall be complete as to name of manufacturer, size and catalog number of unit, and be supplemented by such other data as may be required, including detailed scale Drawings, plumbing and wiring diagrams. Submit materials list using the following format:

| <u>Item</u> | <u>Description</u> | <u>Manufacturer</u> | <u>Model No.</u> |
|-------------|----------------------|---------------------|------------------|
| 1 | Pressure Supply Line | Lasco | Sch. 40 |
| 2 | Lawn Head | Rain Bird | 2400 |

- B. Record Drawings:
 1. Record accurately on one set of blue or black line prints, changes in the work constituting departures from the original contract Drawings, including changes in pressure and non-pressure line locations, and a complete schematic diagram.
 2. Record the changes and dimensions in a legible manner and to the satisfaction of the District. Prior to final inspection of work, and prior to transferring the information to mylars, submit record prints to the District for approval.
 3. Dimension from two permanent points of reference (buildings, monuments, sidewalks, curbs, pavements, etc.). Record data to be shown on record prints, day-to-day, as the project is being installed.
 4. Show locations and depths of the following items:

- a. Point of connection(s).
 - b. Routing of irrigation main line pipe. Provide dimensions a minimum of 100 feet along main line route.
 - c. Gate valves.
 - d. Remote control valves or valve groups.
 - e. Routing of control wires.
 - f. Routing of conduit.
 - g. Sleeves.
 - h. Related equipment including sprinkler heads (as may be directed by the District).
5. Maintain record prints on-site at all times.
 6. Upon completion of work, transfer all as-built information and dimensions to reproducible sepia mylars. Correct and record the changes and dimensions in a legible manner and to the satisfaction of the District.

PART 2 PRODUCTS

2.01 PIPE: MAIN AND LATERAL LINE

- A. Pipe manufacturer: PW Pipe, JM Eagle Pipe, or approved equal.
- B. Pipe Material: Polyvinylchloride (PVC) plastic in conformance with ASTM D1784 (cell class 12454-B).
- C. Schedule or Class:
 1. Main line pipe:
 - a. 2.5-inch and smaller: Schedule 40 PVC plastic pipe with solvent cemented joints.
 - b. Purple for use with recycled water.
 2. Lateral line pipe (non-pressure):
 - a. Schedule 40 PVC plastic pipe with Schedule 40 Type I, Grade I, PVC with solvent weld or threaded fittings as shown on the Drawings.
 - b. Purple for use with recycled water.
- D. Identification marking: Pipe shall be clearly marked at regular intervals indicating the manufacturer's name, nominal pipe size, schedule or class, pressure rating in PSI, date of extrusion, and recycled water use warnings.
- E. Sleeves: 1120-Schedule 40 or Class 200 PVC pipe, whichever has the thickest wall thickness, minimum of two times the diameter of pipe contained within.
- F. Connections between main lines and remote control valves: Schedule 80 PVC (threaded both ends) nipples and fittings as per the construction details.

2.02 PVC PIPE FITTINGS

- A. 2.5-inch and smaller PVC fitting manufacturer: Lasco, Dura, Spears, or approved equal.

2.03 GATE OR BALL VALVES

- A. Provide the valves as listed on the Drawings.
- B. Gate valves shall have a resilient wedge.
- C. Ball valves shall be the full port style.

2.04 REMOTE CONTROL VALVE

- A. Provide the solenoid remote control valves as listed on the Drawings.

- A. Provide the quick coupling valves as listed on the Drawings.

2.06 BOXES FOR CONTROL VALVES, QCV, AND GATE VALVE

- A. Remote control valves and pull boxes: Carson Model 1419, 12-inch x 17-inch x 12 inch-deep (top dimensions) valve box with bolt-down plastic lid or approved equal. Lid shall be marked: "Irrigation".
- B. Gate valve and quick coupling valve: Carson Model 910, 12-inch deep round plastic valve box with plastic lid. Lid shall be marked: "Irrigation".
- C. Use plastic box extensions made by the same manufacturer and of equal size to the valve box as required to allow access to the valve.
- D. The valve box and lid shall be a purple color, as manufactured by the vendor.

2.07 CONTROLLER

- A. The controller is existing from the LUHSD field improvements.

2.08 LOW VOLTAGE WIRE

- A. Wire type: Polyethylene double-jacketed or UF-B UL PVC double-jacketed two-conductor solid core designed for direct burial with insulation 3/16 inch (.060") thick, high density, sunlight resistant incased in an outer jacket of polyethylene or PVC conforming to ICEA S-GL-402 or NEMA WC5, having a minimum wall thickness of .045 inches. (#TW-CAB-14) All wire insulation shall be intact and free of nicks and cuts. (Two-wire Polyethylene "twisted" cable does NOT conform to these specifications.) Provide Rainmaster 2-wire cable.
- B. Notes:
 - 1. All wire insulation shall be intact and free of nicks and cuts.
 - 2. All wire connections need to be absolutely water tight.
 - 3. Wiring Sizes: Standard wire lengths for straight line installation i.e. wire distance to the furthest device without any loop: (Wire size chart is provided for reference only, #14Ga wire or larger is always recommended as specified above.)

| Wire size (gauge) | #14 | #12 |
|----------------------------------|--------|--------|
| Total loop wire length (ft.) | 10,000 | 14,800 |
| Distance to furthest valve (ft.) | 5,000 | 7,400 |

- C. Weatherproof splices: 3M model 3M-DBY, King model Dryconn #10999, Spears model #400 pre-filled seal packs or approved equal.

2.09 IRRIGATION HEADS

- A. Provide and install the spray, bubbler, and rotor heads as listed and detailed on the Drawings.
- B. Irrigation head body and risers: Provide and install bodies and risers as shown in the construction details using Schedule 80 PVC threaded nipples with Schedule 80 PVC elbows, District approved vendor pre-fabricated swing joints, or algae resistant flexible PVC tubing.

2.10 PULL BOXES

- A. Install pull boxes at the locations shown on the plans or at locations designated by the District at site of work. Contractor may, at no additional expense to the District, install additional pull boxes to facilitate work with good reason.

- B. Carson Model 1419, 12-inch x 17-inch x 12-inch deep valve box with bolt-down plastic lid or approved equal. Lid shall be marked: "Irrigation". Black color boxes are acceptable for electrical pull boxes.

2.11 PVC-CONDUIT

- A. Polyvinylchloride conduit: heavy-wall, Schedule 40, with factory made solvent cemented socket sweep elbows, couplings and fittings, as permitted by NEC.

2.12 RECYCLED WATER MARKING (VALVES)

- A. Manufacturer: T. Christy Enterprises part no. 3150 (no known equal).
- B. Material: Polyurethane behr desopan.
 - 1. 3 inch by 4 inch in size and hot stamped with 1-1/8 inch black letters on a yellow background, which states in English and Spanish "WARNING - RECYCLED WATER - DO NOT DRINK".
 - 2. Manufacturer provided punched hole.

2.13 VALVE IDENTIFICATION TAGS

- A. Manufacturer: T. Christy Enterprises, or equal (no known equal.)
- B. Material: Polyurethane behrdesopan
- C. Attributes:
 - 1. 2.25 inch by 2.75 inch hot stamped with 1-1/8 inch black letters on a yellow background.
 - 2. Indicates controller letter or number and valve station number.

2.14 MARKING TAPE

- A. Marking tape shall be a detectable underground utility marking tape as follows:
 - 1. It shall consist of a minimum 4.0 mil (0.004) thickness, inert 100% linear low-density polyethylene plastic film formulated for extended use underground.
 - 2. The tape tensile strength shall be in accordance with ASTM D882 and not be less than 4100 MD and 3650 TD.
 - 3. Elongation properties shall be in accordance with ASTM D882 and be greater than 550%+ at break point.
 - 4. Tape flexibility shall be in accordance with ASTM D671 and shall remain pliable.\
 - 5. The materials shall be acid and alkali resistant.
 - 6. Width of warning tape shall be 6-inch.
- B. Color Coding: The tape shall conform to the American Public Works Association color code as follows:
 - 1. Recycled/Recycled Water Pipelines: Tape color shall alert purple.
- C. Message Inscription: The tape shall include an inscription in black letters to identify the type of utility pipeline on or over which it is installed. The inscription shall be impregnated with colorfast, lead-free, organic pigments suitable for direct burial and prolonged exposure to the elements normally encountered in moderately corrosive type soils. The height of the message letters shall be 1.5 inches minimum, and the message inscription shall be repeated at approximately 3-foot intervals. The message inscription for the different types of pipelines shall be as follows:
 - 1. Recycled/Recycled Water Pipelines: The message on the tape shall be:

"CAUTION RECYCLED/RECYCLED WATER LINE BURIED BELOW"

- D. Warning tape shall be manufactured by T. Christy Enterprises, Inc., or approved equal. Model for recycled water: TA-DT-6-PRW.

2.15 MISCELLANEOUS INSTALLATION MATERIALS

- A. Solvent cement and primer for solvent weld joints: make and type approved by manufacturer(s) of pipe and fittings. Maintain cement at proper consistency throughout use. IPS Weld-On, Oatey, or approved equal.
- B. Pipe joint compound: non-hardening, non-toxic materials designed specifically for use on threaded connections in water carrying pipe. Rectorseal T+2 pipe thread sealant or approved equal.
- C. Pipe lubricant: All-purpose pipe lubricant shall be used for assembling gasketed PVC pipe. Pipe Lubricant is a mixed fatty acid soap dispersed in glycols and water solvents with a clay pigment filler. Pipe lubricant can be applied from -10° F to 150° F. It will not deteriorate natural or synthetic rubber, plastic gaskets, cast or ductile iron pipe. Pipe lubricant contains no petroleum oils or phosphates and will not support bacterial growth. Oatey or approved equal.

2.16 MISCELLANEOUS EQUIPMENT

- A. Provide all equipment called for by the Drawings.

PART 3 INSTALLATION

3.01 PREPARATION

- A. General: Prior to all work of this section, carefully inspect the installed work of all other trades and verify that their work is complete or to the point where this installation may properly commence. Verify that irrigation system can be installed in strict accordance with pertinent codes and regulations, the original design, the referenced standards and the manufacturer's recommendations.

In the event any equipment or methods indicated on the Drawings or in Specifications conflicts with local codes, immediately notify the inspector prior to installing. If this notification is not provided, assume full responsibility for the cost of all revisions necessary to comply with code.

Grades: Before starting work, carefully check grades to determine that work may safely proceed, keeping within the specified material depths with respect to finish grade.

Coordination with work of other trades: Provide all necessary measurements in the field to ensure precise fit of items in accordance with the original design. Coordinate the installation of irrigation materials with all other work. Give special attention to coordination of piping locations with new and existing signage, light standards, hydrants, and other utility locations to avoid conflicts.

- B. Recycled Water Supply: Connect the water supply to locations as shown on the Drawings. Make minor changes caused by actual site conditions at no additional cost to the District. All required testing shall be successfully completed prior to connection.

3.02 HANDLING AND STORAGE

- A. Protect work and materials from damage during construction and storage as directed by the District.

- B. Handle plastic pipe carefully; especially protect it from prolonged exposure to sunlight.

3.03 LAYOUT

- A. Lay out work in accordance with diagrammatic construction Drawings.
- B. Stake out the irrigation system as shown on the Drawings. Obtain approval from the District before starting work.
- C. Where site conditions do not permit location of piping, valves and heads where shown, notify the District immediately and determine relocation in joint conference.
- D. Run pipelines and automatic control wiring in common trenches wherever practical. When pipe and wire area placed in the same trench, it is required that a minimum separation of 3 inches shall be maintained between pipes and/or pipes and wiring.
- E. Irrigation heads, valves, and boxes shall not be placed in the path of sports play, gates, or vehicular/pedestrian traffic. Determine the proper locations at the time of staking the irrigation system.
- F. During spray or rotor head layout do not exceed the maximum operating radius of the spray heads at 30 psi or rotor heads at 60 psi.

3.04 EXCAVATING AND TRENCHING

- A. Excavate trenches ample in size to permit the pipes to be laid at the elevations intended and to permit ample space for joining. When two pipes are to be placed in the same trench, maintain a 3-inch minimum separation between pipes.
- B. Make trenches for pipelines deep enough to provide minimum cover from finish grade as follows:
 - 1. 2.5-inch and smaller main line pipe: 18-inch minimum cover over main line.
 - 2. Lateral line pipe: 12-inch minimum cover.
 - 3. Low voltage wire: 18-inch minimum cover.
- C. Restore surfaces, existing underground installations, utilities, plant materials, etc., damaged or cut as a result of excavations, to original conditions in manner approved by the District.
- D. Where other utilities interfere with irrigation trenching and pipe work, adjust the trench depth as instructed by the District.

3.05 ASSEMBLING PIPELINES

- A. Assemble pipe free from dirt and pipe scale. Ream field cut ends to full pipe diameter with rough edges and burrs removed.
- B. Solvent-Weld Main Line: At changes in direction or branch mains, use appropriate Schedule 40 PVC fittings as approved by the Uniform Plumbing Code.
- C. Solvent Weld Joint:
 - 1. Prepare joint by first making sure the pipe end is square, then deburring the pipe end and cleaning pipe and fittings of dirt, dust and moisture.
 - 2. Dry-insert pipe into fitting. Pipe should enter fitting 1/3 to 2/3 depth of socket.
 - 3. Coat the inside of socket surface of the fitting and the external surface of the male end of the pipe with solvent cement primer (P-70 as manufactured by Weld-On or approved equal). Then without delay, apply solvent cement (Weld-On 711 as manufactured by Weld-On or approved equal) liberally to the male end of the pipe and apply solvent cement lightly to the inside of the socket. Now, apply a second coat of solvent cement to

- the pipe end. (Solvent cement with primer incorporated into the solvent cement may be used.)
4. Insert pipe immediately into fitting and turn $\frac{1}{4}$ turn to distribute cement and remove air bubbles. The pipe must seat to the bottom of the socket and fitting. Check alignment of the fitting. Align the pipe and fitting properly to prove no strain to either.
 5. Hold joint still for approximately thirty (30) seconds and then wipe excess cement from the pipe and fitting.
 6. Cure joints a minimum of thirty (30) minutes before handling and at least six (6) hours before allowing water in the pipe.
- D. Threaded Joint:
1. Field threading of plastic pipe or fittings is not permitted. Provide factory-formed threads only.
 2. Field-cut threads in metallic pipe will be permitted only where necessary. When field threading, cut threads accurately an axis with sharp dies.
 3. Provide threaded joints with pipe joint compound. Apply compound to male threads and first two female threads only.
 4. Where assembling metallic pipe to metallic fitting or valve, no more than one full turn beyond hand tight.
 5. Where assembling to threaded plastic fitting, take up joint no more than one full turn beyond hand tight.
 6. Where assembling soft metal (brass or copper) or plastic pipe, use strap type friction wrench only; do not use metal-jawed wrench.
- E. Cap or unplug openings as pipeline is assembled to prevent entrance of dirt or obstruction. Remove caps or plugs only when necessary to continue assembly.
- F. Where pipes or control wires pass through sleeves, provide removable non-decaying plug at ends of sleeve to prevent entrance of earth.

3.06 SLEEVES AND ELECTRICAL CONDUIT

- A. Install sleeves to carry main line pipe, lateral line pipe, and wire under concrete and asphalt surfaces. Provide a sleeve even if the Drawings do not indicate a sleeve under the concrete and asphalt surfaces.
- B. Install pvc electrical conduit to carry control wires under concrete and asphalt surfaces where a sleeve does not exist for main and/or lateral line pipe.
- C. Install pvc electrical conduit to carry control wires under soil, concrete, and asphalt surfaces for master control valve and flow sensor cable. Provide a separate conduit for each item.
- D. Sleeves and/or conduit under existing paving: Bore for sleeves and/or conduit under existing paving and extend 12 inches beyond paving edge. Provide a separate sleeve for each water line and conduit for electrical control wires.

3.07 REMOTE CONTROL VALVES

- A. Install where shown and on Drawings and group together where practical. Provide only remote control valve per box without exceptions.
- B. Locate valve boxes 12 inches from and perpendicular to hardscape edges and walls.
- C. Provide a 12-inch clearance between valve boxes where valves are grouped together.
- D. Thoroughly flush main line before installing valve.
- E. Install in shrub or ground cover areas rather than turf areas where possible.

- F. Where installed in turf areas, do not install in "field of play" or play side lines or goal areas.
- G. Adjust remote control valve flow stems as follows:
 - 1. The most remote sprinkler heads operate at the pressure recommended by the head manufacturer.
 - 2. Uniform distribution of water is applied by the sprinkler heads to the planting areas.
- H. Label control line wire at each valve with a 2-1/4-inch x 2-3/4-inch polyurethane I.D. tag, indicating identification number of valve (controller and station number). Attach label to control wire.

3.08 QUICK COUPLING VALVES

- A. Install where shown and on Drawings.
- B. Locate valve boxes 12 inches from hardscape edges and walls.
- C. Thoroughly flush main line before installing valve.
- D. Install in shrub or ground cover areas unless unavoidable.

3.09 VALVE BOXES

- A. Provide and install remote control valves, gate valves, or other valves in a valve box as shown in details, complete with cover bolted to valve box at the finish of work.
- B. Set valve boxes to finish grade in turf areas and 2 inches above finish grade in groundcover areas.
- C. Install one remote control valve in one valve box - no exceptions.
- D. Do not allow valve boxes to rest on pipes.
- E. Provide a 2-inch minimum clear distance between valve and the box wall.
- F. Install valve boxes located near walks, curbs, headerboards and paving in such a way as to allow for valve boxes to abut those items with top lid surface matching plane of items listed above.

3.10 AUTOMATIC CONTROL WIRING

- A. Run wires along mains wherever practical. Tie wires in bundles with pipe wrapping tape at 10-foot intervals and allow slack for contraction between strappings. Do not tape wire together where contained within sleeving of conduit.
- B. Loop a minimum of three (3) feet of extra wire in each valve box; control wire, spare wire and common ground wire.
- C. Provide an expansion curl within three (3) feet of each wire connection and at least every 100 feet of wire length on runs more than 100 feet in length. Form expansion curls by wrapping at least 5 turns of wire around a 1 -inch diameter pipe, then withdraw the pipe.
- D. Make connections by crimping bare wires with brass connectors and sealing with splice kits as detailed.
- E. Field splicing will be permitted only upon inspection and written approval from the District. Locate splices at valve locations within valve boxes.
- F. Where control lines pass under paving, install wire in Schedule 40 electrical PVC conduit or inside a sleeve for irrigation pipes.

3.11 CONTROLLER

- A. The controller is existing. Refer to LUHSD field improvement irrigation plans and site.
- B. Connect control lines to controller in sequential arrangement per assigned identification number of valve. Label each control line wire at controller with a permanent, non-fading label indicating station number of valve controlled. Attach label to control wire.
- C. Arrange for the entire controller and installation to be approved and certified by the vendor (SiteOne-GreenTech) in writing. Provide written certification to the District.

3.12 BACKFILLING

- A. Obtain Architect's approval for valve manifolds, gate valves, main line pipe, and lateral line pipe prior to backfill at these items.
- B. Backfill only after piping has been tested, inspected and approved by the District.
- C. Backfill material: earth excavated from the trenches, free from rocks, concrete chunks and other foreign or coarse materials.
- D. Place backfill materials in 4-inch layers and compact to between 85 and 90% relative compaction.
- E. Dress areas to finish grades and remove excess soil, rocks or debris remaining after backfill is completed.
- F. If settlement occurs along trenches, and adjustments in pipes, valves and sprinkler heads, soil, sod or paving are necessary to bring the system, soil, sod or paving to the proper level or the permanent grade, as part of the work under this Contract, make all adjustments without additional cost to the District.

3.13 ROTOR, SPRAY, AND BUBBLER HEADS

- A. Thoroughly flush lines before installing heads.
- B. Locate heads as shown in the Drawings and detail.
- C. Adjust heads for proper distribution and trim.
- D. Install turf heads 2 inches above grade in seeded lawn area at time of installation. Lower to finished grade after turf is well established and as directed by the District.

3.14 TESTS

Perform tests as specified below. Remake any faulty joints with new materials. Use of cement or caulking to seal leaks is absolutely prohibited.

- A. Record Prints: No testing or system observation shall commence without "record" prints. In the event the Contractor calls for testing or system observation without up to date "record" prints, without completing previously noted corrections, or without preparing the system for testing or system observation, the testing or system observation will be canceled and the Contractor will be charged for the direct costs of all District personnel's time and consultant's time lost. Testing or system observation will be required for:
 - 1. Cross-connection control testing
 - 2. Pressure test of irrigation main line.
 - 3. Coverage test.
 - 4. Start of maintenance period.
 - 5. Final acceptance.

- B. Notify LUHSD at least three (3) days in advance of testing.
- C. Perform testing at no additional expense to the District and in the presence of the District.
- D. Center load piping with small amount of backfill to prevent arching or slipping under pressure. No fitting shall be covered.
- E. Pipe test for solvent welded main line: Apply the following tests after weld plastic pipe joints have cured at least 24 hours:
 - 1. Prior to the installation of any valves to the main line, flush pipes with water and fully expel air from piping. Cap ends of pipe and test pressure lines with the line fully charged with water.
 - 2. Test live (constant pressure) piping hydrostatically at 125-psi minimum. Lines will be approved if test pressure is maintained for six (6) hours. Contractor shall make tests and repairs as necessary until test conditions are met.
 - 3. Test RCV controlled (lateral) lines prior to installation of sprinklers or bubblers with water at line pressure and risers capped, and visually inspect for leaks. Retest after correcting defects.
- F. Coverage Test: When the irrigation system is completed, perform a coverage test in the presence of the District to determine if the water coverage for planting areas is complete and adequate. Provide this test prior to planting. Overspray that causes runoff to non-landscaped areas such as storm drain system, streets, or waterway shall not be permitted. Overspray on drinking fountains, picnic areas, and non-turf play areas shall not be permitted.
- G. Testing of Electrical System:
Prior to acceptance of the work, provide the following tests to wiring:
 - 1. Continuity test of each circuit.
 - 2. Ground fault of each circuit.
 - 3. A functional test to demonstrate that each part of the system functions as specified or intended herein.

3.15 GUARANTEE

- A. Unconditionally guarantee the entire sprinkler system for material and installation, including settling of backfilled areas below grade for a minimum period of one year following the date of final acceptance of the work.
- B. Submit a guarantee on Contractor letterhead as follows:

We hereby guarantee that the sprinkler irrigation system we have furnished and installed is free from defects in materials and workmanship, and the work has been completed in accordance with the Drawings and specifications, ordinary wear and tear and unusual abuse, or neglect excepted, and that the work, materials and equipment as installed will fulfill the requirements of the guarantee included in the specifications. We agree to repair or replace any or all our work, together with any other adjacent work which may be displaced by doing so, that may prove to be defective in materials and installation within a period of one (1) year from date of acceptance of the below named project in the District, at no additional cost to the District. We shall make such repairs or replacement of the work within seven (7) calendar days of written notification by the District. When the immediate repair or replacement of the work is necessary to ensure the public safety and welfare, which would be endangered by continued usage of the facility, such circumstance will be deemed an operational emergency. In the event of such an emergency after the District contacts our firm and after authorizing 24 hours to initiate repairs, if we fail to initiate and diligently complete such repairs in a timely manner, the District may direct District forces to perform such functions as may be necessary to correct the work and immediately place the facility back in operations condition. If such procedure is implemented, we shall bear all expenses

incurred by the District. In all cases, the judgment of the District shall be final in determining whether an operational emergency exists. In the event of our failure to make such repairs or replacements within the times specified after receipt of written notice from the District (other than an operational emergency), we authorize the District to proceed to have said repairs or replacements made at our expense and we will pay the costs and charges therefore upon demand.

PROJECT: _____

LOCATION: _____

SIGNED: _____

ADDRESS: _____

PHONE: _____

- C. If, within one year following acceptance of the work, settlement occurs and adjustments in pipes, valves and sprinkler heads, sod or paving is necessary to bring the system, sod or paving to the proper level of the permanent grades, as part of the work under this Contract, make all adjustments without extra cost to the District, including the complete restoration of all damaged planting, paving or other improvements of any kind.
- D. Should any operational difficulties in connection with the sprinkler system develop within the specified guarantee period which in the opinion of the District may be due to inferior material and/or workmanship, correct said difficulties immediately and to the satisfaction of the District and at no additional cost to the District, including all other damage caused by such defects.

3.16 CLEAN UP

- A. Upon completion of the work, and at the end of each day, smooth all ground surfaces; remove excess materials, rubbish, debris, etc., sweep adjacent streets, curbs, gutters and trails and remove construction equipment from the premises.

3.17 MAINTENANCE

- A. Properly and completely maintain the irrigation system. Maintain a balanced water program to ensure proper germination and growth until acceptance of the work. Plants which cannot be watered sufficiently with the irrigation system shall be watered by means of a hose.
- B. All controller shall have each station individually adjusted on a weekly basis. Program controller considering the application rate each area can receive. Operate the system on short intervals, with the cycle repeating later to reduce runoff. Program the irrigation system to operate between dusk and dawn (nightly) only and during non-windy hours.

3.18 TURNOVER ITEMS

- A. Controller Charts:
 - 1. The District must approve record prints before charts are prepared.
 - 2. Provide one controller chart (of the maximum size controller door will allow) for automatic controller. Chart shall show the area covered by controller.
 - 3. The chart shall be a reduced copy of the actual "record" print. In the event the controller sequence is not legible when the print is reduced, enlarged to a readable size.
 - 4. Color code the chart with a different color to show the area of coverage for each station.
 - 5. When completed and approved, hermetically seal the chart between two pieces of plastic, each piece being minimum 20 mils in thickness. Install the chart in the controller enclosure using weatherproof Velcro fasteners.
 - 6. Controller charts are to be completed prior to final observation.
- B. Operation and Maintenance Manuals: Within 10 calendar days prior to acceptance of construction, prepare and deliver to the District all required descriptive materials, properly prepared in two individually bound copies of the operation and maintenance manual. The manual shall describe the material installed and be in sufficient detail to permit operating personnel to understand, operate and maintain all equipment. Include spare parts lists and related manufacturer's information for each equipment item installed. Each complete, bound manual shall include the following information:
 - 1. Index sheet stating Contractor's address and telephone, including names and addresses of local manufacturer's representative.
 - 2. Complete operating and maintenance instructions on all major equipment.
- C. Materials to be furnished:
 - 1. Supply as part of the contract the following spare parts:

- a. 4 percent additional sprinkler head and bubblers of each type and spray pattern shown.
 - b. Two (2) wrenches for disassembly and adjustment of each type sprinkler head and bubbler installed.
 - c. One (1) coupler with a $\frac{3}{4}$ inch bronze hose bib, bent nose type with hand wheel and one (1) coupler key.
 - d. "As-built" mylars from "record" prints.
2. Turnover the above spare parts to the District at the final observation.

END OF SECTION

SECTION 32 9000
LANDSCAPE PLANTING

PART 1 GENERAL

1.01 SUMMARY

- A. Drawings and general provisions of the Contract, including General and Supplementary Conditions apply to this Section.
- B. Work Included:
 - 1. Furnish all plant materials.
 - 2. Furnish all labor, equipment and materials necessary for landscape planting installation and maintenance according to these Specifications.
- C. Related Work:
 - 1. Section 32 8000: Irrigation System
 - 2. Irrigation system shall be installed and operative before beginning planting operation. Contractor shall fully acquaint themselves with the existing conditions, particularly in reference to underground piping. Any damage caused by the Contractor to work of other trades shall be repaired by them at no cost to the District.

1.02 COORDINATION

- A. Coordinate work fully with all other trades involved. Coordinate with items of other trades to be furnished and set in place. Such portions of their work as is all or in part embedded, built-in, attached to, or supported by the work shall be executed by them in ample time that progress of the work is not delayed. Contractor shall be responsible for the proper installation of all items related to this section.
- B. Contractor shall coordinate with the Architect and fully acquaint themselves with the existing conditions particularly in reference to any existing underground piping. Any damage caused by the Contractor to work of other trades shall be repaired by them at no cost to the District.

1.03 REFERENCE

- A. Perform work in accordance with all applicable laws, codes and regulations, as required by the Architect.
- B. Reference to "Standard Specifications" shall mean the current Standard Specifications of the State of California, Business and Transportation Agency, Department of Transportation, CALTRANS.

1.04 QUALITY ASSURANCE

- A. Personnel:

All planting shall be performed by personnel familiar with planting procedures under the supervision of a qualified foreman.
- B. Codes and Standards:

Nursery stock shall meet the standards of the current edition of the "Agricultural Code of

California” and the “Regulations of the Director of Agriculture Pertaining to Nursery Stock” as to grading and quality. They shall be true to type and name in accordance with “Standardized Plant Names, Second Edition.”

- C. Substitutions:
No substitutions shall be permitted without approval of the Architect. The District reserves the right to require the Contractor to replace at the Contractor’s cost any plants which the Contractor has installed without the Architect’s approval.
- D. Plants shall be subject to inspection and approval of the Architect at place of growth or upon delivery for conformity to specifications. Such approval shall not impair the right of inspection and rejection during progress of the work.

1.05 SUBMITTALS

- A. Plant Certification:
All plants must meet specifications of Federal, State and County laws requiring inspection for plant disease and insect infestations. Inspection certifications required by law shall accompany each shipment, invoice and order for stock.
- B. Plant Material:
Contractor shall submit nursery sources for all plant material, clearly stating Botanical Name and container size. Additionally, Contractor shall submit photos from the sources and size specification including container size, height, diameter, and trunk caliper.
- C. Sod:
Contractor shall submit written certificates stating quantity, type, composition, and source for all sod.
- D. Topsoil, Amendment and Fertilizer:
Provide current, accurate analysis from an approved testing laboratory.
- E. Mycorrhizae planting backfill.
- F. Soils Fertility Laboratory Test Results
- G. Mulch and Landscape Fabric as indicated on the Drawings.

1.06 JOB CONDITIONS

- A. Delivery:
 - 1. Deliver fertilizer and amendments to site in original, unopened containers bearing manufacturer’s guaranteed chemical analysis, name, trade mark and conformance to state law.
 - 2. Deliver plants with identification labels.
 - (a) Labels shall state correct name and size.
 - (b) Use durable, water-proof labels with water resistant ink that will remain legible for at least 60 days.
 - 3. Protect plant materials during transport to prevent damage to rootball or desiccation of leaves.
 - 4. Remove unacceptable plant materials immediately from job site.
- A. Storage:

1. Contractor shall maintain the plant material properly between delivery and planting. This includes protection from animals and vandals; proper watering, and feeding when necessary.
2. Shade plants shall be stored in the shade, and sun plants shall be stored in the sun.

B. Timing:

Under no circumstances shall any work be performed when the temperature exceeds 90 degrees or is below 40 degrees. No planting shall be done with the soil saturated with water.

PART 2 PRODUCTS

2.01 SOIL AMENDMENTS

A. The following Top Soil, organic amendments, and fertilizer rates and quantities are to be used for bid basis only. Contractor shall arrange and pay for testing by an accredited soils laboratory of existing site soil after rough grading operations are complete, and shall amend the soils according to said laboratory's recommendations. The soils recommendations shall be considered a part of this specification.

B. Topsoil: Provide topsoil as required to complete landscape work.

1. Topsoil may include clean on-site material that has been previously stripped from the top 6 inches of original grade or acceptable import material (as applicable). Acceptable topsoil shall be free from "rocks" (rock, stones, rubble, clay clods, etc. over 1" in diameter), roots, toxins, and any other deleterious material per the discretion of the Architect. All import topsoil proposed for use shall be submitted to the Architect for review and acceptance prior to use. Submit samples and current soil fertility and structure analyses for approval by the Architect.
2. Topsoil to be furnished shall be fertile and friable, possessing characteristics of representative productive soils on the site. It shall not contain toxic substances which may be harmful to plant growth. When herbicide contamination is suspected then a radish/rye grass growth trial must be performed. Consult with the Architect prior to decision to test. It shall be uniformly textured and free of all objectionable foreign materials, oil or chemicals which may be injurious to plant growth. Natural topsoil shall possess a pH factor between 5.5 and 7.5, a sodium absorption ratio (SAR) of less than 8, a boron concentration of the saturation extract of less than 1 ppm, and salinity of the saturation extract at 25 degrees C. of less than 4.0 millimhos per centimeter. Obtain topsoil from naturally well-drained sites where topsoil occurs in a depth of not less than four inches (4"); do not obtain from bogs or marshes.

C. Organic Amendment:

1. Physical Properties: A minimum of 90% of the material by weight shall pass a 1/2" screen. Material passing the 1/2" screen shall meet the following criteria:

| % Passing | Sieve Designation | |
|-----------|-------------------|--------|
| 85-100 | 9.51 mm | 3/8" |
| 50-80 | 2.38 mm | No. 8 |
| 0-40 | 500 micron | No. 35 |
2. Source material: Fully composted organic green waste.
3. Carbon and Nitrogen ratio: Maximum 35:1 if material is claimed to be nitrogen stabilized.
4. Organic matter: Minimum 50% based on dry weight and determined by ash method. Minimum 270 lbs. organic matter per cubic yard of compost.

5. Iron content: Minimum 0.08% dilute acid soluble iron based on dry weight; iron treated.
6. Salinity (ECe): 4.5 dS/m maximum @ 25 degrees C. as determined in a saturation extract.
7. Reaction (pH): Minimum: 5.5, Maximum: 8.0 as determined in saturated paste.
8. Moisture content 35% - 60%.
9. Contaminants: the compost shall be free of contaminants such as glass, metal and plastic.
10. Maturity: Shall exhibit visible characteristics of maturity, including: dark brown to black color. Acceptable odor: moldy/musty, soil like, or none. Unacceptable odor: sour, ammonia or putrid.
11. Appearance: Identifiable wood pieces are acceptable, but the balance of the material should be soil like, without recognizable leaves.

D. Fertilizer:

1. Fertilizer shall be a commercial inorganic fertilizer in the granular or pelleted form. Fertilizer shall be delivered to the site in containers labeled in accordance with the applicable State of California regulations, bearing the warranty of the producer or the grade furnished, and shall be uniform in composition, dry and free-flowing.
2. Planting Areas:
 - (a) 6N-20P-20K, and 16-6-8, pelleted type.
 - (b) Sulphate - sulphur
 - (c) Lime for pH adjustment of moderately acid soil
 - (d) Starting one (1) month after planting, on a monthly basis, 21N-0P-0K Ammonium sulfate. 5 lbs. per 1,000 square feet.

E. Mycorrhizae Planting Backfill:

1. MycoApply Endo/Ecto Plus, available from Mycorrhizal Applications, Inc., www.mycorrhizae.com.

2.02 CONTAINER PLANTS

- A. All plant materials shall be nursery grown in accordance with the best known horticultural practices and under climatic conditions similar to those in the locality of the project.
- B. Plants shall be vigorous and shall have a normal habit of growth. Plants shall be free of damage by insects, pests, diseases or wind; burns from insecticides or fertilizer; and stunted growth due to lack of water, lack of food, diseases or other causes. Plants shall be in conformity with the sizes shown on the Drawings.
- C. Quantities:
 1. Quantities necessary to complete the work as shown on the Drawings shall be furnished.

2.03 TURF

- A. Sod:
 1. Sod shall be as specified on the Drawings.

PART 3 INSTALLATION

3.01 SURFACE CONDITIONS

- A. Inspections by the Landscape Contractor:

1. Prior to all work in this section, verify grades and carefully inspect the installed work of all other trades. Verify that all such work is complete to the point where the installation may properly commence.
2. All planting areas shall contain a minimum of eight (8) inches of acceptable topsoil. As applicable and where needed, only previously acceptable topsoil shall be installed.
3. Inspect plant materials for injury, insect infestations and proper pruning.
4. Landscape Contractor shall receive site graded to plus or minus one-tenth of a foot (0.10') of finish grades shown on the Drawings. Allow for depth of soil amendments and mulch in determining the difference between finished subgrade in groundcover and shrub beds. Verify that subgrades are not compacted.
5. Landscape Contractor shall over excavate planting beds along the perimeter of lime treated areas to remove excess lime that was added for construction. Refer to geotechnical report for required overbuild and depth of lime to determine extent of removal. Provide new topsoil in these planting areas.
6. Contaminated Soil:
 - (a) Do not perform any soil preparation work in areas where soil is contaminated with cement, plaster, paint or other construction debris. Bring such areas to the attention of the Architect and do not proceed until the contaminated soil is removed and replaced.
 - (b) Contaminated soil shall be removed to full depth of contaminants with a minimum depth of 12 inches and replaced with acceptable topsoil.
7. Moisture Content: Soil shall not be worked when moisture content is so great that excessive compaction will occur, nor when it is so dry that dust will form in the air or that clods will not break readily. Water shall be applied, if necessary, to bring soil to an optimum moisture content for tilling and planting.
8. Soil Loosening: Soil in all planting areas (only) shall be ripped or cultivated to the depths specified below. Water shall be added and ripping or cultivating shall be continued until the entire specified depth is loose and friable. All debris, pavement, concrete, and rocks over 1 inch in diameter shall be removed to the specified depth and shall be removed from the site and disposed of properly.
 - (a) Slopes 2½ horizontal to 1 vertical and steeper: No loosening required.
 - (b) All other areas to be planted: 12 inches deep.
9. Weed Control and removal:
 - (a) Remove all weeds and other debris prior to any soil preparation or grading work. Weeds and debris shall be disposed of off the site properly.
 - (b) Grow and Kill: After grading finish is complete, apply water in sufficient quantity over a minimum period of 14 days to germinate weed seeds. When weeds have germinated, kill them and remove them in a manner acceptable to the District and that will not have a detrimental residual effect on the growth and vigor of the landscape planting work. Provide temporary irrigation as required to apply the water.
10. In the event of discrepancy, immediately notify the Architect. Do not proceed with this installation in areas of discrepancies until all such discrepancies have been fully resolved.

3.02 SOIL PREPARATION

- A. In the areas designated for landscaping on the Drawings except for bioretention areas and within tree protection zones, Contractor shall, prior to placing imported material, replacing existing topsoil before doing any planting, verify that the areas are clear and free of weeds, roots, debris, rocks and underground obstructions, and construction debris to a depth acceptable for planting. Scarify the subgrade to a four inch (4") minimum depth prior to

spreading topsoil. Finished grades shall be approved by the Architect prior to commencing soil preparation and planting operations.

B. Cultivation and Placement of Amendment:

1. In planting areas except for bioretention areas and within tree protection zones, cultivate soil to a depth of eight inches (8"). Prior to planting, incorporate six (6) cubic yards per 1,000 square feet of nitrified fir bark, and the following fertilizers, per 1,000 square feet: 30lbs. 6N-20P-20K to a depth of six inches (6").

C. Finish Preparation:

1. After approval of amendment and fertilizer applications by the Architect, incorporate into the top six inches (6") of soil by repeated rotary-hoe cultivation except within tree protection zones.
2. When rough grading and soil conditioning has been completed, all planting areas shall be smooth graded, ready for placement of plant materials and for seeding/sod. Grading shall be done when soil is at optimum moisture content for working.
3. Finished grades shown on the Civil Drawings are given in feet and decimals of feet. Slope uniformly between given spot elevations. Planting areas shall be true to grade within one inch when tested in any direction with a 10 foot straightedge.
4. Grades not otherwise indicated shall be uniform levels or slopes between points where elevations are given or between points established by walks, paving, curbs or catch basins. Finished grades shall be smooth even and on a uniform plane with no abrupt change of surface. Minor adjustments of finish grades shall be made at the direction of the Architect if required.
5. All grades shall provide for natural runoff of water without low spots or pockets. Flow line grades shall be accurately set and shall not be less than 2 percent gradient wherever possible unless otherwise indicated on the Drawings.
6. Tops and toes of all slopes shall be rounded to produce a gradual and natural-appearing transition between relatively level areas and slopes.
7. Roll to compact amended soil to not more than 85% compaction.
8. Finish out to a smooth, even surface conforming to established grades after settlement. Rake immediately prior to planting.
9. If rain is likely between completion of soil preparation and planting, precaution shall be taken to prevent erosion of the soil.

3.03 CONTAINER PLANTS

A. Preparation:

1. Place plants in containers in the locations indicated on the Drawings and obtain the approval of the Architect before digging. Maintain plants as required for optimal condition until approved for installation.
2. The Contractor shall protect all utilities, vegetation and structures during work.

B. Excavation:

1. All plant pits shall be dug circular in outline and with vertical walls. The sides and bottoms of all planting pits shall be thoroughly scarified.
2. Holes for fifteen (15) gallon size plants or larger: twenty-four inches (24") wider than the can or rootball.

3. After pits are dug, break sides to open wall of pit for root penetration and loosen bottom of pit to a depth of three inches (3"). Construct a foot tamped mound in bottom of pit to support plant at proper level.
 4. Following excavation of planting holes and prior to placing backfill, fill planting hole with water to a depth of 6", and allow water to percolate into existing soil for 24 hours. Any planting holes not drained within 24 hours shall have drainage holes drilled to a depth that allows planting hole to drain or install subdrain from planting pit to storm drain system as directed by the Architect. After drilling drainage hole or installing subdrain, refill with water and repeat process above as directed by the Architect.
- C. Plants in Containers:
1. Plants shall be removed carefully from their containers after the containers have been cut on two (2) sides minimum; fifteen (15) gallon containers shall be opened in three (3) places.
 2. After removing plant material from its container, stimulate root growth by making four (4) or five (5) vertical cuts, one inch (1") deep around the circumference of the rootball.
 3. Do not lift or handle plants by the top, stems or trunk at any time. All plants shall be lifted in such a manner that the rootball is supported from the underside.
 4. The Contractor shall check all plants for adequate root systems. When the root system is defective, he shall remove deficient plants from the site and replace them with new ones with adequate root system.
- D. Planting:
1. Center plant in pit or trench over tamped mound.
 2. Face for best effect.
 3. Set plant plumb and hold rigidly in position.
 4. All plants shall be set in the ground so that the rootball will be flush with the finish grade. All plants that settle below the finish grade within thirty (30) days of acceptance of the work shall be replanted in the proper position. In case a total section of planting area settles, the Contractor shall lift the plants, import additional soil mix, regrade and replant, at no additional cost to the District.
 5. Use amended soil mix only for backfill. Backfill pit with soil mix in nine inch (9") layers and water each layer thoroughly to settle soil. The filled pit shall be flush with surrounding grade when complete.
 - (a) In the top 1" of the plant hole, mix Mycorrhizae planting backfill with the plant backfill. Evenly distribute the Mycorrhizae and place as close to rootball as possible at the following rates.
 - 4" pot or Liner: 1 teaspoon
 - # 1 gallon: 1 tablespoon
 - # 5 gallon: 4 tablespoons
 - # 15 gallon: 6 tablespoons
 - 24" box: 8 tablespoons
 6. When the plant pit has been approximately one-half (1/2) filled, place planting tablets according to the manufacturer's schedule.
 - (a) Planting areas shall be hand raked to remove all clods, weeds, roots, debris, and rocks 1-inch in diameter and larger.
 7. Dispose of excess excavated soil (if any) on the site at no additional cost to the District.

3.04 TURF

- A. Turf shall be as indicated on the Drawings.
- B. After soil preparation, turf areas shall be graded to drain and shall be smooth and uniform prior to placing sod. Areas shall be hand raked to remove all clods, weeds, roots, debris, and rocks 1-inch in diameter and larger. After fine grading, rolling, and settlement of the soil, seed or sod shall be placed as shown on the Drawings.
- C. Grading in turf areas that has been established under work of another Section and/or Contract shall be maintained in a true, even condition, equal to when said grades were previously approved by the Architect.
- D. Seed shall be broadcast at the specified rate of application.
- E. Sod shall be placed so that the ends of adjacent strips of sod are staggered a minimum of 2 feet. Edges and ends of sod shall be placed firmly against adjacent sod and against sidewalks, concrete headers, header boards, and other paved borders and surfaced areas. Where no edging is present, Contractor shall cut edge of sod in line indicated on the Drawings and backfill edges with soil. Edges of sod rolls shall not be exposed.
- F. After placement of the sod, the entire sodded area shall be lightly rolled to eliminate air pockets and to ensure close contact with the soil.
- G. Turf areas shall be watered so that the soil is moistened to a minimum depth of 4 inches. Turf areas shall not be allowed to dry out for a minimum of 14 days.

3.05 PROTECTION

- A. Protect all planted areas and plants against trespassing and damage at all times. If any plants are damaged, replace as directed by the Architect with no additional cost to the District.

3.06 CLEAN UP

- A. Upon completion of planting, all cans, boxes and other debris that is a part of the planting operation shall be removed from the site.
- B. All pavements shall be washed off, and site shall be left in an absolutely clean condition. All planting areas shall be cultivated and weed free before final inspection. Clean-up operations shall take place throughout the course of work so that walks and drives are clean at all times.

3.09 INSPECTIONS

- A. Notification: The Contractor shall notify the Architect a minimum of 72 hours before requiring a visit by the Architect.
- B. Check Points: The following shall be considered check points and the Contractor shall only proceed with the work after the Architect has visited the site and determined that the work is proceeding satisfactorily.
 - 1. Completion of rough grading in planting areas.
 - 2. After placement of topsoil, soil amendment and fine grading before planting, seeding or sodding.
 - 3. Layout of plant material. All plant material in the planting area shall be placed in the configuration shown on the Drawings prior to plant pit excavation.
 - 4. Maintenance period shall not start until all construction for the entire project is complete.

5. A check visit shall be made to begin the maintenance period. At this time the Contractor shall have completed all phases of the Drawings and Specifications. Any discrepancies shall be noted at that time and the Contractor shall make appropriate corrections before beginning the maintenance period.

3.10 MAINTENANCE

- A. Contractor shall furnish all labor, material, equipment and services required to maintain the landscape in a healthy and attractive condition for a period of ninety (90) calendar days.
- B. Maintenance shall include fertilization, watering, insect and disease control, weed control (hand or spray), mowing, pruning, restaking, continual checking, adjusting, programming and making all necessary repairs to the automatic irrigation system, cleaning of pavement, replenishment of bark mulch, and weekly trash removal from all project site areas. All chemical use shall conform to District's standards for application and notification.
- C. No later than two (2) calendar weeks prior to the end of the maintenance period, the Contractor shall request in writing a review of the work by the Architect. When, upon review, the Architect finds all project work to be complete, the plant material to be in a healthy condition and all landscape areas to be weed-free and in a neat, orderly condition, then written acceptance of work shall be given by the Architect. When approval and acceptance of the work is not given, the Architect shall prepare a "construction punch list" of items to be completed before acceptance of the work is given. Acceptance shall only then be given upon verification by the Architect that the punch list items have been completed. Maintenance period shall only commence after "construction punch list" items have been completed and approved. "Construction punch list" items shall be completed within the specified construction period to avoid liquidated damages and extension of maintenance period.
 1. All plant material shall be live, healthy, undamaged, vigorous and free from infestations.
 2. All turf areas shall be completely covered at the time of final acceptance, leaving no bare spots. Sod shall be free of all weeds (broadleaf and grass weeds).
 3. Planting areas shall be free of all weeds.
 4. Nursery stakes shall be removed from trees.
- D. The Contractor's maintenance period will be extended when the provisions required within the plans and specifications are not full complete and accepted by the Architect.
- E. Watering:
 1. All plants shall be kept watered as often as it is necessary to keep them in optimum, vigorous growth. Watering shall be done preferably during the early morning hours.
 2. Water shall be controlled so that there will be no excessive run-off, ponding or overwatering.
 3. Root Growth: Periodically the Contractor shall check the progress of the root growth within the back fill area. As the root growth increases beyond the root ball, the frequency of watering shall be reduced so that the roots are encouraged to grow to a lower soil depth. Watering then shall be less frequent, but

applications shall be very slow and the Contractor shall assure that water does penetrate to the depth of the former plant pit.

F. Mowing

1. Winter: Mow grass weekly to 1-1/2" when it reaches height of 2-1/2". Remove no more than 1/3 of the grass blade at each mowing event
2. Other seasons: Mow grass weekly to 2-1/2" when it reaches a height of 3-1/2". Remove no more than 1/3 of the grass blade at each mowing event
3. Biofiltration Sod and Native Mow Free Sod shall be mowed or trimmed with a line trimmer to remove dead growth or remove seed heads as approved by the Architect.

G. Spraying:

1. Plants shall be sprayed with a broad spectrum material that will control the specific pest and any other pests that might normally be anticipated during that part of the season. Preventative spraying shall be done only with the approval of the District.
2. Operators of spray equipment shall take all reasonable precautions to protect themselves, other people and buildings from spray. The Contractor shall publicly notice the use of herbicides and have all permits and licenses required for such an operation. Where applicable, dormant spray shall be applied to shrubs and trees during the winter period.
3. All equipment shall be properly washed before and after use. No spraying shall take place without proper public noticing procedures or during windy or gusty days.

H. Weed Control:

1. Weeds shall be kept under control by hand removal. Herbicides shall only be used when approved by the Architect. Weed all areas at an interval of not more than ten (10) days.
2. Pre-emergent herbicide shall be applied to all tree and turf areas including plant basins. Chemicals used are to be in written chemical control program prepared by a licensed pest control advisor and approved by the Architect. Apply prior to any mulching.
3. All equipment used for herbicides shall be properly cleaned before it is used on this project. Herbicides shall be applied at temperatures recommended by the manufacturers. Herbicides shall not be used during windy or gusty days. All possible precautions shall be taken to protect vegetation which is susceptible to damage from the particular herbicides to be used.
4. The bases of all plants shall be kept completely free of weeds. Periodically, the base of the trees and shrubs shall be cultivated in order to allow better penetration of water, but such cultivation shall be carefully done in order not to destroy surface roots.

I. Fertilization: Topdress all areas at one (1) month intervals from time of planting with fertilizer of same composition and at same rate as at time of planting.

J. Litter: The Contractor shall remove promptly after pruning, trimming and weeding or other work required under the contract, all debris generated by his performance of the work. Walkways, driveways and paved areas shall be vacuumed clean with suitable

equipment immediately after working in these areas. All areas covered by this contract shall be kept free of debris and litter.

3.11 GUARANTEE AND REPLACEMENT

- A. Guarantee period shall be extended for a period of one (1) year from the date of written acceptance.
- B. All plants shall be guaranteed to be alive and healthy as determined by the Architect at the end of the guarantee period.
- C. The Contractor shall replace within two (2) weeks of notice and in accordance with the Drawings and Specifications throughout the guarantee period, any plants that die, or in opinion of the Architect, are in an unhealthy or unsightly condition, and or have lost their natural shape due to dead branches, excessive pruning, inadequate or improper maintenance, or any other causes due to the Contractor's negligence. Any plant that shows 25% defoliation shall be considered unhealthy.

END OF SECTION

SECTION 33 3100

SITE SANITARY SEWERAGE

PART 1 - GENERAL

1.1 RELATED DOCUMENTS

- A. Drawings and general provisions of the Contract, including General and Supplementary Conditions and Division 1 Specification Sections, apply to this Section.

1.2 SUMMARY

- A. This Section includes gravity-flow, non-pressure sanitary sewerage outside buildings, including the following components:
 - 1. Cleanouts.
 - 2. Manholes.
- B. Related Sections include:
 - 1. Section 33 1100 "Site Water Distribution" for underground water lines outside buildings.
 - 2. Section 31 2333 "Trenching and Backfill" for trenching and backfilling for underground sanitary sewer lines, and detectable warning tapes.
 - 3. Section 33 4000 "Site Storm Drainage" for underground storm drain lines outside buildings.
 - 4. Section for sanitary sewer lines within and below buildings.

1.3 DEFINITIONS

- A. DN: Dimension Nominal.
- B. NPS: Nominal Pipe Size.
- C. PVC: Polyvinyl chloride plastic.
- D. SDR: Standard Dimension Ratio, derived by dividing the outside diameter of the pipe by the pipe wall thickness.

1.4 SUBMITTALS

- A. Product Data: For each type of product indicated, including the following:
 - 1. Piping and related specialties.
 - 2. Cleanouts.

- B. Coordination Drawings: Show pipe sizes, locations, and elevations. Show other piping in the vicinity and clearances from sewerage system piping. Indicate interface and spatial relationship between manholes, cleanouts, piping, and proximate structures.
- C. Field quality-control test reports.
- D. Record drawings of installed sanitary sewerage lines and appurtenances in accordance with Division 1 Section for project closeout requirements.
 - 1. Locate and dimension work with reference to permanent landmarks. Indicate materials and sizes of all components.

1.5 DELIVERY, STORAGE, AND HANDLING

- A. Deliver piping with factory-applied end caps. Maintain end caps through shipping, storage, and handling to prevent pipe-end damage and to prevent entrance of dirt, debris, and moisture.
- B. Do not store plastic pipe and fittings in direct sunlight.
- C. Protect pipe, pipe fittings, and seals from dirt and damage.

1.6 PROJECT CONDITIONS

- A. Interruption of Existing Sanitary Sewerage Service: Do not interrupt service to facilities occupied by Owner or others unless permitted under the following conditions and then only after arranging to provide temporary service according to requirements indicated:
 - 1. Notify Architect no fewer than seven days in advance of proposed interruption of service.
 - 2. Do not proceed with interruption of service without Architect's written permission.
- B. Information shown regarding locations of existing utilities is based upon available records and data, but shall be regarded as approximate, only. Make minor deviations necessary to conform to actual locations and conditions without extra cost. Verify location and elevation of utilities prior to commencement of excavation.
 - 1. Exercise extreme care in excavating near existing utilities. Contractor is responsible for damage to existing utilities.

1.7 COORDINATION

- A. Coordinate connection in public right of way with City of Brentwood.
- B. Coordinate placement of cleanouts and manholes with layout of pavement joints and patterns. Refer to Drawings for layout.

- C. Coordinate crossings with other underground utilities.
- D. Coordinate with locations of building connections.

PART 2 - PRODUCTS

2.1 PIPING MATERIALS

- A. Refer to Part 3 "Piping Applications" Article for applications of pipe, fitting, and joining materials.

2.2 PVC PIPE AND FITTINGS

- A. Polyvinyl chloride pipe (PVC) solid wall pipe with fittings for diameter sizes of 3-in through 8-in shall be type PSM SDR-35, ASTM 3034. Couplings and joints shall meet the requirements in ASTM D3212.

2.3 CLEANOUTS

- A. Pipe for cleanout shall be of the same size and material as sanitary sewer line. Refer to Detail shown on the plans.
- B. Frame and cover shall be manufactured of cast iron conforming to ASTM A-48-class 30.
 - 1. Frame and cover shall be HS20-44 rated and shall be coated with bituminous material.

2.4 MANHOLES: Precast reinforced concrete manhole in conformance with ASTM C-478. Manhole base to be precast or cast-in-place. Refer to City of Brentwood standard drawing SS-2.

- A. Size: 48" I.D. with precast reinforced concentric concrete cone.
- B. Lid inscribed with the words "SANITARY SEWER".
- C. All joints shall be set on full mortared bed and banded with mortar on both interior and exterior surfaces.

PART 3 - EXECUTION

3.1 EARTHWORK

- A. Refer to Section 31 2000 "Earthwork" for excavation, trenching, and backfilling.

3.2 PREPARATION

- A. Where connecting to existing sewer lines, verify existing line is free-draining prior to making connection. If required, clean existing line to achieve free-draining condition.

3.3 PIPING APPLICATIONS

- A. Gravity-Flow, Non-pressure Sewer Piping: Use the following pipe materials:
 - 1. NPS 3 (DN 80) to NPS 12 (DN 300): PVC sewer pipe and fittings, gaskets, and gasketed joints.

3.4 PIPING INSTALLATION

- A. General Locations and Arrangements: Drawing plans and details indicate general location and arrangement of underground sanitary sewerage piping. Location and arrangement of piping layout take design considerations into account. Install piping as indicated, to extent practical. Where specific installation is not indicated, follow piping manufacturer's written instructions.
- B. Install piping at low point, true to grades and alignment indicated with unbroken continuity of invert. Place bell ends of piping facing upstream. Install gaskets, seals, sleeves, and couplings according to manufacturer's written instructions for use of lubricants, cements, and other installation requirements.
- C. Install piping free of sags and bends.
- D. Use fittings for changes in direction and branch connections unless indicated otherwise.
- E. Install proper size increasers, reducers, and couplings where different sizes or materials of pipes and fittings are connected. Reducing size of piping in direction of flow is prohibited.
- F. Tunneling: Install pipe under streets or other obstructions that cannot be disturbed by tunneling, jacking, or a combination of both.
- G. Install gravity-flow, non-pressure drainage piping according to the following:
 - 1. Install piping pitched down in direction of flow, at slope indicated, but in no case less than 0.35 percent.
 - 2. Install piping at elevations and inverts indicated, but in no case with less than 36-inch cover.
 - 3. Install PVC sewer piping according to ASTM D 2321 and ASTM F 1668.
- H. Clear interior of piping of dirt and superfluous material as work progresses. Maintain swab or drag in piping, and pull past each joint as it is completed. Place plug in end of incomplete piping at end of day and when work stops.

3.5 PIPE JOINT CONSTRUCTION

- A. Join gravity-flow, non-pressure drainage piping according to the following:
 - 1. Join PVC sewer piping according to ASTM D 2321 and ASTM D 3034 for elastomeric-seal joints or ASTM D 3034 for elastomeric gasket joints.
 - 2. Join dissimilar pipe materials with pressure-type couplings.

3.6 CLEANOUT INSTALLATION

- A. Install cleanouts and riser extension from sanitary sewerage pipe to cleanout at grade. Use cast-iron soil pipe fittings in sanitary sewerage pipes at branches for cleanouts and cast-iron soil pipe for riser extensions to cleanouts. Install piping so cleanouts open in direction of flow in sewer pipe.
- B. Set cleanout frames and covers in earth in cast-in-place concrete block, as detailed on Drawings. Set with top of concrete flush with adjacent paving material, or, if occurring in planted or soil area, 1-inch above surrounding finish grade.

3.7 MANHOLE INSTALLATION

- A. Install manholes to grade specified on plans. Manhole base to be precast or cast-in-place concrete.

3.8 CONNECTIONS

- A. Connect non-pressure, gravity-flow sanitary sewerage piping to building sanitary sewer lines, as indicated on Drawings.
 - 1. Refer to Division 15 Section for plumbing sanitary sewer lines occurring inside and below buildings.
- B. Make connections to existing sanitary sewer piping.
 - 1. Use commercially manufactured wye fittings for piping branch connections. Remove section of existing pipe; install wye fitting into existing piping; and encase entire wye fitting, plus six-inch overlap, with not less than six inches of concrete with 28-day compressive strength of 3000 psi.
 - 2. Protect existing piping to prevent concrete or debris from entering while making tap connections. Remove debris or other extraneous material that may accumulate.

3.9 IDENTIFICATION

- A. Refer to 31 2333 "Trenching and Backfill" for continuous underground warning tape installed over underground sanitary sewer piping.

3.10 FIELD QUALITY CONTROL

- A. Inspect interior of piping to determine whether line displacement or other damage has occurred. Inspect after approximately 24 inches of backfill is in place, and again at completion of Project.
 - 1. Submit separate report for each system inspection.

2. Defects requiring correction include the following:
 - (a) Alignment: Less than full diameter of inside of pipe is visible between structures.
 - (b) Deflection: Flexible piping with deflection that prevents passage of ball or cylinder of size not less than 92.5 percent of piping diameter.
 - (c) Crushed, broken, cracked, or otherwise damaged piping.
 - (d) Infiltration: Water leakage into piping.
 - (e) Exfiltration: Water leakage from or around piping.
3. Replace defective piping using new materials, and repeat inspections until defects are within allowances specified.
4. Re-inspect and repeat procedure until results are satisfactory.
- B. Test new piping systems, and parts of existing systems that have been altered, extended, or repaired, for leaks and defects.
 1. Do not enclose, cover, or put into service before inspection and approval.
 2. Test completed piping systems according to authorities having jurisdiction.
 3. Schedule tests and inspections by authorities having jurisdiction with at least one working day's advance notice.
 4. Submit separate report for each test.
- C. Leaks constitute defects that must be repaired.
- D. Replace leaking piping using new materials.

3.11 CLEANING

- A. Clean interior of piping of dirt and superfluous materials. Flush with potable water.
- B. Where connecting to existing sewer lines, clean existing line from point-of-connection to nearest downstream manhole or catch basin.

END OF SECTION 33 3100

SECTION 33 4000

SITE STORM DRAINAGE

PART 1 - GENERAL

1.1 RELATED DOCUMENTS

- A. Drawings and general provisions of the Contract, including General and Supplementary Conditions and Division 1 Specification Sections, apply to this Section.

1.2 SUMMARY

- A. This Section includes gravity-flow, non-pressure storm drain piping outside the building, and the following components:
 - 1. Drainage Inlets.
 - 2. Area Drains
 - 3. Cleanouts
 - 4. Subdrain Systems
 - 5. Bioretention Systems
- B. Related Sections include:
 - 1. Section 31 2333 "Trenching and Backfill" for trenching and backfilling for underground storm drain lines, and detectable warning tapes.

1.3 DEFINITIONS

- A. DN: Dimension Nominal.
- B. NPS: Nominal Pipe Size.
- C. PVC: Polyvinyl chloride plastic.
- D. HDPE: High-Density Polyethylene.
- E. SDR: Standard Dimension Ratio, derived by dividing the outside diameter of the pipe by the pipe wall thickness.

1.4 SUBMITTALS

- A. Product Data: For the following:
 - 1. Piping and related specialties.
 - 2. Drainage Inlets.
 - 3. Area Drains.
 - 4. Cleanouts.
 - 5. Subdrain Systems.
- B. Shop Drawings: For the following:
 - 1. Drains and Inlets: Include plans, elevations, sections, details, and frames, covers, and grates.
- C. Coordination Drawings: Show pipe sizes, locations, and elevations. Show other piping in the vicinity and clearances from storm drainage system piping. Indicate interface and spatial relationship between manholes, piping, and proximate structures.
- D. Field quality-control test reports.
- E. Record drawings of installed storm drainage lines and appurtenances in accordance Division 1 Section for project closeout requirements.
 - 1. Locate and dimension work with reference to permanent landmarks. Indicate materials and sizes of all components.

1.5 DELIVERY, STORAGE, AND HANDLING

- A. Deliver piping with factory-applied end caps. Maintain end caps through shipping, storage, and handling to prevent pipe-end damage and to prevent entrance of dirt, debris, and moisture.
- B. Protect pipe, pipe fittings, and seals from dirt and damage.
- C. Do not store plastic manholes, pipe, and fittings in direct sunlight.
- D. Handle catch basins and drainage inlets according to manufacturer's written rigging instructions.

1.6 PROJECT CONDITIONS

- A. Interruption of Existing Storm Drainage Service: Do not interrupt service to facilities occupied by Owner or others unless permitted under the following conditions and then only after arranging to provide temporary service according to requirements indicated:
 - 1. Notify Architect no fewer than five working days in advance of proposed interruption of service.

2. Do not proceed with interruption of service without Architect's written permission.
- B. Information shown regarding locations of existing utilities is based upon available records and data, but shall be regarded as approximate, only. Make minor deviations necessary to conform to actual locations and conditions without extra cost. Verify location and elevation of utilities prior to commencement of excavation.
 1. Exercise extreme care in excavating near existing utilities. Contractor is responsible for damage to existing utilities.

1.7 COORDINATION

- A. Coordinate connection in public right of way with City of Brentwood.
- B. Coordinate placement of structures with layout of pavement joints and patterns. Refer to Drawings for layout.
- C. Coordinate crossings with other underground utilities.
- D. Coordinate with locations of building down spouts.

PART 2 - PRODUCTS

2.1 PIPING MATERIALS

- A. HDPE Pipe and Fitting.
 1. HDPE shall be AASHTO designation M-294 and Caltrans Specifications Section 64.
- B. PVC Pipe and Fittings
 1. PVC Sewer Pipe and Fittings, NPS 15 (DN 375) and Smaller: ASTM D 3034, SDR 35, with bell-and-spigot ends for gasketed joints with ASTM F477, elastomeric seals. Couplings and joints shall meet the requirements in ASTM D3212.

2.2 DRAINAGE INLETS (DI)

- A. Precast reinforced concrete square drain box with galvanized steel frame for grate; galvanized welded steel bar grate with hold-down bolts.
 1. Products: Subject to compliance with requirements, provide one of the following:
 - (a) Central Precast Products: Refer to structure types and sizes specified on plans.
 - (b) Equal product in accordance with Division 1 requirements for product substitutions.
 2. Joint Sealants: ASTM C 990, bitumen or butyl rubber.

2.3 AREA DRAINS (AD)

- A. Refer to Area Drain detail shown on plans.
- B. Area Drains to be provided at locations shown on plans.
- C. Area Drain cover to be one of the following:
 - 1. NDS 6" Spee-D round basin with round brass grates.
 - 2. Equal product in accordance with Division 1 requirements for product substitutions.

2.4 CLEANOUTS (CO)

- A. Refer to Storm Drain Cleanout detail shown on plans.
- B. Storm drain cleanouts to be provided at all locations rainwater leaders have a change in direction, not including the connection to the main.
- C. Riser pipe to be 4" PVC with plug.

2.5 SUBDRAIN SYSTEMS

- A. Provide 6" ADS N-12 perforated drain pipe with smooth interior walls and holes down, per Subdrain detail shown on plans.
- B. Wrap pipe in filter fabric sock and connect to storm drain system.
- C. Pipe to be laid in small groove on class 2 permeable material per Caltrans Standard Specifications.

2.6 CONCRETE

- A. General: Cast-in-place concrete according to ACI 318, ACI 350R, and the following:
 - 1. Cement: ASTM C 150, Type II.
 - 2. Fine Aggregate: ASTM C 33, sand.
 - 3. Coarse Aggregate: ASTM C 33, crushed gravel.
 - 4. Water: Potable.
- B. Portland Cement Design Mix: 4000 psi minimum, with 0.45 maximum water-cementitious materials ratio.
- C. Reinforcement:
 - 1. Reinforcement Fabric: ASTM A 185, steel, welded wire fabric, plain.
 - 2. Reinforcement Bars: ASTM A 615, Grade 60, deformed steel.

PART 3 - EXECUTION

3.1 EARTHWORK

- A. Refer to Section 31 2000 "Earthwork" for excavation, trenching, and backfilling.

3.2 PREPARATION

- A. Where connecting to existing drain lines, verify existing line is free-draining prior to making connection. If required, clean existing line to achieve free-draining condition.

3.3 PIPING INSTALLATION

- A. General Locations and Arrangements: Drawing plans and details indicate general location and arrangement of underground storm drainage piping. Location and arrangement of piping layout take design considerations into account. Install piping as indicated, to extent practical. Where specific installation is not indicated, follow piping manufacturer's written instructions.
- B. Install piping at low point, true to grades and alignment indicated with unbroken continuity of invert. Place bell ends of piping facing upstream. Install gaskets, seals, sleeves, and couplings according to manufacturer's written instructions for use of lubricants, cements, and other installation requirements.
- C. Install piping free of sags and bends.
- D. Use fittings for changes in direction and branch connections unless indicated otherwise.
- E. Install proper size increasers, reducers, and couplings where different sizes or materials of pipes and fittings are connected. Reducing size of piping in direction of flow is prohibited.
- F. Tunneling: Install pipe under streets or other obstructions that cannot be disturbed by tunneling, jacking, or a combination of both.
- G. Install gravity-flow, non-pressure drainage piping according to the following:
 - 1. Install piping pitched down in direction of flow, at slope indicated, but in no case less than 0.3 percent.
 - 2. Install piping at elevations and inverts indicated, but in no case with less than 18-inch cover.
 - 3. Install PVC storm drain piping according to ASTM D 2321 and ASTM F 1668.
- H. Clear interior of piping of dirt and superfluous material as work progresses. Maintain swab or drag in piping, and pull past each joint as it is completed. Place plug in end of incomplete piping at end of day and when work stops.

3.4 PIPE JOINT CONSTRUCTION

- A. Join gravity-flow, non-pressure drainage piping according to the following:

1. Join PVC storm drainage piping according to ASTM D 2321 and ASTM D 3034 for elastomeric-seal joints or ASTM D 3034 for elastomeric gasket joints.
2. Join dissimilar pipe materials with pressure-type couplings.

3.5 DRAINAGE INLET AND CATCH BASIN INSTALLATION

- A. Install drainage inlets at locations indicated on plans.
- B. Set drain frames and covers with tops flush with pavement surface.
- C. Fasten grates to drains.

3.6 SUBDRAIN INSTALLATION

- A. Install subdrains at locations indicated.
- B. Assemble pipes to slope down toward drain outlets.
- C. Install perforated pipes with holes facing down.

3.7 CONCRETE PLACEMENT

- A. Place cast-in-place concrete according to ACI 318/318R.

3.8 CONNECTIONS

- A. Make connections to existing storm drainage piping.
 1. Use commercially manufactured wye fittings for piping branch connections. Remove section of existing pipe; install wye fitting into existing piping; and encase entire wye fitting, plus 6-inch overlap, with not less than 6-inches of concrete with 28-day compressive strength of 3000 psi.
 2. Protect existing piping to prevent concrete or debris from entering while making tap connections. Remove debris or other extraneous material that may accumulate.

3.9 IDENTIFICATION

- A. Refer to Section 31 2333 "Trenching and Backfill" for continuous underground warning tape installed over underground storm drainage piping.

3.10 FIELD QUALITY CONTROL

- A. Inspect interior of piping to determine whether line displacement or other damage has occurred. Inspect after approximately 24 inches of backfill is in place, and again at completion of Project.
 1. Submit separate reports for each system inspection.
 2. Defects requiring correction include the following:

- (a) Alignment: Less than full diameter of inside of pipe is visible between structures.
 - (b) Deflection: Flexible piping with deflection that prevents passage of ball or cylinder of size not less than 92.5 percent of piping diameter.
 - (c) Crushed, broken, cracked, or otherwise damaged piping.
 - (d) Infiltration: Water leakage into piping.
 - (e) Exfiltration: Water leakage from or around piping.
3. Replace defective piping using new materials, and repeat inspections until defects are within allowances specified.
4. Re-inspect and repeat procedure until results are satisfactory.
- B. Test new piping systems, and parts of existing systems that have been altered, extended, or repaired, for leaks and defects.
 1. Do not enclose, cover, or put into service before inspection and approval.
 2. Test completed piping systems according to authorities having jurisdiction.
 3. Schedule tests and inspections by authorities having jurisdiction with at least two working days advance notice.
 4. Submit separate report for each test.
- C. Leaks constitute defects that must be repaired.
- D. Replace leaking piping using new materials.

3.11 CLEANING

- A. Clean interior of piping of dirt and superfluous materials. Flush with potable water.
- B. Where connecting to existing drain lines, clean existing line from point-of-connection to nearest downstream manhole or catch basin.

END OF SECTION 33 4000